

**MSY-GS09NA & MUY-GS09NA**  
**9,000 BTU/H WALL-MOUNTED INDOOR UNIT**  
**9,000 BTU/H COOLING ONLY OUTDOOR UNIT**



Job Name:

System Reference:

Date:



Indoor Unit.....MSY-GS09NA

Outdoor Unit.....MUY-GS09NA

**INDOOR UNIT FEATURES**

- Slim wall-mounted indoor units provide zone comfort control
- Dual Barrier Coating applied to the heat exchanger, vanes and fan to prevent hydrophilic and hydrophobic dirt build-up
- Optional Microparticle Filter designed to capture PM2.5
- The outdoor unit powers the indoor unit, and should a power outage occur, the system is automatically restarted when power returns
- Quiet operation
- Smart Set: recalls a preferred preset temperature setting at the touch of a button
- Multiple fan speed options: Quiet, Low, Medium, High, Super-high, Auto
- Multiple control options available:
  - Back-lit screen handheld remote controller (provided with the unit)
  - kumo cloud® smart device app for remote access
  - Third-party interface options
  - Wired or wireless controllers

**OUTDOOR UNIT FEATURES**

- INVERTER-driven compressor and LEV provide high efficiency and comfort while using only the energy needed to maintain maximum performance
- Blue Fin anti-corrosion treatment applied to the outdoor unit heat exchanger for increased coil protection and longer life
  - Rated for 2,000 hours spraying time per ASTM B117 Standard

# SPECIFICATIONS: MSY-GS09NA & MUY-GS09NA

Cooling at 95°F <sup>1</sup>	Maximum Capacity	BTU/H	12,200
	Rated Capacity	BTU/H	9,000
	Minimum Capacity	BTU/H	3,600
	Maximum Power Input	W	1,050
	Rated Power Input	W	585
	Moisture Removal	Pints/h	0.8
	Sensible Heat Factor		0.90
Efficiency	Power Factor [208V / 230V]	%	90.0 / 90.0
	SEER   SEER2		27.0   28.4
	EER <sup>1</sup>   EER2 <sup>1</sup>		15.4   15.4
Electrical	ENERGY STAR® Certified		Yes
	Voltage, Phase, Frequency		208/230, 1, 60
	Guaranteed Voltage Range	V AC	187 - 253
	Voltage: Indoor - Outdoor, S1-S2	V AC	208/230
	Voltage: Indoor - Outdoor, S2-S3	V DC	24
	Short-circuit Current Rating [SCCR]	kA	5
	Recommended Fuse/Breaker Size (Outdoor)	A	15
	Recommended Wire Size [Indoor - Outdoor]	AWG	14
	Power Supply		Indoor unit is powered by the outdoor unit
	Indoor Unit	MCA	A
Fan Motor Full Load Amperage		A	0.5
Fan Motor Output		W	30
Airflow Rate at Cooling, Dry		CFM	134–160–222–307–381
Airflow Rate at Cooling, Wet		CFM	121–144–200–276–343
Sound Pressure Level [Cooling]		dB[A]	19–22–30–37–43
Drain Pipe Size		In. [mm]	5/8 [15.88]
Coating on Heat Exchanger			Dual Barrier Coating
External Finish Color			Munsell 1.0Y 9.2/0.2
Unit Dimensions		W x D x H: In. [mm]	31-7/16 x 9-1/8 x 11-5/8 [798 x 232 x 295]
Package Dimensions		W x D x H: In. [mm]	33-1/2 x 12 x 14 [850 x 300 x 350]
Unit Weight		Lbs. [kg]	23 [10.4]
Package Weight		Lbs. [kg]	26 [11.5]
Indoor Unit Operating Temperature Range	Cooling Intake Air Temp [Maximum / Minimum]*	°F	90 DB, 73 WB / 67 DB, 57 WB
Outdoor Unit	MCA	A	10.0
	MOCP	A	15
	Fan Motor Full Load Amperage	A	0.5
	Fan Motor Output	W	55
	Refrigerant Control		Linear expansion valve
	Defrost Method		N/A
	Sound Pressure Level, Cooling <sup>1</sup>	dB(A)	48
	Compressor Type		DC inverter driven Twin Rotary
	Compressor Model		SNB092FQAMT
	Compressor Rated Load Amps	A	6.72
	Compressor Locked Rotor Amps	A	8.4
	Compressor Oil [Type // Charge]	oz.	FV50S //9.1
	External Finish Color		Munsell 3Y 7.8/1/1
	Base Pan Heater		N/A
	Unit Dimensions	W x D x H: In. [mm]	31-1/2 x 11-1/4 x 21-5/8 [800 x 285 x 550]
Package Dimensions	W x D x H: In. [mm]	37 x 15 x 24-1/2 [980 x 380 x 630]	
Unit Weight	Lbs. [kg]	79 [35.8]	
Package Weight	Lbs. [kg]	87 [39.2]	
Outdoor Unit Operating Temperature Range	Cooling Air Temp [Maximum / Minimum]*	°F	115 DB / 14 DB
	Cooling Thermal Lock-out / Re-start Temperatures**	°F	-4 / 0
Refrigerant	Type		R410A
	Pre-Charged Refrigerant Amount	Lbs, oz	0.4, 11.8
	Maximum Pre-Charged Piping Length	Ft. [m]	25.0 [7.5]
	Additional Refrigerant Charge Per Additional Piping Length	oz./Ft. [g/m]	1.08 [20]
Piping	Gas Pipe Size O.D. [Flared]	In.[mm]	3/8 [9.52]
	Liquid Pipe Size O.D. [Flared]	In.[mm]	1/4 [6.35]
	Maximum Piping Length	Ft. [m]	65 [20]
	Maximum Height Difference	Ft. [m]	40 [12]
	Maximum Number of Bends		10

**NOTES:**

AHRI Rated Conditions

(Rated data is determined at a fixed compressor speed)

<sup>1</sup>Cooling (Indoor // Outdoor)

<sup>2</sup>Heating at 47°F (Indoor // Outdoor)

<sup>3</sup>Heating at 17°F (Indoor // Outdoor)

°F 80 DB, 67 WB // 95 DB, 75 WB

°F 70 DB, 60 WB // 47 DB, 43 WB

°F 70 DB, 60 WB // 17 DB, 15 WB

\*Indoor/Outdoor Unit Operating Temperature Range (Cooling Air Temp [Maximum / Minimum]):

• Applications should be restricted to comfort cooling only; equipment cooling applications are not recommended for low ambient temperature conditions.

\*\*Outdoor Unit Operating Temperature Range (Cooling Thermal Lock-out / Re-start Temperatures):

• System cuts out in heating mode to avoid thermistor error and automatically restarts at these temperatures.

## INDOOR UNIT ACCESSORIES: MSY-GS09NA

Control Interface	BACnet® and Modbus® Interface	PAC-UKPRC001-CN-1
	IT Extender	PAC-WHS01IE-E
	kumo station® for kumo cloud®	PAC-WHS01HC-E
	System Control Interface	MAC-334IF-E
	Thermostat Interface	PAC-US444CN-1
	Thermostat Interface	PAC-US445CN-1
	USNAP Adapter	PAC-WHS01UP-E
	Wireless Interface for kumo cloud®	PAC-USWHS002-WF-2
Remote Sensor	Wired Remote Sensor	M21EAA307
	Wireless temperature and humidity sensor for kumo cloud®	PAC-USWHS003-TH-1
Wired Remote Controller	Deluxe Wired MA Remote Controller†	PAR-40MAAU
	Simple Ductless Wired Remote Controller	PAC-SDW01RC-1
	Simple MA Remote Controller†	PAC-YT53CRAU-J
	Touch MA Controller†	PAR-CT01MAU-SB
Wireless Remote Controller	kumo touch™ RedLINK™ Wireless Controller	MHK2
	Lockdown bracket for remote controller	RCMKP1CB
Condensate	Blue Diamond (Advanced) Mini Condensate Pump w/ Reservoir & Sensor (208/230V) [recommended]	X87-721
	Blue Diamond (MegaBlue Advanced) Condensate Pump w/ Reservoir & Sensor	X87-835
	Blue Diamond Alarm Extension Cable — 6.5 Ft.	C13-192
	Blue Diamond MultiTank — collection tank for use with multiple pumps	C21-014
	Blue Diamond Sensor Extension Cable — 15 Ft.	C13-103
	Drain Pan Level Sensor/Control	SS610E
	Fascia Kit for MicroBlue Pump, mounts the MicroBlue and sensor directly beneath indoor unit	T18-016
	Refco Condensate Pump (100-240 VAC)	GOBI-II
	Refco Condensate Pump (100-240 VAC) up to 120,000 BTU/H	COMBI
Disconnect Switch	(30A/600V/UL) [fits 2" X 4" utility box] - Black	TAZ-MS303
	(30A/600V/UL) [fits 2" X 4" utility box] - White	TAZ-MS303W
Filter	Anti-allergy Enzyme Filter	MAC-408FT-E
	Microparticle (PM2.5) Filter	MAC-EMF515FT-E

**NOTES:**

†Requires MAC-334IF-E

- M-Series EZ FIT® Recessed Ceiling Cassette, Floor-mount and Wall-mount  
Allows indoor units to connect to an MA Controller:
  - Deluxe MA Remote Controller
  - Simple MA Controller
  - Touch MA Controller

## OUTDOOR UNIT ACCESSORIES: MUY-GS09NA

Hail Guards	Hail Guard	HG-B4
Lineset	15' x 1/4" x 15' / 3/8" Lineset (Twin-Tube Insulation)	MLS143812T-15
	30' x 1/4" x 30' / 3/8" Lineset (Twin-Tube Insulation)	MLS143812T-30
	50' x 1/4" x 50' / 3/8" Lineset (Twin-Tube Insulation)	MLS143812T-50
	65' x 1/4" x 65' / 3/8" Lineset (Twin-Tube Insulation)	MLS143812T-65
Mounting Pad	Condensing Unit Mounting Pad: 16" x 36" x 3"	ULTRILITE1
	Outdoor Unit 3-1/4 inch Mounting Base (Pair) - Plastic	DSD-400P
Stand	18" Single Fan Stand	QSMS1801M
	24" Single Fan Stand	QSMS2401M
	Condenser Wall Bracket	QSWB2000M-1
	Condenser Wall Bracket - Stainless Steel Finish	QSWBSS
	Outdoor Unit Stand — 12" High	QSMS1201M

# INDOOR UNIT DIMENSIONS: MSY-GS09NA

Unit: inch

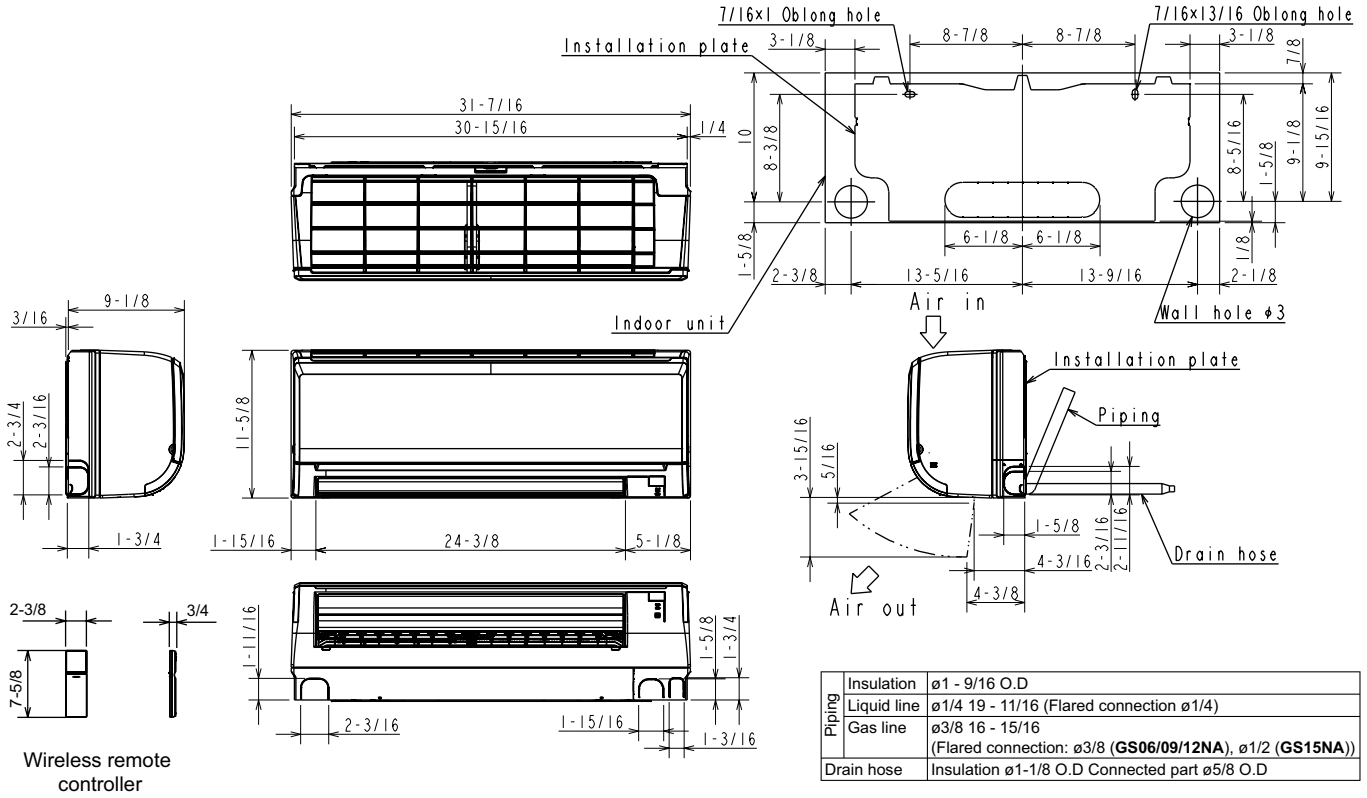

# OUTDOOR UNIT DIMENSIONS: MUY-GS09NA

Unit: inch

## REQUIRED SPACE

\*1 4 in. or more when front and sides of the unit are clear

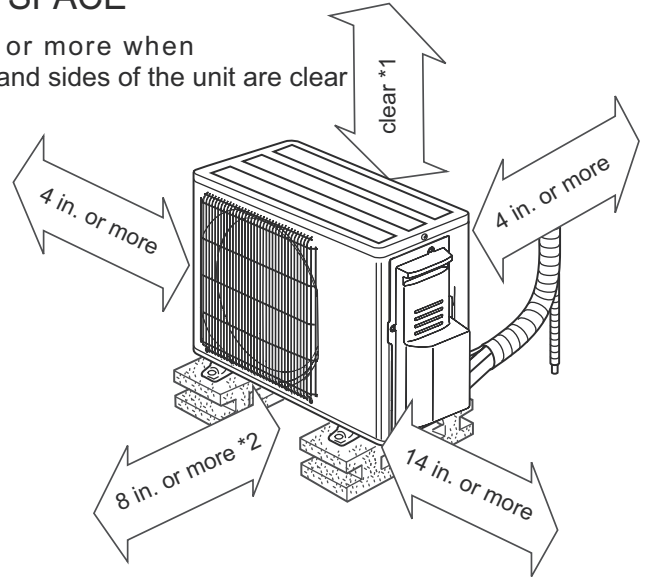

\*2 When any 2 sides of left, right and rear of the unit are clear

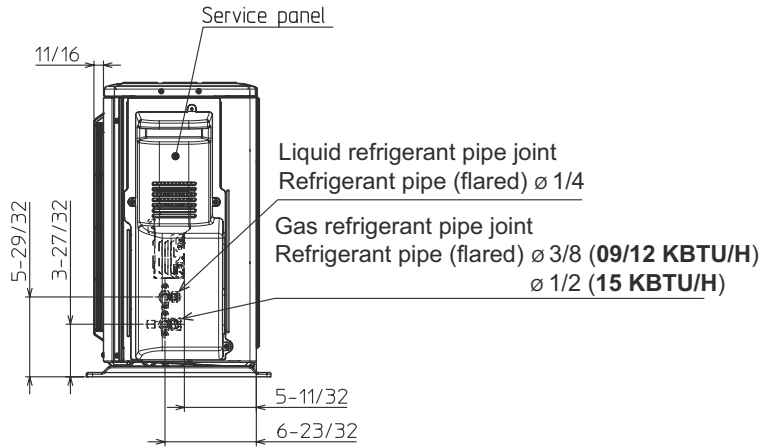
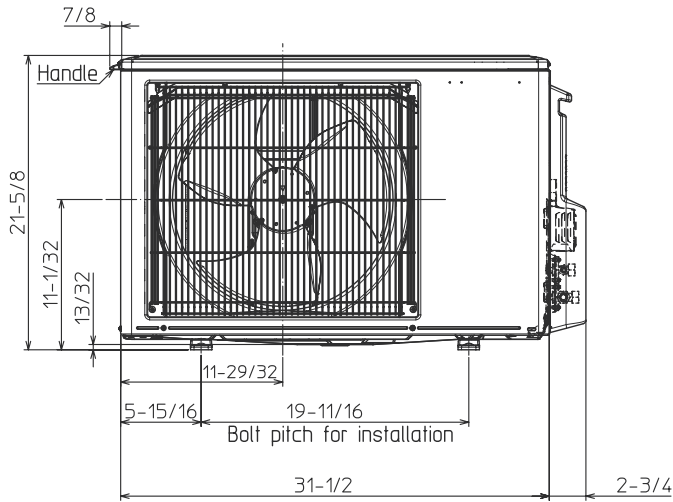
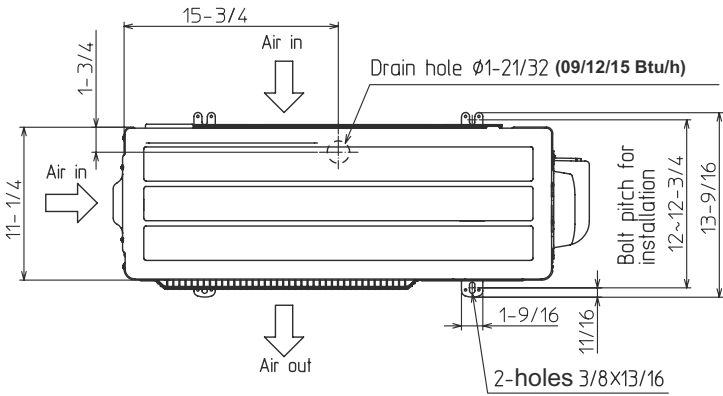

1340 Satellite Boulevard Suwanee, GA 30024  
Toll Free: 800-433-4822 www.mehvac.com

FORM# MSY-GS09NA & MUY-GS09NA - 202304

