



SHADOW

**High Efficiency Gas-Fired Hot Water
Direct Vent Condensing Boilers**

INSTALLATION AND OPERATING INSTRUCTIONS

These instructions must be affixed on or adjacent to the boiler and retained for future reference.



As an ENERGY STAR® Partner, Velocity Boiler Works has determined that the SHADOW Series meets the ENERGY STAR® guidelines for energy efficiency established by the United States Environmental Protection Agency (EPA).



WARNING

Improper installation, adjustment, alteration, service or maintenance can cause property damage, injury, or loss of life. For assistance or additional information, consult a qualified installer, service agency or the gas supplier. This boiler requires a special venting system. Read these instructions carefully before installing.



**Quality
Value &
Service**

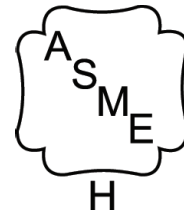

**Velocity Boiler Works, LLC
P.O. Box 14818
3633 I Street
Philadelphia, PA 19134**

IMPORTANT INFORMATION - READ CAREFULLY

The following terms are used throughout this manual to bring attention to the presence of hazards of various risk levels, or to important information concerning product life.



DANGER

Indicates an imminently hazardous situation which, if not avoided, will result in death, serious injury or substantial property damage.



CAUTION

Indicates a potentially hazardous situation which, if not avoided, may result in moderate or minor injury or property damage.



WARNING

Indicates a potentially hazardous situation which, if not avoided, could result in death, serious injury or substantial property damage.

NOTICE

Indicates special instructions on installation, operation, or maintenance which are important but not related to personal injury hazards.



WARNINGS FOR THE HOMEOWNER

FOLLOW ALL INSTRUCTIONS and warnings printed in this manual, the owner's manual and posted on the boiler.

MAINTAIN THE BOILER. To keep your boiler safe and efficient, have a service technician maintain this boiler as specified in Part XIII of the manual.

IF YOU ARE NOT QUALIFIED to install or service boilers, do not install or service this one.

THE BOILER MAY LEAK WATER at the end of its useful life. Be sure to protect walls, carpets, and valuables from water that could leak from the boiler.

PROTECT YOUR HOME IN FREEZING WEATHER. A power outage, safety lockout, or component failure will prevent your boiler from lighting. In winter, your pipes may freeze and cause extensive property damage. Do not leave the heating system unattended during cold weather unless alarms or other safeguards are in place to prevent such damage.

DO NOT BLOCK AIR FLOW into or around the boiler. Insufficient air may cause the boiler to produce carbon monoxide or start a fire.

KEEP FLAMMABLE LIQUIDS AWAY from the boiler, including paint, solvents, and gasoline. The boiler may ignite the vapors from the liquids causing explosion or fire.

KEEP CHILDREN AND PETS away from hot surfaces of the boiler, boiler piping, vent piping and vent terminals.

CARBON MONOXIDE (CO) is an odorless, deadly gas that may be introduced into your home by any malfunctioning fuel-burning product or vent system failure. Consider installing CO alarms near bedrooms in all levels of the building to warn you and your family of potential CO exposure.



DANGER

Explosion Hazard. DO NOT store or use gasoline or other flammable vapors or liquids in the vicinity of this or any other appliance.

If you smell gas vapors, DO NOT try to operate any appliance - DO NOT touch any electrical switch or use any phone in the building. Immediately, call the gas supplier from a remotely located phone. Follow the gas supplier's instructions or if the supplier is unavailable, contact the fire department.



WARNING

- **Asphyxiation Hazard. This boiler requires regular maintenance and service to operate safely. Follow the instructions contained in this manual.**
- **Improper installation, adjustment, alteration, service or maintenance can cause property damage, personal injury or loss of life. Read and understand the entire manual before attempting installation, start-up operation, or service. Installation and service must be performed only by an experienced, skilled, and knowledgeable installer or service agency.**
- **This boiler must be properly vented.**
- **This boiler needs fresh air for safe operation and must be installed so there are provisions for adequate combustion and ventilation air.**
- **Asphyxiation Hazard. The interior of the venting system must be inspected and cleaned before the start of the heating season and should be inspected periodically throughout the heating season for any obstructions. A clean and unobstructed venting system is necessary to allow noxious fumes that could cause injury or loss of life to vent safely and will contribute toward maintaining the boiler's efficiency.**
- **Installation is not complete unless a safety relief valve is installed into the supply piping immediately downstream of the boiler. - See the Water Piping and Trim Section of this manual for details.**
- **This boiler is supplied with safety devices which may cause the boiler to shut down and not re-start without service. If damage due to frozen pipes is a possibility, the heating system should not be left unattended in cold weather; or appropriate safeguards and alarms should be installed on the heating system to prevent damage if the boiler is inoperative.**
- **Burn Hazard. This boiler contains very hot water under high pressure. Do not unscrew any pipe fittings nor attempt to disconnect any components of this boiler without positively assuring the water is cool and has no pressure. Always wear protective clothing and equipment when installing, starting up or servicing this boiler to prevent scald injuries. Do not rely on the pressure and temperature gauges to determine the temperature and pressure of the boiler. This boiler contains components which become very hot when the boiler is operating. Do not touch any components unless they are cool.**
- **Respiratory Hazard. Boiler materials of construction, products of combustion and the fuel contain alumina, silica, heavy metals, carbon monoxide, nitrogen oxides, aldehydes and/or other toxic or harmful substances which can cause death or serious injury and which are known to the state of California to cause cancer, birth defects and other reproductive harm. Always use proper safety clothing, respirators and equipment when servicing or working nearby the appliance.**
- **Failure to follow all instructions in the proper order can cause personal injury or death. Read all instructions, including all those contained in component manufacturers manuals which are provided with the boiler before installing, starting up, operating, maintaining or servicing.**
- **All cover plates, enclosures and guards must be in place at all times.**

Table of Contents

I.	Product Description	4
II.	Specifications	4
III.	Before Installing	5
IV.	Locating The Boiler	6
V.	Mounting The Boiler	7
VI.	Air For Ventilation	8
VII.	Venting	11
	A. General Vent System Design	11
	B. Design Requirements Unique to Horizontal Twin Pipe Venting Systems	17
	C. Design Requirements Unique to Vertical Venting Systems	22
	D. Design Requirements Unique to Split Vent Systems	25
	E. Assembly of CPVC/PVC Vent Systems	27
	F. Condensate Trap and Drain	34
	G. Removing An Existing Boiler From Common Chimney	35
VIII.	Gas Piping	36
IX.	System Piping	38
	A. General System Piping Precaution	38
	B. Near Boiler Piping Design	39
	C. Standard Piping Installation Requirements	44
	D. Piping For Special Situations	45
X.	Wiring	47
XI.	Start-up and Checkout	55
XII.	Operation	62
XIII.	Service and Maintenance	69
XIV.	Troubleshooting	75
XV.	Parts	83
	Appendix A: LP Gas Conversion Instructions	93
	Appendix B: Special Requirements For Side-Wall Vented Appliances In The Commonwealth of Massachusetts	97
	Appendix C: Control Set-up Using PIM	99

I Product Description

This boiler is a stainless steel gas fired condensing boiler designed for use in forced hot water heating systems requiring supply water temperatures of 180°F or less. It is designed for installation on a wall. This boiler may be vented vertically or horizontally with combustion air supplied from outdoors. It is not designed for use in systems containing significant amounts of dissolved oxygen.

II Specifications

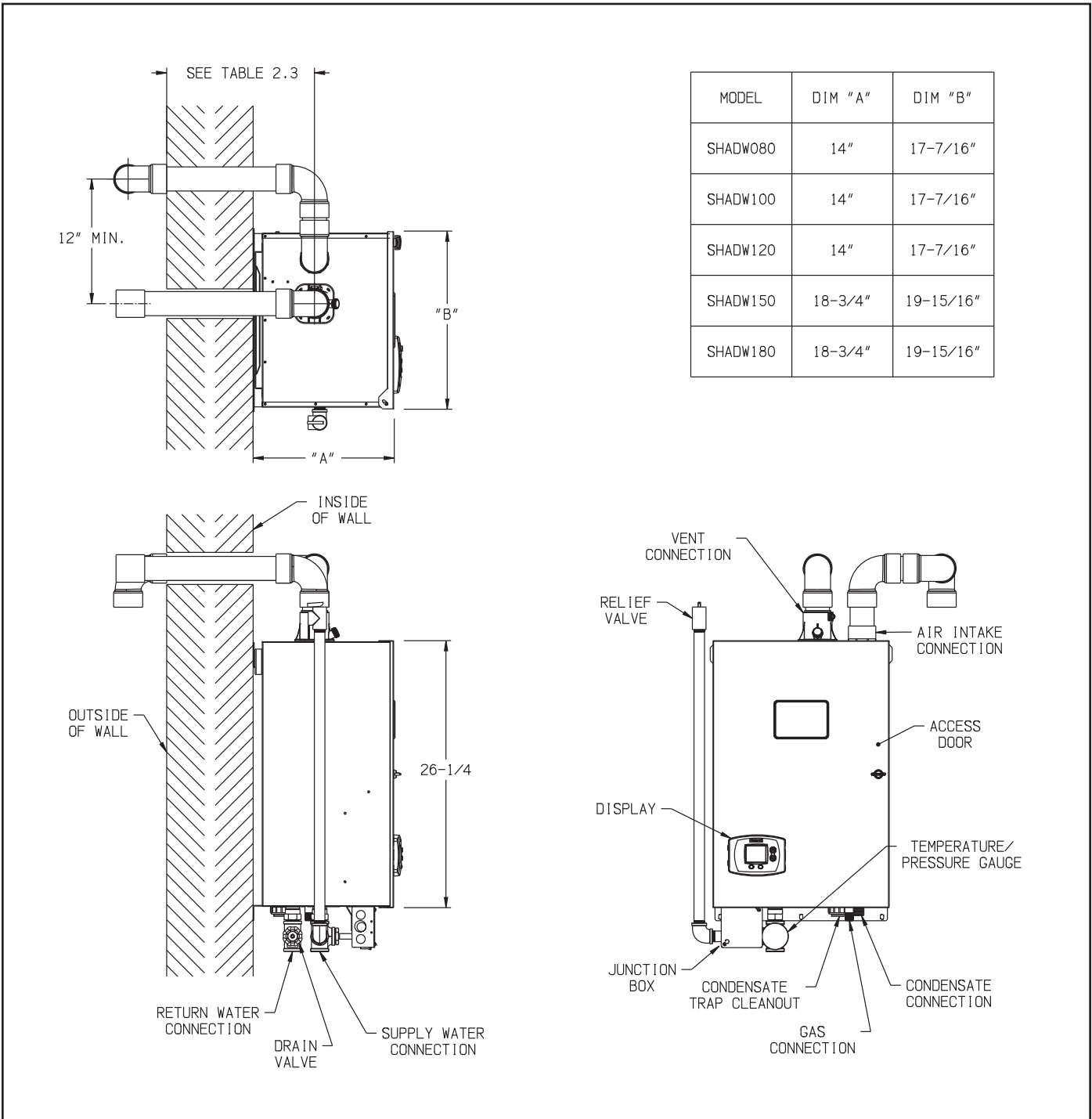



FIGURE 2.1: GENERAL CONFIGURATION

Table 2.2: Specifications

 SHADOW Series AHRI Ratings						Other Specifications				
MODEL*	MAXIMUM INPUT (MBH)	MINIMUM INPUT (MBH)	HEATING CAPACITY (MBH)	NET AHRI RATING* (MBH)	AFUE (%)	WATER VOLUME (Gal.)	VENT COLLAR DIA.	SUPPLY & RETURN CONNECTION SIZE (NPT)	GAS CONNECTION SIZE (NPT)	APPROX. NET WEIGHT (lb)
SHADW080	80	16	74	64	94.0	0.36	2"	1"	1/2"	81
SHADW100	100	20	92	80	93.3	0.44	2"	1"	1/2"	83
SHADW120	120	24	112	97	94.0	0.53	3"	1"	1/2"	86
SHADW150	150	30	142	123	95.0	0.79	3"	1"	1/2"	111
SHADW180	180	36	170	148	94.0	0.79	3"	1"	1/2"	111

* The Net AHRI Water Ratings shown are based on a piping and pickup allowance of 1.15. The manufacturer should be consulted before selecting a boiler for installations having unusual piping and pickup requirements, such as intermittent system operation, extensive piping systems, etc.

Table 2.3: Vent Lengths

MODEL	NOMINAL VENT/INTAKE SIZE (in)	MIN VENT LENGTH (in)	MAX VENT LENGTH	APPROX. DERATE AT MAX VENT (%)
SHADW080	2	12	60ft	9
SHADW080*	3	12	135ft	2
SHADW100	2	12	60ft	15
SHADW100*	3	12	135ft	3
SHADW120	3	12	135ft	7
SHADW150	3	52	135ft	7
SHADW180	3	52	135ft	9

See Part VII (Venting) for additional requirements and details.

*Vent/Intake size increased from 2" to 3" at boiler connections.

III Before Installing

- 1) Safe, reliable operation of this boiler depends upon installation by a professional heating contractor in strict accordance with this manual and the requirements of the authority having jurisdiction.
 - In the absence of an authority having jurisdiction, installation must be in accordance with this manual and the National Fuel Gas Code, ANSI Z223.1. In Canada, installation must be in accordance with the B149.1 Installation Code.
 - Where required by the authority having jurisdiction, this installation must conform to the *Standard for Controls and Safety Devices for Automatically Fired Boilers* (ANSI/ASME CSD-1).
- 2) Read Section VII to verify that the maximum combustion air and exhaust pipe lengths will not be exceeded in the planned installation. Also verify that the vent terminal can be located in accordance with Section VII.
- 3) Make sure that the boiler is correctly sized:
 - For heating systems employing convection radiation (baseboard or radiators), use an industry accepted sizing method such as the *I=B=R* Guide RHH published by the Air-Conditioning, Heating and Refrigeration Institute (AHRI).
 - For new radiant heating systems, refer to the radiant tubing manufacturer's boiler sizing guidelines.
 - For systems which include an indirect water heater, make sure the boiler has the output called for by the indirect water heater manufacturer's instructions.

- 4) All boilers are shipped from the factory configured for use with natural gas. They may be converted for use with LP gas (“propane”) using a combustion analyzer in accordance with the instructions in Appendix A.



DANGER

- **Do not attempt to operate this boiler on LP gas without converting it in accordance with the instructions shown in Appendix A.**
- **Do not attempt to convert this boiler to LP gas without the use of a combustion analyzer.**
- **Failure to follow the conversion instructions in Appendix A will result in operation of the boiler at unsafe Carbon Monoxide (CO) levels and may result in personal injury or loss of life. Improper conversion may also result in unreliable operation, resulting in property damage.**

- 5) Models are not suitable for installation at altitudes above 2000ft.



WARNING

Do not install this boiler at altitudes above 2000ft. Attempting to do so may result in unreliable operation, property damage, personal injury or loss of life.

NOTICE

This product must be installed by a licensed plumber or gas fitter when installed within the Commonwealth of Massachusetts. See Appendix B for additional important information about installing this product within the Commonwealth of Massachusetts.

IV Locating the Boiler

- 1) Observe the minimum clearances shown in Figure 4.1. These clearances apply to combustible construction as well as non-combustible walls, floors, ceilings and doors.
- 2) Note the recommended service clearances in Figure 4.1. These service clearances are recommended, but may be reduced to the combustible clearances provided:
 - a. Access to the front of the boiler is provided through a door.
 - b. Access is provided to the condensate trap located beneath the boiler.

Note that servicing the boiler will become increasingly difficult as these service clearances are reduced.

- 3) Observe the following clearances from piping to combustible construction:

Non-concentric vent (exhaust): ¼”

Air intake piping: 0”

Hot water piping: ¼”

- 4) The relief valve and gauge must be installed in the location shown in Figure 2.1 and must be in the same space as the boiler.
- 5) The boiler should be located so as to minimize the length of the vent system.
- 6) The combustion air piping must terminate where outdoor air is available for combustion and away from areas that will contaminate combustion air. Avoid areas near chemical products containing chlorine, chloride based salts, chloro/fluorocarbons, paint removers, cleaning solvents and detergents.

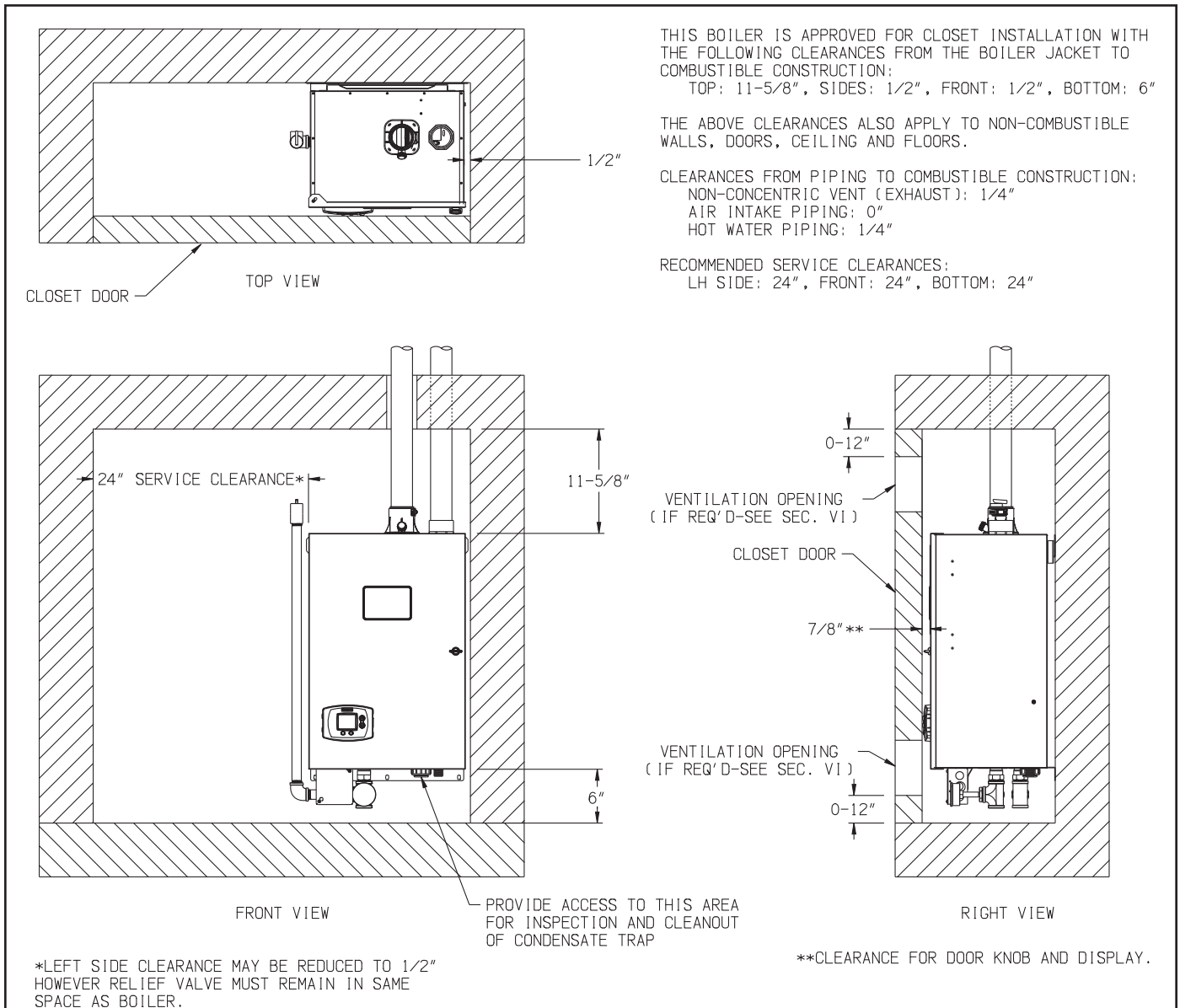

Figure 4.1: Minimum Clearances To Combustible Construction

V Mounting The Boiler



CAUTION

This boiler weighs as much as 111 pounds:

- Two people are required to safely lift this boiler onto the wall mounting hook.
- Make sure that wall mounting hook is anchored to a structure capable of supporting the weight of the boiler and attached piping when filled with water. Jurisdictions in areas subject to earthquakes may have special requirements for supporting this boiler. These local requirements take precedence over the requirements shown in this section.

- 1) If the boiler is installed on a framed wall, minimum acceptable framing is 2 x 4 studs on 16" centers. The boiler mounting holes are on 16" centers for installation between two studs at the standard spacing. In cases where the boiler cannot be centered between the studs, or where the studs are spaced closer than 16" apart, the boiler may be anchored to 3/4" plywood or horizontal 2 x 4s anchored to the studs.
- 2) 5/16" x 2" lag screws and washers are provided for mounting this boiler. These lag screws are intended for mounting the boiler directly onto studs covered with 1/2" sheathing. When the boiler is attached to other types of construction, such as masonry, use fasteners capable of supporting the weight of the boiler and attached piping in accordance with good construction practice and applicable local codes.
- 3) Make sure that the surface to which the boiler is mounted is plumb.
- 4) Before mounting the boiler, make sure that wall selected does not have any framing or other construction that will interfere with the vent pipe penetration.
- 5) Once a suitable location has been selected for the boiler, and any needed modifications have been made to the wall, use Figure 5.1 to locate holes "A" and "B". Make sure that the horizontal centerline of these holes is level. Holes "C" and "D" may also be drilled at this time or after the boiler is hung on the wall. If the 5/16" x 2" lag screws are used, drill 3/16" pilot holes.
- 6) The wall mounting hook is used to secure the boiler to the shipping pallet. Remove this hook from the pallet and secure to the wall using the 5/16" x 2" lag screws and washers, or other suitable anchors as appropriate (Figure 5.2). Make sure the hook is level.
- 7) Hang the boiler on the wall hook as shown in Figure 5.2.
- 8) If not already done in Step (5) locate and drill holes "C" and "D" using the obround slots in the bottom mounting flange. Secure the bottom flange to the wall using the 5/16"x 2" lag screws, or other fasteners as appropriate (Figure 5.2).
- 9) Verify that the front of the boiler is plumb. If it is not, install washers at holes "C" and "D" between the bottom mounting flange and the wall to adjust.

VI Air for Ventilation



WARNING

Outdoor combustion air must be piped to the air intake. Never pipe combustion air from areas containing contaminants such as swimming pools and laundry room exhaust vents. Contaminated combustion air will damage the boiler and may cause property damage, personal injury or loss of life.

Air for combustion must always be obtained directly from outdoors (see Section VII for intake piping). Although combustion air must always be obtained directly from outdoors, ventilation openings may still be required to prevent overheating of boiler components if the boiler is installed in a small space, such as a closet.

- If the recommended service clearances shown in Figure 4.1 can be maintained (with all doors to the room closed), no ventilation openings are required for this boiler.
- If the above service clearances cannot be maintained, provide two openings into the room, one near the floor and one near the ceiling. The top edge of the upper opening must be within 12" of the ceiling and the bottom edge of the lower opening within 12" of the floor. Each of these openings must have a free area of at least 100 square inches. The "free area" takes into account the blocking effect of mesh grilles and louvers. Where screens are used they must be no finer than 1/4" (4 x 4) mesh.
- If this boiler is installed in a room with other appliances, provide adequate air for combustion and/or ventilation in accordance with the other appliance manufacturer's installation manual or applicable code. In cases where such provisions require two openings in excess of 100 square inches, no additional opening area is required for this boiler.

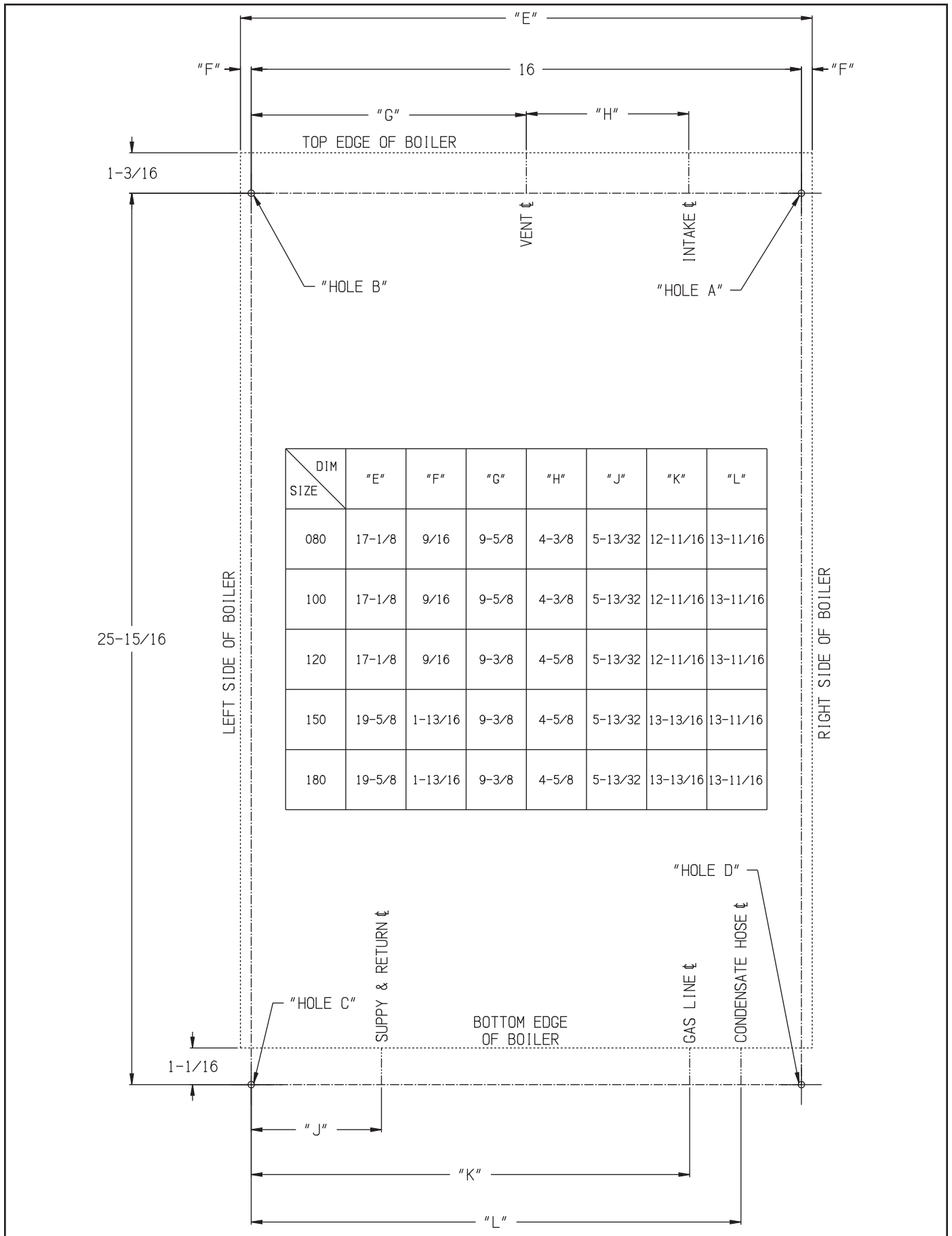

Figure 5.1 Wall Layout/Mounting Hole Location

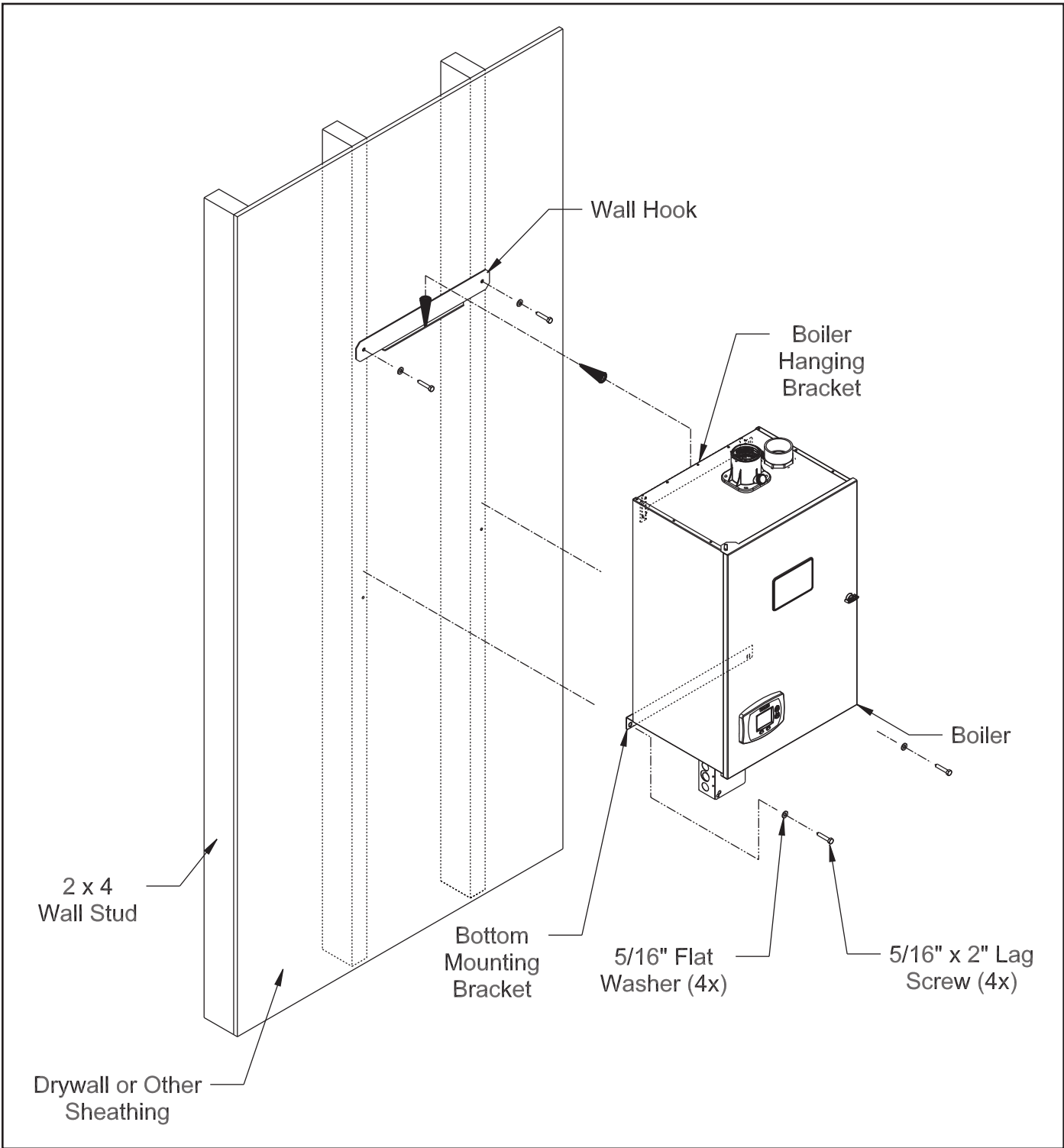

Figure 5.2 Boiler Mounting Bracket Installation / Boiler Wall Mounting

VII Venting



WARNING

- **Asphyxiation Hazard.** Failure to vent this boiler in accordance with these instructions could cause products of combustion to enter the building resulting in severe property damage, personal injury or death.
- Do not interchange vent systems or materials unless otherwise specified.
- The use of thermal insulation covering vent pipe and fittings is prohibited.
- Do not use a barometric damper, draft hood or vent damper with this boiler.
- When using the CPVC/PVC vent option, the use of CPVC is required when venting in vertical or horizontal chase ways.
- Any CPVC vent materials supplied with this boiler do not comply with B149.1.S1-07 and are not approved for use in Canadian jurisdictions that require vent systems be listed to ULC S636-2008. In these jurisdictions, vent this boiler using a listed ULC S636 Class IIB venting system.
- Do not locate vent termination where exposed to prevailing winds. Moisture and ice may form on surface around vent termination. To prevent deterioration, surface must be in good repair (sealed, painted, etc.).
- Do not locate air intake termination where chlorines, chlorofluorocarbons (CFC's), petroleum distillates, detergents, volatile vapors or other chemicals are present. Severe boiler corrosion and failure will result.
- The use of cellular core PVC (ASTM F891), cellular core CPVC or Radel (polyphenolsulfone) is prohibited.
- Do not locate vent termination under a deck.
- Do not reduce specified diameters of vent and combustion air piping.
- Do not allow low spots in the vent where condensate may pool.

NOTICE

This manual covers installation of vent options employing CPVC/PVC vent systems only. Other vent options exist for this boiler which use listed polypropylene (PP) vent systems offered by several manufacturers. Supplemental instructions for the design and installation of these vent systems with this boiler are available on our web site.

A. General Vent System Design

There are three basic ways to vent this boiler:

- **Horizontal (“Side Wall”) Twin Pipe Venting (Figure 7.0a)** - Vent system exits the building through an outside wall. Combustion air and flue gas are routed between the boiler and the terminal(s) using separate pipes. A summary of Horizontal Twin Pipe venting options is shown in Table 7.5.
- **Vertical Twin Pipe Venting (Figure 7.0b)** - Vent system exits the building through a roof. Combustion air and flue gas are routed between the boiler and the terminal(s) using separate pipes. A summary of Vertical Twin Pipe venting options is shown in Table 7.11
- **Split Venting (Figure 7.0c)** - Exhaust system exits the building through a roof, and combustion air is drawn from a terminal mounted on the side wall. A summary of split venting options is shown in Table 7.15

FIGURE 7.0 BASIC VENT OPTIONS

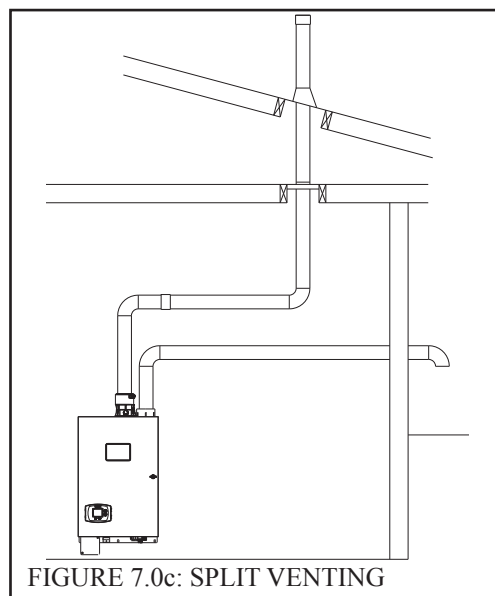
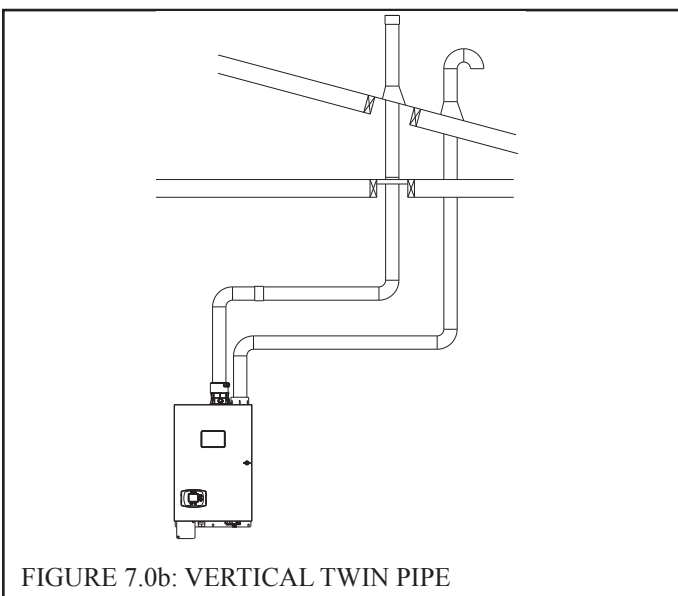
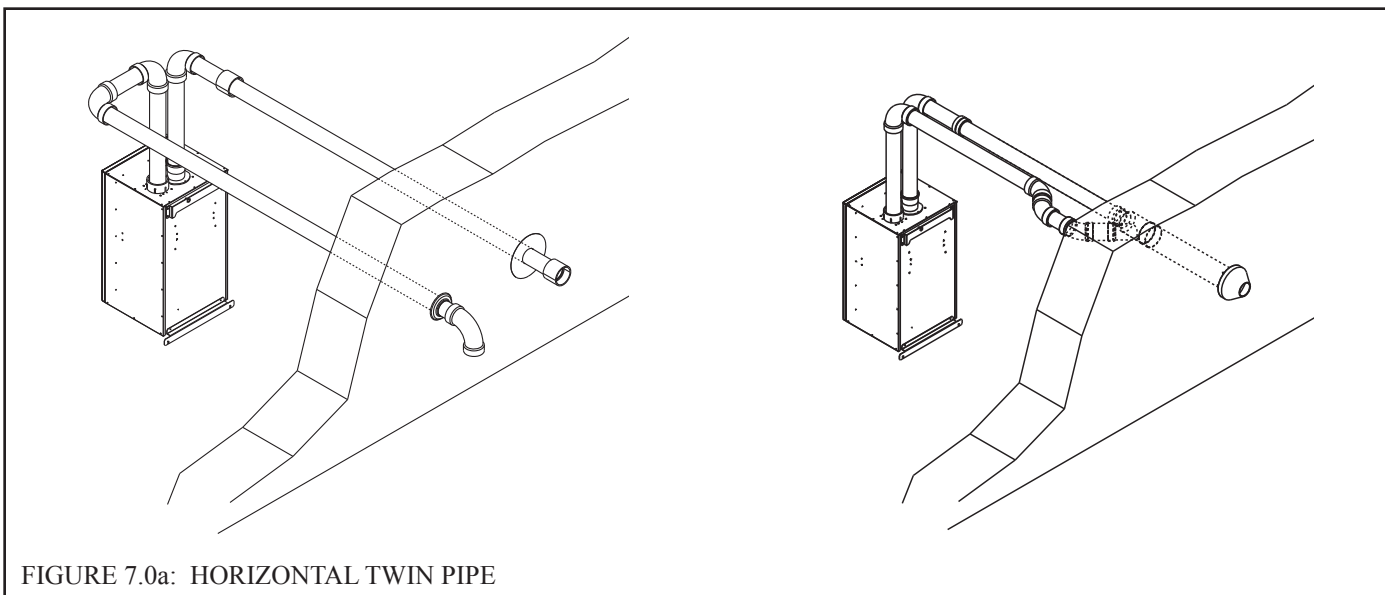

All of these systems are considered “direct vent” because the air for combustion is drawn directly from the outdoors into the boiler. One of the vent option columns in Tables 7.5, 7.11 or 7.15 must match the planned vent and air intake system exactly.

Design details applying to all vent systems are shown in this section. Observe all design requirements in this section, as well as those unique to the type of system being installed:

- B – Design Requirements Unique to Horizontal Twin Pipe Vent Systems
- C - Design Requirements Unique to Vertical Twin Pipe Vent systems
- D- Design Requirements Unique to Split Vent Systems

1. Approved Vent Systems and Materials – The following materials and vent systems may be used to vent this boiler:

- CPVC – Use only CPVC listed to ASTM F441. In Canada, this pipe must also be listed to ULC S636.
- PVC – PVC may be used only as permitted in this manual. All PVC must be listed to ASTM D2665. At least 30” of CPVC pipe, and at least one CPVC elbow, must be installed between the boiler’s vent connection and the PVC pipe. Use of foam core PVC is not permitted for venting. PVC vent pipe may not be used to vent this boiler in Canada.

Use PVC and/or CPVC for the air intake system. PVC may be used for all air intake piping between the intake terminal and the boiler.

When CPVC and/or PVC pipe is used, it must be joined using primer and cement that is listed for use with the pipe material being joined (PVC, CPVC, or CPVC to PVC).

2. Vent Kits Available for Use with this Boiler – The following vent kits are available for CPVC/PVC vent systems installed with this boiler in the USA:
- 107039-01 - 2” CPVC/PVC Vent Kit
 - 107039-02 – 3” CPVC/PVC Vent Kit

These kits include the following:

- (1) 30” CPVC Straight Pipe
- (1) 90 degree short bend CPVC Elbow
- (1) Straight PVC Coupling (for exhaust terminal)
- (1) 90 degree PVC Elbow (for intake termination)
- (2) Rodent screens

The CPVC Pipe and elbow supplied with these kits are not listed to ULC S636 and may not be used in Canada.

NOTICE

When 3” venting is used with the 80 or 100 models, a 2” x 3” CPVC Increaser and a short length of 2” CPVC pipe will be required to adapt from the 2” vent collar to the 3” components in the 107039-02 kit. These items are not included in the kit itself.

3. Maximum Vent and Air Intake Lengths - The maximum length of the vent/air intake piping depends upon the vent option selected and the boiler size. See Tables 7.5, 7.11 or 7.15 for the maximum vent lengths. These maximum lengths apply to both the vent and intake piping (e.g. Option 1 may have up to 60ft of intake and 60ft of vent piping). For all vent systems, the lengths shown in Tables 7.5, 7.11 and 7.15 are in addition to the first 90° elbow. If more elbows are desired, the maximum allowable vent length must be reduced by the amount shown in Table 7.1 for each additional elbow used. Termination fittings are never counted.

It is recommended that all field supplied PVC or CPVC elbows be “1/4 Bend” (Sanitary 90° El) or “Long Sweep 1/4 Bend” type elbows (Figure 7.2). In this manual “sanitary” and “long sweep” elbows are treated as having the same equivalent length.

Example:

A 3” twin pipe horizontal CPVC/PVC vent system is planned for a horizontally vented 120MBH model which has the following components in the vent system:

- 1 ft CPVC Straight Pipe
- 90 CPVC Elbow (short bend)
- 1-1/2 ft CPVC Straight Pipe
- Coupling
- 10 ft PVC Straight Pipe
- 90 PVC Elbow (Sanitary Elbow Design)
- 15 ft PVC Straight Pipe
- PVC Coupling Terminal

The Vent Option #2 column in Table 7.5 describes a horizontal direct vent system using 3” CPVC and PVC pipe. From this column, we see that the boiler may have a vent length of up to 135ft. The first CPVC 90 degree elbow is not considered. From Table 7.1, we see that the equivalent length of the 90 PVC elbow is 4ft and that the equivalent length of the coupling is 0ft. The total equivalent length of the planned venting system is therefore:

1ft (Straight CPVC) + 0ft (first short bend CPVC 90 Elbow) + 1.5ft (Straight CPVC) + 0ft (Coupling) + 10ft (Straight PVC) + 4ft (PVC 90 Sanitary Elbow) + 15ft (Straight PVC) + 0ft (Coupling Terminal) = 31.5ft.

Since Table 7.5 shows a maximum allowable vent length of 135ft, the planned vent system length is acceptable

NOTICE

Do not exceed maximum vent/combustion air system length. Refer to Tables 7.5, 7.11 and 7.15 in this section for maximum vent/combustion air system length.

Use only vent and combustion air terminals and terminal locations shown in Tables 7.5, 7.11 and 7.15 and related Figures.

TABLE 7.1: VENT/ AIR INTAKE FITTING EQUIVALENT LENGTH

CPVC/PVC FITTING	EQUIVALENT LENGTH (ft)
2" 90 ELBOW ("SANITARY BEND")	2.6
3" 90 ELBOW ("SANITARY BEND")	4.0
2" 90 ELBOW ("SHORT BEND")	6.0
3" 90 ELBOW ("SHORT BEND")	10.0
2" 45 ELBOW	1.5
3" 45 ELBOW	2.0
2" COUPLING	0.0
3" COUPLING	0.0

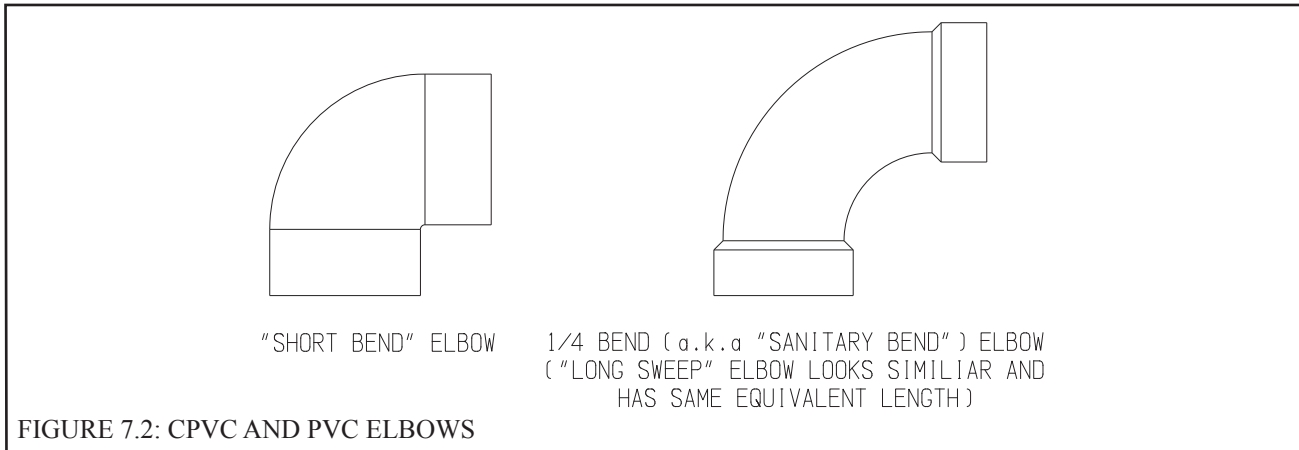

FIGURE 7.2: CPVC AND PVC ELBOWS

4. Minimum Vent and Air Intake Lengths - Observe the minimum vent lengths shown in Tables 7.5, 7.11 and 7.15.

5. Clearances to Combustibles - Maintain the following clearances from the vent system to combustible construction:

- Vent - 1/4" (also observe clearances through both combustible and non-combustible walls - see 9 below)
- Air Intake - 0"
- Concentric Portion of Concentric Terminals - 0"

6. Pitch of Horizontal Vent Piping - Pitch all horizontal CPVC/PVC vent piping 1/4" per foot so that any condensate which forms in the piping will run towards the boiler.

Les chaudières de catégories I, II et IV doivent présenter des tronçons horizontaux dont la pente montante est d'au moins 5/8 po par pied (52 mm/m) entre la chaudière et l'évent.

7. Supporting Pipe - Vertical and horizontal sections of pipe must be properly supported. Maximum support spacing is 4 feet.

Les instructions d'installation du système d'évacuation doivent préciser que les sections horizontales doivent être supportées pour prévenir le fléchissement. Les méthodes et les intervalles de support doivent être spécifiés. Les instructions doivent aussi indiquer les renseignements suivants:

- les chaudières de catégories II et IV doivent être installées de façon à empêcher l'accumulation de condensat: et
- si nécessaire, les chaudières de catégories II et IV doivent être pourvues de dispositifs d'évacuation du condensat.

8. Allowing for Thermal Expansion -

- Design the vent system to allow 3/8" of thermal expansion for every 10ft of CPVC/PVC pipe. The boiler will always act as an anchor to one end of the vent system. If at all possible, select and install hangers and wall thimbles so that the vent system can expand towards the terminal. When a straight run of pipe exceeds 20ft and must be restrained at both ends, an offset or expansion loop must be provided (Figures 7.3a, 7.3b). When a straight horizontal run of pipe exceeds 20ft and is restrained at one end with an elbow at the other, avoid putting a hanger or guide less than "Y" inches from the elbow in the adjoining straight section (Figure 7.3c). Thermal expansion fittings are not permitted.

9. Running PVC Vent Pipe Inside Enclosures and Through Walls - PVC vent pipe must be installed in a manner that permits adequate air circulation around the outside of the pipe:
- Do not enclose PVC venting - Use CPVC in enclosed spaces, even if PVC is installed upstream.
 - PVC venting may not be used to penetrate combustible or non-combustible walls unless all of the following conditions are met:
 - a. The wall penetration is at least 66 inches from the boiler as measured along the vent.
 - b. The wall is 12" thick or less.
 - c. An airspace of at least that shown in Figure 7.4 is maintained around the OD of the vent.
 If any of these conditions cannot be met, use CPVC for the wall penetration.
10. Vent Manufacturer's Instructions – Where applicable, vent system manufacturers may have additional vent system design requirements. Read and follow the vent manufacturer's instructions in addition to those shown here. Where a conflict arises between the two sets of instructions, the more restrictive requirements shall govern.

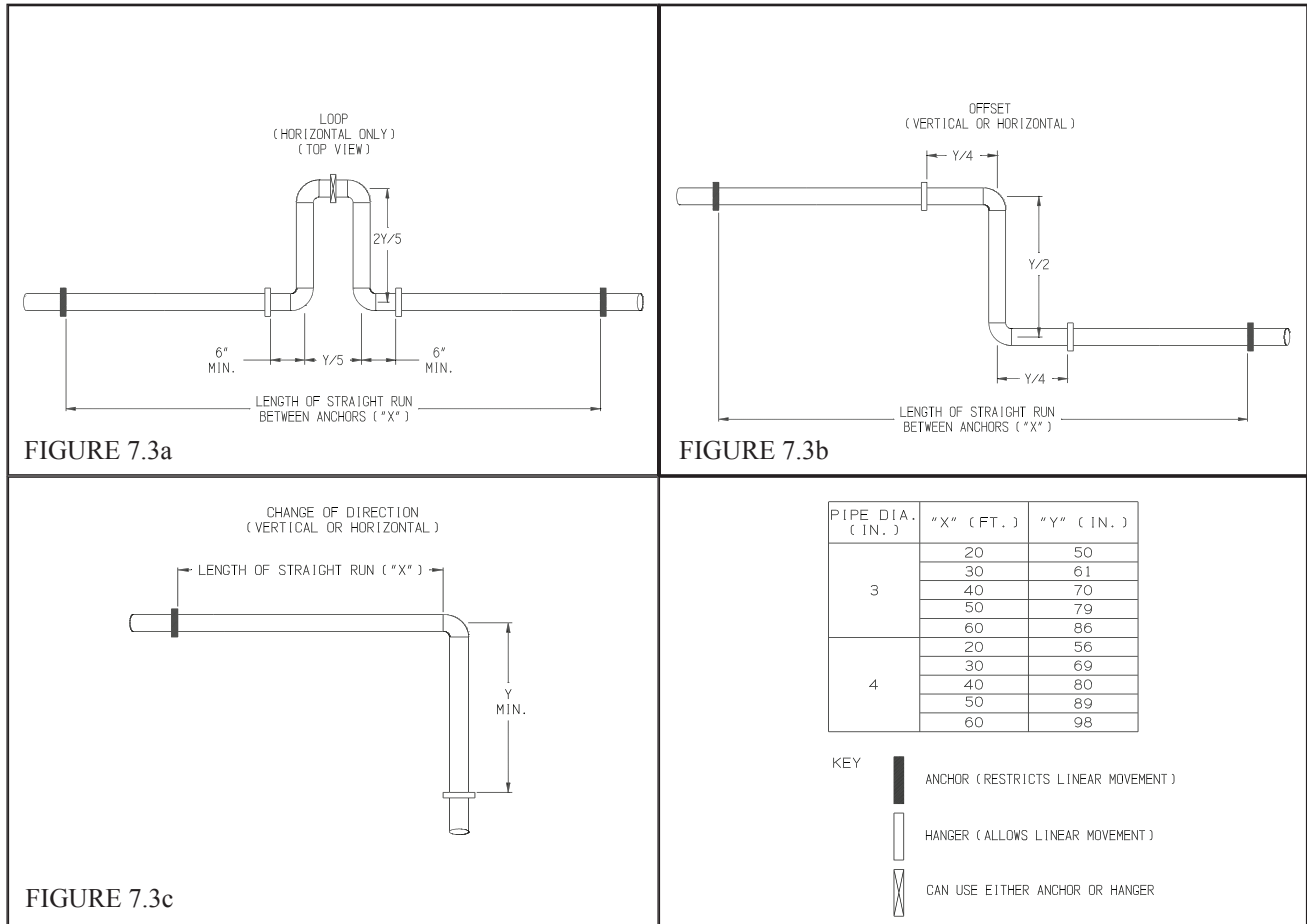

FIGURE 7.3: EXPANSION LOOPS FOR CPVC/PVC PIPE

MAX. WALL THICKNESS ("T")	2"*	6"	12"
MINIMUM AIR SPACE AROUND PIPE ("C")	0"*	1"	1-3/4"

*WALL MUST BE OF NON-COMBUSTIBLE CONSTRUCTION

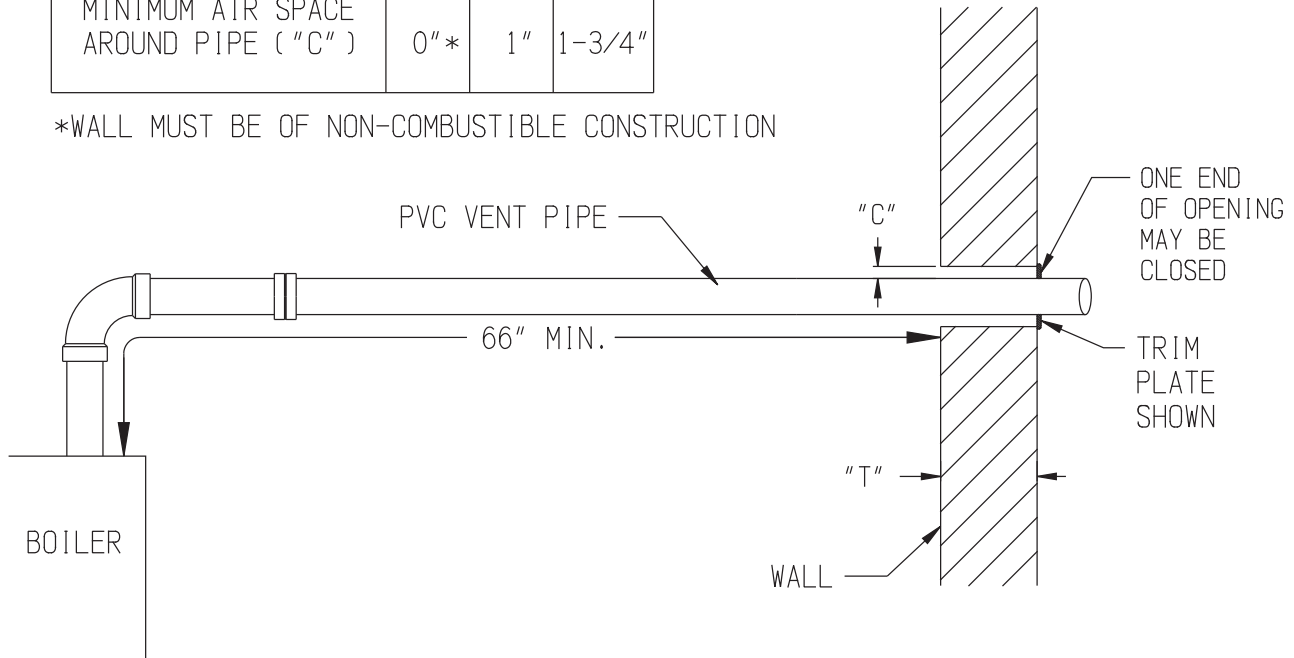

FIGURE 7.4: WALL PENETRATION CLEARANCES FOR PVC VENT PIPE

B. Design Requirements Unique to Horizontal Twin Pipe Venting Systems

Table 7.5 summarizes all horizontal twin pipe vent options. Illustrations of horizontal twin pipe vent systems are shown in Figures 7.7 – 7.9. In addition to the requirements in Part VII-A, observe the following design requirements:

1. Permitted Terminals for Horizontal Venting:

Terminal Option A: Fittings – Vent terminates in a plain end. Intake terminates in a PVC 90 sweep elbow pointing down. Outer edge of both terminals must be within 10” of the wall surface (Figure 7.7).

Use of rodent screens (not supplied) is generally recommended for both terminations. These can be fabricated from 2 x 2 (1/2” mesh) stainless steel screen. They are installed as shown in Figure 7.18.

If necessary to achieve required clearance above grade, CPVC or CPVC/PVC vent systems may be terminated using fittings on snorkels as shown in Figure 7.6. When this is done, the equivalent length of all pipe on the exterior of the building, except for the terminal fittings themselves, must be counted when calculating the equivalent length. The maximum vertical run of the snorkel is 7 feet. Brace both the vent and inlet piping if required.

Terminal Option B: IpeX Low Profile Terminal – This terminal is shown in Figure 7.8. If the terminal is oriented vertically (alternate orientation shown in Fig 7.8) the exhaust opening must be on the top as shown. See Part VII-E of this manual and the IpeX instructions provided with the terminal, for installation details.

Terminal Option C: Diversitech “Low Profile” Terminal – This terminal is shown in Figure 7.8. If the terminal is oriented vertically (alternate orientation shown in Fig 7.8) the exhaust opening must be on the top as shown. See Part VII-E of this manual and the Diversitech instructions provided with the terminal, for installation details.

Terminal Option D: IpeX FGV Concentric Terminal - This terminal is shown in Figure 7.9 and may be used with CPVC/PVC vent systems. This terminal is available in various lengths and in both PVC and CPVC. Terminals acceptable for use with these vent options are as follows:

IpeX PN	FGV Concentric Terminal Description
196005	2 x 16” PVC
196105	2 x 28” PVC
196125	2 x 40” PVC
196006	3 x 20” PVC
196106	3 x 32” PVC
196116	3 x 44” PVC
197107	3 x 32” CPVC
197117	3 x 44” CPVC

See Part VII-E of this manual and the IpeX instructions provided with the terminal, for installation details.

Terminal Option E: Diversitech Concentric Terminal - This terminal is shown in Figure 7.9 and may be used with CPVC/PVC vent systems. See Part VII-E of this manual and the Diversitech instructions provided with the terminal, for installation details.

- ### 2. Horizontal Vent and Air Intake Terminal Location - Observe the following limitations on the vent terminal location (also see Figure 7.10). When locating a concentric terminal, observe the limitations outlined below for “vent terminals”.
- Vent terminal must be at least 1 foot from any door, window, or gravity inlet into the building.
 - When Terminal Option A (fittings) are used, maintain the correct clearance and orientation between the intake and exhaust terminals. The recommended horizontal spacing between inlet and exhaust terminals is 36”, however this spacing may be reduced to 12” (center-to-center) if necessary. The elevation of the exhaust terminal must be at, or above, that of the intake terminal. The 12” minimum horizontal spacing must be maintained regardless of the vertical separation between the intake and exhaust terminals. Both terminals must be located on the same wall.
 - The bottom of all terminals must be at least 12” above the normal snow line. In no case should they be less than 12” above grade level.
 - The bottom of the vent terminal must be at least 7 feet above a public walkway.
 - Do not install the vent terminal directly over windows or doors.
 - The bottom of the vent terminal must be at least 3 feet above any forced air inlet located within 10 feet.
 - USA Only: A clearance of at least 4 feet horizontally must be maintained between the vent terminal and gas meters, electric meters, regulators, and relief equipment. Do not install vent terminal over this equipment. In Canada, refer to B149.1 Installation Code for clearance to meters, regulators and relief equipment.
 - Do not locate the vent terminal under decks or similar structures.
 - Top of terminal must be at least 24” below ventilated eaves, soffits and other overhangs. In no case may the overhang depth exceed 48”. Where permitted by the authority having jurisdiction and local experience, the terminal may be located closer to unventilated soffits. The minimum vertical separation depends upon the depth of the soffit. See Figure 7.10 for details.
 - Vent terminal must be at least 6 feet from an inside corner.

Table 7.5: Summary of Horizontal Twin Pipe Venting Options

Vent Option		1	2
Illustrated in Figure		7.7, 7.8, 7.9	7.7, 7.8, 7.9
Pipe Penetration through Structure	Vent	Wall	Wall
	Intake	Wall	Wall
Material	Vent	CPVC/PVC (Note 2)	CPVC/PVC (Note 2)
	Intake	PVC	PVC
Nominal Diameter	Vent	2"	3" (Note 4)
	Intake	2"	3" (Note 4)
Min Equivalent Vent Length:			
Models	080	12"	12"
	100	12"	12"
	120	Not Permitted	12"
	150		52"
	180		52"
Max Equivalent Vent Length (Note 1):			
Models	080	60ft	135ft
	100	60ft	135ft
	120	Not Permitted	135ft
	150		135ft
	180		135ft
Terminal Option A (Fittings)	Vent	Coupling w Screen (Note 3)	Coupling w Screen (Note 3)
	Intake	Elbow w Screen (Note 3)	Elbow w Screen (Note 3)
Terminal Option B (Iplex Low Profile)		Iplex # 196984	Iplex #196985
Terminal Option C (Diversitech HVENT)		HVENT-2	HVENT-3
Terminal Option D (Iplex FGV Concentric)		Iplex 196105	Iplex 196006
Terminal Option E (Diversitech CVENT)		CVENT-2	CVENT-3

Notes:

- 1) Max vent lengths shown also apply to the intake. For example, Vent Option #1 may have up to 60ft of vent pipe and also up to 60 ft of intake pipe.
- 2) First 30" of vent and vent Elbow connected to boiler must be CPVC. Downstream vent pipe can be PVC except as noted in text.
- 3) PVC Terminal coupling and inlet elbow may be offset on snorkels as shown in Figure 7.6.
- 4) For models 80 and 100: Make increase in vent diameter from 2 to 3" at boiler collar (before first elbow). Reduce intake diameter from 3" to 2" at intake collar.

- Under certain conditions, water in the flue gas may condense, and possibly freeze, on objects around the vent terminal including on the structure itself. If these objects are subject to damage by flue gas condensate, they should be moved or protected.
- Install the vent and air intake terminals on a wall away from the prevailing wind. Reliable operation of this boiler cannot be guaranteed if these terminals are subjected to winds in excess of 40 mph.
- Air intake terminal must not terminate in areas that might contain combustion air contaminants, such as near swimming pools. See WARNING on page 11.

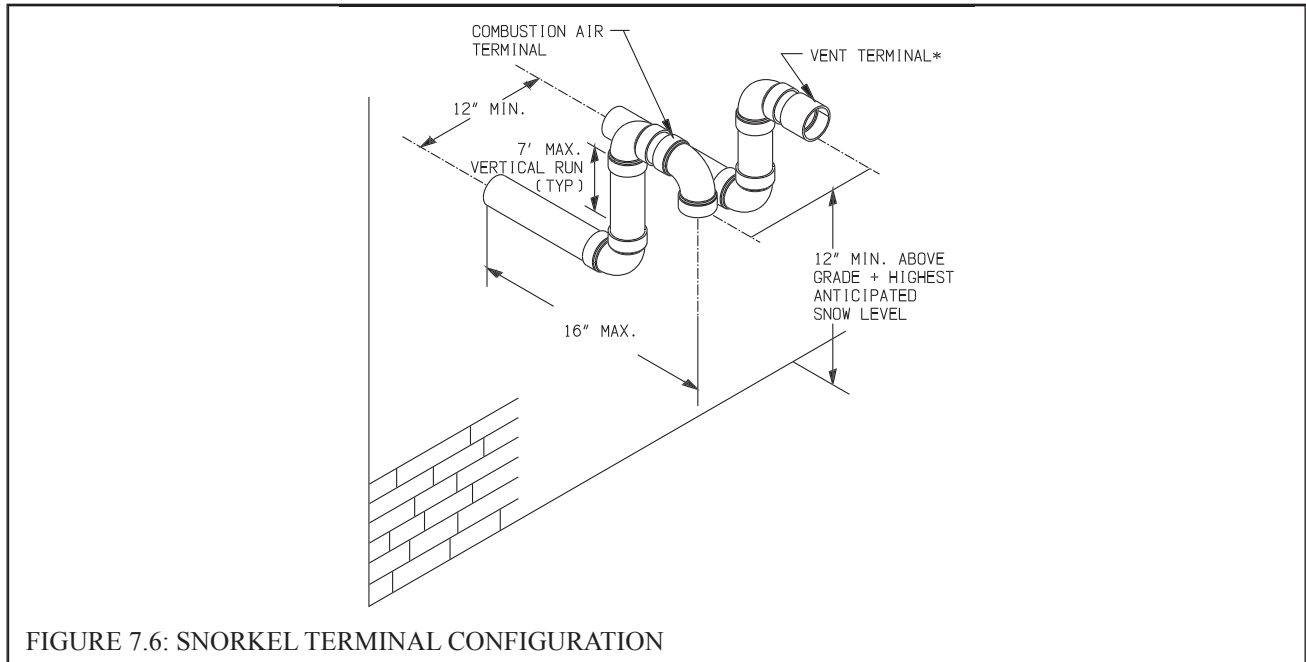
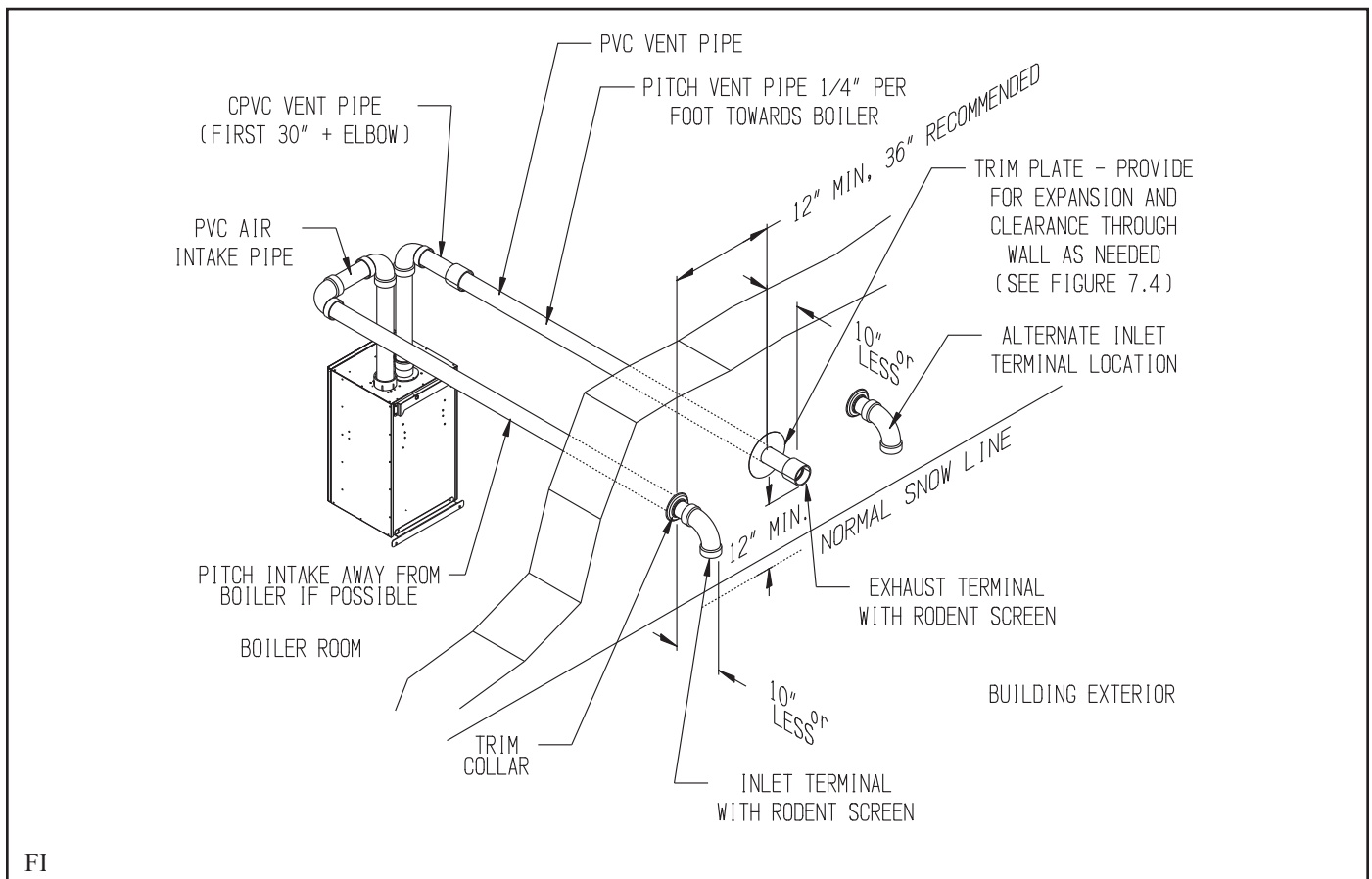

FIGURE 7.6: SNORKEL TERMINAL CONFIGURATION



FI

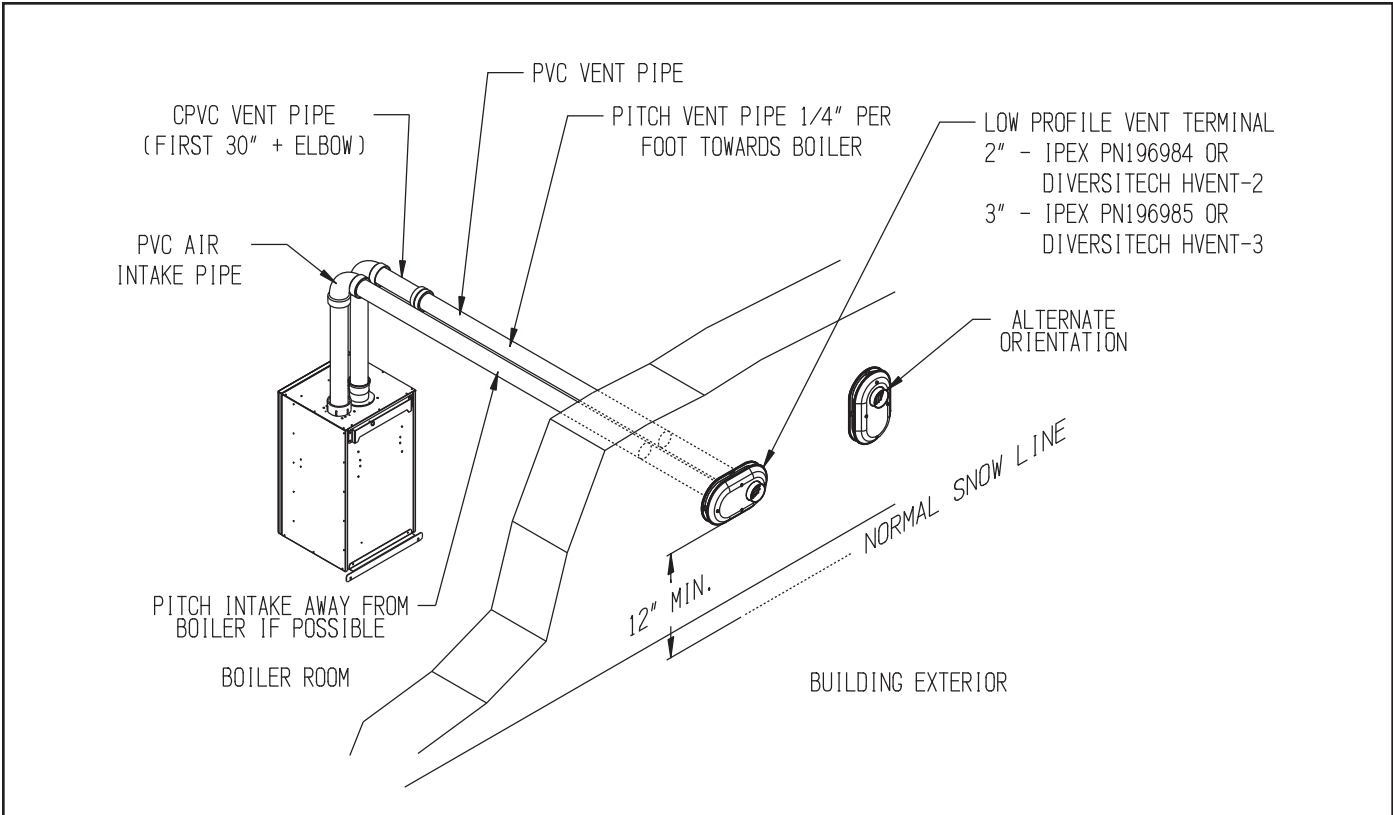

FIGURE 7. 8: HORIZONTAL CPVC/PVC VENTING WITH LOW PROFILE TERMINAL,
(VENT OPTIONS #1 & 2, TERMINAL OPTIONS B & C)

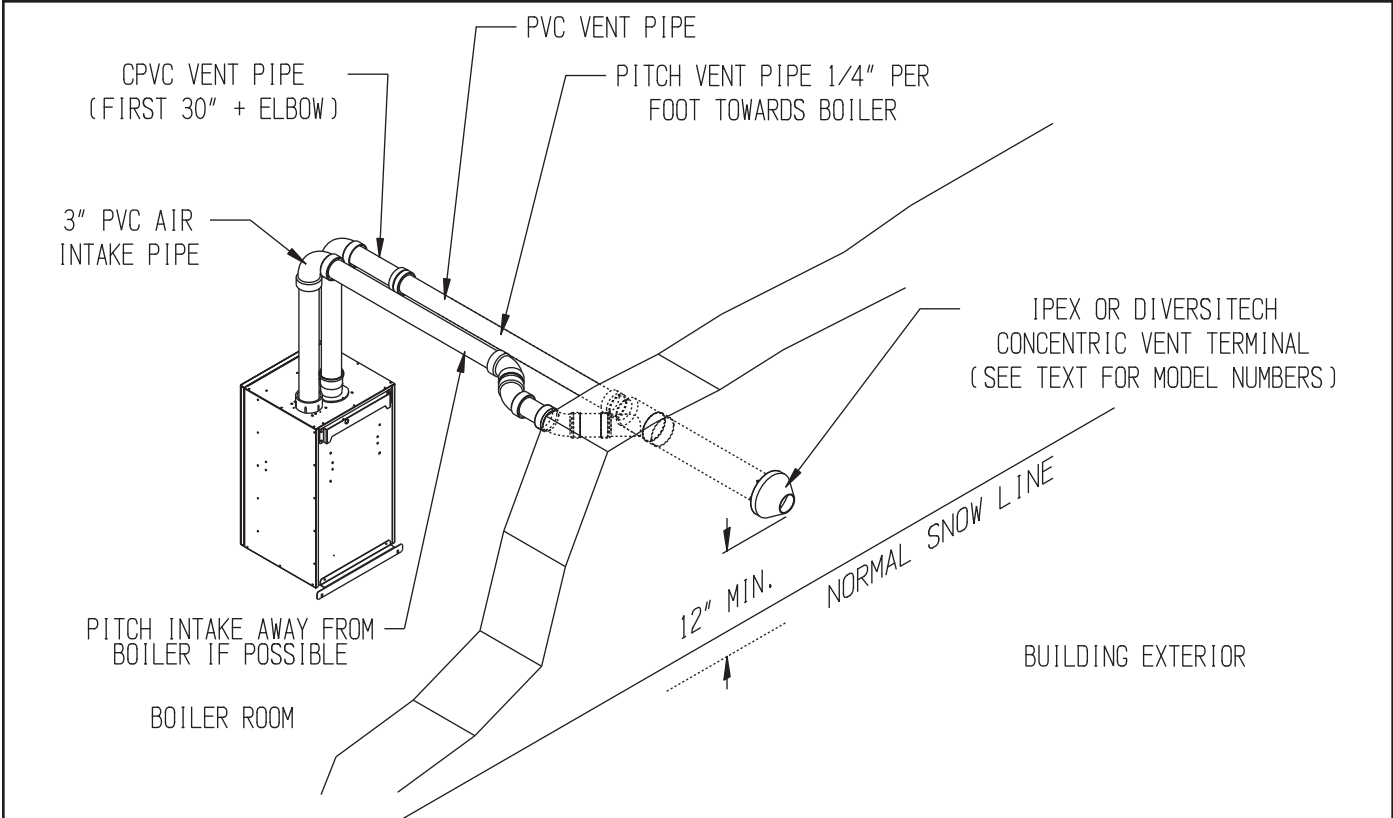
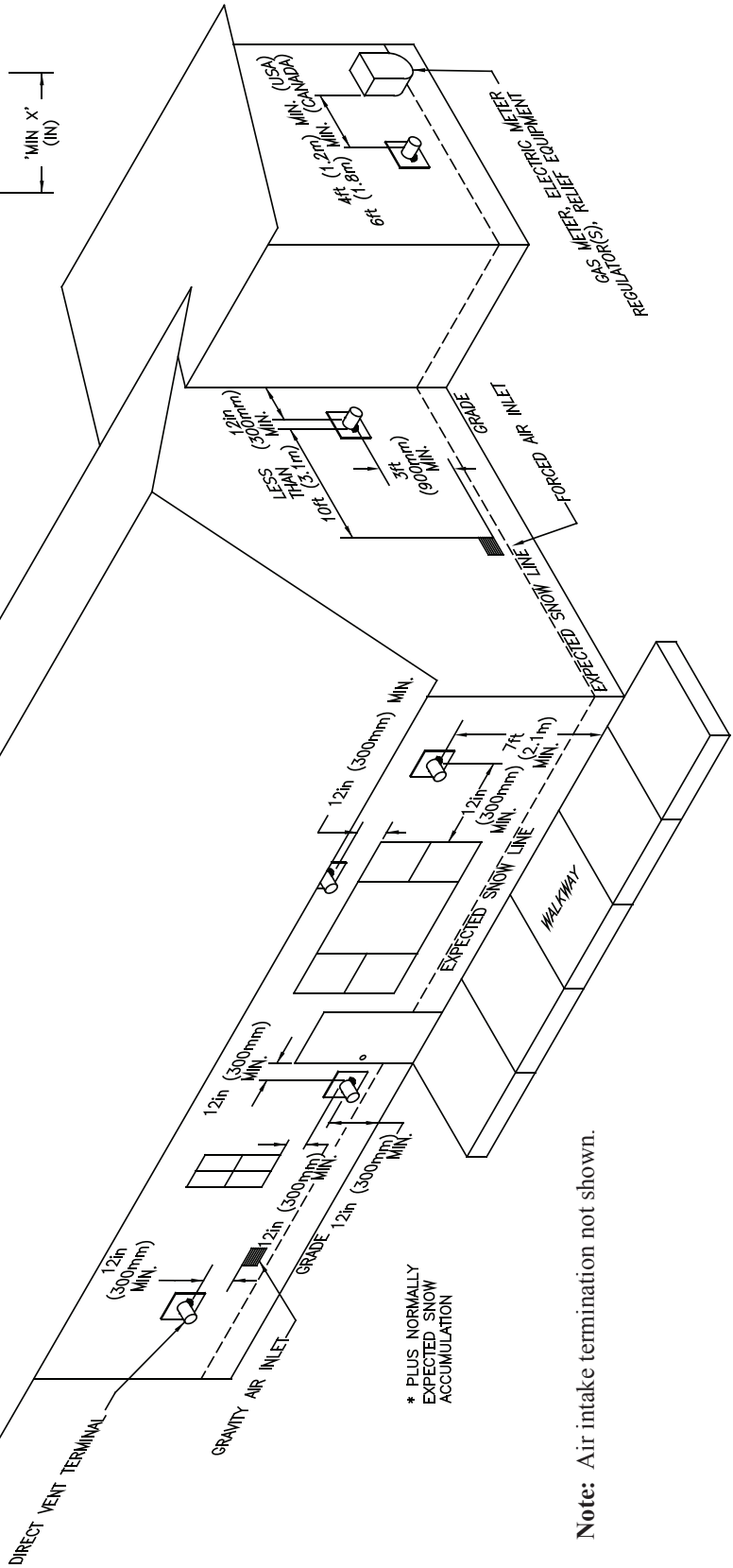
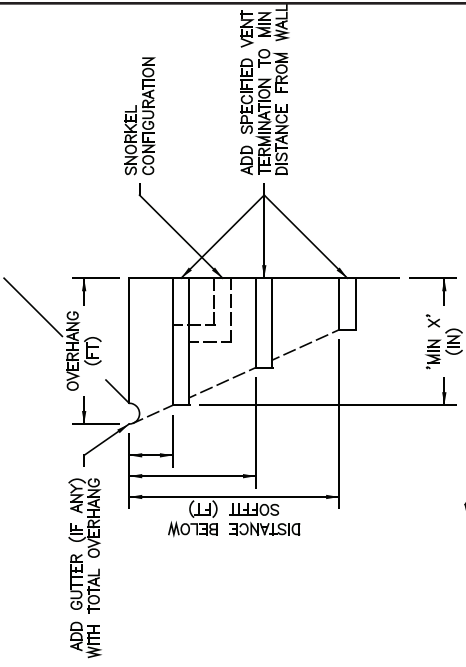

FIGURE 7.9: HORIZONTAL CPVC/PVC WITH CONCENTRIC VENT TERMINAL,
(VENT OPTIONS #1 & 2, TERMINAL OPTIONS D & E)

DISTANCE BELOW UNVENTILATED SOFFIT	DISTANCE BELOW VENTILATED SOFFIT	OVERHANG (FT)			
		0 FT - 1 FT	1 FT - 2 FT	2 FT - 3 FT	3 FT - 4 FT
1 FT - 2 FT	-	12"	12"	12"	12"
2 FT - 3 FT	2 FT - 3 FT	12"	12"	12"	12"
3 FT - 4 FT	3 FT - 4 FT	12"	12"	12"	12"
4 FT - 5 FT	4 FT - 5 FT	12"	12"	12"	12"
OVER 5 FT	OVER 5 FT	12"	12"	12"	12"



Note: Air intake termination not shown.

FIGURE 7.10: LOCATION OF VENT TERMINAL RELATIVE TO WINDOWS, DOORS, GRADES, OVERHANGS, METERS AND FORCED AIR INLETS - TWO PIPE SYSTEM VENT TERMINAL (SHOWN) TWO-PIPE SYSTEM AIR INTAKE TERMINAL (NOT SHOWN)

C. Design Requirements Unique to Vertical Venting Systems

Table 7.11 summarizes all vertical twin pipe vent options. In addition to the requirements in Part VII-A, observe the following design requirements:

1. Permitted Terminals for Vertical Venting

Terminal Option H: Fittings – Vent terminates in a plain end (coupling for PVC. Intake terminates in a PVC 180 elbow pointing down (two sweep 90's may be substituted). Observe the clearances from the roof, and normal snow line on the roof, shown in Figures 7.12 and 7.13.

Use of rodent screens (not supplied) is generally recommended for both terminations. These can be fabricated from 2 x 2 (1/2" mesh) stainless steel screen. They are installed as shown in Figure 7.18.

Terminal Option I: Ipex FGV Concentric Terminal - This terminal is shown in Figure 7.13 and may be used with CPVC/PVC vent systems. Use a compatible roof flashing and storm collar in accordance with the Ipex instructions for this terminal. This terminal is available in various lengths and in both PVC and CPVC. Terminals acceptable for use with these vent options are as follows:

Ipex PN	FGV Concentric Terminal Description
196005	2 x 16" PVC
196105	2 x 28" PVC
196125	2 x 40" PVC
196006	3 x 20" PVC
196106	3 x 32" PVC
196116	3 x 44" PVC
197107	3 x 32" CPVC
197117	3 x 44" CPVC

See Part VII-E of this manual and the Ipex instructions provided with the terminal, for installation details.

Terminal Option J: Diversitech Concentric Terminal - This terminal is shown in Figure 7.13 and may be used with CPVC/PVC vent systems. See Part VII-E of this manual and the Diversitech instructions provided with the terminal, for installation details.

2. Vertical Vent and Air Intake Location – Observe the following clearances from roof mounted terminals:

- Bottom of air intake opening must be at least 12" above the normal snow line anticipated on the roof.
- Exhaust opening must be at least 2ft above any portion of the roof or structure located within horizontally within 10ft.
- For terminal option H, maintain at least 12" of vertical separation between the exhaust and intake opening as shown in Figure 7.12.

NOTICE

Vertical venting and combustion air roof penetrations (where applicable) require the use of roof flashing and storm collar, which are not supplied with the boiler, to prevent moisture from entering the structure.

Table 7.11: Summary of Vertical Twin Pipe Venting Options

Option		10	11
Illustrated in Figure		7.12, 7.13	7.12, 7.13
Pipe Penetration through Structure	Vent	Roof	Roof
	Intake	Roof	Roof
Material	Vent	CPVC/PVC (Note 2)	CPVC/PVC (Note 2)
	Intake	PVC	PVC
Nominal Diameter	Vent	2"	3" (Note 4)
	Intake	2"	3" (Note 4)
Min Equivalent Vent Length:			
Models	080	12"	12"
	100	12"	12"
	120	Not Permitted	12"
	150		52"
	180		52"
Max Equivalent Vent Length (Note 1):			
Models	080	60ft	135ft
	100	60ft	135ft
	120	Not Permitted	135ft
	150		135ft
	180		135ft
Terminal Option H (Fittings)	Vent	Coupling w Screen	Coupling w Screen
	Intake	180 Elbow w Screen	180 Elbow w Screen
Terminal Option I (Ipex FGV Concentric)		Ipex 196105 (Note 3)	Ipex 196006 (Note 3)
Terminal Option J (Diversitech CVENT Concentric)		CVENT-2	CVENT-3

Notes:

- 1) Max vent lengths shown also apply to the intake. For example, Vent Option #10 may have up to 60ft of vent pipe and also up to 60 ft of intake pipe.
- 2) First 30" of vent and vent Elbow connected to boiler must be CPVC. Downstream vent pipe can be PVC except as noted in text.
- 3) Ipex FGV Concentric Terminal available in various lengths and also CPVC (see text).
- 4) For models 80 and 100: Make increase in vent diameter from 2 to 3" at boiler collar (before first elbow). Reduce intake diameter from 3" to 2" at intake collar.

All vertical terminals require compatible roof flashing and storm collars.

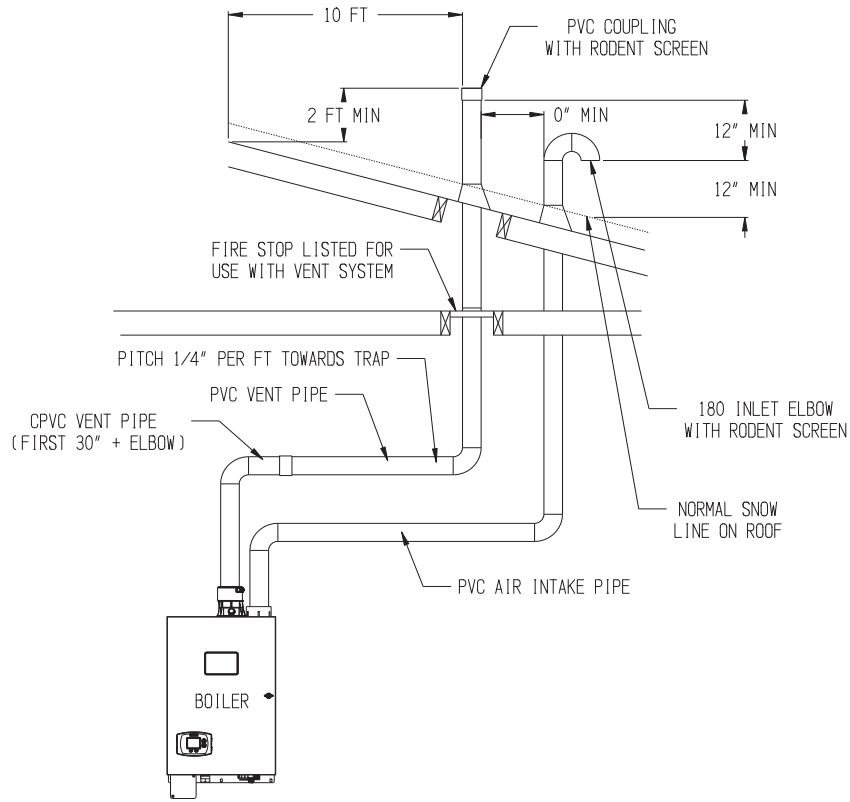

FIGURE 7.12: VERTICAL CPVC/PVC VENTING, (VENT OPTIONS 10 & 11, TERMINAL OPTION H)

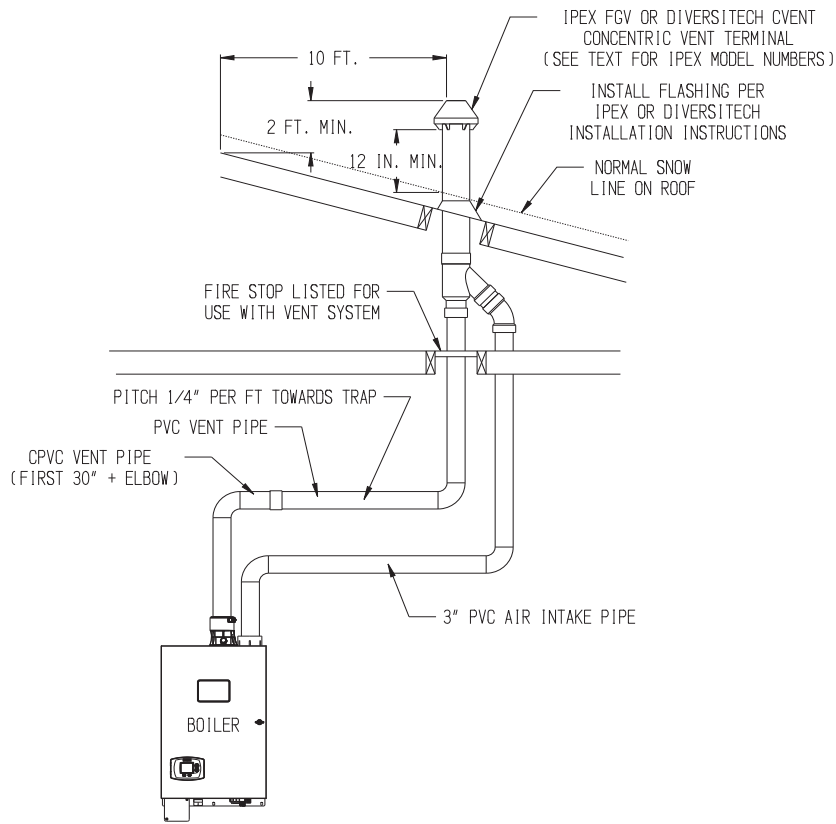

FIGURE 7.13: VERTICAL CPVC/PVC VENTING WITH IPEX CONCENTRIC VENT TERMINAL, (VENT OPTIONS #10 & 11, TERMINAL OPTIONS I, J)

D. Design Requirements Unique to Split Vent Systems

Table 7.15 summarizes all split vent options. Illustrations of split vent systems are shown in Figure 7.14. In addition to the requirements in Part VII-A, observe the following design requirements:

1. Permitted Terminals for Split Venting:

Rigid Vent Systems (Vent Options 25-26) – Vent terminates in a plain end (coupling for PVC). Intake terminates in a PVC 90 sweep elbow pointing down.

Use of rodent screens (not supplied) is generally recommended for both terminations. These can be fabricated from 2 x 2 (1/2" mesh) stainless steel screen. They are installed as shown in Figure 7.18.

Air Intake Terminals (Vent Options 25-26) - All split venting options shown in Tables 7.15 terminate in a PVC 90 sweep elbow pointing down. Use of a rodent screen is generally recommended for the intake termination.

2. Vent Terminal Location – Observe the following clearances from roof mounted vent terminals (also see Figure 7.14):

- Bottom of terminal must be at least 12" above the normal snow line anticipated on the roof.
- Exhaust opening must be at least 2ft above any portion of the roof or structure located within horizontally within 10ft.

3. Horizontal Air Intake Terminal Location - Observe the following limitations on the intake terminal location (also see Figure 7.14):

- The bottom of all terminals must be at least 12" above the normal snow line. In no case should they be less than 12" above grade level.
- If possible, install the intake terminal on a wall away from the prevailing wind. Reliable operation of this boiler cannot be guaranteed if the intake terminal is subjected to winds in excess of 40 mph.
- Air intake terminal must not terminate in areas that might contain combustion air contaminants, such as near swimming pools. See WARNING on page 11.

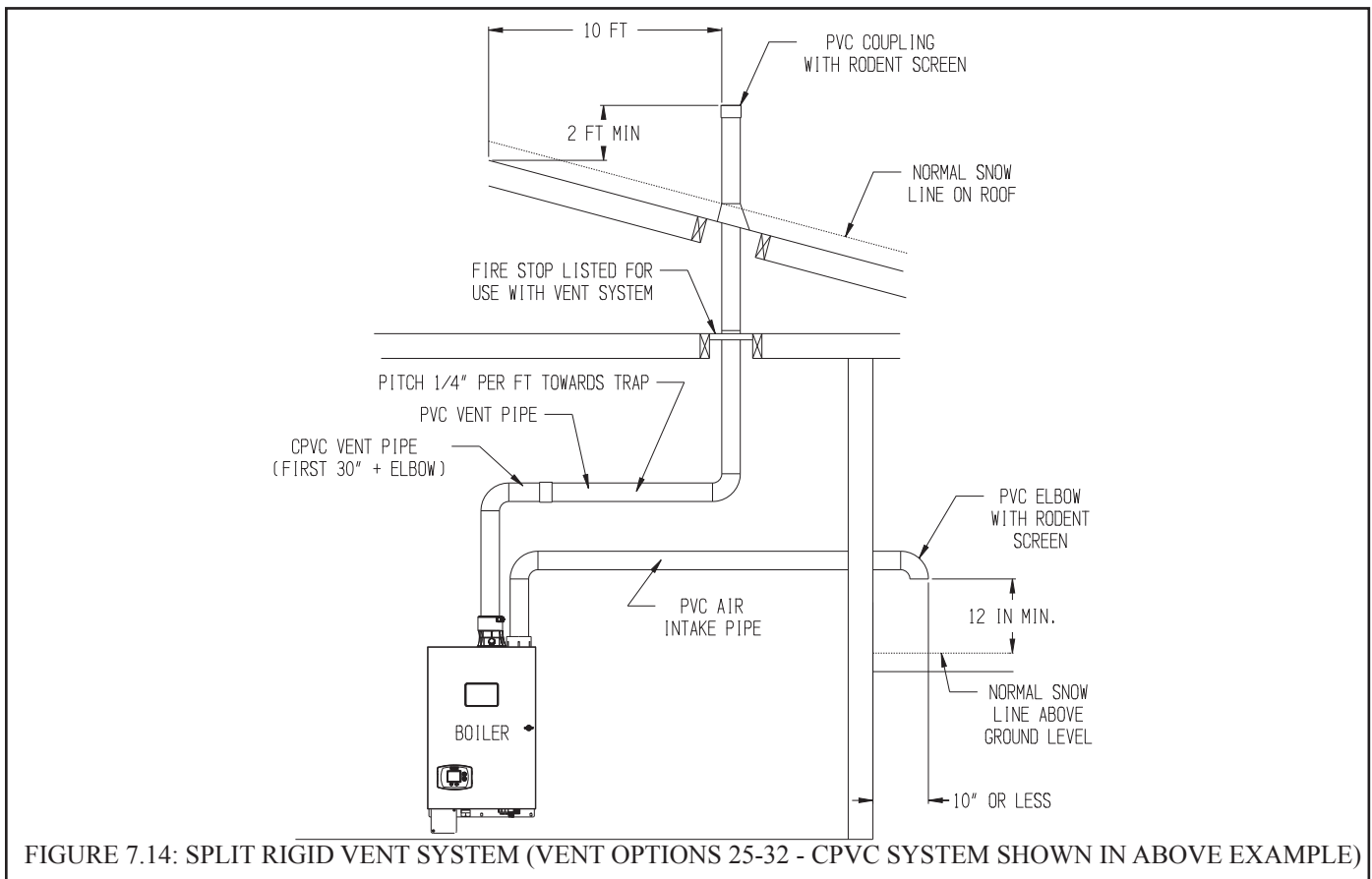

Table 7.15: Summary of Split Vent System Options

Option #		25	26
Illustrated in Figure		7.14	7.14
Pipe Penetration Through Structure	Vent	Roof	Roof
	Intake	Wall	Wall
Material	Vent	CPVC/PVC (Note 2)	CPVC/PVC (Note 2)
	Intake	PVC	PVC
Nominal Diameter	Vent	2"	3" (Note 3)
	Intake	2" or 3"	3" (Note 3)
Min Equivalent Vent Length:			
Models	080	48"	48"
	100	48"	48"
	120		48"
	150		52"
	180		52"
Max Equivalent Vent Length (Note 1):			
Models	080	60ft	135ft
	100	60ft	135ft
	120		135ft
	150		135ft
	180		135ft
Rigid Vent Terminals	Vent	Coupling w Screen	Coupling w Screen
	Intake	90 Elbow w Screen	90 Elbow w Screen

- 1) Max vent lengths shown also apply to the intake.
- 2) First 30" plus first exhaust elbow are CPVC.
- 3) For models 80 and 100: Make increase in vent diameter from 2 to 3" at boiler collar (before first elbow). Reduce intake diameter from 3" to 2" at intake collar.

All vertical terminals require compatible roof flashing and storm collars.

E. Assembly of CPVC/PVC Vent Systems



WARNING

- **Asphyxiation Hazard.** Failure to follow these instructions could cause products of combustion to enter the building, resulting in severe property damage, personal injury, or death.
- **A CPVC elbow and a 30" straight section of CPVC (not supplied) must be installed at the boiler end of the vent system before transitioning to Schedule 40 PVC pipe (ASTM 2665) components for remainder of vent system.**
- **Use CPVC vent components within any interior space where air cannot circulate freely, including through vertical or horizontal chase ways, inside a stud wall, in closets and through wall penetrations.**
- **The use of cellular core PVC (ASTM F891), cellular core CPVC or Radel (polyphenolsulfone is prohibited.**
- **All condensate that forms in the vent must be able to drain back to the boiler.**
- **Never leave the boiler in operation without the gas sample cap in place (Figure 7.17)**

1. Assemble the vent system, starting at the boiler:

- a. A CPVC elbow and a 30" straight section of CPVC (not supplied) must be used before transitioning to PVC. If necessary the 30" straight section of CPVC may be cut in any location and the CPVC elbow inserted between the two resulting segments.
- b. When cutting CPVC or PVC pipe, use a miter saw or a saw designed to cut PVC pipe. Use a miter box or other method to cut pipe squarely. De-burr both the inside and outside of the cut end.
- c. Dry fit all vent components before assembly.
- d. Lubricate the upper gasket in the vent adaptor with water and insert the first piece of CPVC into the vent adaptor until it bottoms out. Tighten the gear clamp on the adaptor.
- e. Assemble the CPVC elbow and the remainder of the 30" CPVC piping before transitioning to PVC. The first piece of PVC will either be connected to the CPVC elbow or the end of a section of CPVC vent pipe. In the latter case, a PVC coupling may be used to connect the first piece of PVC to the last piece of CPVC.
- f. Clean all CPVC and PVC components with the appropriate primer before cementing. Cement the vent system together, starting at the boiler and following the instructions provided on the cans of cement and primer. Use a field supplied cement and primer that is listed for use with the materials being joined (CPVC and/or PVC). The following, or its equivalent, may be used to join CPVC to PVC:
 - IPS Corporation #P-70 Primer
 - IPS Corporation #790 Multi-Purpose Solvent Cement

Always use primer on both the pipe and fitting before applying the cement. Assemble the pipe in accordance with the instructions on the cans of primer and cement.

- g. Assemble the rest of the vent system, being sure to pitch horizontal sections back towards the boiler 1/4"/ft. Support the vent at intervals not exceeding 4ft.
 - h. Maintain the clearances from the vent pipe outlined in Part VII-A of this manual. If exiting the exterior wall using PVC pipe, use half of an appropriately sized wall thimble (or a sheet metal plate) on the exterior of the building, to provide a weather tight seal while maintaining the proper clearance in the wall penetration. Seal the joint between the pipe and the wall plate using RTV applied on the exterior side of the wall. This sealant must not restrain the expansion of the vent pipe.
2. Installation of Air Intake System - Start assembly of the PVC air intake system at the boiler. Assembly of the air intake system is done in the same manner as the vent system except as follows:
- a. Drill a 7/32" clearance hole into the front side of the air intake adapter. Insert the first piece of PVC air intake pipe into the air intake connection and drill a 1/8" tap hole into the PVC which lines up with the 7/32" clearance hole and secure them together with a #10 x 1" sheet metal screw. Seal the joint between the intake pipe and the adaptor with RTV.
 - b. All intake piping may be PVC.
 - c. There is a 0" minimum clearance between the air intake piping and all types of construction.
 - d. To the extent possible, pitch horizontal air intake piping towards the outdoors.

3. Installation of Horizontal Fitting Terminals (Terminal Option A):

- a. See Figure 7.18 for proper orientation of twin pipe horizontal terminals. Outer edge of both terminals must be within 10" from wall surface. (Figure 7.7)

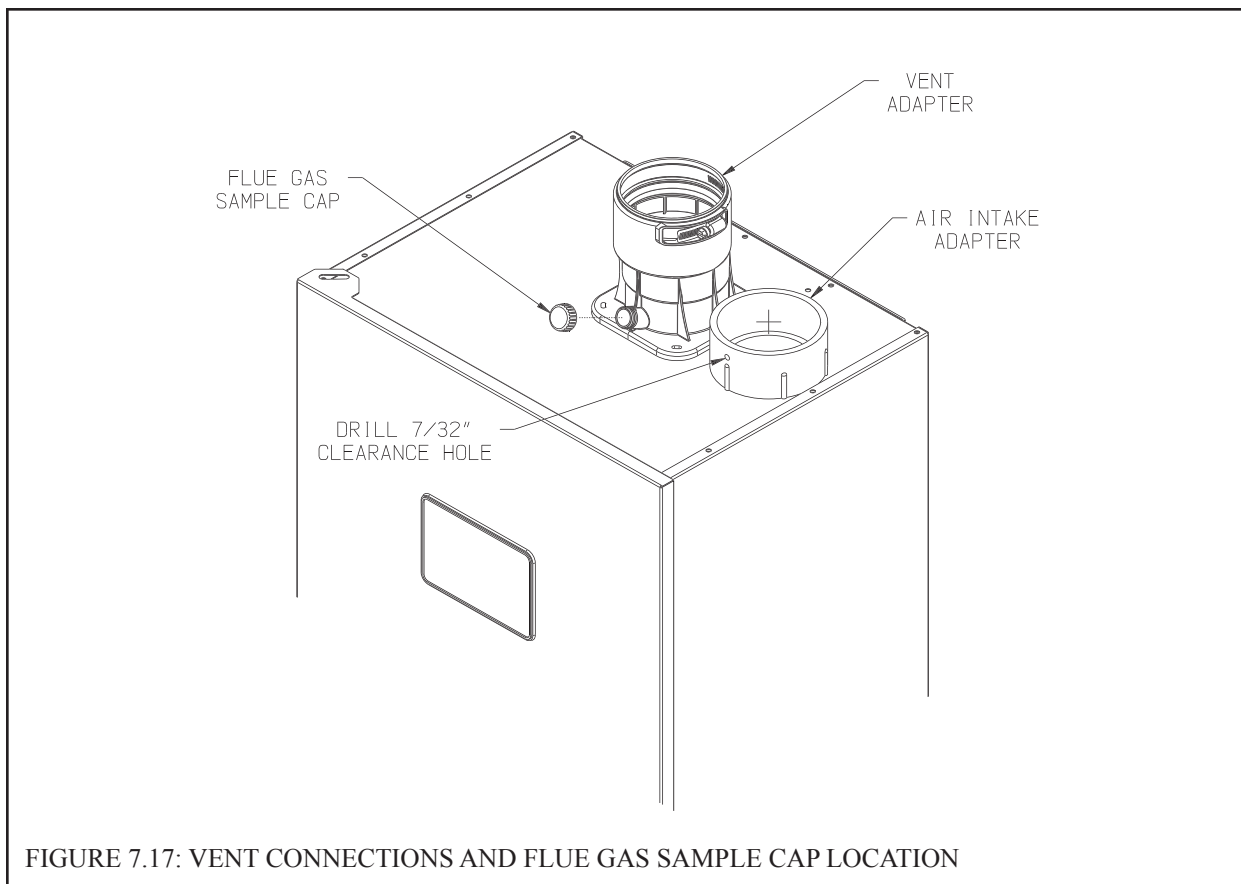

FIGURE 7.17: VENT CONNECTIONS AND FLUE GAS SAMPLE CAP LOCATION

- b. If desired, the terminals can be attached to the end of the vent and/or intake pipes with field supplied stainless steel screws so that they can be later removed for cleaning and inspection. If this is done, drill a clearance hole in the coupling or elbow and a tap hole in the end of the vent/intake pipes to accept these screws.
 - c. If these terminals are installed on snorkels, assemble the snorkels as shown in Figure 7.6. Brace the vertical run of piping on the building exterior as required.
4. Installation of Vertical Fitting Terminals (Terminal Option H):
- a. See Figure 7.19 for the proper orientation of twin pipe vertical terminals.
 - b. The coupling is used to secure the rodent screen to the end of the vent pipe.
 - c. A 180° bend (or two 90° elbows) are installed on the top of the air intake pipe. If two 90° elbows are used, the rodent screen provided can be installed between them (Figure 7.19). If a 180° bend is used, install the rodent screen in the open side of the bend, using a ring made of PVC pipe. If desired, the termination fittings can be attached to the end of the vent and/or intake pipes with field supplied stainless steel screws so that they can be later removed for cleaning and inspection. If this is done, drill a clearance hole in these fittings and a tap hole in the end of the vent/intake pipes to accept these screws.
 - d. Use roof flashings and storm collars to prevent moisture from entering the building. Seal the roof flashing to the roof using generally accepted practice for the type of roof on the installation. Apply RTV to seal the storm collars to the vent and intake pipes.
5. Installation of IPEX low profile vent terminal (Terminal Option B) - See Figure 7.20:
- a. Cut two holes in wall to accommodate the size PVC pipe being used. The distance between hole centers is 5.6”.
 - b. Slide both vent and intake air pipes through the holes. and cement them to the base of the vent termination kit using a primer and cement listed for use with PVC.
 - c. Fasten the vent base to the wall using the supplied screws and anchors. The anchors require the drilling of a 3/16” hole x 1-3/16” deep. Locate the holes using the vent base as a template.
 - d. Screw the vent cap to the vent base using the supplied screws.
 - e. Once the vent termination and pipes are secure seal the wall penetrations from the interior using a weather resistant RTV sealant.
6. Installation of Diversitech Low Profile Terminal (Terminal Option C) – See Figure 7.21:
- a. Use vent plate as a guide to locate the openings for the vent and air intake pipes, as well as to locate the holes for the mounting screws.

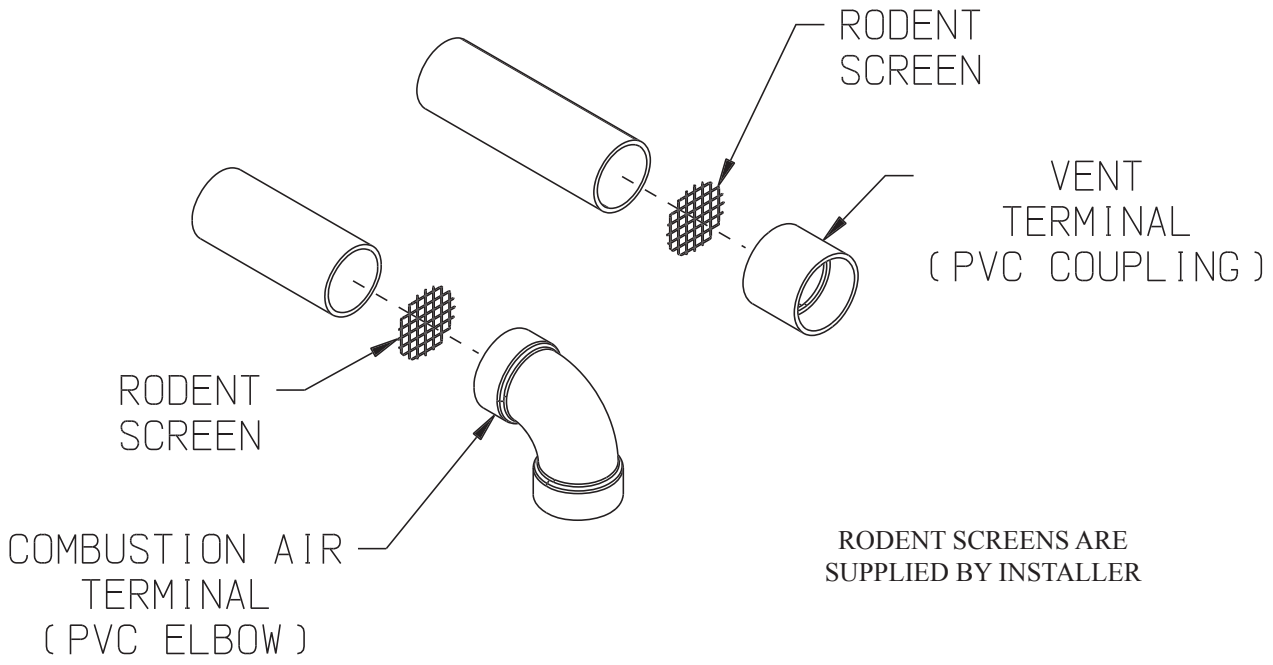

FIGURE 7.18: INSTALLATION OF STANDARD HORIZONTAL TERMINALS

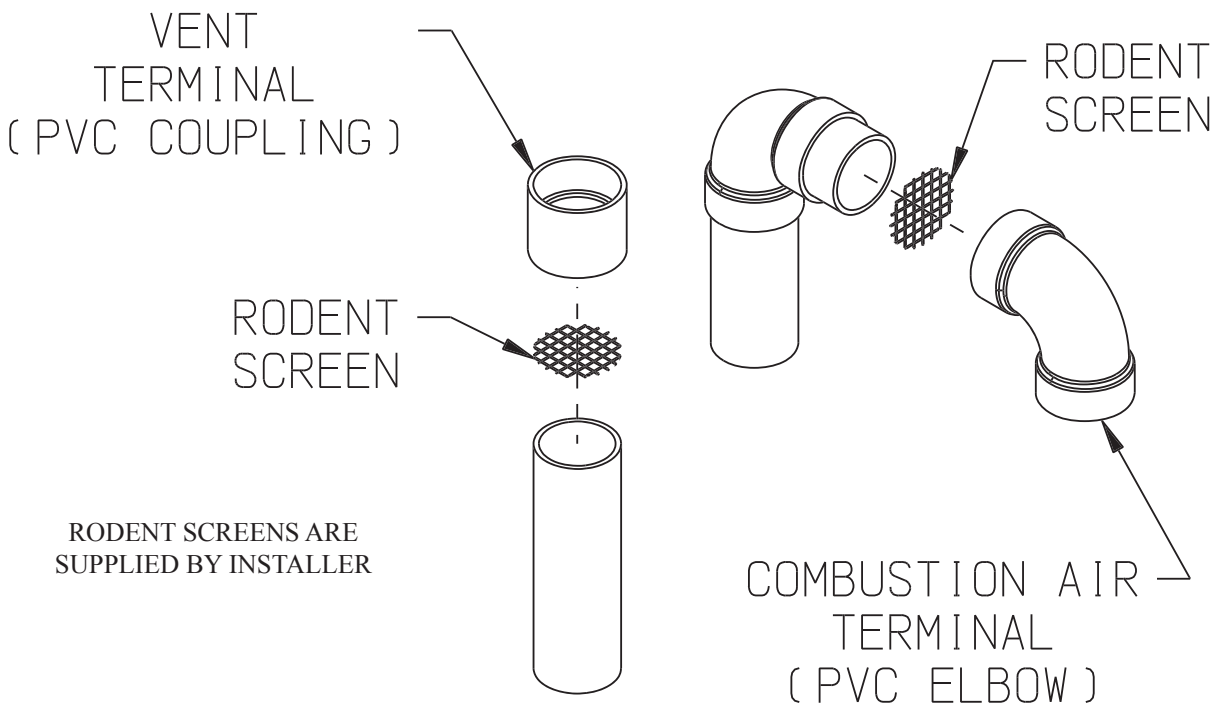

FIGURE 7.19: INSTALLATION OF STANDARD VERTICAL TERMINALS

- b. Drill two 3-1/8 holes through the wall for the vent and intake pipes.
- c. Drill four 3/16 holes for the mounting screws.
- d. Install the vent and intake pipe sections passing through the wall. Cut the pipes so that they protrude the following distances from the surface on which the vent plate will be mounted:
 - Vent: Between 1-3/4 and 2-1/4"
 - Intake: Between 1/4 and 1"
- e. Seal pipe penetrations in wall with RTV (silicone sealant).
- f. Mount the vent plate using the #8 x 2" screws and anchors provided with this kit.
- g. Seal the vent plate to the wall with RTV.
- h. Apply a bead of RTV around the OD of the vent pipe near its end.
- i. Slide the vent cap over the vent pipe and secure to the wall plate with the #8 x 2" screws provided.

7. Installation of IPEX FGV or Diversitech CVENT Concentric Vent Terminal (Terminal Options D,E,I & J) - This terminal may be used for either horizontal or vertical venting. See Figure 7.23 for horizontal installation or Figure 7.24 for vertical installation. When PVC is used for venting, a 30" CPVC straight section and CPVC elbow must be used prior to connection of the vent system to this terminal. If the vent system is too short to permit this, use the IPEX FGV CPVC terminal:

- a. For horizontal installations at the planned location cut a round hole in the exterior wall 1/2" larger than the "C" dimension indicated on Figure 7.22 for the size terminal being used. (See Part VII-B of this manual for permitted terminal locations).
- b. For vertical installations, cut a hole in the roof large enough to clear the concentric terminal at the location of the terminal (see Part VII-C of this manual for permitted terminal locations).
- c. If desired, the terminal can be shortened. See Figure 7.22 for specific information on making the terminal kit shorter based on the kit size being used. Cut the pipe squarely and de-burr both the OD and ID of the cut edges.
- d. Cement the inner pipe section of PVC pipe supplied with this kit to the Wye fitting using a primer and cement listed for use with PVC.



WARNING

- **Asphyxiation Hazard. CPVC/PVC vent piping and fittings rely on glued joints for proper sealing. Follow all manufacturer instructions and warnings when preparing pipe ends for joining and using the primer and the cement.**
- **When PVC is used with the concentric vent kit, the 30" CPVC straight section and elbow must be used prior to connection of the vent system to this terminal. If the vent system is too short to permit this, use an IPEX FGV CPVC terminal.**
- **Do not operate boiler without the rain cap in place.**
- **Method of securing and sealing terminals to the outside wall must not restrain the expansion of vent pipe.**

- e. Cement the outer pipe to the Wye, being careful, to keep the inner and outer pipes concentric.
- f. Slip the partially assembled terminal through the wall or ceiling from the inside and for horizontal installations orient so that the side outlet on the Wye is on or above the horizontal plane.
- g. For horizontal installations, seal the gap between the OD of the "outer pipe" and the exterior side of the wall with RTV sealant.
- h. Cement the rain cap onto the inner pipe. If desired, the rain cap can be attached to the inner pipe with the supplied stainless steel screw and nut so that it can be later removed for cleaning and inspection. If this is done, drill a 3/16" clearance hole in the rain cap and inner pipe in the location shown on Figure 7.22 for the size terminal kit being used and affix screw and nut. Do not overtighten. A field supplied rodent screen may also be installed on the end of the rain cap.
- i. For vertical installations, use a roof flashing and storm collar to prevent moisture from entering the building. Seal the roof flashing to the roof using generally accepted practice for the type of roof on the installation. Install the storm collar after verifying that the bottom of the rain cap will be at least 12" above the normal snow line. Apply RTV to seal the storm collars to the terminal.

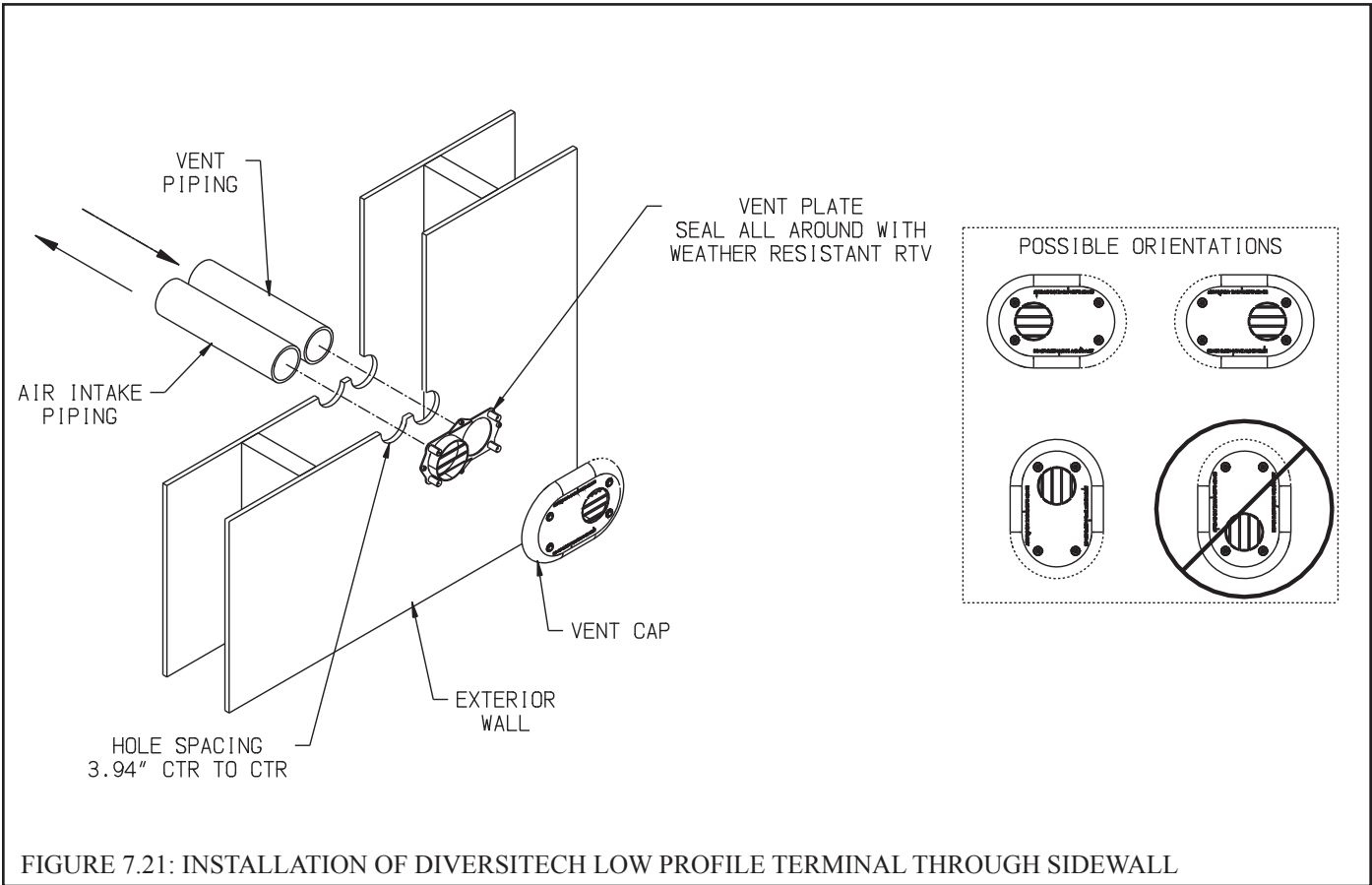
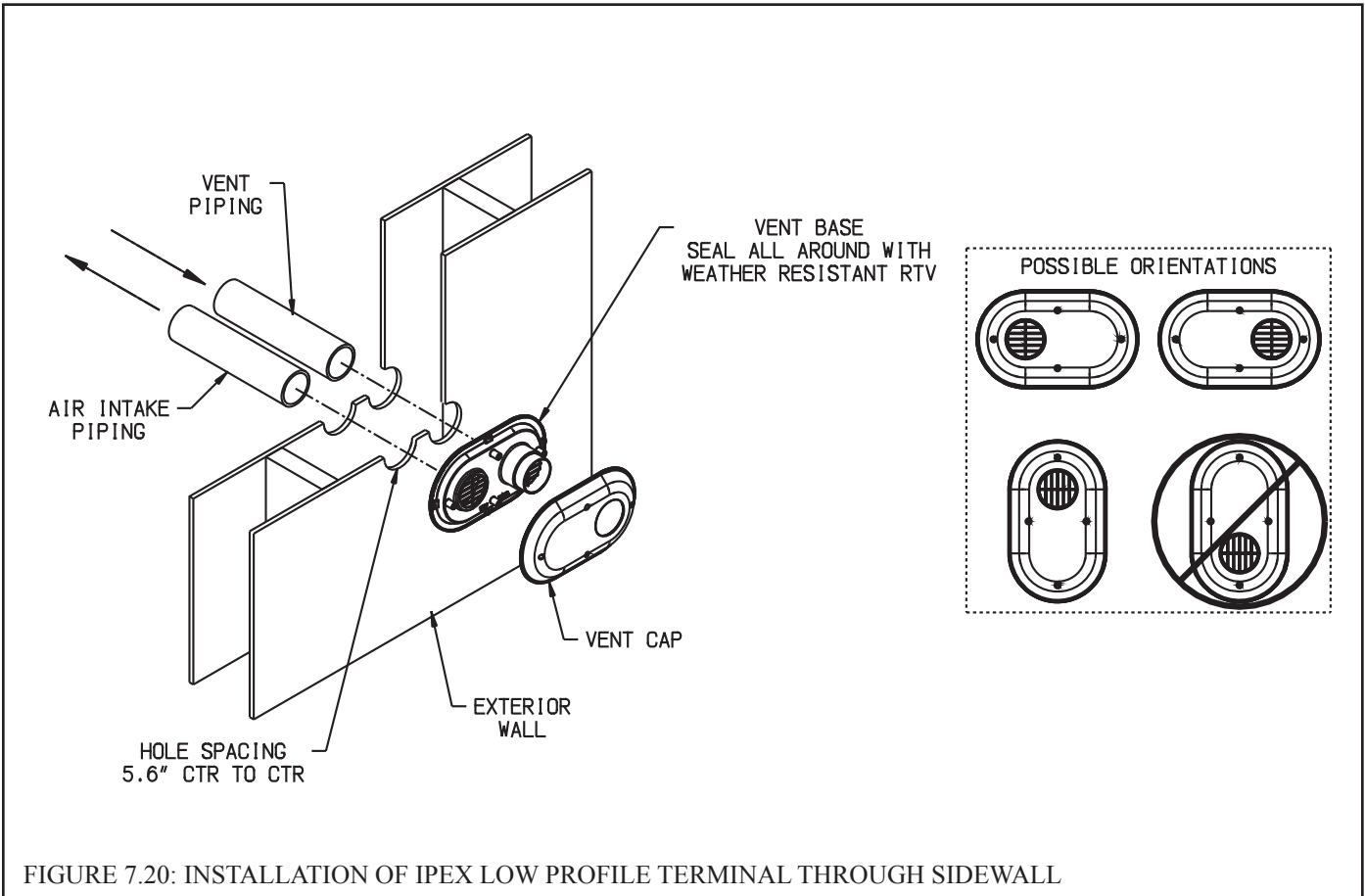

*OVERALL LENGTH OF INNER PIPE TO BE 'A' INCHES LONGER THAN OVERALL LENGTH OF OUTER PIPE.

KIT SIZE	*' A'	' B'	' C'	MANUFACTURER
2"	7-3/8"	1-3/4"	3-1/2"	IPEX
2"	12-3/16"	3/4"	3-1/2"	DIVERSITECH
3"	8-3/4"	2-1/4"	4-1/2"	IPEX
3"	13-3/16"	1"	4-1/2"	DIVERSITECH

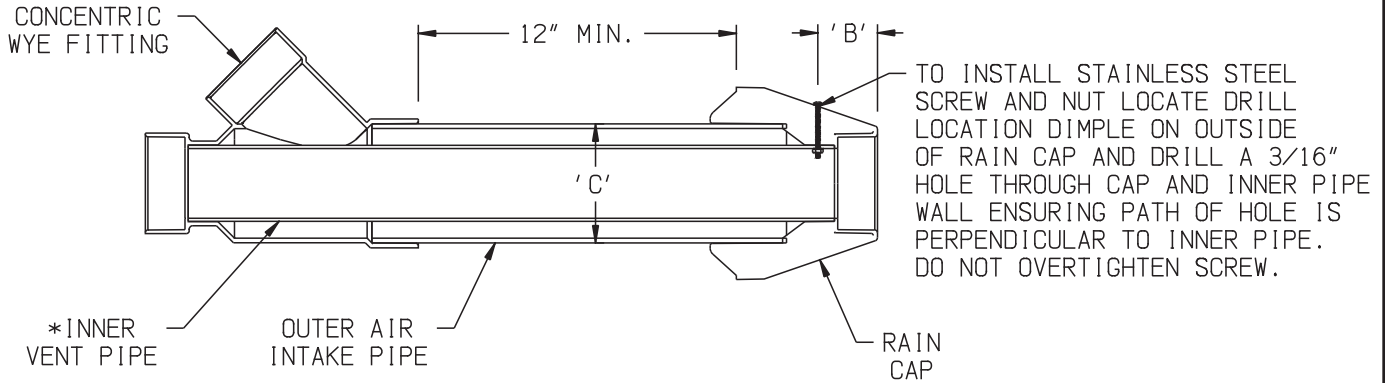

- NOTES: 1. ALL CUTS MUST BE SQUARE AND DEBURRED.
 2. LENGTHENING OF TERMINAL IS NOT PERMITTED.

FIGURE 7.22: CUTTING IPEX AND DIVERSITECH CONCENTRIC VENT TERMINALS

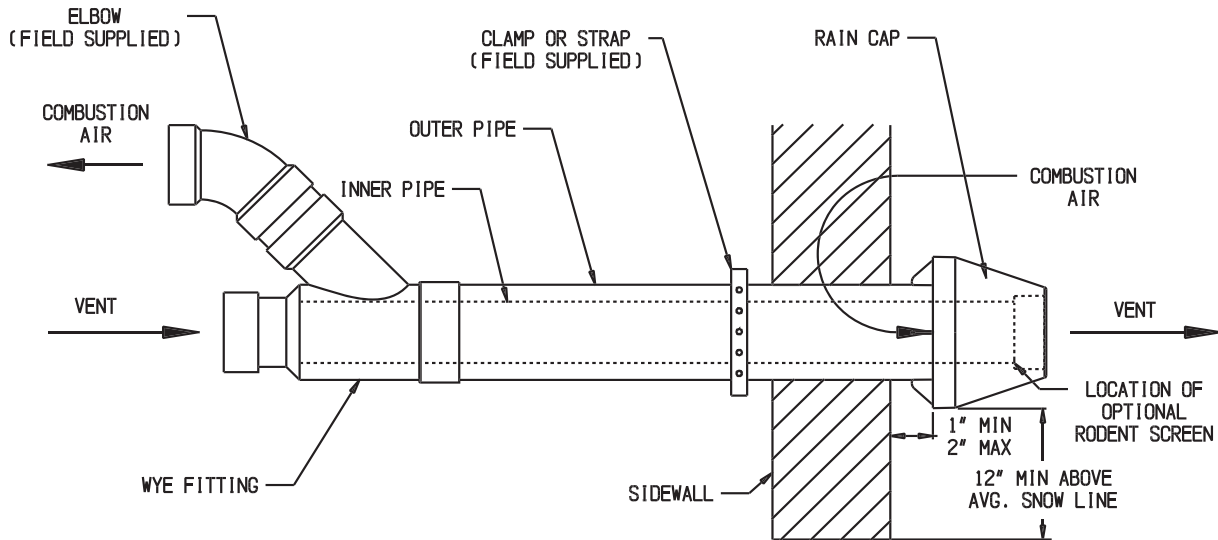

FIGURE 7.23: INSTALLATION OF IPEX AND DIVERSITECH CONCENTRIC TERMINAL THROUGH SIDEWALL

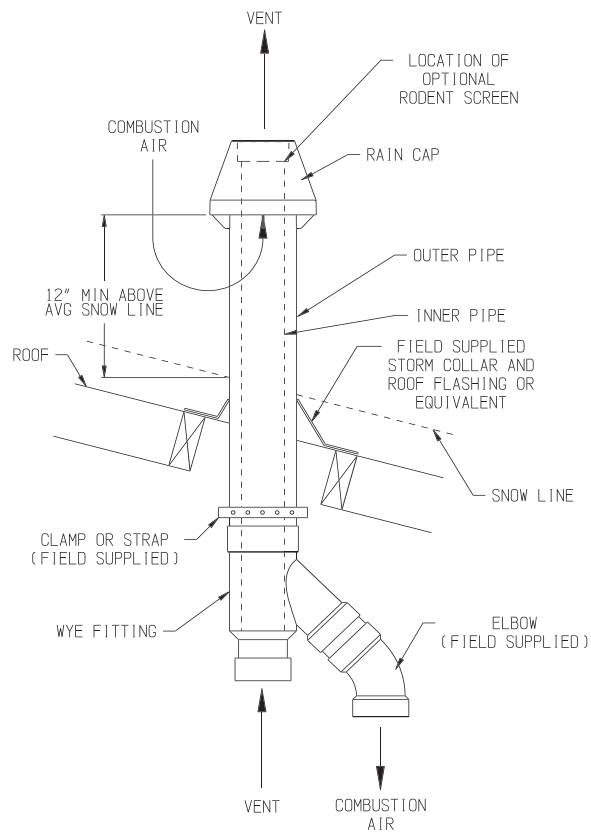

FIGURE 7.24: INSTALLATION OF IPEX AND DIVERSITECH CONCENTRIC TERMINAL THROUGH ROOF

F. Condensate Trap and Drain Line

All condensate which forms in the boiler or vent system passes through the heat exchanger and out of a bottom drain port which is connected to the condensate trap with a hose. This trap allows condensate to drain from the heat exchanger while retaining flue gases in the boiler. This trap is an integral part of the boiler but must be connected to a drain pipe as shown in Figure 7.25. A length of corrugated tubing is supplied with the boiler and is connected to the trap as shown in Figure 7.25. Note the following when disposing of the condensate:

1. If the corrugated condensate drain line must be extended, construct the extension from PVC or CPVC pipe. Insert the hose provided with the boiler into the end of the extension as shown in Figure 7.25.
2. Condensate is acidic. Do not use metallic pipe or fittings in the condensate drain line. Do not route the drain line through areas that could be damaged by leaking condensate.
3. Some jurisdictions may require that the condensate be neutralized before being disposed of. Dispose of condensate in accordance with local codes.
4. Do not route, or terminate, the condensate drain line in areas subjected to freezing temperatures.
5. If the point of condensate disposal is above the trap, it will be necessary to use a condensate pump to move the condensate to the drain. In such cases, select a condensate pump that is approved for use with condensing boilers. If overflow from this pump would result in property damage, select a pump with an overflow switch and use this switch to shut down the boiler. Alternatively, if heat is a necessity, use the overflow switch to trigger an alarm.
6. Do not attempt to move the trap from the location shown in Figure 7.25. Do not attempt to substitute another trap for the one provided with the boiler.
7. The vent shown in Figure 7.25 must be left open for the trap to work properly.



WARNING

Asphyxiation Hazard. Failure to install the condensate drain in accordance with the above instructions could cause flue gas to enter the building, resulting in personal injury or death.

NOTICE

- **Boiler condensate is corrosive. Route condensate drain line in a manner such that any condensate leakage will not cause property damage.**
- **Some jurisdictions may require that condensate be neutralized prior to disposal.**
- **Use materials approved by the authority having jurisdiction.**

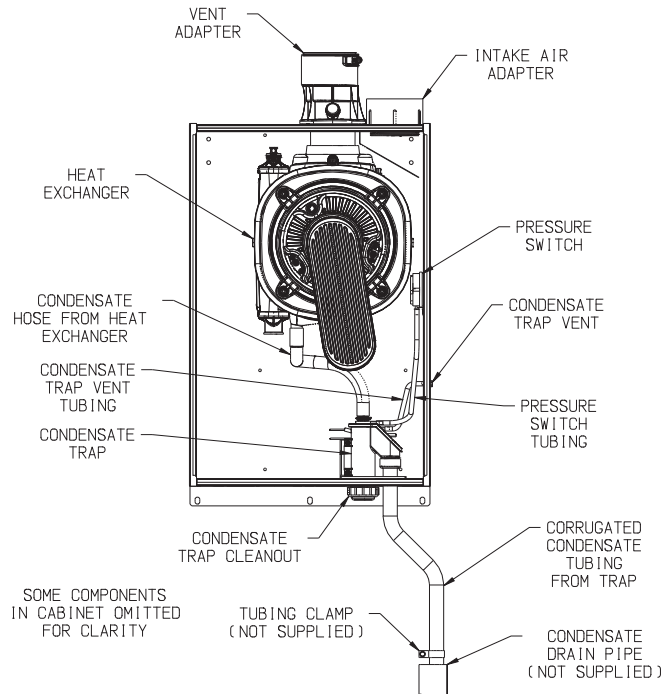

FIGURE 7.25: CONDENSATE PIPING ARRANGEMENT

G. Removing an Existing Boiler From a Common Chimney

This section only applies if this boiler is replacing an existing boiler that is being removed from a common chimney.

In some cases, when an existing boiler is removed from a common chimney, the common venting system may be too large for the remaining appliances. At the time of removal of an existing boiler, the following steps shall be followed with each appliance remaining connected to the common venting system placed in operation, while the other appliances remaining connected to the common venting system are not in operation.

- (a) Seal any unused openings in the common venting system.
- (b) Visually inspect the venting system for proper size and horizontal pitch and determine there is no blockage or restriction, leakage, corrosion and other deficiencies which could cause an unsafe condition.
- (c) Insofar as practical, close all building doors and windows and all doors between the space in which all the appliances remaining connected to the common venting system are located and other spaces of the building. Turn on clothes dryers and any appliance not connected to the common venting system. Turn on any exhaust fans, such as range hoods and bathroom exhausts, so they will operate at maximum speed. Do not operate a summer exhaust fan. Close fireplace dampers.
- (d) Place in operation the appliance being inspected. Follow the lighting instructions. Adjust thermostat so the appliance will operate continuously.
- (e) Test for spillage at the draft hood relief opening after 5 minutes of main burner operation. Use the flame of a match or candle, or smoke from a cigarette, cigar, or pipe.
- (f) After it has been determined that each appliance remaining connected to the common venting system properly vents when tested as outlined above, return doors, windows, exhaust fans, fireplace dampers and any other gas-burning appliances to their previous condition of use.
- (g) Any improper operation of the common venting system should be corrected so the installation conforms with the National Fuel Gas Code, ANSI Z223.1. When re-sizing any portion of the common venting system, the common venting system should be re sized to approach the minimum size as determined using the appropriate tables in Part 11 of the National Fuel Gas Code, ANSI Z223.1.



WARNING

Never common vent this boiler with other appliances.

Au moment du retrait d'une chaudière existante, les mesures suivantes doivent être prises pour chaque appareil toujours raccordé au système d'évacuation commun et qui fonctionne alors que d'autres appareils toujours raccordés au système d'évacuation ne fonctionnent pas:

- (a) Sceller toutes les ouvertures non utilisées du système d'évacuation.
- (b) Inspecter de façon visuelle le système d'évacuation pour déterminer la grosseur et l'inclinaison horizontale qui conviennent et s'assurer que le système est exempt d'obstruction, d'étranglement, de fuite, de corrosion et autres défaillances qui pourraient présenter des risques.
- (c) Dans la mesure du possible, fermer toutes les portes et les fenêtres du bâtiment et toutes les portes entre l'espace où les appareils toujours raccordés au système d'évacuation sont installés et les autres espaces du bâtiment. Mettre en marche les sècheuses, tous les appareils non raccordés au système d'évacuation commun et tous les ventilateurs d'extraction comme les hottes de cuisinière et les ventilateurs des salles de bain. S'assurer que ces ventilateurs fonctionnent à la vitesse maximale. Ne pas faire fonctionner les ventilateurs d'été. Fermer les registres des cheminées.
- (d) Mettre l'appareil inspecté en marche. Suivre les instructions d'allumage. Régler le thermostat de façon que l'appareil fonctionne de façon continue.
- (e) Faire fonctionner le brûleur principal pendant 5 min ensuite, déterminer si le coupe-tirage déborde à l'ouverture de décharge. Utiliser la flamme d'une allumette ou d'une chandelle ou la fumée d'une cigarette, d'un cigare ou d'une pipe.
- (f) Une fois qu'il a été déterminé, selon la méthode indiquée ci-dessus, que chaque appareil raccordé au système d'évacuation est mis à l'air libre de façon adéquate. Remettre les portes et les fenêtres, les ventilateurs, les registres de cheminées et les appareils au gaz à leur position originale.
- (g) Tout mauvais fonctionnement du système d'évacuation commun devrait être corrigé de façon que l'installation soit conforme au National Fuel Gas Code, ANSI Z223.1/NFPA 54 et (ou) aux codes d'installation CAN/CSA-B149.1. Si la grosseur d'une section du système d'évacuation doit être modifiée, le système devrait être modifié pour respecter les valeurs minimales des tableaux pertinents de l'appendice F du National Fuel Gas Code, ANSI Z223.1/NFPA 54 et (ou) des codes d'installation CAN/CSA-B149.1.

VIII Gas Piping



WARNING

Explosion Hazard. Failure to properly pipe gas supply to boiler may result in improper operation or leaks of flammable gas.

- **Gas supply to boiler and system must be absolutely shut off prior to installing or servicing boiler gas piping.**
- **Always assure gas piping is absolutely leak free and of the proper size and type for the connected load.**
- **Use a thread compound compatible with liquefied petroleum gas. Failure to use proper thread compounds on all gas connectors may result in leaks of flammable gas.**
- **If inlet pressure is above 1/2 psig (3.4 kPa) an additional gas pressure regulator is required. Consult gas supplier.**
- **Size corrugated stainless steel tubing (CSST) to ensure proper capacity and minimize flow restrictions.**

Gas piping to the boiler must be sized to deliver adequate gas for the boiler to fire at the nameplate input at an inlet pressure between the minimum and maximum values shown in Table 8.2. When sizing, also consider other existing and expected future gas utilization equipment (i.e. water heater, cooking equipment). For more information on gas line sizing, consult the utility or the *National Fuel Gas Code*, NFPA54/ANSI Z223.1, and/or CAN/CSA B149.1 *Natural Gas and Propane Installation Code*.

Figure 8.1 shows typical gas piping connection to the boiler. The 1/2" ground joint union must be the first fitting connected to the boiler and must be installed nut side down. A sediment trap must be installed upstream of all gas controls. Install a manual shut-off valve outside the jacket with a ground joint union as shown. All above ground gas piping upstream from manual shut-off valve must be electrically continuous and bonded to a grounding electrode. Refer to *National Electrical Code*, NFPA 70.

The boiler and its gas connection must be leak tested before placing the boiler in operation. When doing this, the boiler and its individual shut-off must be disconnected from the rest of the system during any pressure testing of that system at pressures in excess of 1/2 psi (3.5kPa). When pressure testing the gas system at pressures of 1/2 psi (3.5kPa) or less, isolate the boiler from the gas supply system by closing its individual manual shut-off valve. Locate leaks using approved combustible gas non-corrosive leak detector solution.



DANGER

Explosion Hazard. Do not use matches, candles, open flames or other ignition source to check for leaks.



WARNING

If gas pressure in the building is above 1/2 psig (3.4 kPa), an additional gas pressure regulator is required. Using one additional regulator for multiple gas appliances may result in unsafe operation. The additional regulator must be able to properly regulate gas pressure at the input of the smallest appliance. If the regulator can not do this, two or more additional regulators are required. Consult regulator manufacturer and/or local gas supplier for instructions and equipment ratings.



CAUTION

- Support the weight of the gas line piping independently from the boiler gas connection fitting located on the bottom of the boiler.
- If an additional regulator is used to reduce boiler inlet pressure below 1/2 psig (3.4 kPa) it must be at least 6 to 10 feet upstream of the boiler.
- It is very important that the gas line is properly purged by the gas supplier or utility company.

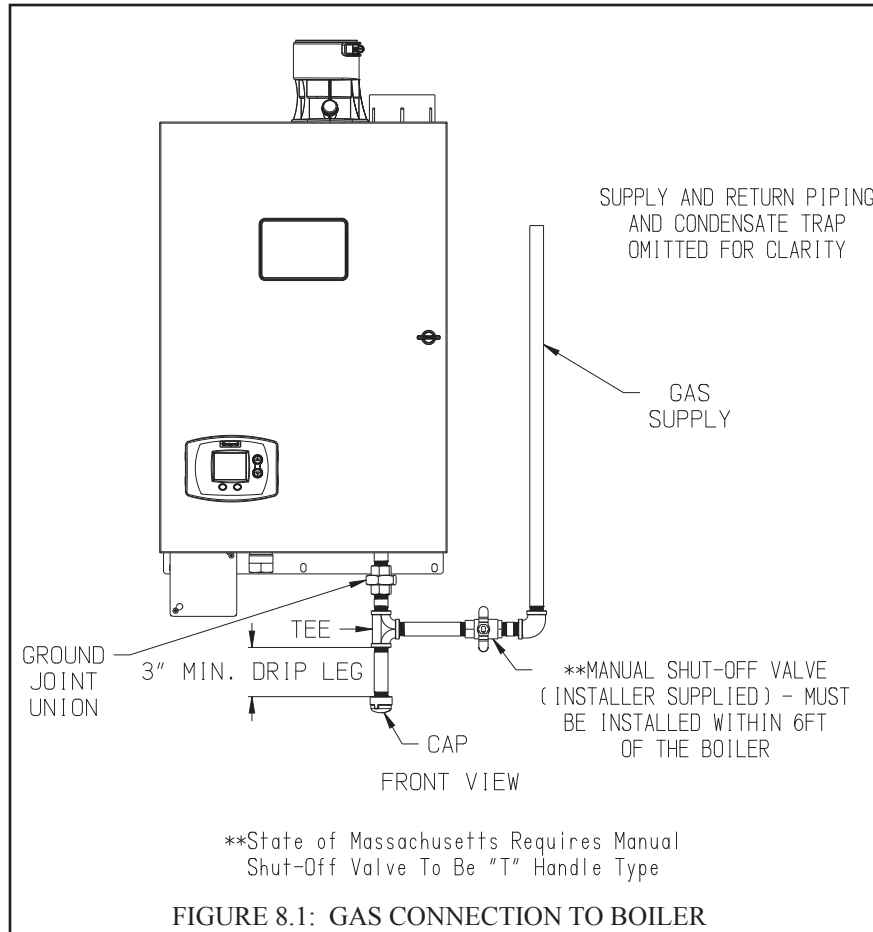

NOTICE

Install 1/2" ground joint union (nut side down) as shown in Figure 8.1. Failure to do so will make it difficult or impossible to remove burner for servicing.

TABLE 8.2: MINIMUM AND MAXIMUM INLET PRESSURES

MODEL	MAX (NATURAL & LP)	MIN (NATURAL)	MIN (LP)
80MBH	14.0"	2.5"	11.0"
100MBH	14.0"	2.5"	11.0"
120MBH	14.0"	2.5"	11.0"
150MBH	14.0"	2.5"	11.0"
180MBH	14.0"	2.5"	11.0"

IX System Piping

A. General System Piping Precautions



WARNING

- **Failure to properly pipe boiler may result in improper operation and damage to boiler or structure.**
- **Install boiler so that the gas ignition system components are protected from water (dripping, spraying, rain, etc.) during boiler operation and service (circulator replacement, etc.).**
- **Oxygen contamination of boiler water will cause corrosion of iron and steel boiler components and can lead to boiler failure. Warranty does not cover problems caused by oxygen contamination of boiler water or scale (lime) build-up caused by frequent addition of water.**

WATER QUALITY AND BOILER WATER ADDITIVES IMPORTANT NOTE

The heat exchanger used in this boiler is made from stainless steel coils having relatively narrow waterways. Once filled with system water, it will be subjected to the effects of corrosion, as well as fouling from any debris introduced from the system. Take the following precautions to minimize the chance of severe heat exchanger damage caused by corrosion and/or overheating:

1 Flush the system before connecting the boiler - In a replacement installation, flushing the system will remove impurities, such as sediment, solder flux, metal shavings, and traces of old boiler additives. Even if the system is new, do not omit this step – new systems will contain flux and may even contain some of the other impurities listed above. Flush the system completely and repeat if necessary to completely remove these contaminants. If necessary, a cleaning agent may be used to assist in system cleaning. See Part XI (“Start-up and Check-out”) for recommended cleaners.

2. Make sure that the system is tight - This is the single most important guideline. Tap water contains dissolved oxygen which causes corrosion. In a tight system, this oxygen comes out of solution and is quickly removed from the system through the automatic air vent. The system then remains essentially free of oxygen. If the system is not tight, however, frequent additions of make-up water can expose the heat exchanger to oxygen on a continuous basis. In addition, frequent additions of hard make-up water can cause calcium deposits to collect in the heat exchanger, causing severe damage. To minimize additions of make-up water:

- Inspect the system thoroughly for leaks before placing it in service.
- If the system includes underground piping, or other piping in which a leak might go undetected, consider isolating the boiler from the system with a heat exchanger.
- Make sure that the expansion tank is properly sized and in good condition. If it is not, the relief valve may open frequently, resulting in regular additions of make-up water.
- If an automatic fill valve is installed, installation of a water meter in the fill line is strongly recommended so that routine additions of make-up water can be detected and their cause corrected.

3. Non-Metallic Tubing - Even if the system is tight, oxygen can be introduced into the system through some types of non-metallic tubing used in radiant or snow melt systems. Other nonmetallic tubing is equipped with an oxygen barrier to prevent migration of oxygen into the water. If the boiler is to be installed in a system containing non-metallic tubing without an oxygen barrier, it must be isolated from the boiler with a heat exchanger as shown in Figure 9.10.

4. Water Chemistry, Antifreeze, and Boiler Water Additives – Improper boiler water chemistry can cause the heat exchanger damage described above, as well as deterioration of seals. Observe the water chemistry requirements shown in Part XI (“Start-up and Check-out”).

B. Near Boiler Piping Design

Proper operation of this boiler requires that the water flow rate through it remain within the limits shown in Table 9.1 any time the boiler is firing. At flow rates below the minimum shown, the boiler's flow switch and/or temperature rise limit function may prevent the boiler from firing. Flow rates through the boiler in excess of the maximum shown in Table 9.1 can result in excessive noise or erosion damage to piping.

Use of primary-secondary piping (described below) is strongly recommended for connection of the boiler to the system. Additional information on hydronic system design can be found in the *I=B=R* Guide RHH published by the Air-Conditioning, Heating and Refrigeration Institute (AHRI).

Table 9.1: Flow Limitations

Model	Flow (GPM)	
	Minimum	Maximum
80MBH	5.0	13.3
100MBH	5.1	13.3
120MBH	6.2	13.3
150MBH	7.7	13.3
180MBH	9.3	13.3

Primary-secondary piping can be used in heat-only applications as shown in Figure 9.2 or with an indirect water heater as shown in Figure 9.3A or Figure 9.3B. In either system, the flow rate through the boiler ("secondary loop" or "boiler loop") is completely independent of the flow rate through the system ("primary loop"). Use the following guidelines to ensure that the boiler will have the required flow shown in Table 9.1 regardless of the flow in the heating system.

1) System Loop Piping - Size the system circulator and piping to obtain the design flow rate through the heating system as you would on any other heating system. All piping between the expansion tank and secondary connection tees must be at least 1". In order to keep the flow rates in the system and boiler loops independent of each other, provide at least 8 diameters of straight pipe upstream of the first tee and 4 diameters downstream of the second tee. Keep the distance between the expansion tank and the first secondary tee as short as practical.

2) Boiler Loop Piping – The boiler loop circulator is supplied by the installer. The circulators in Table 9.5 will provide the required boiler loop flow provided both of the following conditions are met:

- All piping in the boiler loop has a nominal size of at least 1"
- The equivalent length of all piping in the boiler loop is 60ft or less.

To verify that the 60ft, equivalent length is not exceeded, do the following:

- a) Count all fittings in the planned boiler loop (the shaded piping in Figure 9.6). In doing so, do not count the secondary connection tees, unions, or the fittings supplied with the boiler (these have already been accounted for).
- b) Using Table 9.4, find the equivalent lengths of all fittings in the boiler loop. Total these equivalent lengths and add them to the total length of planned straight pipe in the boiler loop.
- c) The result is the total equivalent length of the planned boiler loop. If the equivalent length calculated in (b) is under the limit shown in Table 9.5, the boiler pump will achieve a flow rate and temperature rise approximately equal to that shown in this table. Otherwise, the equivalent length must be reduced.

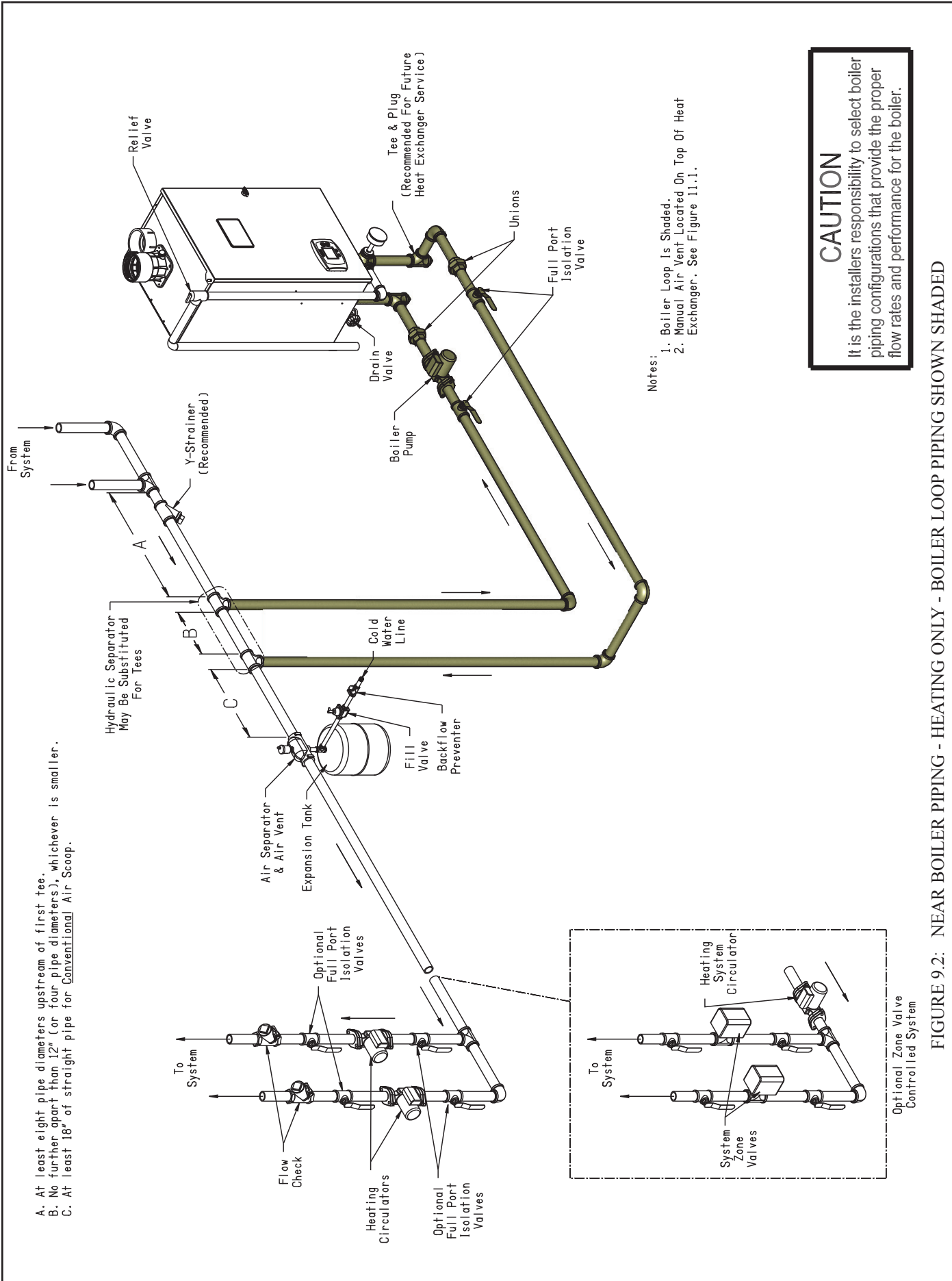

- A. At least eight pipe diameters upstream of first tee.
- B. No further apart than 12" (or four pipe diameters), whichever is smaller.
- C. At least 18" of straight pipe for Conventional Air Scoop.

Hydraulic Separator
May Be Substituted
For Tees

- Notes:
1. Boiler Loop Is Shaded.
 2. Manual Air Vent Located On Top Of Heat Exchanger. See Figure 11.1.

CAUTION
It is the installers responsibility to select boiler piping configurations that provide the proper flow rates and performance for the boiler.

FIGURE 9.2: NEAR BOILER PIPING - HEATING ONLY - BOILER LOOP PIPING SHOWN SHADED

- A. At least eight pipe diameters upstream of first tee.
- B. No further apart than 12" (or four pipe diameters), whichever is smaller.
- C. At least 18" of straight pipe for Conventional Air Scoop.

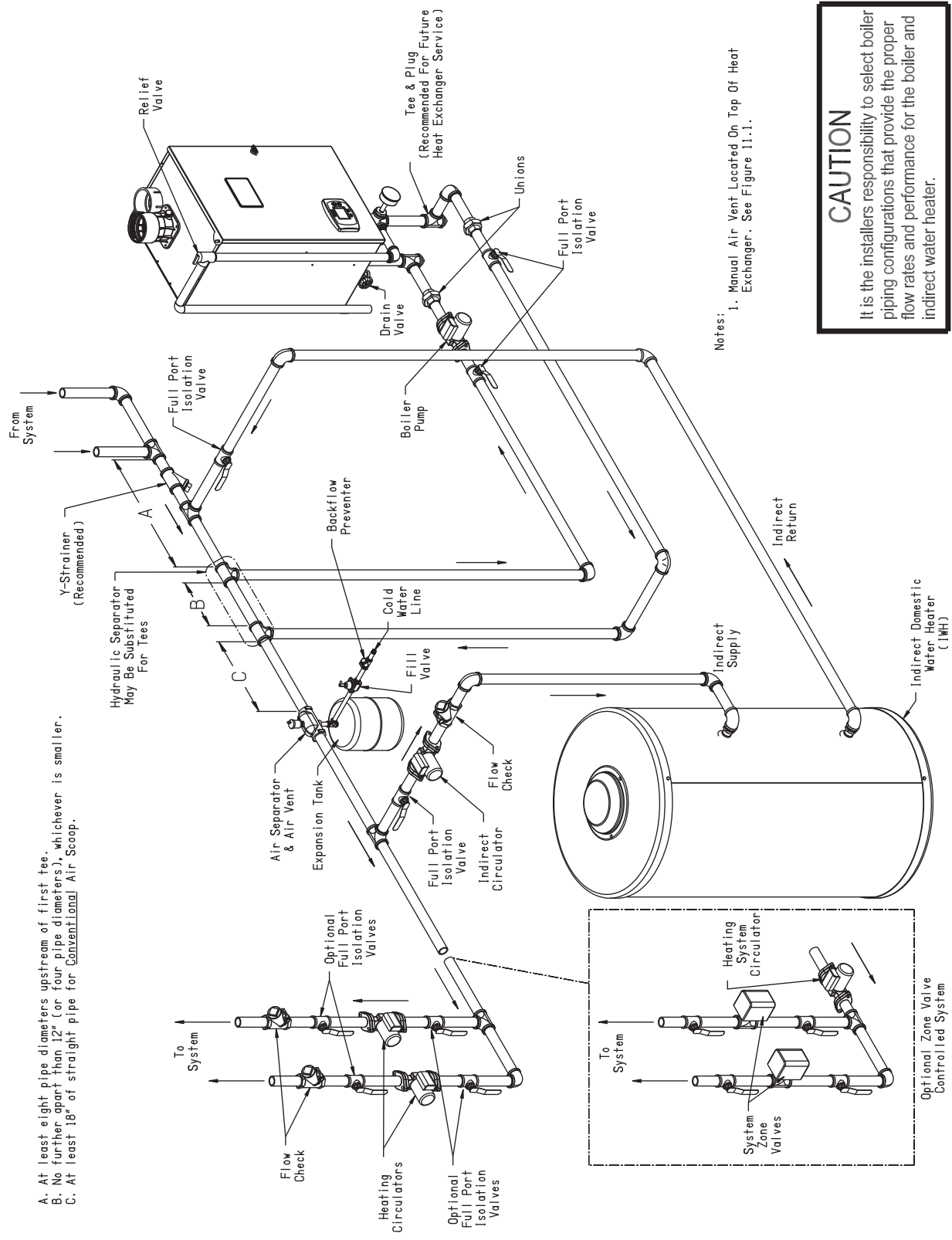

Notes:
 1. Manual Air Vent Located On Top Of Heat Exchanger. See Figure 11.1.

CAUTION
 It is the installers responsibility to select boiler piping configurations that provide the proper flow rates and performance for the boiler and indirect water heater.

FIGURE 9.3a: NEAR BOILER PIPING - HEATING PLUS INDIRECT WATER HEATER

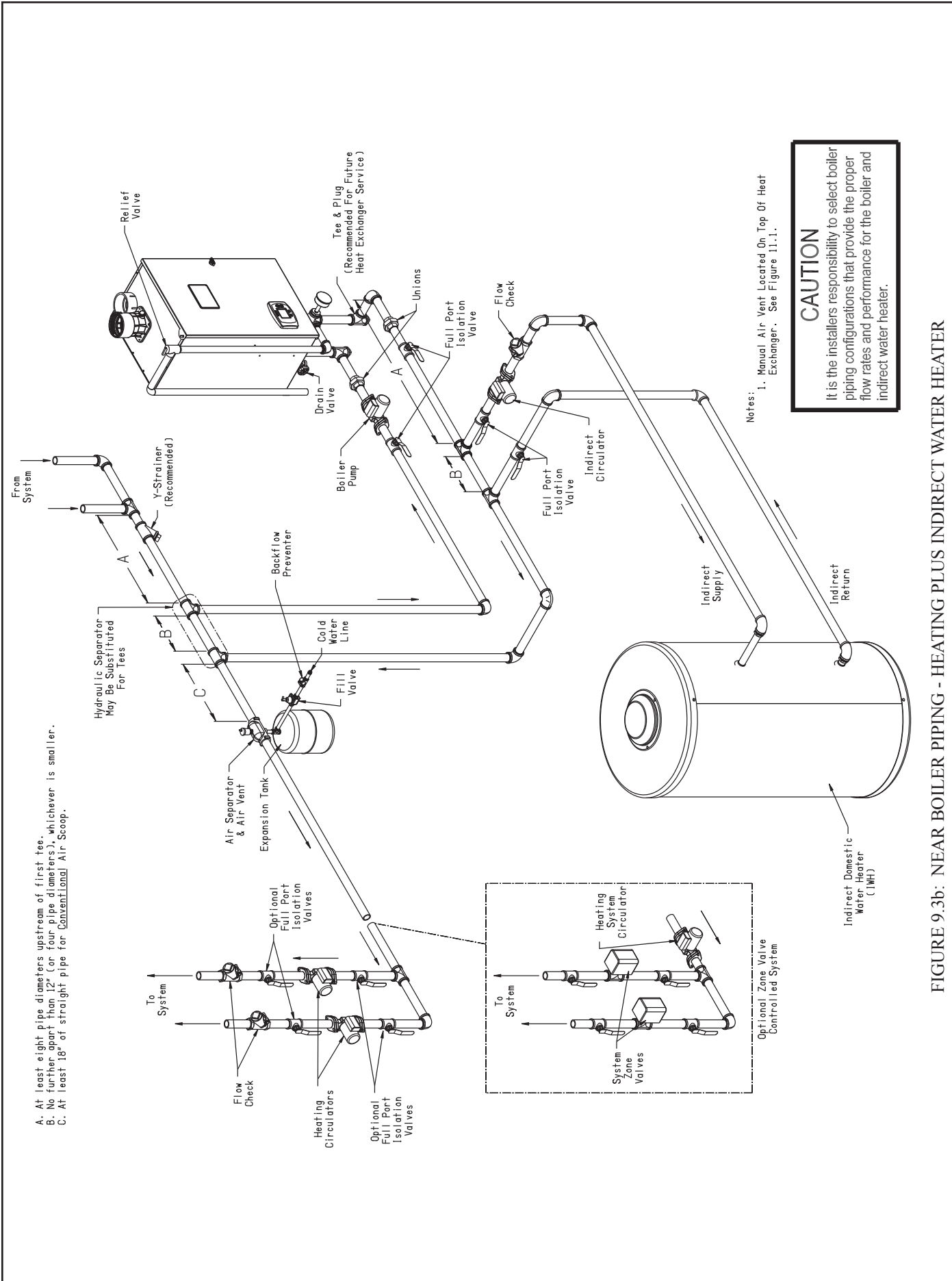

- A. At least eight pipe diameters upstream of first tee.
- B. No further apart than 12" (or four pipe diameters), whichever is smaller.
- C. At least 18" of straight pipe for Conventional Air Scoop.

CAUTION
 It is the installers responsibility to select boiler piping configurations that provide the proper flow rates and performance for the boiler and indirect water heater.

Notes:
 1. Manual Air Vent Located On Top Of Heat Exchanger. See Figure 11.1.

FIGURE 9.3b: NEAR BOILER PIPING - HEATING PLUS INDIRECT WATER HEATER

Example – A 120MBH model is to be connected to a heating system as shown in Figure 9.2. A total of 20 ft of straight pipe will be installed between the boiler and the system loop.

Count all fittings in the boiler loop (shaded in Figure 9.2):

4 90 Elbows

2 Turn in Tee (under boiler- primary-secondary tees not counted)

2 Isolation Valves

1 Y Strainer having a Cv of 30.

Note: Unions, Secondary Connection Tees, and factory supplied fittings are ignored.

Calculate total equivalent length from Table 9.4:

$$20\text{ft Straight Pipe} + 4 \text{ Elbows} \times 2.8 + 2 \text{ Turn in Tee} \times 5.5 + 2 \text{ Valves} \times 0.7 = 43.6 \text{ Equivalent Feet}$$

Since the total equivalent length is less than 60ft, flow through boiler loop meets requirements in Table 9.1

3) Indirect Water Heater Loop Piping – If an indirect water heater is used, install it as shown in Figures 9.3a or 9.3b. Refer to the indirect water heater installation manual for the proper sizing of the indirect water heater loop pump and piping.

4) Hydraulic Separators – Hydraulic separators serve the same purpose as the closely spaced tees connecting the boiler and system loops in Figure 9.1. They also generally provide effective connection points for automatic air elimination devices and an expansion tank. These separators are available from several sources and may be used in place of the closely spaced tees shown in Figures 9.2, 9.3a or 9.3b. When a hydraulic separator is used in place of the tees, the 60ft equivalent length limitation still applies. Select a hydraulic separator having 1” or larger boiler connections that is designed for the boiler flow rates shown in Table 9.1.

Table 9.4: Equivalent Lengths for Selected Valves and Fittings
(May Be Used for Copper or Threaded Fittings)

Fitting	Pipe Size	Equivalent Length (ft)
90° Elbow	1”	2.8
45° Elbow	1”	1.4
90° Turn in Tee	1”	5.5
Run of Tee	1”	1.8
Gate Valve (Open)	1”	0.7
Full Port Ball Valve	1”	0.7
Y-Strainer*	1”	7.0

* Based on Cv of 20. Pressure drop through strainers varies widely. 7ft equivalent length may be assumed for strainers having a published Cv greater than 20.

Table 9.5: Flow Available with Boiler Loop Equivalent Length of 60ft or Less*

Boiler Model	Approx. Flow (GPM)	Approx. Rise (°F)	Circulator Model	
			Taco	Grundfos
80MBH	6.4	23	009	26-64
100MBH	8.0	23	0013	26-99
120MBH	9.2	24	0013	26-99
150MBH	11.9	24	0013	26-99
180MBH	11.9	29	0013	26-99

* For multi-speed pumps, this table assumes pump is set to highest speed.

C: Standard Piping Installation Requirements

Observe the following requirements when installing the boiler piping:

- 1) Relief Valve (Required) – The relief valve is shipped loose and must be installed in the location shown in Figure 9.6, using the side outlet Tee and other fittings provided. ASME Section IV currently requires that this relief valve be installed above the heat exchanger as shown. Pipe the outlet of the relief valve to a location where water or steam will not create a hazard or cause property damage if the valve opens. The end of the discharge pipe must terminate in unthreaded pipe. If the relief valve discharge is not piped to a drain, it must terminate at least 6” above the floor. Do not run the discharge piping through an area that is prone to freezing. The termination of the relief valve must be in an area where it is not likely to become plugged by debris.

The relief valve supplied with the boiler is set to open at 30 psi. If it is replaced, the replacement must have a setting less than or equal to the maximum allowable working pressure (MAWP) shown on the ASME data plate.



Explosion / Scald Hazard

- Pipe relief valve discharge to a location where the potential of severe burns is eliminated.
- Do not install a relief valve having a setting greater than the MAWP shown on the rating plate.
- Do not install a valve in the relief valve discharge line.
- Do not install relief valve in a location other than that specified by the factory.
- Do not plug the relief valve discharge.

- 2) Gauge (Required) - Indicates supply water pressure and temperature. This gauge is shipped loose. Install it as shown in Figure 9.6.
- 3) Circulator (required) – The boiler loop circulator is supplied by the installer and must be sized to provide the required boiler flow rate. Usually at least one additional circulator will be required for the system to work properly. See the previous section for more information.
- 4) Expansion Tank (required) – If this boiler is replacing an existing boiler with no other changes in the system, the old expansion tank can generally be reused. If the expansion tank must be replaced, consult the expansion tank manufacturer’s literature for proper sizing.
- 5) Fill Valve (required) – Either a manual or automatic fill valve may be used, but a manual valve is preferred because it eliminates unmonitored additions of make-up water to the system. The ideal location for the fill valve is at the expansion tank.
- 6) Automatic Air Vent (required) – At least one automatic air vent is required. Manual air vents will usually be required in other parts of the system to remove air during initial fill.
- 7) Manual Reset High Limit (required by some codes) - This control is required by ASME CSD-1 and some other codes. Install the high limit in the boiler supply piping just above the boiler with no intervening valves. Set the manual reset high limit to 200°F. Wire the limit per Figure 10.3 in the Wiring section.
- 8) Isolation Valves (recommended) - Isolation valves are useful when the boiler must be drained, as they will eliminate having to drain and refill the entire system.
- 9) Strainer (recommended) – Install a Y Strainer, or other suitable strainer, to prevent any system debris from entering the boiler and fouling the water passages. Note that some strainers have a significant pressure drop, which may impact the ability of the boiler pump to obtain the required flow. See section B for additional information.
- 10) Drain Valve (required) – Install the drain valve supplied as shown in Figure 9.6.

- 11) Low Water Cut-off (may be required by local jurisdiction) – Protection of this boiler against low water and/or inadequate flow is provided by the UL353 certified flow switch built into the boiler. This is a water tube boiler and this flow switch is therefore the only effective way to provide such protection. Section HG614(c) of the 2015 ASME boiler and Pressure Vessel Code recognizes the use of a listed flow switch in lieu of a low water cut-off on water tube boilers.

In the event that a local jurisdiction insists upon the installation of a low water cut-off with this boiler, refer to Part X and the low-water cut-off manufacturer's instructions for proper wiring. Install the low water cut-off in the supply piping at the point prescribed by the local jurisdiction (generally at a point above the boiler).

If a probe type low water cut-off is used, be certain that it is located at a point in the piping from which air can escape to an automatic air vent. Generally, this means that there should be no down-turns in the piping between the low water cut-off and the point where the automatic air vent is installed. Failure to do this may result in nuisance boiler shut-downs due to small amounts of air trapped around the probe.

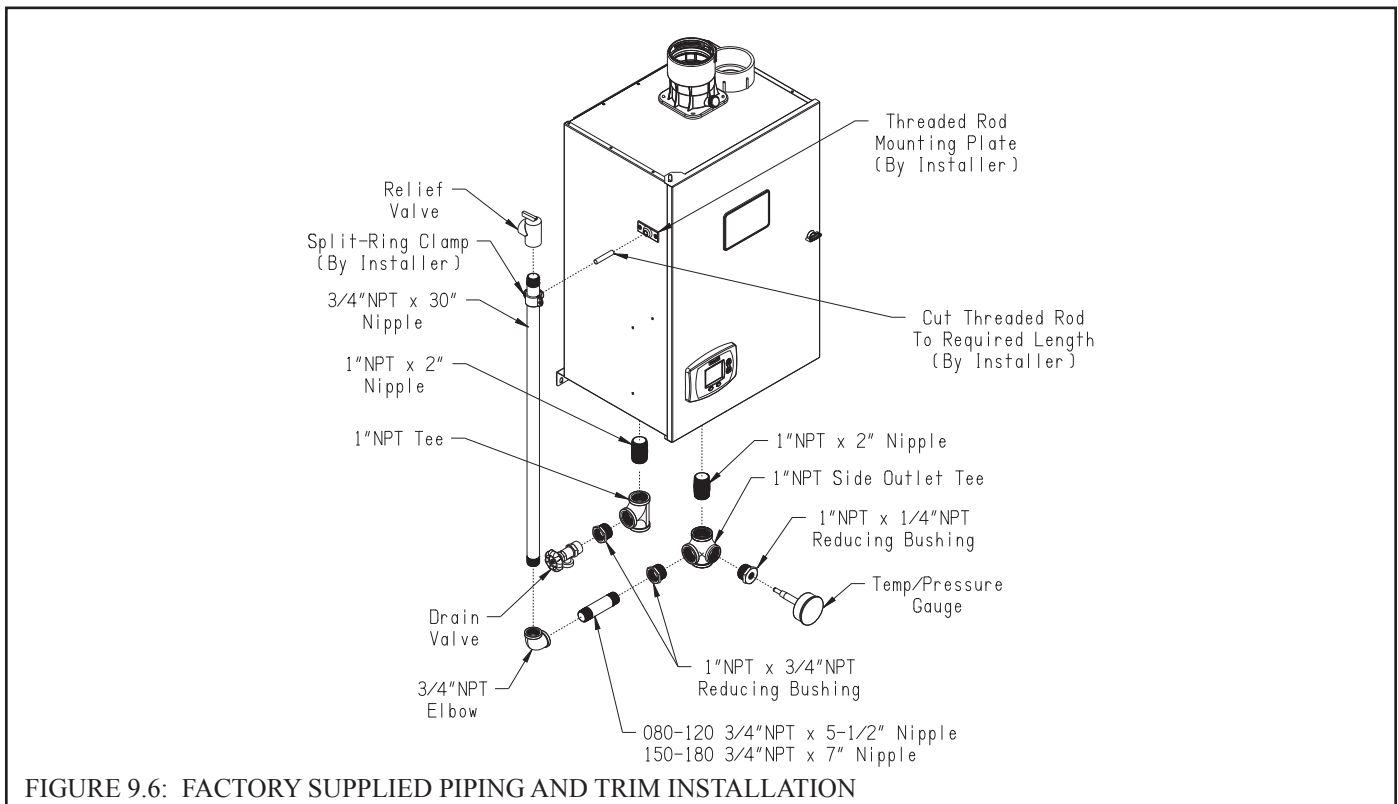

D. Piping for Special Situations

- 1) Systems containing oxygen - Many hydronic systems contain enough dissolved oxygen to cause severe corrosion damage to a this boiler. Some examples include:

- Radiant systems that employ tubing without an oxygen barrier.
- Systems with routine additions of fresh water.
- Systems which are open to the atmosphere.

If the boiler is to be used in such a system, it must be separated from the oxygenated water being heated with a plate heat exchanger. Consult the heat exchanger manufacturer for proper heat exchanger sizing as well as flow and temperature requirements. All components on the oxygenated side of the heat exchanger, such as the pump and expansion tank, must be designed for use in oxygenated water.

- 2) Piping with a Chiller - If the boiler is used in conjunction with a chiller, pipe the boiler and chiller in parallel. Use isolation valves to prevent chilled water from entering the boiler.

- 3) Air Handlers - Where the boiler is connected to air handlers through which refrigerated air passes, use flow control valves in the boiler piping or other automatic means to prevent gravity circulation during the cooling cycle.

This page is intentionally left blank.

X Wiring



DANGER

Electrical Shock Hazard. Positively assure all electrical connections are unpowered before attempting installation or service of electrical components or connections of the boiler or building. Lock out all electrical boxes with padlock once power is turned off.



WARNING

- All wiring and grounding must be done in accordance with the authority having jurisdiction or, in the absence of such requirements, with the National Electrical Code (NFPA 70). In Canada, all wiring and grounding must be done in accordance with the Canadian Electrical Code, Part 1 (CSA C22.1 - latest edition).
- Failure to properly wire electrical connections to the boiler may result in serious physical harm.
- Electrical power may be supplied from more than one circuit. Make sure all power is off before attempting any electrical work.
- Each boiler must be protected with a properly sized over-current device.
- Never jump out or make inoperative any safety or operating controls.
- The wiring diagrams contained in this manual are for reference purposes only. Each boiler is shipped with a wiring diagram attached to the front door. Refer to this diagram and the wiring diagram of any controls used with the boiler. Read, understand and follow all wiring instructions supplied with the controls.

NOTICE

This boiler is equipped with a listed high water temperature limit function. This limit provides boiler shutdown in the event the boiler water temperature exceeds the set point of the limit control. Certain Local Codes require an additional water temperature limit. If necessary, install an additional water temperature limit such as a Honeywell L4006 Aquastat. Wire as indicated in Figure 10.3.

Figure 10.1 shows the locations for making both high voltage and low voltage field connections.

- 1) Line Voltage (120 VAC) Field Connections – Leads for the line voltage connections are located in the junction box as shown in Figure 10.1. Provide a dedicated circuit for the boiler of 15A. A service switch is recommended and is required by many local codes. Locate this switch in accordance with local codes or, in the absence of any, in a location where it can be safely accessed in an emergency involving the boiler. All 120VAC connections to the boiler itself are wire nut connections, except for the ground, which is a screw. The leads are color coded as follows:

- 120VAC Hot - Black
- 120VAC Neutral - White
- Boiler Pump Hot - Red
- System Pump Hot - Yellow
- DHW Pump Hot - Blue

See Figure 10.2 for line voltage field connection wiring.

The use of the pump outputs are as follows:

- a) Boiler pump - Pumps water through the boiler. It is on whenever there is a call for CH or DHW.
- b) DHW Pump (“IWH Circulator”) - Pumps water directly through the indirect water heater.
- c) System Pump - Pumps water through the radiation. This pump is hydraulically separated from the boiler pump, either by closely spaced tees, or by a hydraulic separator. The system pump is always on when the system is responding to a call for CH.

Maximum combined current draw for all circulators is 6.3 FLA.

2) Low Voltage Connections – Low voltage field connections on the low voltage PCB are shown in Figure 10.3 and are listed from left to right:

- 1 Heat T’Stat - 24VAC heating thermostat
- 2 Heat T’Stat - 24VAC heating thermostat
- 3 DHW Stat - 24VAC domestic hot water thermostat (1)
- 4 DHW Stat - 24VAC domestic hot water thermostat (2)
- 5 External Limit - Field supplied low voltage safety limit contacts (1)
- 6 External Limit - Field supplied low voltage safety limit contacts (2)
- 7 Outdoor Sensor - Tasseron TSA00AA Outdoor Temperature Sensor (1)
- 8 Outdoor Sensor - Tasseron TSA00AA Outdoor Temperature Sensor (2)

External power must not be applied to any of the low voltage terminals - doing so may damage the boiler control. Also note the following:

- a) External Limit - The external limit terminals are intended for use with a field supplied safety device, such as a manual reset high limit or low-water cut-off. When an external limit is used, the jumper between these two terminals must be removed. Failure to remove this jumper will render the external safety devices ineffective.

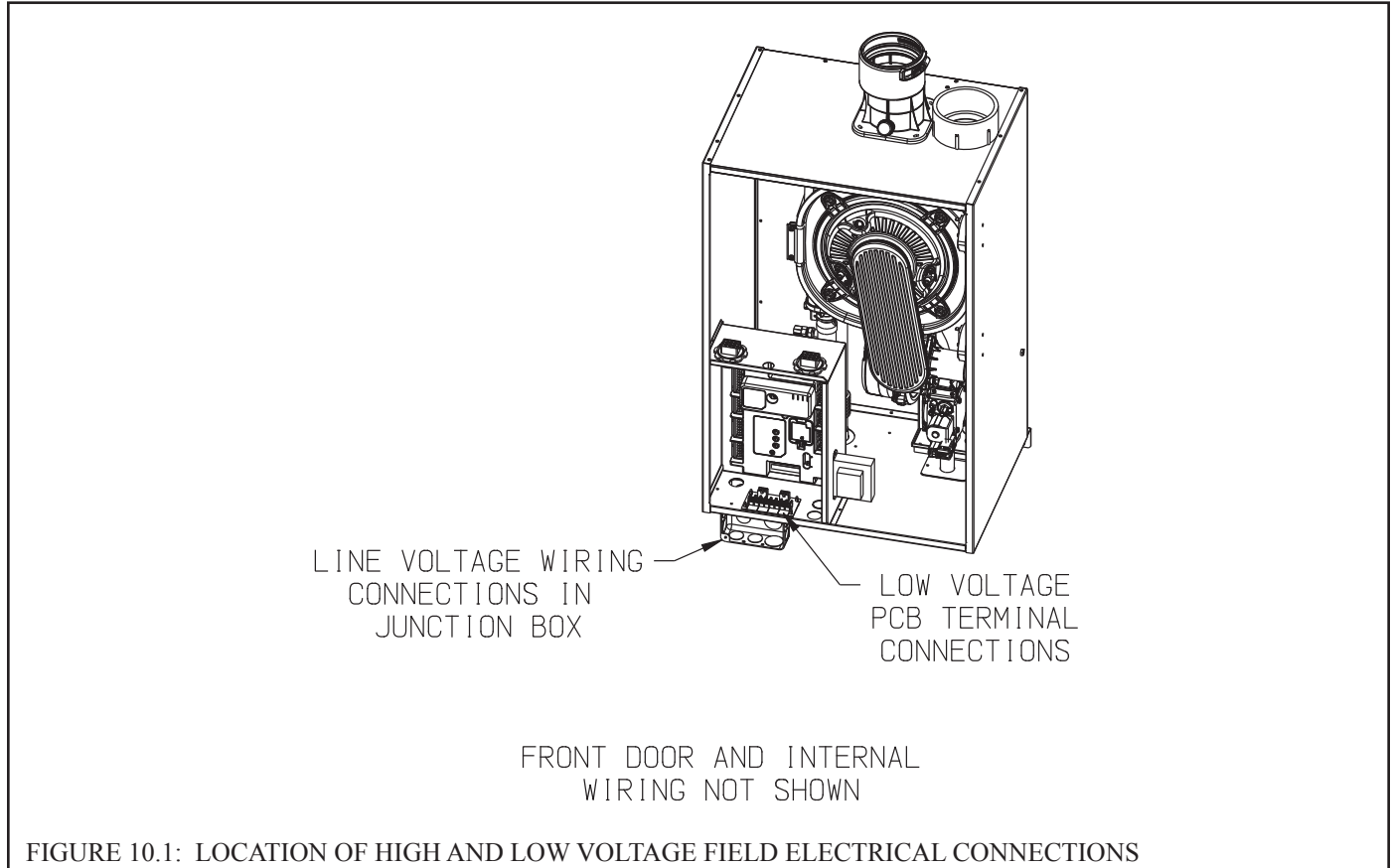

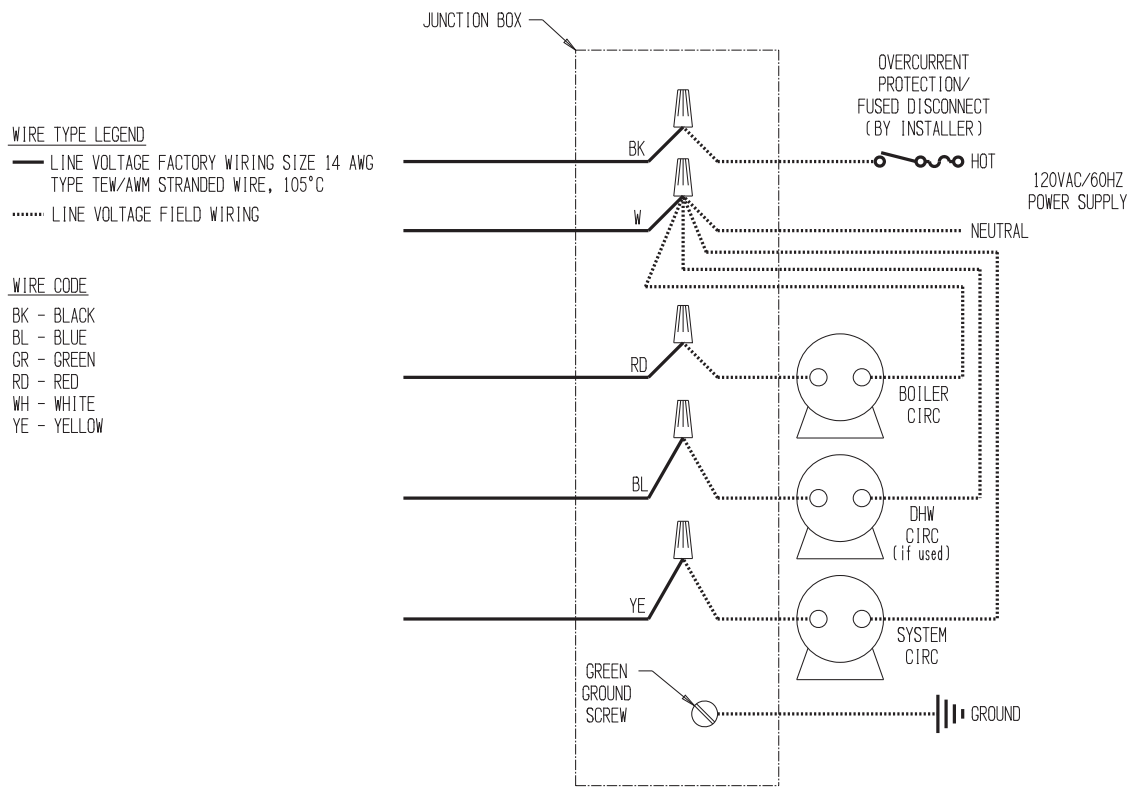

FIGURE 10.2: LINE VOLTAGE FIELD CONNECTIONS

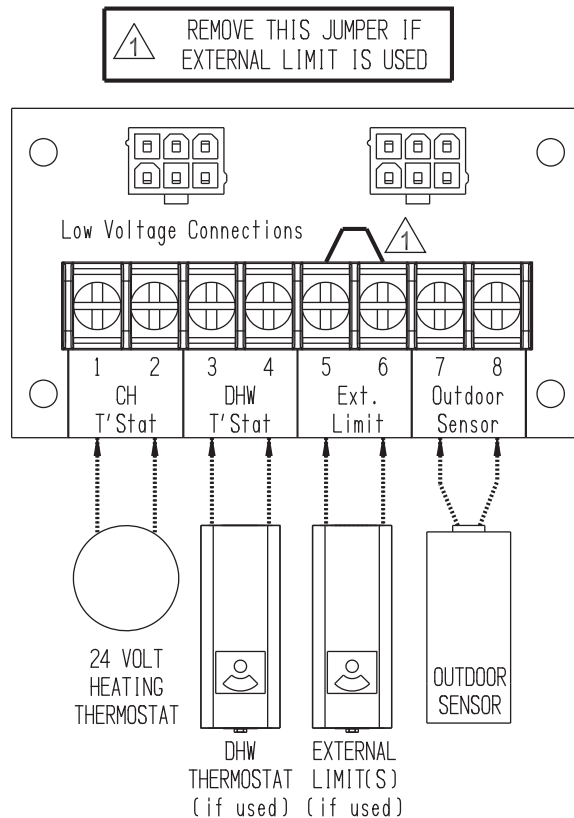

FIGURE 10.3: LOW VOLTAGE PCB TERMINAL CONNECTIONS

- b) Outdoor Sensor - Use only the Tasseron TSA00AA outdoor sensor supplied with the boiler. When this sensor is connected and enabled, the boiler will adjust the target supply water temperature downwards as the outdoor air temperature increases. This sensor should be located on the outside of the structure in an area where it will sense the average air temperature around the house. Avoid placing this sensor in areas where it may be covered with ice or snow. In general, locations where the sensor will pick up direct radiation from the sun should also be avoided. Avoid placing the sensor near potential sources of electrical noise such as transformers, power lines, and fluorescent lighting. Wire the sensor to the boiler using 22 gauge or larger wire. As with the sensor itself, the sensor wiring should be routed away from sources of electrical noise. Where it is impossible to avoid such noise sources, wire the sensor using a 2 conductor, UL Type CM, AWM Style 2092 shielded cable. Connect one end of the shielding on this cable to ground.
- c) Low water cut-off wiring – Although not necessary to protect this boiler (see Part IX), some jurisdictions may insist that a low water cut-off (LWCO) be installed with this boiler. There are two ways to wire a LWCO into this boiler:
- A 120V LWCO may be wired to break 120V power to the boiler (Figure 10.4a)
 - A 24V LWCO may be wired so that its contacts are wired to the external limit connections on the boiler. When this is done a separate transformer must be supplied by the installer to power the LWCO's sensing circuit. This transformer must be completely isolated from the boiler wiring (Fig 10.4b).



CAUTION

- **When making low voltage connections, make sure that no external power source is present in the thermostat or limit circuits. If such a power source is present, it could destroy the boiler's control. One example of an external power source that could be inadvertently connected to the low voltage connections is a transformer in the old thermostat wiring.**

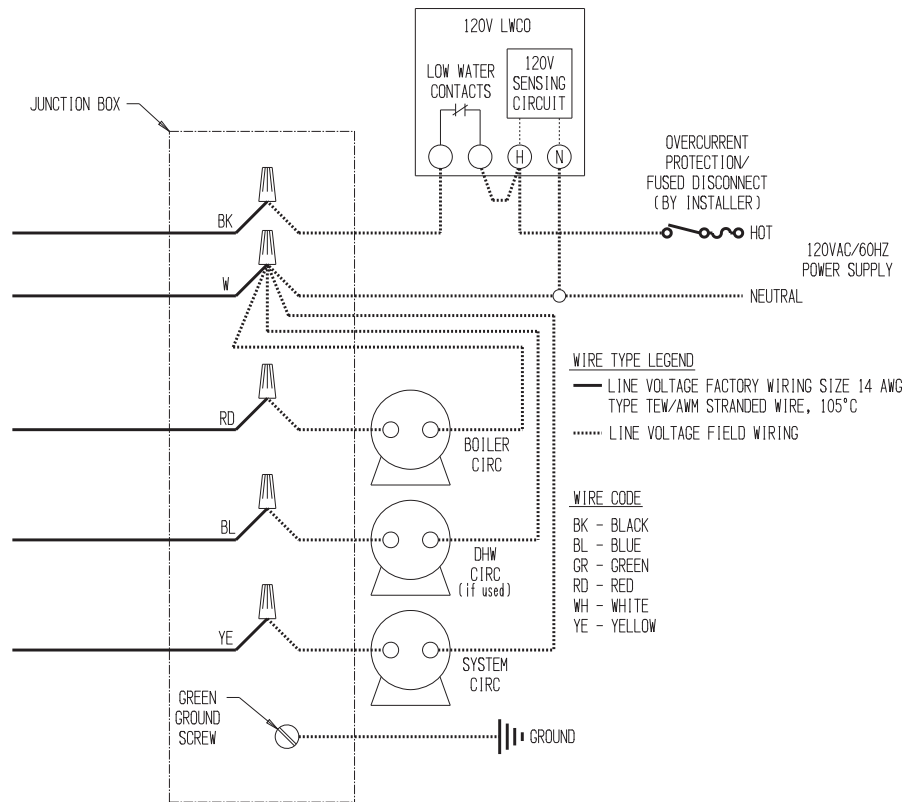

FIGURE 10.4a: 120V LWCO FIELD WIRING

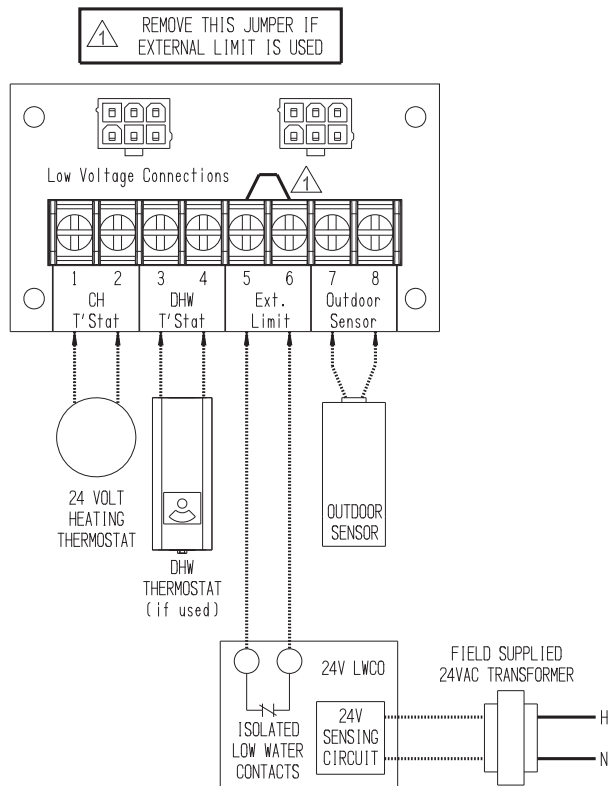

FIGURE 10.4b: 24V LWCO FIELD WIRING

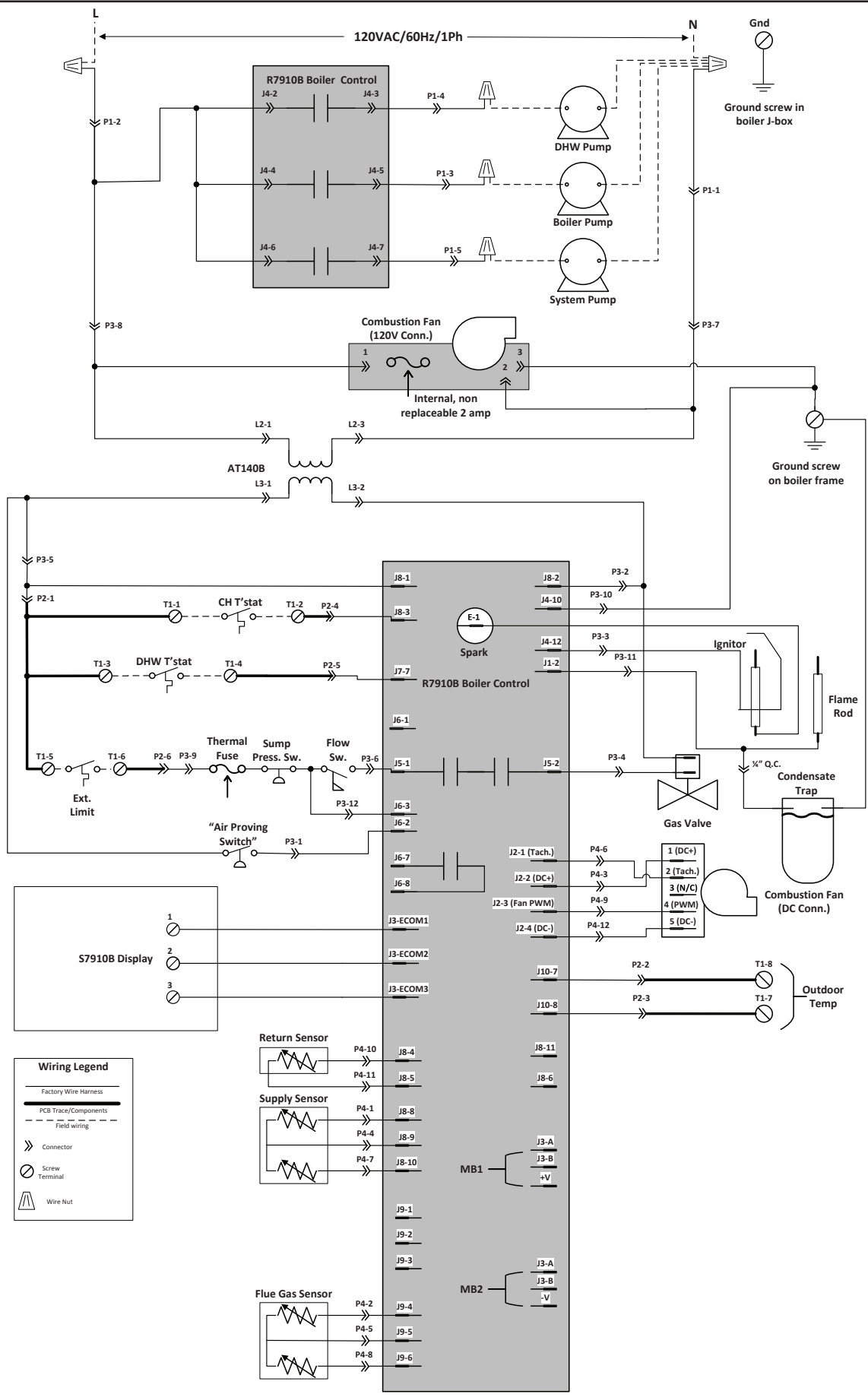

FIGURE 10.5: INTERNAL LADDER DIAGRAM

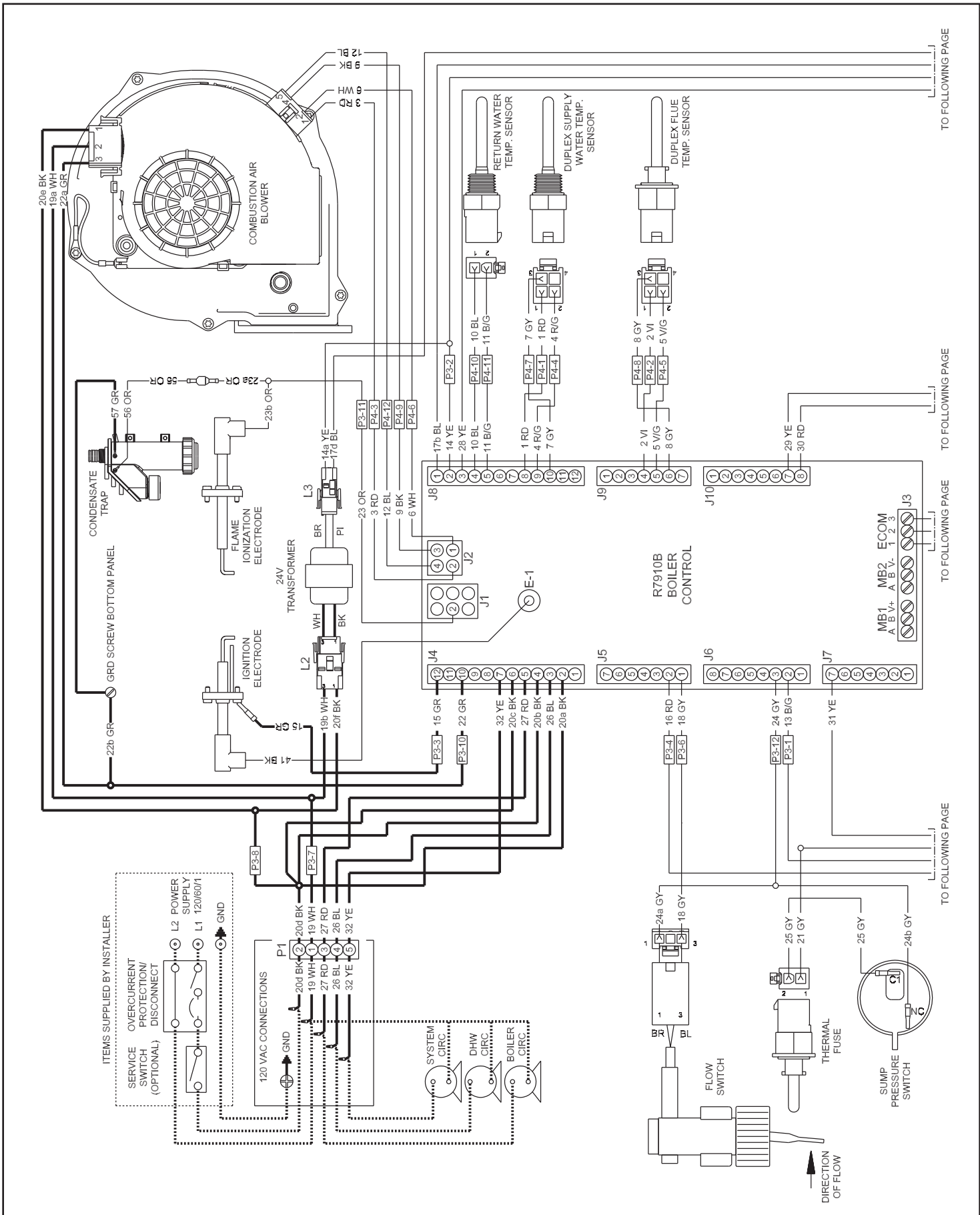

FIGURE 10.6: INTERNAL WIRING CONNECTIONS DIAGRAM

FROM PREVIOUS PAGE

FROM PREVIOUS PAGE

FROM PREVIOUS PAGE

FROM PREVIOUS PAGE

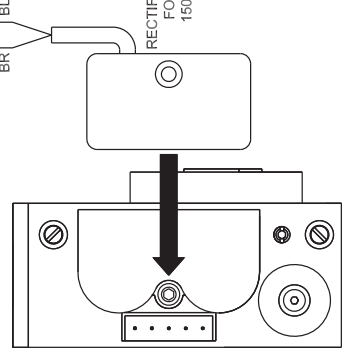
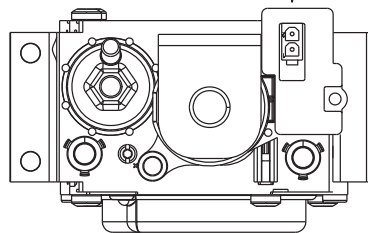
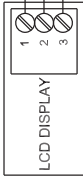
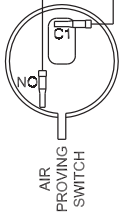

- LOW VOLTAGE FACTORY WIRING SIZE 18 AWG TYPE TEWAWM STRANDED WIRE, 105°C
- LOW VOLTAGE FIELD WIRING
- LINE VOLTAGE FACTORY WIRING SIZE 18 AWG TYPE TEWAWM STRANDED WIRE, 105°C
- LINE VOLTAGE FIELD WIRING
- IGNITOR - 250°C

NOTES:
 1. IF ANY OF THE ORIGINAL WIRE SUPPLIED WITH THE APPLIANCE MUST BE REPLACED, IT MUST BE REPLACED WITH THE SAME TYPE SHOWN OR ITS EQUIVALENT. S'IL FAUT REMPLACER UN FIL QUELCONQUE D'ORIGINE FOURNI AVEC
 2. INSTALL OVER-CURRENT PROTECTION IN ACCORDANCE WITH AUTHORITY HAVING JURISDICTION OR, IN THE ABSENCE OF SUCH REQUIREMENTS, FOLLOW THE NATIONAL ELECTRIC CODE, NFPA 70, AND/OR CSA C22.1 ELECTRICAL CODE. DO NOT PROVIDE OVER-CURRENT PROTECTION GREATER THAN 15 AMPERES.
 3. PLUGS P1 & P2 ARE SHOWN IN LINE IN THE ABOVE DIAGRAM FOR CLARITY. (ALSO SEE BOX AT RIGHT).
 4. PLUGS P3 & P4 ARE LOCATED ON THE TOP OF THE CONTROL BOX. INDIVIDUAL TERMINALS ARE SHOWN IN CALLOUT BOXES IN THE ABOVE DIAGRAM FOR CLARITY (ALSO SEE BOX AT RIGHT).

WIRE COLOR CODE
 BK - BLACK
 BL - BLUE
 BR - BROWN
 GR - GREEN
 GY - GRAY
 OR - ORANGE
 PI - PINK
 RD - RED
 VI - VIOLET
 WH - WHITE
 YE - YELLOW
 R/G - RED W/GRAY TRACER
 B/G - BLUE W/GRAY TRACER
 P/G - PINK W/GRAY TRACER
 V/G - VIOLET W/GRAY TRACER
 Y/G - YELLOW W/GRAY TRACER

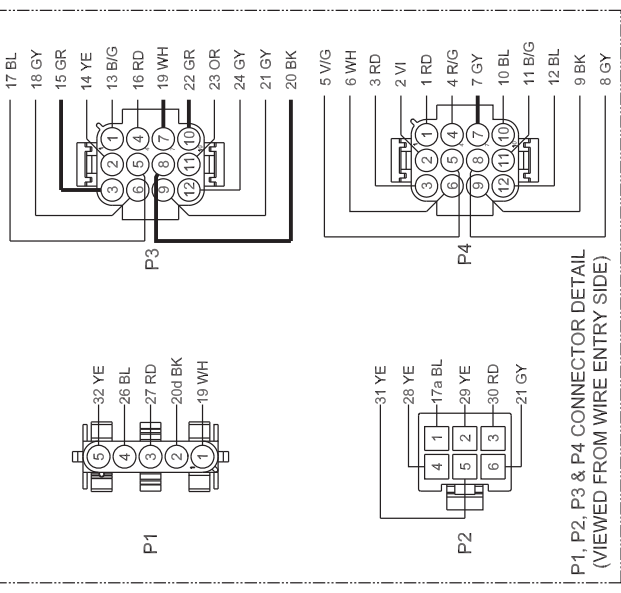

P1, P2, P3 & P4 CONNECTOR DETAIL
 (VIEWED FROM WIRE ENTRY SIDE)

XI Start-up and Checkout

WARNING

Completely read, understand and follow all instructions in this manual before attempting start-up.

NOTICE

Safe lighting and other performance criteria were met with the gas train assembly provided on the boiler when the boiler underwent the test specified in Z21.13.

Use the following procedure for initial start-up of the boiler:

- 1) Verify that the venting, water piping, gas piping and electrical system are installed properly.
- 2) Confirm all electrical, water and gas supplies are turned off at the source and that vent is clear of obstructions.
- 3) Confirm that all manual shut-off gas valves between the boiler and gas source are closed.
- 4) If not already done, flush the system to remove sediment, flux, and traces of boiler additives.
- 5) Fill the boiler and hydronic system with water meeting the following requirements below (also see the note on the next page):
 - pH between 6.5 and 9.5
 - Hardness less than 7 grains/gallon
 - Chlorides less than 200ppm
 - Pressurize the system to at least 12 psi at the boiler

WARNING

Scald Hazard. The maximum operating pressure of this boiler is 30 psig or 50 psig depending on the model and relief valve selected. Never exceed these pressures.

- 6) Bleed air from the heat exchanger using the manual air vent in the top left side of the heat exchanger (Figure 11.1). To do this install a piece of 1/4" ID clear tubing over the hose barb and route the tubing to a location where water will not damage controls or nearby construction. Turn vent counter-clockwise and allow heat exchanger to vent until a steady stream of water is observed. Close vent and remove hose.
- 7) Check all gas piping for leaks and purge piping sections that are filled with air. Refer to the *National Fuel Gas Code* for additional information on testing and purging gas lines.

DANGER

- **Do not use matches, candles, open flames or other ignition source to check for leaks.**
- **Make sure that the area around the boiler is clear and free from combustible materials, gasoline and other flammable vapors and liquids.**

- 8) Confirm vent system is complete and free of obstructions before attempting to fire boiler.
- 9) Inspect all wiring for loose, uninsulated or miswired connections.



DANGER

Asphyxiation Hazard. Failure to properly convert this boiler for use on lp gas can cause unreliable operation at elevated carbon monoxide (CO) levels, resulting in personal injury or death.

NOTICE

To minimize the risk of premature heat exchanger failure, observe the following water chemistry requirements:

- 1) Minimize the introduction of make-up water, dissolved oxygen, and contaminants into the boiler by following the installation guidelines shown in the Water Quality and Boiler Water Additives Note on Page 38.
- 2) Make sure the system is filled with water meeting the following criteria:
 - pH between 6.5 and 9.5 (for systems containing aluminum components, between 6.5 and 8.5)
 - Chloride level less than 200PPM. If fill water is drawn from a system containing a water softener, test a sample of the fill water to confirm that this criteria is met.
 - Hardness less than 7 grains/gallon.
- 3) Avoid the use of petroleum based boiler additives. These can attack seals in both the boiler and system.
- 4) If freeze protection is required, use the following or its equivalent:
 - Fernox Alphi -11 (inhibited Propylene Glycol) available from Alent plc Consumer Products Division, 4100 6th Avenue, Altoona PA. (972) 547 6002 (fernox_usa@alent.com).

Refer to the antifreeze manufacturer's instructions for required dosage. In general these products are a blend of glycol (for freeze protection) and inhibitors (to protect the glycol from attacking metallic system components). Do not add any more antifreeze than is necessary to protect the system from freeze damage. Many of these products require annual testing of the system water to ensure that the inhibitors are still active; consult the manufacturer's instructions for maintenance requirements. Allowance must be made for the additional expansion of the glycol solution.

- 5) For system cleaning, use the following or its equivalent:
 - Fernox Cleaner F3 available from Alent plc Consumer Products Division, 4100 6th Avenue, Altoona PA. (972) 547 6002 (fernox_usa@alent.com).

Refer to the instructions supplied with the cleaner for proper dosage and use.



WARNING

Poison Hazard. Use only inhibited propylene glycol solutions specifically formulated for hydronic systems. Do not use ethylene glycol, which is toxic and can attack gaskets and seals used in hydronic systems. Use of ethylene glycol could result in property damage, personal injury or death.

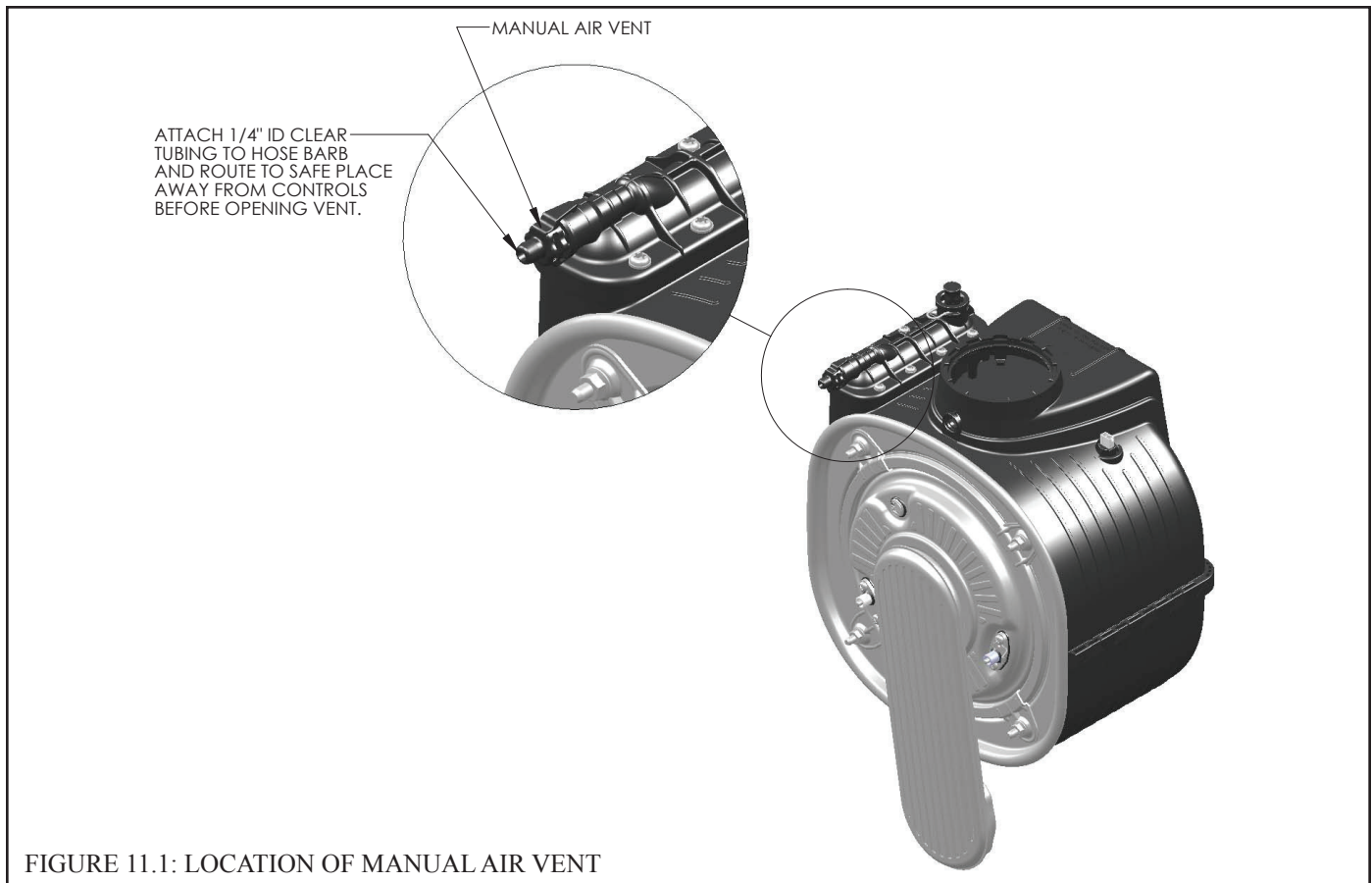

FIGURE 11.1: LOCATION OF MANUAL AIR VENT

- 10) If the boiler is to be converted to propane (LP gas), start-up and adjust throttle as described in Appendix A.
- 11) Start the boiler using the lighting instructions on page 61. With the boiler powered up, and with no call for heat, the display will “boot up” as shown in Figure 11.2a for a period of 1-2 minutes. Once a call for heat is present, the demand code will alternately flash with the outlet temperature. (Figure 11.2b)
- 12) The boiler should attempt to fire approximately 30 seconds after a call for heat appears. With the upper front cover removed from the boiler, this try for ignition will appear as an audible spark (lasting approximately 4 seconds) and an audible click from the gas valve. Upon initial start-up, the gas train will be filled with air. Even if the gas line has been completely purged of air, it may take several tries for ignition before a flame is established. If the boiler does not light after six tries for ignition, it will enter a “Hold” and will wait for one hour before attempting another ignition sequence. This “Hold” can be reset by interrupting power to the boiler for a few seconds. Once a flame has been established for the first time, subsequent calls for burner operation should result in a flame on the first try.
- 13) If there is a problem that appears before the first trial for ignition, or if the boiler fails to light after six tries for ignition, the display will alternately flash the outlet temperature and a “hold code” (Fig. 11.2c). This code is 110 in the case of failure to light after 5 retries for ignition. For more information, and a complete list of Hold codes, see Part XIV of this manual.
- 14) Inspect the flame visible through the window. On high fire the flame should be stable and mostly blue (Fig.11.3). No yellow tipping should be present; however, intermittent flecks of yellow and orange in the flame are normal.
- 15) Check the inlet gas pressure. Verify that the inlet gas pressure is between the upper and lower limits shown on the rating plate with all gas appliances on and off.

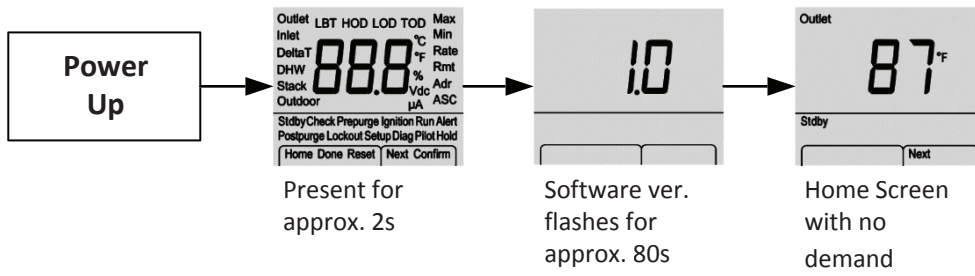

FIGURE 11.2a: HOME SCREEN AT POWER-UP (No Call for Heat)

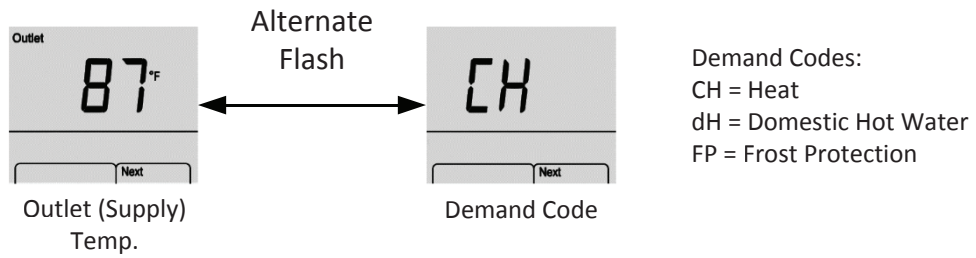

FIGURE 11.2b: HOME SCREEN ON HEAT DEMAND

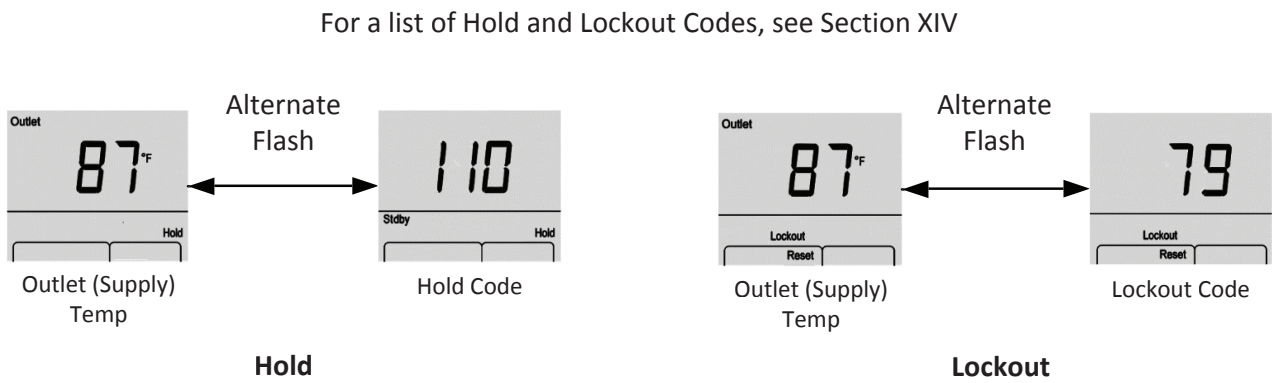

FIGURE 11.2c: HOME SCREEN WITH ACTIVE FAULT

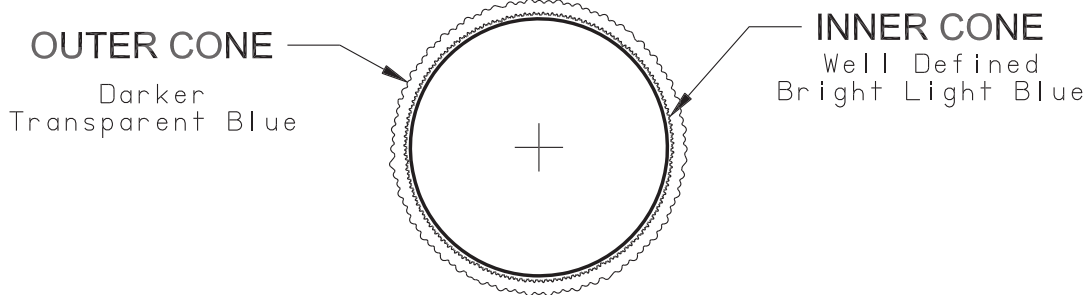

FIGURE 11.3: BURNER FLAME

! WARNING

Asphyxiation Hazard. Each boiler is tested at the factory and adjustments to the air-fuel mixture are normally not necessary when operating on natural gas at sea level. Consult the factory before attempting to make any such adjustments. Improper gas valve or mixture adjustments could result in property damage, personal injury or loss of life due to carbon monoxide (CO) poisoning.

! WARNING

Asphyxiation Hazard. The outlet pressure for the gas valve has been factory set and requires no field adjustment. This setting is satisfactory for both natural gas and propane. Attempting to adjust the outlet pressure may result in damage to the gas valve and cause property damage, personal injury or loss of life due to carbon monoxide (CO) poisoning.

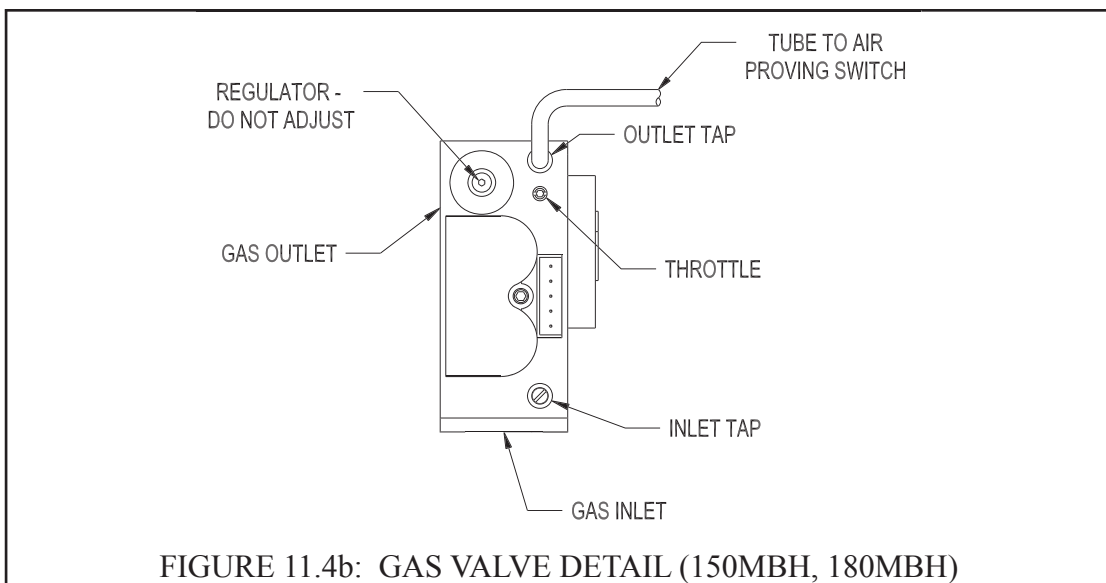
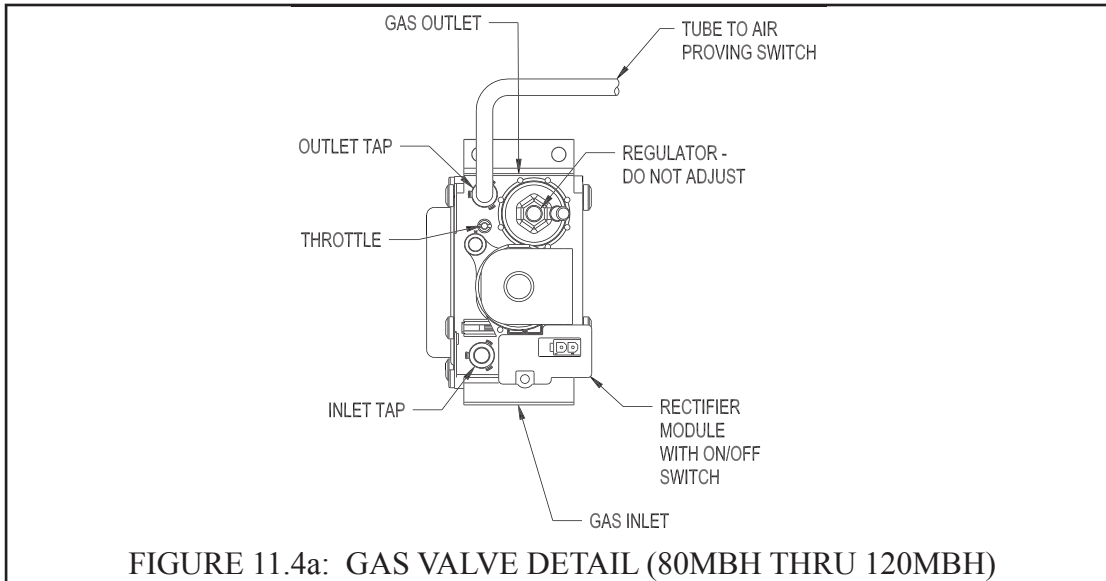

- 16) Perform a combustion test. Boilers are equipped with a screw cap in the vent adapter. Be sure to replace this cap when combustion testing is complete. Check CO₂ (or O₂) and CO at both high and low fire. The boiler may be temporarily locked into high or low fire as follows:
- From the home screen, press and hold both the LH and RH buttons for 3s. The screen will change to into Diagnostic mode and show the flame signal (Figure 12.7).
 - Press the RH (“Next”) button 5 times to advance to the high fire (“HF”) screen.
 - To set the boiler in low fire from the high fire screen, press the LH button 6 more times.
 - To return to automatic firing control from either the HF or LF screens, press the LH (“Done”) button. The boiler will return to automatic modulation from either screen after 15 minutes if no buttons are pressed.
 - At both high and low fire CO readings should be less than 200PPM air-free. Typical CO₂ and O₂ readings are shown in Table 11.5. Final readings should be taken with all doors and covers in place.
- To return to automatic firing control from either the HF or LF screens, press the LH (“Done”) button. The boiler will return to automatic modulation from either screen after 15 minutes if no buttons are pressed.
- 17) Perform a check of the ignition safety shut-off device. With the burner firing, carefully unplug the orange flame rod wire at the flame rod using a pair of insulated pliers (Figure 13.1). The burner should shut off immediately.
- 18) Test any external limits or other controls in accordance with the manufacturer’s instructions.
- 19) Refer to the Operation Section to set-up the control for the system in which the boiler is installed, such as adjusting temperature set points.
- 20) Adjust the heating and indirect water heater thermostats to their final set points.

Model	Fuel	%CO ₂	%O ₂	Max CO Air Free (ppm)
80MBH	Natural Gas	9.0	5.1	200
80MBH	Propane	10.2	5.4	200
100MBH	Natural Gas	9.0	5.1	200
100MBH	Propane	10.2	5.4	200
120MBH	Natural Gas	9.0	5.1	200
120MBH	Propane	10.2	5.4	200
150MBH	Natural Gas	9.0	5.1	200
150MBH	Propane	10.2	5.4	200
180MBH	Natural Gas	9.0	5.1	200
180MBH	Propane	10.2	5.4	200

TABLE 11.5: TYPICAL COMBUSTION READINGS

NOTICE

This boiler has a limited warranty, a copy of which is included with this boiler. It is the responsibility of the installing contractor to see that all controls are correctly installed and are operating properly when the installation is complete.

Lighting and Operating Instructions

FOR YOUR SAFETY READ BEFORE OPERATING/POUR VOTRE SECURITE LISEZ AVANT DE METTRE EN MARCHÉ

WARNING: If you do not follow these instructions exactly, a fire or explosion may result causing property damage, personal injury or loss of life.

AVERTISSEMENT: Quiconque ne respecte pas à la lettre les instructions dans la présente notice risque de déclencher un incendie ou une explosion entraînant des dommages, des blessures ou la mort.

- A. This appliance does not have a pilot. It is equipped with an ignition device which automatically lights the burner. Do not try to light the burner by hand.
- B. BEFORE OPERATING smell all around the appliance area for gas. Be sure to smell next to the floor because some gas is heavier than air and will settle on the floor.

WHAT TO DO IF YOU SMELL GAS:

- Do not try to light any appliance.
 - Do not touch any electric switch; do not use any phone in your building.
 - Immediately call your gas supplier from a neighbor's phone. Follow the gas supplier's instructions.
 - If you cannot reach your gas supplier, call the fire department.
- C. Use only your hand to turn the gas control knob. Never use tools. If the knob will not turn by hand, don't try to repair it, call a qualified service technician. Force or attempted repair may result in a fire or explosion.
- D. Do not use this appliance if any part has been under water. Immediately call a qualified service technician to inspect the appliance and to replace any part of the control system and any gas control which has been under water.

- A. Cet appareil ne comporte pas de veilleuse. Il est muni d'un dispositif d'allumage qui allume automatiquement le brûleur. Ne tentez pas d'allumer le brûleur manuellement.
- B. AVANT DE FAIRE FONCTIONNER, reniflez tout autour de l'appareil pour déceler une odeur de gaz. Reniflez près du plancher, car certains gaz sont plus lourds que l'air et peuvent s'accumuler au niveau du sol.

QUE FAIRE SI VOUS SENTEZ UNE ODEUR DE GAZ:

- Ne pas tenter d'allumer d'appareil.
 - Ne touchez à aucun interrupteur ; ne pas vous servir des téléphones se trouvant dans le bâtiment.
 - Appelez immédiatement votre fournisseur de gaz depuis un voisin. Suivez les instructions du fournisseur.
 - Si vous ne pouvez rejoindre le fournisseur, appelez le service des incendies.
- C. Ne poussez ou tournez la manette d'admission du gaz qu'à la main ; ne jamais utiliser d'outil. Si la manette reste coincée, ne pas tenter de la réparer ; appelez un technicien qualifié. Le fait de forcer la manette ou de la réparer peut déclencher une explosion ou un incendie.
- D. N'utilisez pas cet appareil s'il a été plongé dans l'eau, même partiellement. Faites inspecter l'appareil par un technicien qualifié et remplacez toute partie du système de contrôle et toute commande qui ont été plongés dans l'eau.

OPERATING INSTRUCTIONS/ INSTRUCTIONS DE FONCTIONNEMENT

1. STOP! Read safety information above on this label.
2. Set the thermostat to lowest setting.
3. Turn off all electric power to the appliance.
4. This appliance is equipped with an ignition device which automatically lights the burner. Do not try to light the burner by hand.
5. Turn the external boiler manual gas valve handle clockwise ↻ to close the gas supply.
6. Wait five (5) minutes to clear out any gas. Then smell for gas, including near the floor. If you smell gas, STOP! Follow "B" in the safety information above on this label. If you don't smell gas, go to the next step.
7. Turn the external boiler manual gas valve handle counterclockwise ↺ to open the gas supply.
8. Turn on all electric power to the appliance.
9. Set the thermostat to the desired setting.
10. If the appliance will not operate, follow the instructions "To Turn Off Gas To Appliance" and call your service technician or gas supplier.

OPEN/OUVERT

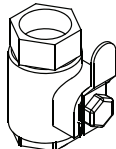

CLOSED/FERMÉ

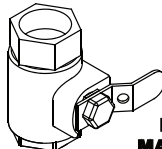

EXTERNAL BOILER
MANUAL GAS VALVE
LA CHAUDIÈRE EXTERNE
MANUELLE DE CLAPET À GAZ

1. ARRÊTEZ ! Lisez les instructions de sécurité sur la portion supérieure cette étiquette.
2. Réglez le thermostat à la température la plus basse.
3. Coupez l'alimentation électrique de l'appareil.
4. Cet appareil est équipé de l' dispositif d'allumage qui automobile allume maticallyle brûleur. Ne tentez pas d'allumer le brûleur manuellement.
5. Tourner la chaudière externe manuelle poignée ↻ en clapet à gaz dans le sens des aiguilles d'une montre pour fermer l'offre de gaz.
6. Attendre cinq (5) minutes pour laisser échapper tout le gaz. Reniflez tout autour de l'appareil, y compris près du plancher, pour déceler une odeur de gaz. Si vous seutez une odeur de gaz, ARRÊTEZ ! Passez à l'étape B des instructions de sécurité sur la portion supérieure de cette étiquette. S'il n'y a pas d'odeur de gaz, passez à l'étape suivante.
7. Tourner la chaudière externe manuelle compteur de poignée ↻ en clapet à gaz ouvrir dans le sens des aiguilles d'une montre le gaz approvisionnement.
8. Mettez l'appareil sous tension.
9. Réglez le thermostat à la température désirée.
10. Si l'appareil ne se met pas en marche, suivez les instructions intitulées « Comment couper l'admission de gaz de l'appareil » et appelez un technicien qualifié ou le fournisseur de gaz.

TO TURN OFF GAS TO APPLIANCE/ COMMENT COUPER L'ADMISSION DE GAZ DE L'APPAREIL

1. Set the thermostat to lowest setting.
2. Turn off all electric power to the appliance if service is to be performed.
3. Turn the external boiler manual gas valve handle clockwise ↻ to close gas supply.

1. Réglez le thermostat à la température la plus basse.
2. Coupez l'alimentation électrique de l'appareil s'il faut procéder à l'entretien.
3. Tourner la chaudière externe manuelle poignée ↻ en clapet à gaz dans le sens des aiguilles d'une montre pour fermer l'offre de gaz.

XII Operation

A. General Information

This boiler uses the microprocessor based Honeywell R7910B (“boiler control”) to manage all boiler functions including flame supervision and modulation. Two set point or “target” boiler supply temperatures are stored in the control’s memory; one for space heating (CH) and one for domestic hot water (DHW) production. If an outdoor temperature sensor is connected to the boiler, and enabled, the space heating supply set point will automatically shift downward as the outdoor temperature increases. For more information on this feature see the discussion on boiler water reset below. The control modulates the boiler input by varying the fan speed. As the fan speed increases, so does the amount of gas drawn into the blower. As a result, a fairly constant air-fuel ratio is maintained across all inputs. The control determines the input needed by looking at both current and recent differences between the supply temperature and the set point temperature. As the supply temperature approaches the set point temperature, the fan will slow down and the input will drop. The minimum input is approximately 1/5 of maximum input. This boiler control also monitors boiler return and flue temperatures. In addition, all other safety controls are connected into the R7910B. The R7910B uses inputs from all of these controls to either shut down the boiler when an unsafe condition exists or, in some cases, to correct the problem. Finally, the R7910B manages up to three pumps:

- Boiler pump
- DHW pump
- System pump

Refer to the Piping Section for the location of these pumps.

The boiler’s status, as well as all settings, are viewed and adjusted using the control panel (“display”) on the front of the boiler (Figure 12.0). This display has three basic modes of operation:

- 1) User Mode - This is the default mode of operation for the control. By default, the display shows the home screen shown in Figure 12.0. By pressing the LH or RH buttons at the bottom of the screen, it is possible to navigate to other User Mode screens. See Figure 12.1 for a description of all User Mode screens.
- 2) Set-up Mode – This mode is used to adjust settings, such as target water temperature. To reach Set-up Mode, hold both the Up and DWN keys for at least 3 seconds. All Set-up Mode screens are shown in Figure 12.2 and all settings are described in more detail in Part B of this section.
- 3) Diagnostic Mode – Diagnostic Mode is used to obtain information about recent faults, as well as to temporarily lock the input at high or low fire for the purpose of running combustion tests. To reach Diagnostic Mode, hold both the LH and RH keys for at least 3 seconds. All Diagnostic Mode screens are shown in Figure 12.7 and the use of these screens is described both in this section and in Section XIV.



This control panel is provided to enable a professional HVAC technician to set-up, check, and troubleshoot this boiler. Attempts by others to make adjustments using this control panel could result in death, personal injury, property damage, or unreliable operation.

B. Setting Up the Control

Enter Set-up Mode by pressing and holding both the UP and DWN buttons for at least 3s. The RH (Next) button advances through the screens on this menu, saving any changes on the way. The LH (Done) button saves changes and returns to User Mode. All Set-up Mode screens are shown in Figure 12.2. A description of each is as follows:

Temperature Units (S0) – Used to select temperature units shown on the display.

CH Set point (S1) - Target water temperature when the boiler is responding to a call for space heat. If outdoor reset is enabled, this is the maximum target water temperature, regardless of outdoor temperature. See the Odr section below, as well as Figure 12.3, for more information on outdoor reset.

Odr (S2) – Outdoor reset function status. This screen indicates whether the Odr function is on or off by alternately flashing “Odr” and either “On” or “OFF”.

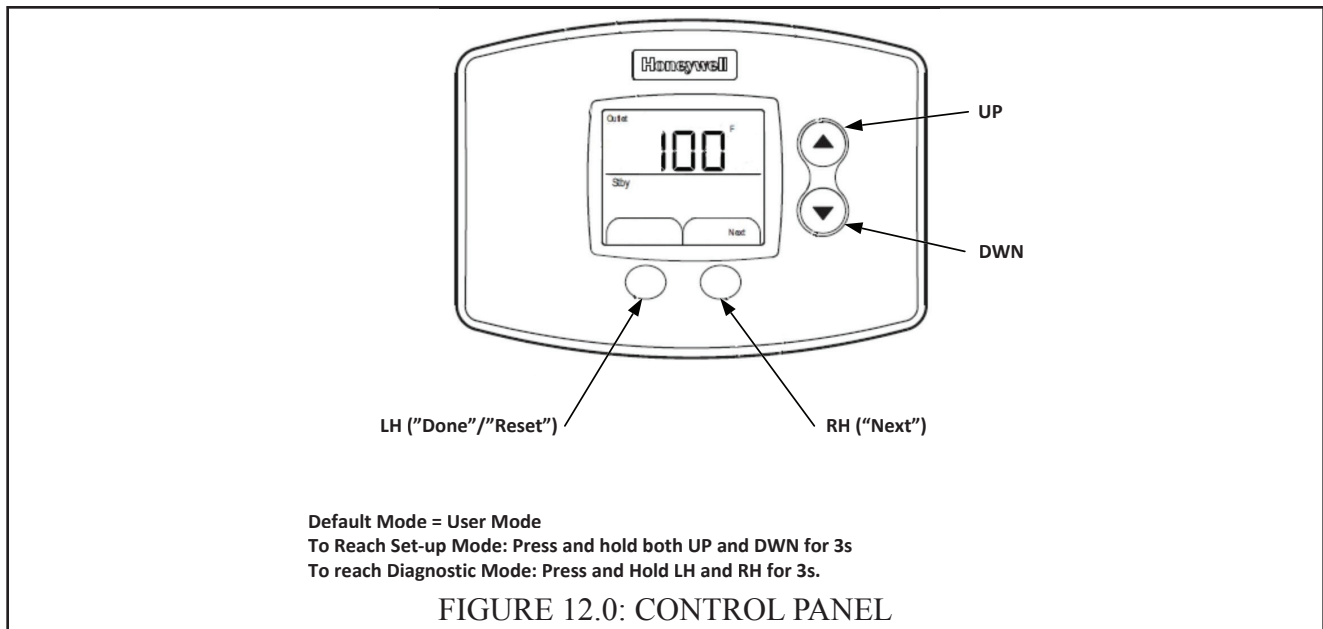

When Odr is on, and when the boiler is responding to a call for space heat, the target water temperature will adjust downward (within certain limits) as the outdoor temperature increases. The graph in Figure 12.3 shows how the target water temperature changes with outdoor temperature. This control strategy increases system efficiency by keeping the water temperature closer to the minimum value needed to heat the building based on the current outdoor air temperature.

Figure 12.3 shows the default reset curve; the ends of this curve can be changed by adjusting the CH Set point, LBT (“Low Boiler Temp”), HOD (“High Outdoor Temp”), and LOD (“Low Outdoor Temp”). The ideal values for these four settings depend upon the type of radiation in the building. The default values will generally provide adequate comfort regardless of the type of radiation used.

The default ODR setting is “On”, but it can be turned off by pressing either the UP or DWN keys. The outdoor reset function should not be turned off unless at least one of the conditions listed in the “IMPORTANT” box below is met. If ODR is turned off, the screens for adjusting LBT, HOD, and LOT are not visible.

LBT (S3) – Low Boiler Temperature. See Figure 12.3 and the Odr discussion above.

HOD (S4) – High outdoor temperature. See Figure 12.3 and the Odr discussion above.

LOD (S5) – Low outdoor temperature. See Figure 12.3 and the Odr discussion above.

dH (S6) – Domestic hot water (DHW) set point. This is the set point of the boiler supply temperature during a call for DHW. Control of the potable water temperature itself is accomplished using the thermostat on the storage type indirect water heater.

ASC (S7) – Anti short cycle time. This setting can be used to enforce a minimum period of time between calls for CH. Default is zero.

IMPORTANT

This boiler is equipped with a feature that saves energy by reducing the boiler water temperature as the heating load decreases. This feature is equipped with an override which is provided primarily to permit the use of an external energy management system that serves the same function. **THIS OVERRIDE MUST NOT BE USED UNLESS AT LEAST ONE OF THE FOLLOWING CONDITIONS IS TRUE:**

- An external energy management system is installed that reduces the boiler water temperature as the heating load decreases.
- This boiler is not used for any space heating.
- This boiler is part of a modular or multiple boiler system having a total input of 300,000 BTU/hr or greater.

! WARNING

Burn Hazard. Water temperatures over 125°F can cause personal injury or death due to scalding. Children, Disabled, and Elderly are at most risk of being scalded. This boiler is not designed to directly control domestic water temperature.

- Use only the thermostat recommended by the indirect water heater manufacture to control the DHW temperature.
- Adjust the thermostat set point in accordance with the indirect water heater manufacturer’s instructions.
- Install scald protection devices as required by the indirect water heater manufacturer or local codes.
- Do not attempt to wire a DHW sensor into the boiler control.

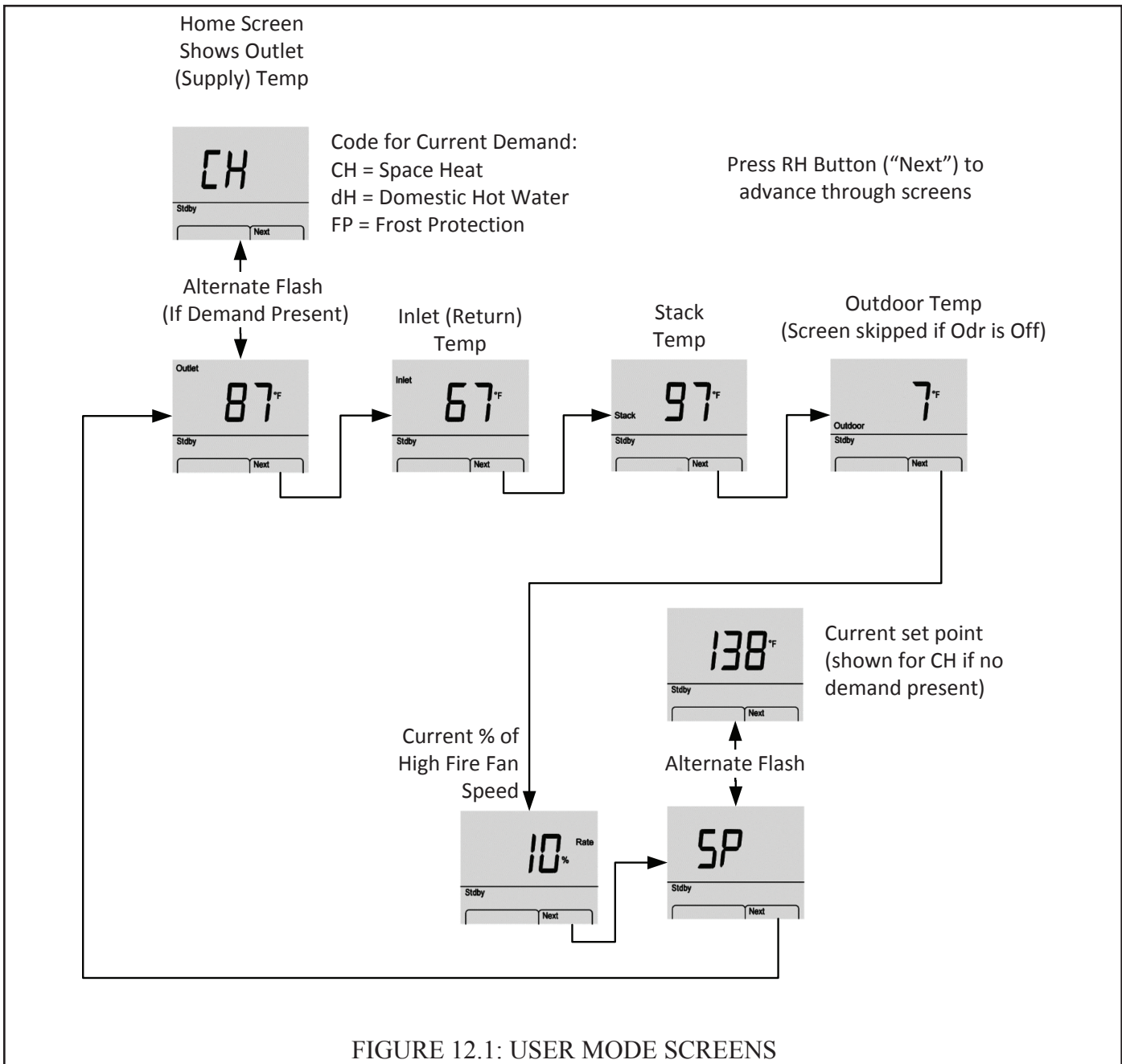
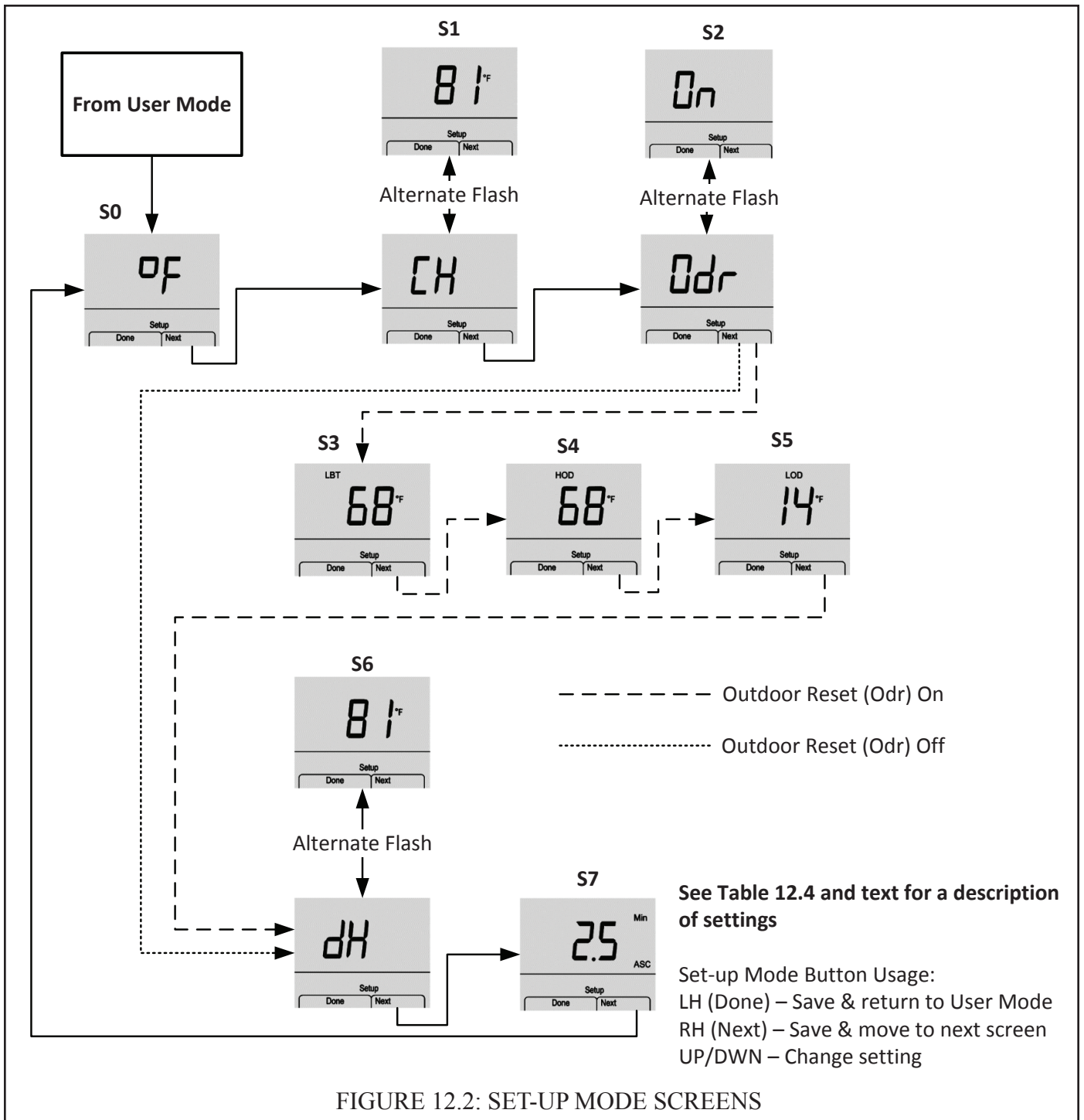

FIGURE 12.1: USER MODE SCREENS



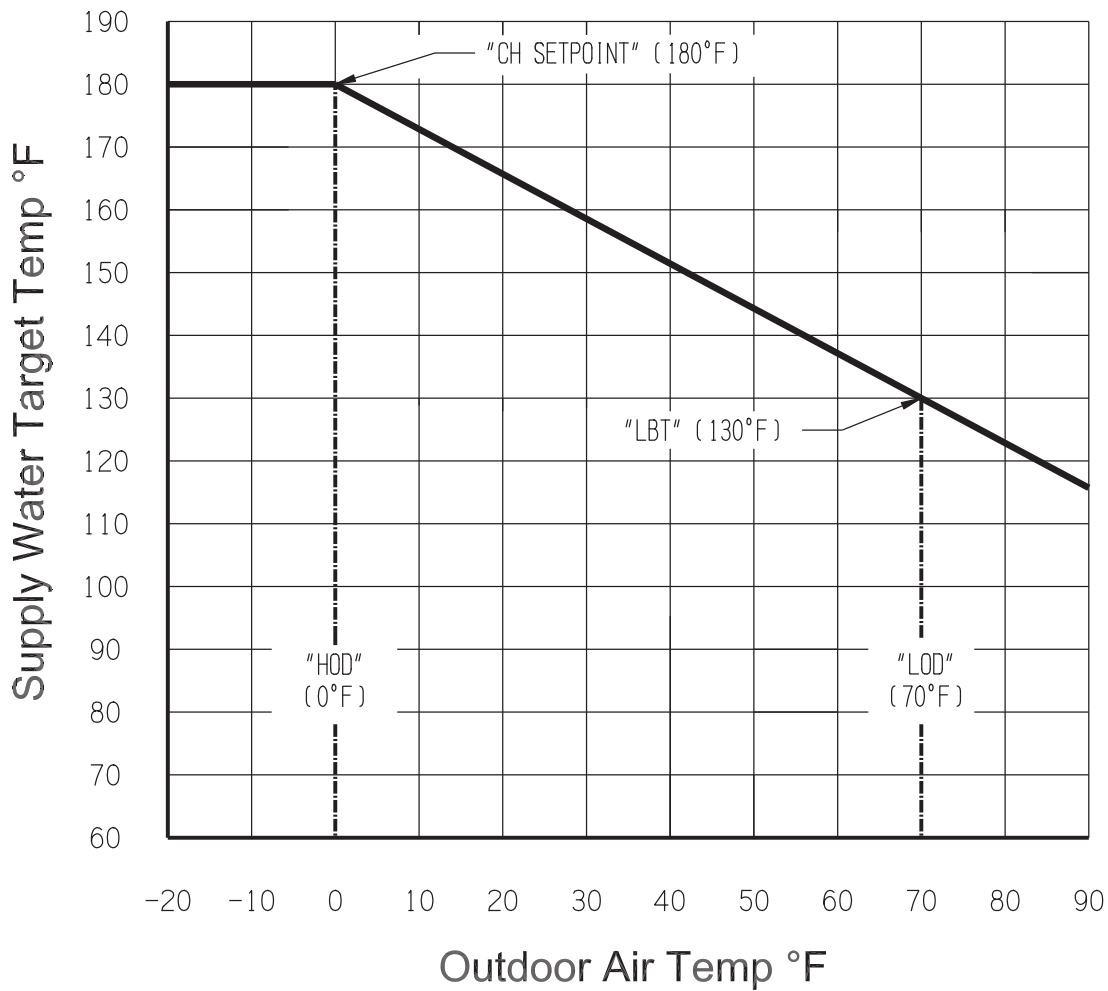

FIGURE 12.3: OUTDOOR RESET CURVE (DEFAULT SETTINGS SHOWN)

TABLE 12.4: Default Settings and Ranges

Scr. #	Description on Screen	Description	Default Value	Allowable Range
S0	“F” or “C”	Temperature Units	F	F or C
S1	“CH”	Heating set point (max temperature set-point upon a call for space heat)	180F	32 - 191F
S2	“Odr”	Outdoor Reset Enable	On	On or Off
S3	“LBT”	Low boiler temp (Fig 12.3)	130F	69 - 191F
S4	“HOD”	High outdoor temp (Fig 12.3)	70F	31 - 101F
S5	“LOD”	Low outdoor temp (Fig 12.3)	0F	-40 - 100F
S6	“dH”	Boiler water set point on call for domestic hot water	170F	32 - 191F
S7	ASC	Anti short cycle time	0	0 - 15m

C. Pump Control and DHW Priority

Pump operation in response to different demands is shown in Table 12.5. This behavior cannot be changed.

Like all boilers, this one is capable of regulating only one target boiler water temperature at any given time. This means that priority must be given to either the CH or DHW target temperature. For this reason, the boiler gives priority to the DHW demand for the first 60 minutes during which both calls for CH and DHW continuously exist. If there are still simultaneous calls for DHW and CH at the end of this time, the boiler will continue to use the DHW target temperature, but will also operate the system pump in an attempt to satisfy the call for heat. The boiler will once again use the CH target temperature when the call for DHW ends.



CAUTION

Radiant heating systems generally require much lower boiler supply temperatures than those required for a DHW demand. Such systems can be damaged by excessive water temperatures. When such damage is possible, use an external control, such as a thermostatic mixing valve to limit the temperature of the water entering the heating system.

TABLE 12.5: Summary of Target Temp and Pump Behavior

Status of:	Demands				
	None	CH Only	DHW Only	CH + DHW (<60min)	CH + DHW (>60min)
Boiler Pump	OFF	ON	ON	ON	ON
DHW Pump	OFF	OFF	ON	ON	ON
System Pump	OFF	ON	OFF	OFF	ON
Target Temp	NONE	CH	DHW	DHW	DHW

D. Frost Protection

Frost Protection starts the boiler and system pump, and fires the boiler, when low supply water temperatures and/or extremely low outside air temperatures are sensed. The control does this as shown in Table 12.6.

TABLE 12.6: Frost Protection Behavior

Device	Started When	Stopped When
Boiler & System Pump	Outdoor Sensor less than 0F OR Boiler Supply Sensor less than 45F	Outdoor Sensor greater than 2F OR Boiler Supply Sensor greater than 45F
Burner	Boiler Supply Sensor less than 38F	Boiler Supply Sensor greater than 50F



CAUTION

The boiler control helps provide freeze protection for the boiler water. Boiler flue gas condensate drain is not protected from freezing. Since the Control only controls the system and boiler circulators individual zones are not necessarily protected. It is recommended that the boiler be installed in a location that is not exposed to freezing temperatures.

E. Diagnostic Mode

Enter Diagnostic Mode by pressing and holding both the LH and RH buttons for at least 3s. The RH (“Next”) button navigates between screens. The LH (“Done”) button returns to User Mode. All Diagnostic Mode screens are shown in Figure 12.7. A description of each is below. For more information on troubleshooting, see Section XIV.

uA – Flame signal in micro-Amps. This is shown as “---“ when the burner is off.

Alert – Not used (screen will always read zero).

Lockout – Shows the code for the most recent lockout that occurred. If none have occurred since this control was powered up, this screen will read zero. A list of lockout codes is shown in Section XIV.

ΔT – Shows the current difference between the supply and return temperatures.

LF – Forces the burner to run at low fire if it is on (used for combustion testing). Pressing the LH (“Done”) button returns the user to User mode and also returns the burner to automatic modulation. If no button on pressed while on this screen for 15 minutes, control panel will automatically return to User Mode and burner will return to automatic operation.

HF – Forces the burner to run at high fire if it is on (used for combustion testing). As with the LF screen, pressing the LH (“Done”) button or staying on this screen for 15 minutes without touching a button returns the user to User Mode and also restores automatic modulation.

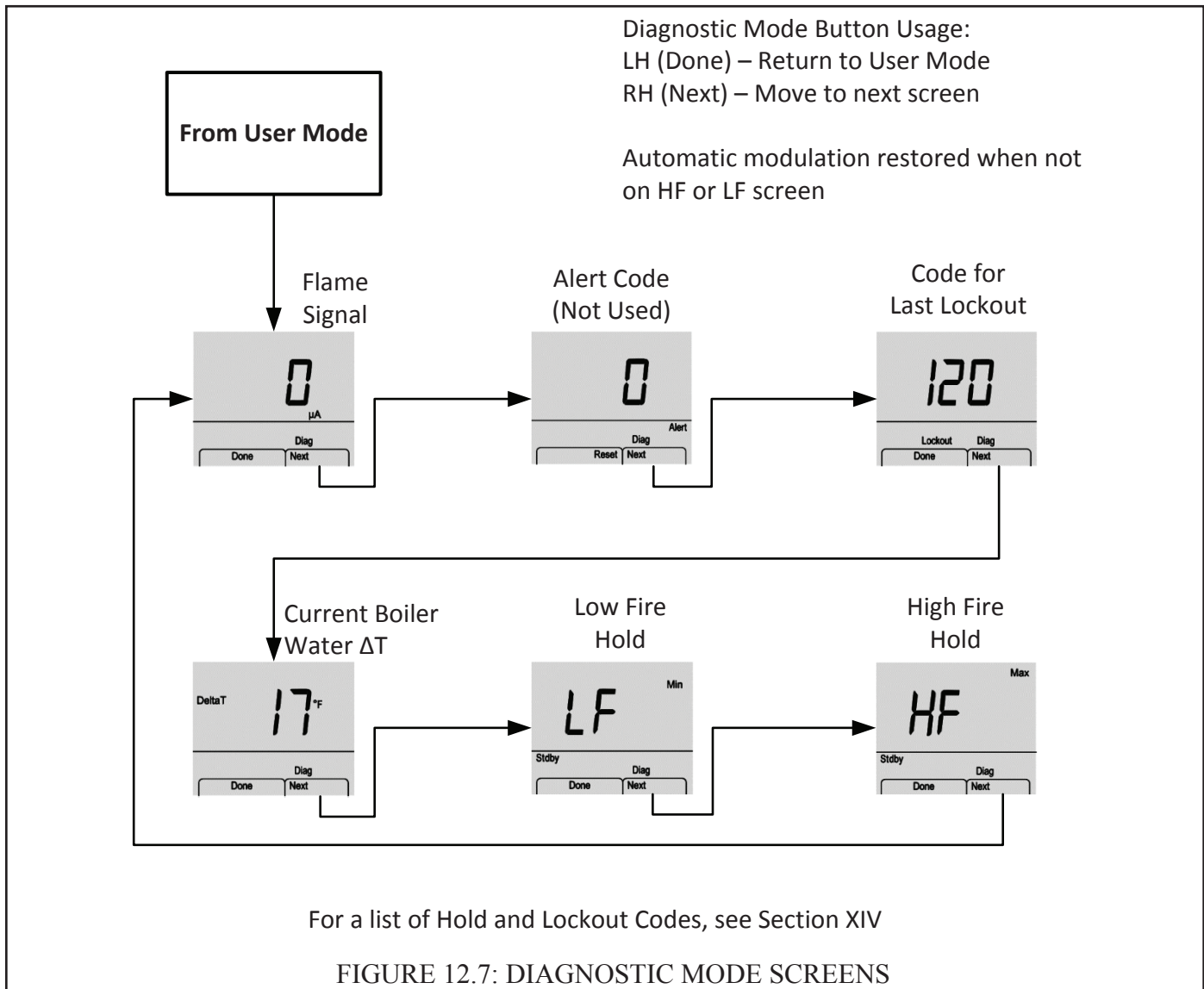

XIII. Service and Maintenance



WARNING

- **Asphyxiation Hazard. Fire Hazard. Explosion Hazard.** This boiler requires regular maintenance and service to operate safely. Follow the instructions contained in this manual.
- **Improper installation, adjustment, alteration, service or maintenance can cause property damage, personal injury or loss of life.** Read and understand the entire manual before attempting installation, start-up operation, or service. Installation and service must be performed only by an experienced, skilled, and knowledgeable installer or service agency.



DANGER

- **Explosion Hazard. Electrical Shock Hazard. Burn Hazard.** This boiler uses flammable gas, high voltage electricity, moving parts, and very hot water under high pressure. Assure that all gas and electric power supplies are off and that the water temperature is cool before attempting any disassembly or service.
- **Do not attempt any service work if gas is present in the air in the vicinity of the boiler.** Never modify, remove or tamper with any control device.



WARNING

- This boiler must only be serviced and repaired by skilled and experienced service technicians.
- If any controls are replaced, they must be replaced with identical models.
- Read, understand and follow all the instructions and warnings contained in all the sections of this manual.
- If any electrical wires are disconnected during service, clearly label the wires and assure that the wires are reconnected properly.
- Never jump out or bypass any safety or operating control or component of this boiler.
- Assure that all safety and operating controls and components are operating properly before placing the boiler back in service.
- Annually inspect all vent gaskets and replace any exhibiting damage or deterioration.
- **Burn Hazard.** This boiler contains very hot water under pressure. Do not unscrew any pipe fittings nor attempt to disconnect any components of this boiler without positively assuring the water is cool and has no pressure. Always wear protective clothing and equipment when installing, starting up or servicing this boiler to prevent scald injuries. Do not rely on the pressure and temperature gauges to determine the temperature and pressure of the boiler. This boiler contains components which become very hot when the boiler is operating. Do not touch any components unless they are cool.
- **Respiratory Hazard.** Boiler materials of construction, products of combustion and the fuel contain alumina, silica, heavy metals, carbon monoxide, nitrogen oxides, aldehydes and/or other toxic or harmful substances which can cause death or serious injury and which are known to the state of California to cause cancer, birth defects and other reproductive harm. Always use proper safety clothing, respirators and equipment when servicing or working nearby the appliance.
- Failure to follow all instructions in the proper order can cause personal injury or death. Read all instructions, including all those contained in component manufacturers manuals which are provided with the boiler before installing, starting up, operating, maintaining or servicing.
- All cover plates, enclosures and guards must be in place at all times.

NOTICE

Warranty does not cover boiler damage or malfunction if the following steps are not performed at the intervals specified.

1) Continuously:

- a. **Keep the area around the boiler** free from combustible materials, gasoline and other flammable vapors and liquids.
- b. **Keep the area around the combustion air inlet terminal** free from contaminants.
- c. **Keep the boiler room ventilation openings** open and unobstructed.

2) Monthly Inspections:

- a. **Inspect the vent piping and outside air intake piping** to verify they are open, unobstructed and free from leakage or deterioration. Call the service technician to make repairs if needed.
- b. **Inspect the condensate drain system** to verify it is leak tight, open and unobstructed. Call the service technician if the condensate drain system requires maintenance.
- c. **Inspect the water and gas lines** to verify they are free from leaks. Call the service technician to make repairs if required.

NOTICE

Water leaks can cause severe corrosion damage to the boiler or other system components. Immediately repair any leaks found.

4) Annual Inspections and Service: In addition to the inspections listed above, the following should be performed by a service technician once every year.

- a. **Follow the procedure** for turning the boiler off found in the Lighting and Operating Instructions, on page 59.
- b. **Turn off all power** to the boiler.
- c. **Inspect the wiring** to verify the conductors are in good condition and attached securely.



CAUTION / ATTENTION

Electrical Shock Hazard. Label all wires prior to disconnection when servicing controls. Wiring errors can cause improper and dangerous operation. Verify proper operation after servicing.

Au moment de l'entretien des commandes, étiquetez tous les fils avant de les débrancher. Les erreurs de câblage peuvent nuire au bon fonctionnement et être dangereuses. S'assurer que l'appareil fonctionne adéquatement une fois l'entretien terminé.

- d. **Verify that the gas shutoff** shown in Figure 8.1 is closed
- e. **Disconnect the union** under the boiler (Figure 8.1).
- f. **Remove the 8-32 nuts** securing the gas escutcheon plate to the bottom cabinet panel.



WARNING

Fire Hazard. Explosion Hazard. Always use a back-up wrench on the gas union when making or breaking this connection. Failure to do so can cause adjacent threaded connections to loosen or damage to the gas valve. Check all internal gas piping for leaks any time it is disconnected or disturbed during servicing.

- g. **Unplug the electrical connection** to the gas valve.
- h. **Disconnect the air proving switch tube** from the gas valve outlet tap.
- i. **Unplug the power and speed control cables** from the blower.

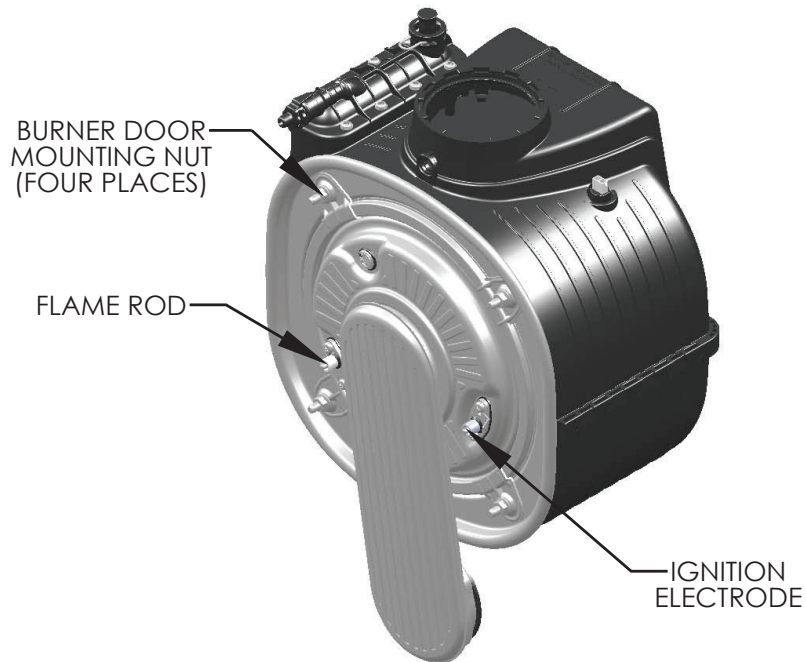

FIGURE 13.1: FLAME IONIZATION ELECTRODE AND IGNITION ELECTRODE LOCATION

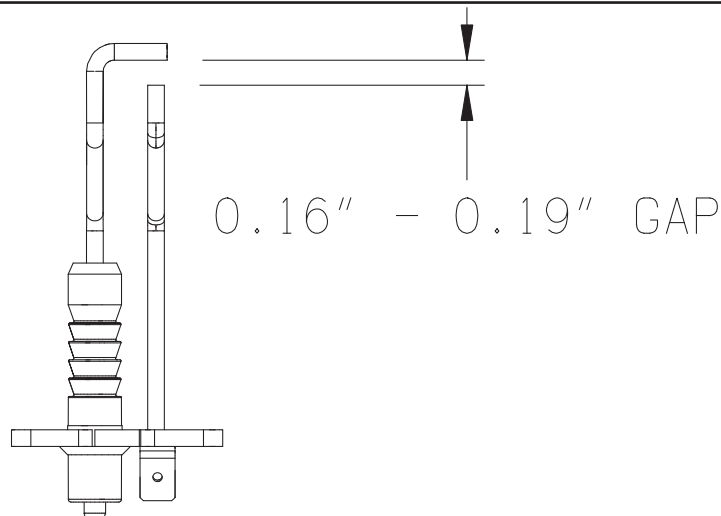

FIGURE 13.2: IGNITION ELECTRODE GAP

- j. **Unplug the ignition, ground, and flame rod wires** from the ignition electrode and the flame rod (Figure 13.1).
- k. **Use a 10mm wrench to remove the four nuts** securing the fire door to the heat exchanger (Figure 13.1). Carefully remove the door/blower/gas valve assembly from the heat exchanger, being careful not to damage the refractory insulation on the inside of the door (see Refractory Warning on next page) or the electrodes.
- l. **Inspect the heat exchanger combustion chamber and vacuum** any debris found on the coil surfaces. If necessary, the coils may be brushed with a nonabrasive, nonmetallic brush. Do not use cleaning agents, solvents, acid or alkali products of any type to clean the heat exchanger .
- m. **Inspect the target wall and fire door insulation.** If either shows signs of damage, it must be replaced.
- n. **Inspect the burner for heat damage** or other deterioration. Use a non-metallic brush or source of compressed air to clean off dust or debris from ports.

- o. **Inspect the ignition electrode and flame rod** for deposits. Clean any found with steel wool. Do not use sand paper or Emory cloth for this cleaning. Inspect the ceramic portion of both of these parts for cracks and replace if any are found. Verify that the ignition electrode gap is within the range shown in Figure 13.2
- p. **Inspect the blower gas valve assembly**, looking for dust, lint, or other debris that may have been drawn into this assembly. Excessive deposits may be vacuumed out.

The blower/gas valve assembly used on the 150MBH and 180MBH may be disassembled to expose the “swirl plate” (Figure 13.4). If it is necessary to clean the swirl plate, carefully note the orientation of all parts during disassembly and use care not to damage the swirl plate vanes. The venturi assembly used on the 80, 100, and 120 cannot be removed from the blower.

Inspect all rubber and plastic components on the blower/gas valve assembly, looking for deterioration. Replace blower and/or gas valve if deterioration is found.

- q. **Inspect and clean the condensate trap.** Place a bucket under the condensate cleanout cap on the bottom of the boiler (Figure 2.1) to catch water in the trap as well as the ball and ball support. Unscrew the cap, being careful not to lose the ball or ball support. Flush any debris found in the trap with water – do not use other cleaning agents. Reassemble the trap as shown in Figure 13.3.



WARNING

Asphyxiation Hazard. Do not operate the boiler without the ball and ball support in place. Doing so could result in flue gas leakage into the indoors resulting in personal injury or death from Carbon Monoxide (CO) poisoning.

NOTICE

Attempting to clean the heat exchanger or trap with anything other than water could result in condensate backup, causing the boiler to shut-down.

- r. **Reinstall the fire door/blower/gas valve assembly**, following the above steps in reverse order.



CAUTION

Do not over tighten fire door mounting nuts. Doing so could break the fire door mounting studs. If any of these studs are damaged, the heat exchanger must be replaced. Use of a short 10mm box wrench will reduce the risk of damaging these studs.

- s. **Inspect the vent system to verify that:**
- All gaskets and joints between the boiler heat exchanger and terminal are leak tight.
 - All supports are intact and vent system is properly pitched
 - All pipe is in good condition. Look for damage such as cracks, heat distortion, discoloration, and embrittlement. If any such damage is found, the pipe must be replaced and the cause of the damage identified.
 - Vent/Intake terminals are in good condition, free from blockages, and still correctly located relative to doors, windows, decks, etc.
 - There is no gasoline, flammable liquids/vapors, or halogen based products stored in the vicinity of the vent or inlet terminals. Also verify that there are no chemical products containing chlorine, chloride based salts, chlorofluorocarbons, paint removers, cleaning solvents, or detergents stored near the air intake terminal.

Refer to Part VII (Venting) to re-assemble any vent system components that are disassembled during this inspection. Also refer to Part VII for details on supporting, pitching, and terminating the vent system.

Important Product Safety Information **Refractory Ceramic Fiber Product**

Warning:

The Repair Parts list designates parts that contain refractory ceramic fibers (RCF). RCF has been classified as a possible human carcinogen. When exposed to temperatures above 1805°F, such as during direct flame contact, RCF changes into crystalline silica, a known carcinogen. When disturbed as a result of servicing or repair, these substances become airborne and, if inhaled, may be hazardous to your health.

AVOID Breathing Fiber Particulates and Dust

Precautionary Measures:

Do not remove or replace RCF parts or attempt any service or repair work involving RCF without wearing the following protective gear:

1. A National Institute for Occupational Safety and Health (NIOSH) approved respirator
 2. Long sleeved, loose fitting clothing
 3. Gloves
 4. Eye Protection
- Take steps to assure adequate ventilation.
 - Wash all exposed body areas gently with soap and water after contact.
 - Wash work clothes separately from other laundry and rinse washing machine after use to avoid contaminating other clothes.
 - Discard used RCF components by sealing in an airtight plastic bag. RCF and crystalline silica are not classified as hazardous wastes in the United States and Canada.

First Aid Procedures:

- If contact with eyes: Flush with water for at least 15 minutes. Seek immediate medical attention if irritation persists.
- If contact with skin: Wash affected area gently with soap and water. Seek immediate medical attention if irritation persists.
- If breathing difficulty develops: Leave the area and move to a location with clean fresh air. Seek immediate medical attention if breathing difficulties persist.
- Ingestion: Do not induce vomiting. Drink plenty of water. Seek immediate medical attention.

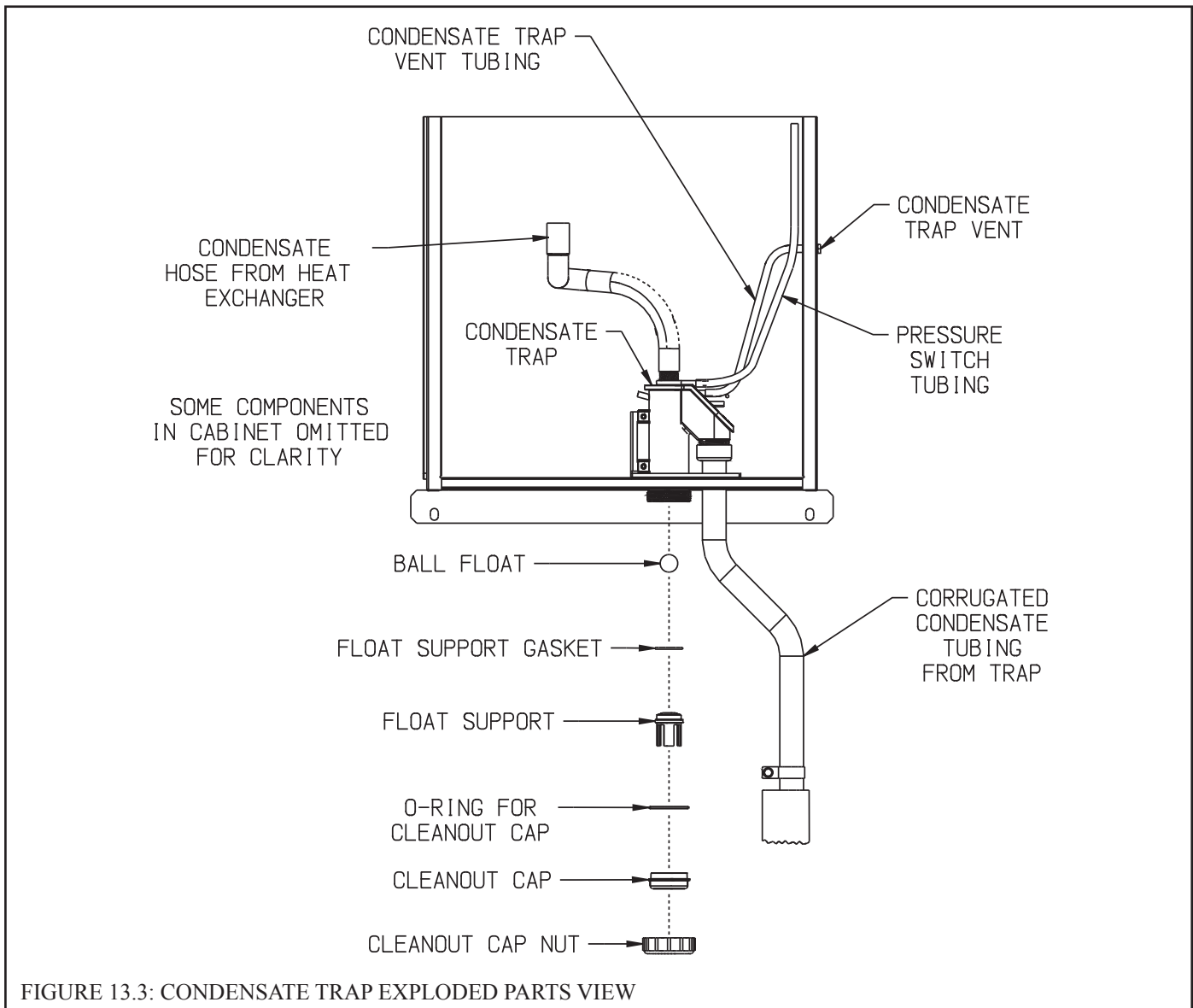

- t. **Replace any wiring** which has been disconnected.
- u. **Inspect the hydronic system.** Look for leaks and repair any found. If system contains antifreeze, or other additives, test and/or maintain them as directed by the additive manufacturer. See Part XI (Start-up and Checkout) for important information on boiler water and the use of boiler water additives.
- v. **Test the flow switch.** To do this:
 - Start with the boiler in standby.
 - Close a shut-off valve in the boiler loop.
 - Initiate a call for heat and confirm that the boiler shows Hold 137 indicating that the flow switch is open.

CAUTION

If burner comes on with no flow through the boiler, there is a problem with the flow switch. Turn the boiler off immediately. Failure to do so could cause severe heat exchanger damage.

- w. **Follow ALL instructions in Part XI (Start-up and Checkout)** to place the boiler back in service, including the performance of a combustion test.

XIV. Troubleshooting



DANGER

- **Explosion Hazard. Electrical Shock Hazard. Burn Hazard.** This boiler uses flammable gas, high voltage electricity, moving parts, and very hot water under high pressure. Assure that all gas and electric power supplies are off and that the water temperature is cool before attempting any disassembly or service.
- Do not attempt any service work if gas is present in the air in the vicinity of the boiler. Never modify, remove or tamper with any control device.



WARNING

- This boiler must only be serviced and repaired by skilled and experienced service technicians.
- If any controls are replaced, they must be replaced with identical models.
- Read, understand and follow all the instructions and warnings contained in all the sections of this manual.
- If any electrical wires are disconnected during service, clearly label the wires and assure that the wires are reconnected properly.
- Never jump out or bypass any safety or operating control or component of this boiler.
- Read, understand and follow all the instructions and warnings contained in ALL of the component instruction manuals.
- Assure that all safety and operating controls and components are operating properly before placing the boiler back in service.

The following pages contain information for use in diagnosing control problems. When using this information the following should be kept in mind:

- 1) This information is only meant to be used by a professional heating technician as an aid in diagnosing boiler problems.
- 2) Where applicable, follow all precautions outlined in the Section XI (Start-up and Checkout).
- 3) All controls on the boiler are tested at least once in the manufacturing process and a defective control or component is generally the least likely cause. Before replacing a component, try to rule out all other possible causes.

A. Using the Display to Troubleshoot

The display communicates problems in one of three ways, depending upon the nature of the problem:

Hold – A condition exists that, when cleared, will allow burner to automatically fire. This is similar to what is sometimes called a “soft lockout”, except that Holds also occur during normal operation (for example while the control is waiting for the fan to come up to the pre-purge speed). When a Hold is present, “Hold” is shown on the home screen as shown in Figure 14.0. If the Hold persists, the home screen will alternately flash the outlet temperature and the Hold Code as shown in Figure 14.1. A list of these codes, and their meanings, are shown in Table 14.4.

Lockout – An abnormal condition exists that, when cleared, will require manual reset of the control. When a Lockout is present, “Lockout” is shown on the home screen as shown in Figure 14.2 and the home screen will alternately flash the outlet temperature and the Lockout Code as shown. A list of these codes, and their meanings, are shown in Table 14.4. Codes used for Holds and Lockouts are the same and in some cases a hold condition that lasts long enough will become a Lockout. Lockouts can be cleared by either pressing the LH button as shown in Figure 14.3, or pressing the reset button on the control itself. The most recent Lockout can be seen, and cleared, on the “Lockout screen” shown in Figure 12.7 (interrupting power to the boiler also clears this history).

Alert – Not used in this application.

B. Troubleshooting when the Display is Blank

Use the flow chart in Figure 14.5 to locate the problem when the display is blank or is not readable.

C. Operation and Troubleshooting of Boiler Limits, Switches and Sensors

For the location of the controls described below, see Figure 14.6.

Thermal Fuse – The thermal fuse is designed to prevent boiler operation in the event that the heat exchanger is damaged by excessive flue gas temperatures. It is set to open at 358F and is a one shot non-replaceable device. If this fuse opens, the heat exchanger must be replaced. The thermal fuse is essentially a back-up to the flue gas sensor, which is designed to prevent boiler operation if the flue gas temperature exceeds 210F. Note, however, that it is possible for the thermal fuse to open even though the flue temperature limit is working properly. If the thermal fuse is suspected of having opened, unplug the wire heading to it and check continuity directly across the thermal fuse. If no continuity is present, the heat exchanger needs to be replaced. If continuity is present, the fault lies elsewhere.



WARNING

Asphyxiation Hazard. Fire Hazard. Do not attempt to jump or replace the thermal fuse. Doing so may cause a breach of the heat exchanger casing resulting in property damage, personal injury or loss of life.

Sump Pressure Switch (SPS) – This pressure switch is normally closed and monitors the difference in pressures between the boiler cabinet and the sump (the sump pressure is very close to the pressure at the boiler's vent connection). This switch is piped as shown in Figure 14.7. The SPS is calibrated to open at 3.15 +/- 0.10 inches water column. A blockage in vent system that causes the vent pressure to exceed the SPS set point will cause the burner to shut down and recycle. Likewise, a blockage in the air intake system that causes the vacuum in the cabinet to fall below -3.15 inches will also cause the boiler to shut down and recycle. If this switch opens, look for a blockage in the vent or air intake system.

Air Proving Switch (APS) – This pressure switch is normally open and is connected to the outlet tapping on the gas valve as shown in Figure 14.7. During pre-purge, when the gas valve is closed, the APS is monitoring the pressure drop across gas-air mixer (venturi for the 80-120, swirl plate on the 150 and 180). Greater air flow through the mixer causes this pressure reading to increase. The APS is calibrated to close when this pressure rises to 1.05 +/- 0.05" wc, which is a pressure at pre-purge corresponding to adequate air flow. After the gas valve opens, this pressure will drop very close to zero, regardless of the actual air flow rate through the boiler. For this reason, the APS is ignored after pre-purge. In the event that the burner fires continuously for two hours, the boiler control will recycle the burner to verify that the APS still closes and that adequate airflow is still present. If the APS opens, look for the following:

- Blockage in the vent or air intake system.
- Disconnected, loose or blocked APS tube.

Flow Switch – The paddle type flow switch is calibrated to close at a water flow rate of approximately 3.2GPM. This switch is intended to do two things:

- Prove that there is water in the boiler (no water means no flow at this switch)
- Prove that there is enough flow for the supply and return temperature sensors to accurately measure the water temperatures entering and exiting the heat exchanger.

The minimum flow rate required for all models is significantly above 3.2 GPM (Table 9.1). The boiler control verifies that there is adequate flow through the boiler by monitoring the temperature rise through the boiler; the flow switch merely assures that the measured rise is accurate. The boiler control starts to limit the firing rate when the temperature rise exceeds 53F and the boiler goes into a Hold if the rise reaches 63F. If the flow switch does not close, look for the following:

- No water in the boiler
- Trapped air in the boiler or system - make sure that a steady stream of water exits the manual air vent shown in Figure 11.1 when it is opened.
- Valve closed in boiler loop piping
- Fouled Y strainer in boiler loop piping

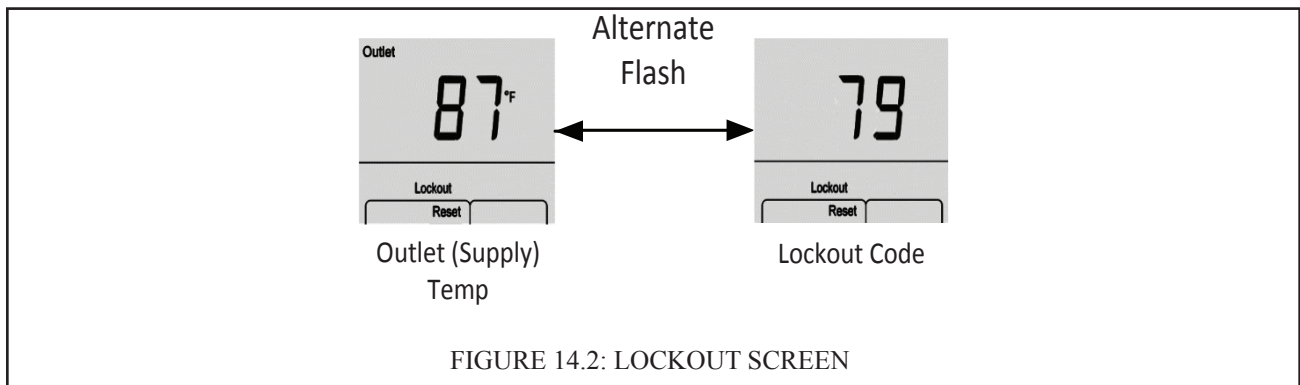
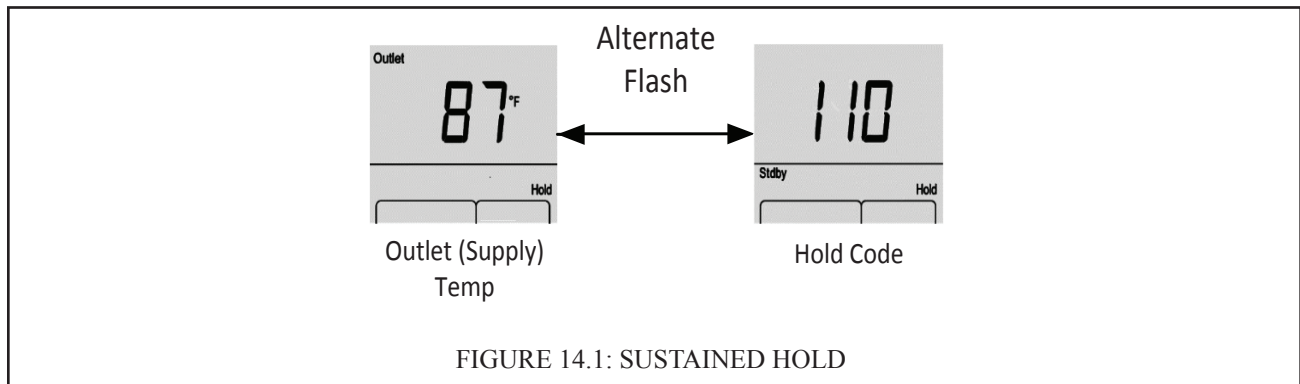
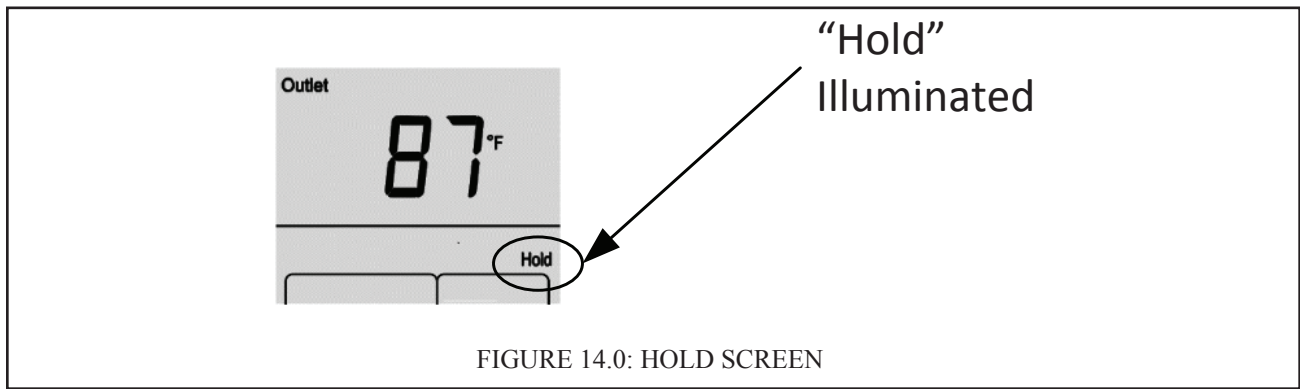

Supply Sensor – The boiler control infers the supply temperature based on the resistance measured at the supply sensor. Table 14.8a shows this resistance as a function of water temperature. Because the control/supply sensor is used as the boiler’s water temperature limit control, there are actually two “thermistors” in the supply sensor wired in parallel (Figure 10.5). The control compares the resistances across these two thermistors and prevents boiler operation if there is a significant difference between the readings.

Return Sensor – The boiler control infers the return temperature based on the resistance measured across a single thermistor in the return sensor. Table 14.8a shows this resistance as a function of water temperature.

Flue Temperature Sensor – The boiler control infers the flue gas temperature based on the resistance measured at the flue temperature sensor. Table 14.8a shows this resistance as a function of flue temperature. There are actually two “thermistors” in the flue temperature sensor wired in parallel (Figure 10.5). The control compares the resistances across these two thermistors and prevents boiler operation if there is a significant difference between the readings.

Outdoor Sensor – The boiler control infers the outdoor temperature based on the resistance measured across a single thermistor in the outdoor sensor. Table 14.8b shows this resistance as a function of temperature.

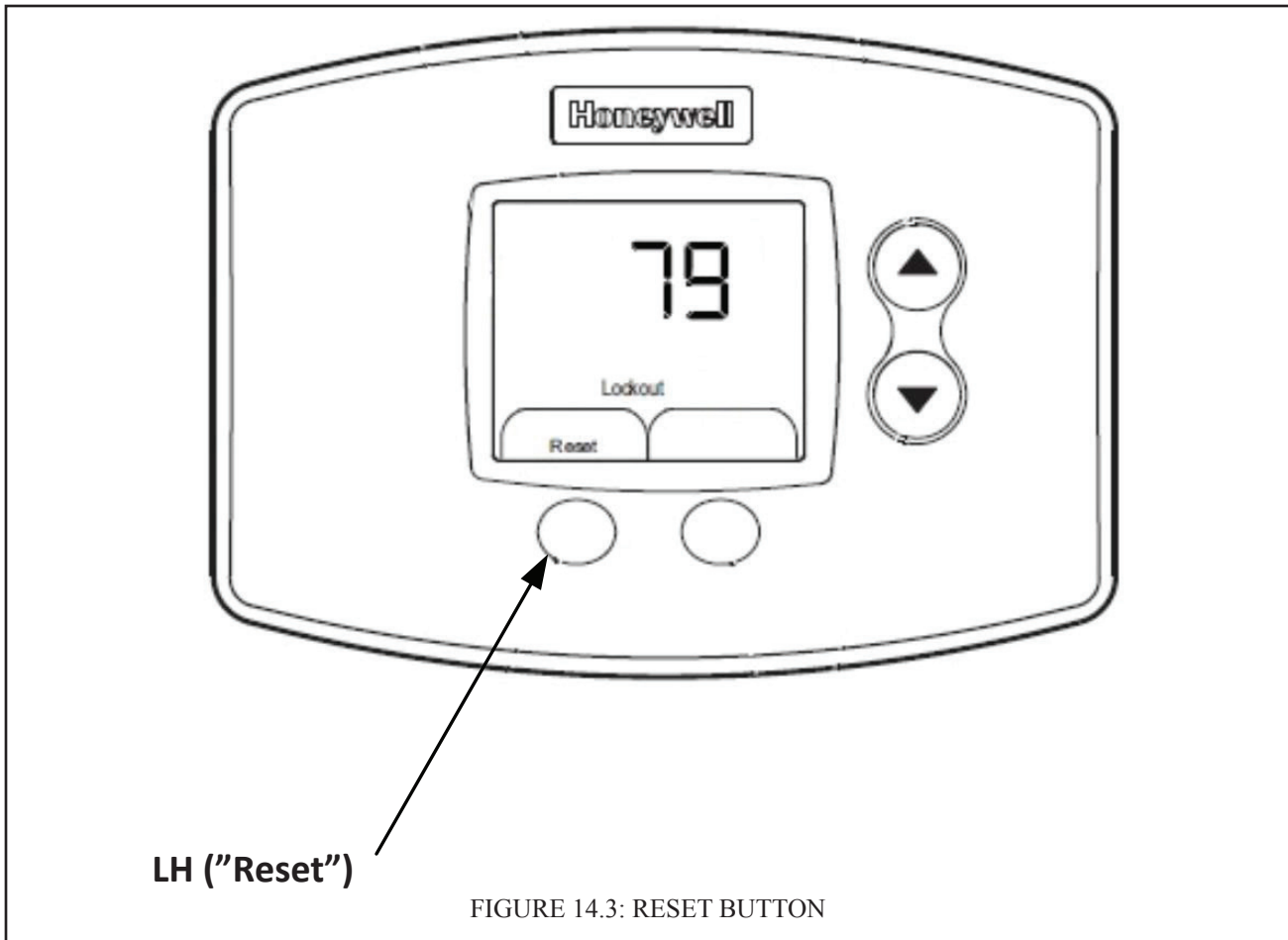

Condensate Trap – The condensate trap allows condensate to leave the boiler while containing flue gasses. In the event that this trap becomes blocked, condensate will start to back up in the trap. To prevent a rising condensate level from backing up into the heat exchanger, both a ground wire and the flame rod wire are bonded to this trap in such a way that an abnormally high condensate level will conduct flame current directly to ground (Figure 10.5). The boiler control will interpret this as a loss of flame and enter a Hold. See Figures 7.25 or 13.3 for trap location.

Combustion Fan – The combustion fan pushes air-fuel mixture into the burner and the speed of this blower determines the firing rate. There are two electrical connections at this fan:

- 120V Plug – Supplies 120VAC Power to the Fan
- Speed Control Plug - Delivers a PWM (speed control) signal from the boiler control to the fan. This plug also includes tachometer connections so that the boiler control can monitor the actual fan speed.

In the event that there is 120volts at the boiler, but no signal at the speed control plug, this fan will run at its maximum speed. Specific causes of this include:

- Disconnected speed control plug
- Loose J2 Plug
- Loose L2 or L3 Plug
- Defective 24V Transformer

Gas Valve – The gas valve used on this boiler has either one or two 24VDC coils (the gas valve used on all boiler models is redundant). The gas valve output from the boiler control is 24VAC. A rectifier module is installed between the gas valve and the wiring harness on the 80, 100 and 120 models (Figure 11.4a). The rectifier is built into the gas valve plug itself on the 150 and 180.

FIGURE 14.4: LOCKOUT/HOLD CODES

Code	Meaning	Possible Causes/Remedies
0	No hold or lockout present	
47	Flame rod to ground leakage	<ul style="list-style-type: none"> Damaged flame rod Blocked condensate drain Shorted or mis-wired flame rod wiring
49	Voltage supplied to control is outside of acceptable range.	<ul style="list-style-type: none"> Line voltage supply to boiler is outside acceptable range. Defective transformer Bad connection between transformer and control.
50	Control modulation parameters are incorrectly set.	If this is seen after restoration of parameters from PIM (Appendix C), attempt to restore a second time. If problem persists replace control.
61	Boiler is waiting for anti-short cycling (ASC) time to pass before starting ignition sequence.	Normal operation if anti-short cycle time (ASC) is not set to zero. Indicates that required time has not yet elapsed between last call for heat and this one. Boiler should respond to call for heat when this time has passed.
62	Waiting for fan to reach pre-purge/ignition speed.	Normal when fan is ramping up to pre-purge speed. Should clear after a few seconds.
63	One of the following limits is open: 1. Auxiliary limit 2. Thermal fuse 3. Sump pressure switch	<ul style="list-style-type: none"> Look for open external limit or, if none is installed, loose/missing external limit jumper Check continuity directly across thermal fuse and replace heat exchanger if none is present. Also see text. Blockage in vent or intake system.
65	Waiting for air proving switch to close during pre-purge	Normal Hold during pre-purge. Should clear after a few seconds.
66	Air proving switch (APS) is closed when it shouldn't be.	<ul style="list-style-type: none"> Jumped APS Defective or incorrect APS. Loose connection between terminal J2 and DC fan plug
67	Flow switch not closing.	<ul style="list-style-type: none"> Air in heat exchanger (bleed as shown in Figure 11.1) Inoperable boiler pump Undersized boiler pump Air in system Excessive pressure drop in boiler loop (P/S piping not used when it should be)
79	Supply water temperature exceeded 210F	<ul style="list-style-type: none"> Defective pump or inadequate boiler water flow (see causes for error code 67). Heating load far below boiler's minimum firing rate No flow through system loop
81	Temperature rise across boiler exceeded 63F	Inadequate water flow through boiler (see causes for Error code 67).
82	Flue gas temperature exceeded 214F	<ul style="list-style-type: none"> Dirty heat exchanger Incorrect air-fuel ratio Excessive firing rate.
85	Return temperature is higher than supply.	<ul style="list-style-type: none"> Boiler pump or connections to boiler are reversed. Supply/return sensor wiring reversed Supply or return sensor is defective
88	Supply temperature climbing too quickly.	<ul style="list-style-type: none"> See causes for error code 79
91	Inlet (return) sensor fault	<ul style="list-style-type: none"> Break in sensor wiring Short in sensor wiring Check for defective inlet sensor using the resistance table 14.8a.
92	Outlet (supply) sensor fault	<ul style="list-style-type: none"> Break in sensor wiring Short in sensor wiring Check for defective inlet sensor using the resistance table 14.8a.
95	Stack sensor fault	<ul style="list-style-type: none"> Break in sensor wiring Short in sensor wiring Check for defective inlet sensor using the resistance table 14.8a.
105	Flame signal detected when no flame should be present.	<ul style="list-style-type: none"> Defective gas valve (verify inlet pressure is less than 14.0" wc before replacing) Electrical noise.
110	Burner failed to light or flame not detected.	<ul style="list-style-type: none"> Gas valve switch turned off (80-120 only) Inadequate gas pressure Gas line not completely purged of air Incorrect air-fuel ratio (CO2) Loose gas valve connection Defective or dirty ignition/flame rod electrode Loose or defective ignition cable Loose flame rod connection Plugged condensate drain Loose burner ground connection Defective gas valve (check for 24VAC across red and yellow leads at gas valve plug during trial for ignition before replacing)
122, 123	Fan failed to reach correct ignition speed.	<ul style="list-style-type: none"> Loose or miswired fan harness Loose J2 Plug Loose connection in 120V fan wiring Defective fan
136	Air proving switch (APS) failed to close during last pre-purge.	<ul style="list-style-type: none"> Blockage in vent or intake system Abnormal air or flue gas restriction through boiler (e.g. fouled heat exchanger) Closed outlet tapping on gas valve Loose or blocked hose between APS and gas valve
137	Flow switch failed to close during last cycle.	<ul style="list-style-type: none"> See causes for error code 67
173, 177	Gas valve output error (power detected at control's gas valve output when none should be present)	Verify wiring is correct, then reset control. If problem persists replace control.
All other codes	Various	Reset control. If problem persists, replace control.

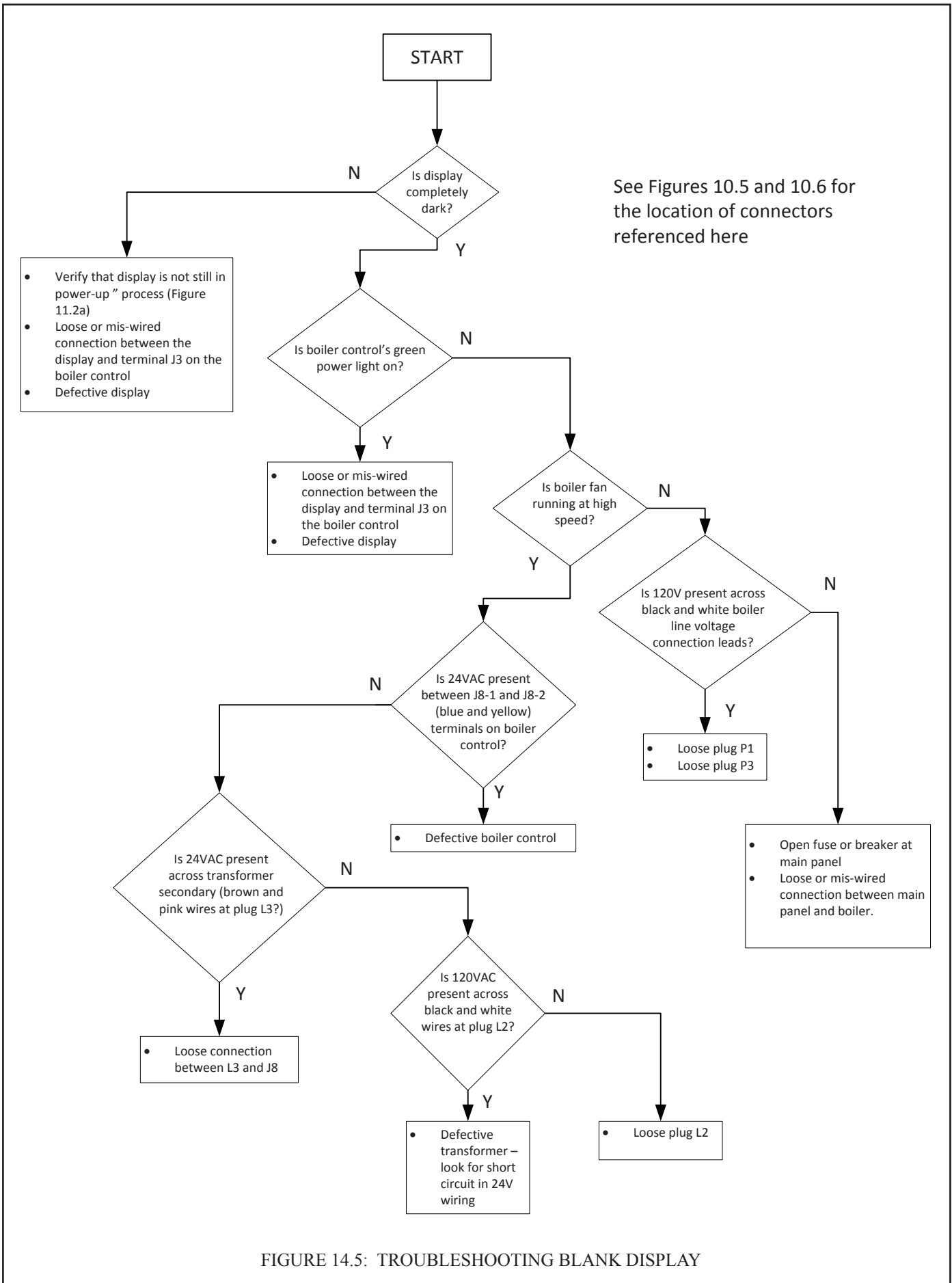
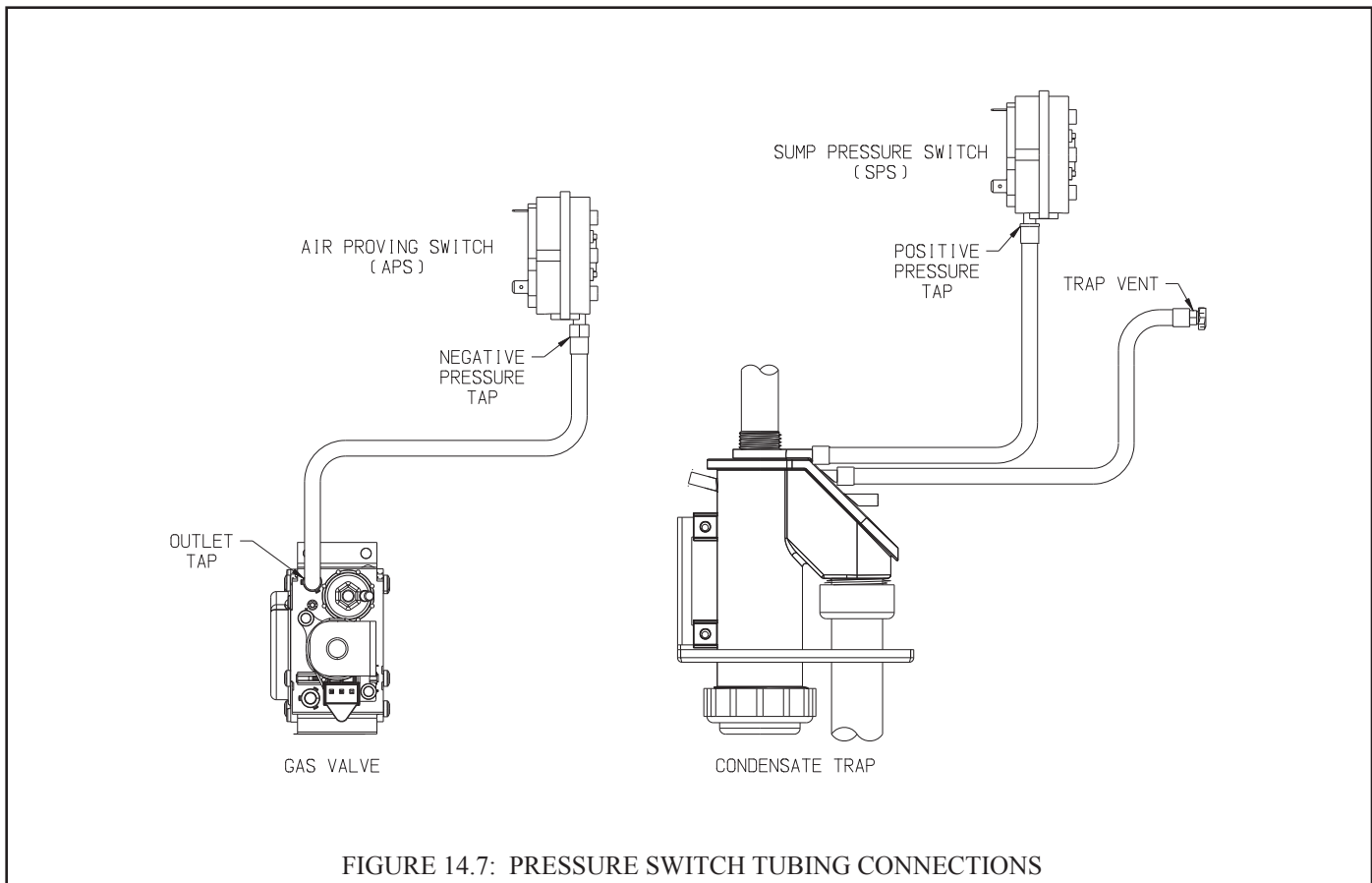
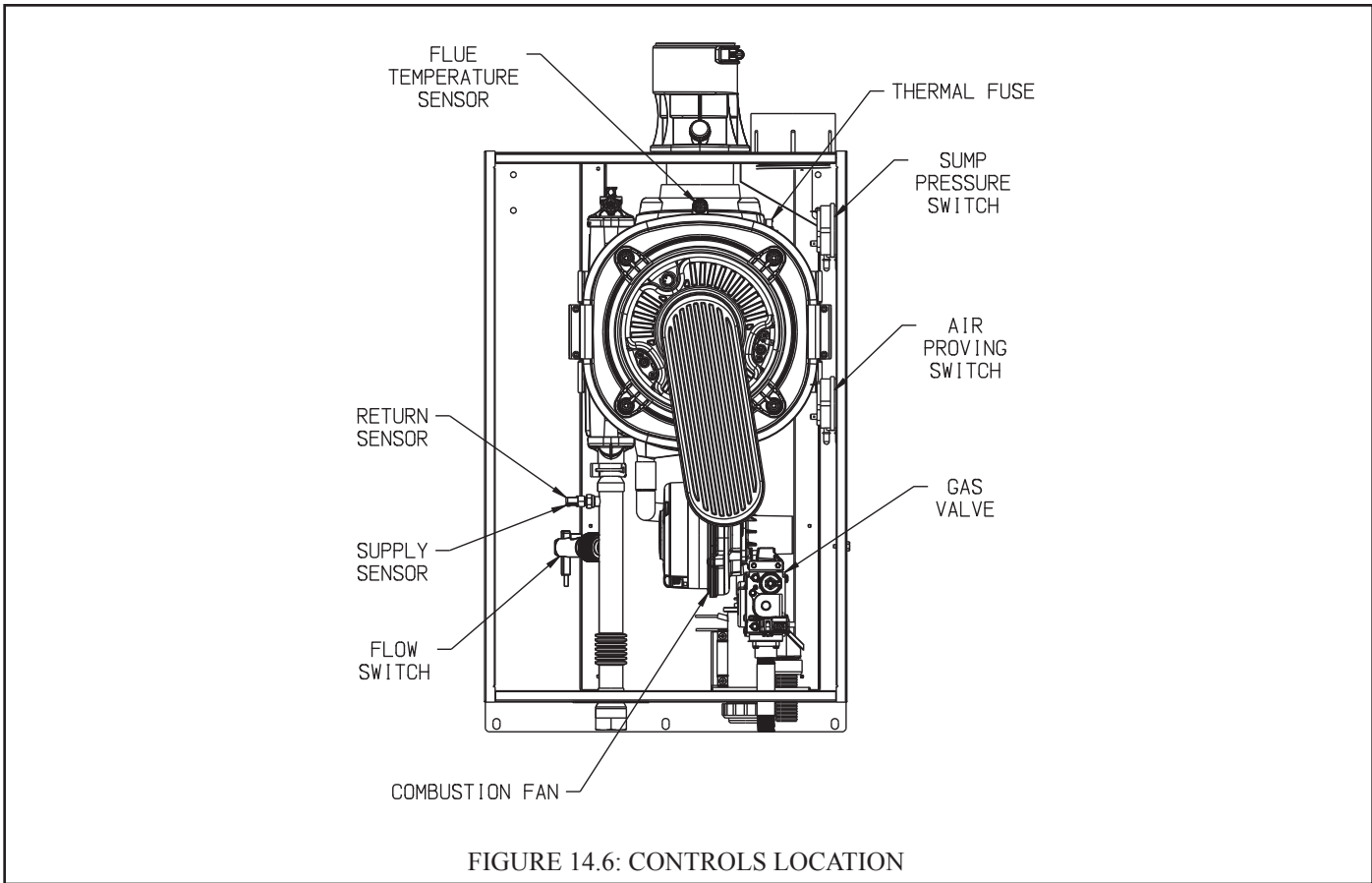

FIGURE 14.5: TROUBLESHOOTING BLANK DISPLAY



**Table 14.8a: Supply, Return and Flue
Temperature Sensor
Temperature versus Resistance**

Temperature		Ohms of Resistance
°F	°C	
32	0	32624
50	10	19897
68	20	12493
77	25	10000
86	30	8056
104	40	5324
122	50	3599
140	60	2483
158	70	1748
176	80	1252
194	90	912
212	100	674
230	110	506
248	120	384

**Table 14.8b: Outdoor Air Temperature Sensor
Temperature versus Resistance**

Outdoor Temperature		Ohms of Resistance
°F	°C	
-20	-28.9	106926
-10	-23.3	80485
0	-17.8	61246
10	-12.2	47092
20	-6.7	36519
30	-1.1	28558
40	4.4	22537
50	10.0	17926
60	15.6	14356
70	21.1	11578
76	24.4	10210
78	25.6	9795
80	26.7	9398
90	32.2	7672
100	37.8	6301
110	43.3	5203
120	48.9	4317

XV Parts

All Shadow Series Repair Parts may be obtained through your local Velocity Boiler Works Wholesale distributor. Should you require assistance in locating a Velocity Boiler Works Distributor in your area, or you have questions regarding the availability of Velocity Boiler Works products or repair parts, please contact Velocity Boiler Works Customer Service at (215) 535-8900 or Fax (215) 535-9736 or at www.velocityboilerworks.com

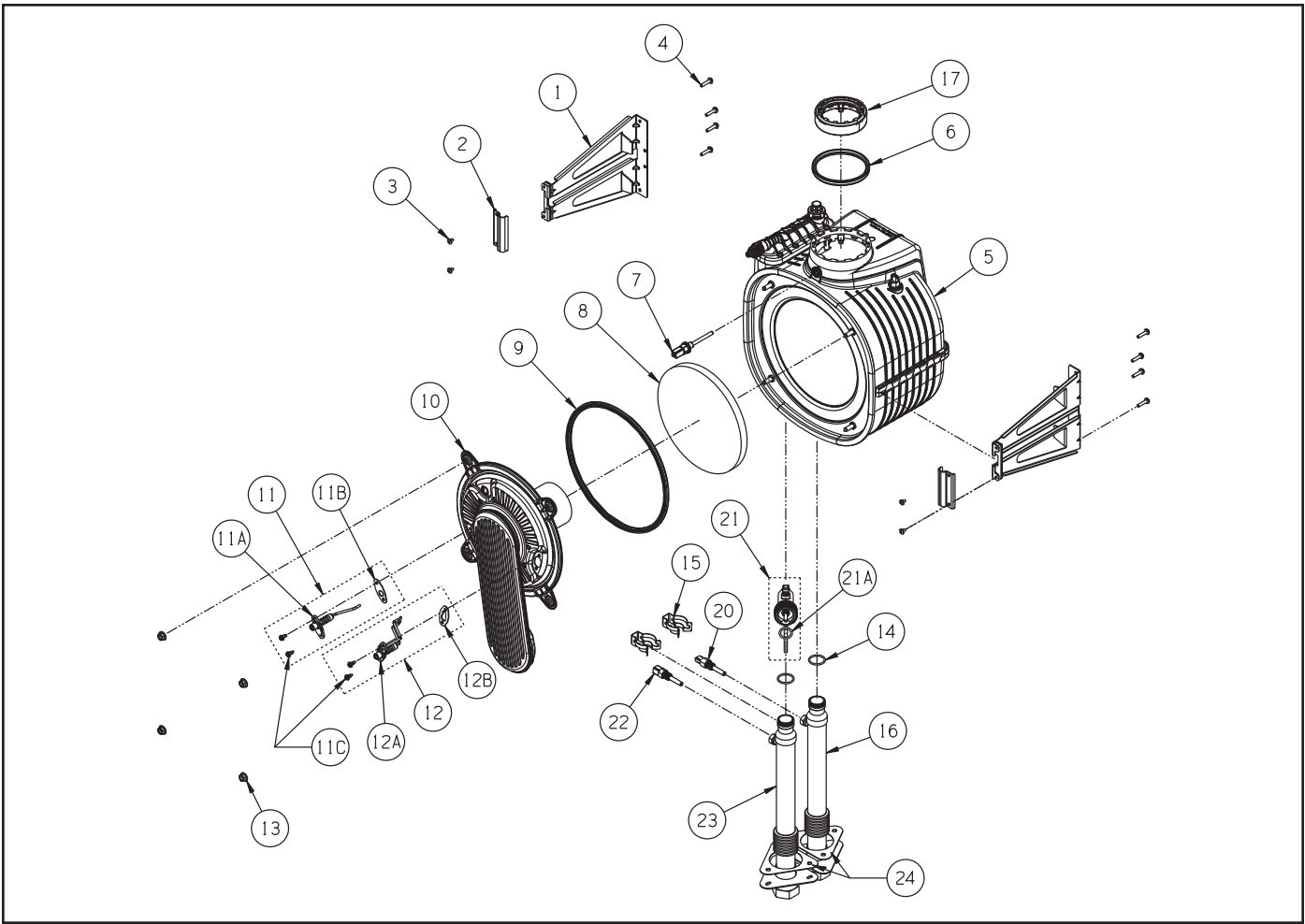

KEY #	DESCRIPTION	QTY. OR PN	QUANTITY OR PART NUMBER				
			80	100	120	150	180
1	FIXING CLAMP BRACKET		CONTACT FACTORY; PROVIDE BOILER SERIAL NUMBER				
2	HOLDING CLAMP						
3	M4 x 7 FIXING CLAMP SCREW						
4	#10-32 X 1/2" THREAD CUTTING SCREW						
5	BARE HEAT EXCHANGER						
6	FLUE OUTLET GASKET	105882-01	1 EA	1 EA	1 EA	1 EA	1 EA
7	FLUE TEMPERATURE SENSOR REPAIR KIT	105883-01	1 EA	1 EA	1 EA	1 EA	1 EA
8	REAR TARGET WALL INSULATION REPAIR KIT	105651-01	1 EA	1 EA	1 EA	1 EA	1 EA
9	COLD BURNER DOOR BLACK OUTER GASKET REPAIR KIT	106030-01	1 EA	1 EA	1 EA	1 EA	1 EA
10	COLD BURNER DOOR ASSEMBLY REPAIR KIT	1 EA	105875-01	105875-01	105875-01	105875-01	105875-01
11A, 11B, 11C	FLAME ROD REPAIR KIT (includes flame rod, gasket and hardware)	105880-01	1 EA	1 EA	1 EA	1 EA	1 EA
12A, 12B, 11c	IGNITION ELECTRODE REPAIR KIT (includes electrode, gasket and hardware)	105881-01	1 EA	1 EA	1 EA	1 EA	1 EA
13	M6 SERRATED FLANGE HEX BURNER DOOR NUT	101724-01	4 EA	4 EA	4 EA	4 EA	4 EA
14, 15	O-RING REPAIR KIT (includes (2) 22mm x 2mm O-rings and (2) connection clips)	105888-01	1 EA	1 EA	1 EA	1 EA	1 EA
14, 15, 16, 24	REPAIR RETURN PIPING ASSEMBLY KIT	107155-01	1 EA	1 EA	1 EA	1 EA	1 EA
17	80 x 60mm FLUE OUTLET ADAPTER	106885-01	1 EA	1 EA			
20	RETURN TEMPERATURE SENSOR REPAIR KIT	105910-01	1 EA	1 EA	1 EA	1 EA	1 EA
21	FLOW SWITCH REPAIR KIT (includes flowswitch with O-ring)	105892-01	1 EA	1 EA	1 EA	1 EA	1 EA
22	SUPPLY TEMPERATURE SENSOR REPAIR KIT	105911-01	1 EA	1 EA	1 EA	1 EA	1 EA
12, 15, 23, 24	REPAIR SUPPLY PIPING ASSEMBLY KIT	107157-01	1 EA	1 EA	1 EA	1 EA	1 EA

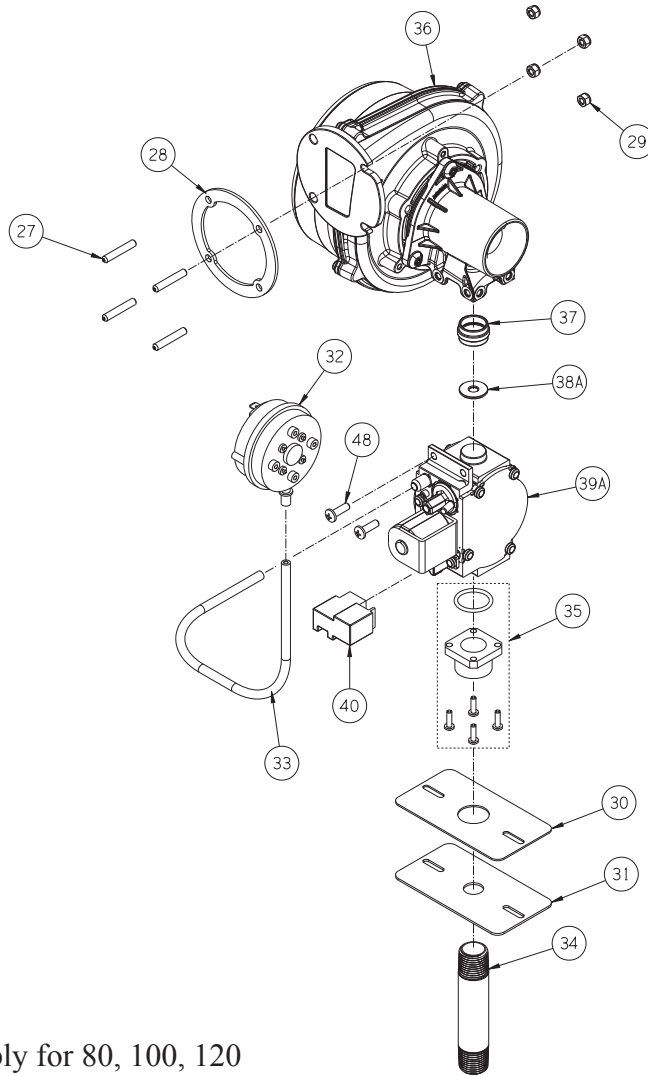

Blower/Gas Valve Assembly for 80, 100, 120

KEY #	DESCRIPTION	QTY. OR PN	QUANTITY OR PART NUMBER				
			80	100	120	150	180
27, 28, 29, 36	BLOWER REPAIR KIT (includes blower, hardware and gasket)	1 EA	105809-01	105809-01	105810-01	105811-01	105811-01
28	BLOWER OUTLET GASKET REPAIR KIT	106029-01	1 EA	1 EA	1 EA	1 EA	1 EA
30	GAS LINE SEAL REPAIR KIT (includes gas line escutcheon plate, gasket and hardware)	107151-01	1 EA	1 EA	1 EA	1 EA	1 EA
32	AIR PROVING PRESSURE SWITCH REPAIR KIT	105849-01	1 EA	1 EA	1 EA	1 EA	1 EA
33, 54, 57, 59, 60	TUBING REPAIR KIT	107156-01	1 EA	1 EA	1 EA	1 EA	1 EA
34A	1/2"NPT X 4" SCH 40 STEEL NIPPLE	OBTAIN LOCALLY	1 EA	1 EA	1 EA		
34B	1/2"NPT X 5" SCH 40 STEEL NIPPLE	OBTAIN LOCALLY				1 EA	1 EA
35	GAS VALVE FLANGE REPAIR KIT	106887-01	1 EA	1 EA	1 EA	1 EA	1 EA
37, 38A, 39A, 40	GAS VALVE REPAIR KIT, 80-120 (includes gas valve, gas orifice, rubber coupling, rectifier module and hardware)	105812-01	1 EA	1 EA	1 EA		
38B, 39B, 43	GAS VALVE REPAIR KIT, 150, 180 (includes gas valve, gas orifice, rubber coupling, rectifier module and hardware)	105813-01				1 EA	1 EA
40	RECTIFIER MODULE, E BOX 2	105829-01	1 EA	1 EA	1 EA		
42	BLOWER INLET SHROUD ASSEMBLY KIT	1 EA				105832-01	105833-01
45	ATTENUATOR ASSEMBLY	105234-01				1 EA	1 EA
46	8-18 X 3/4 SELF DRILLING SCREW	80860716				1 EA	1 EA

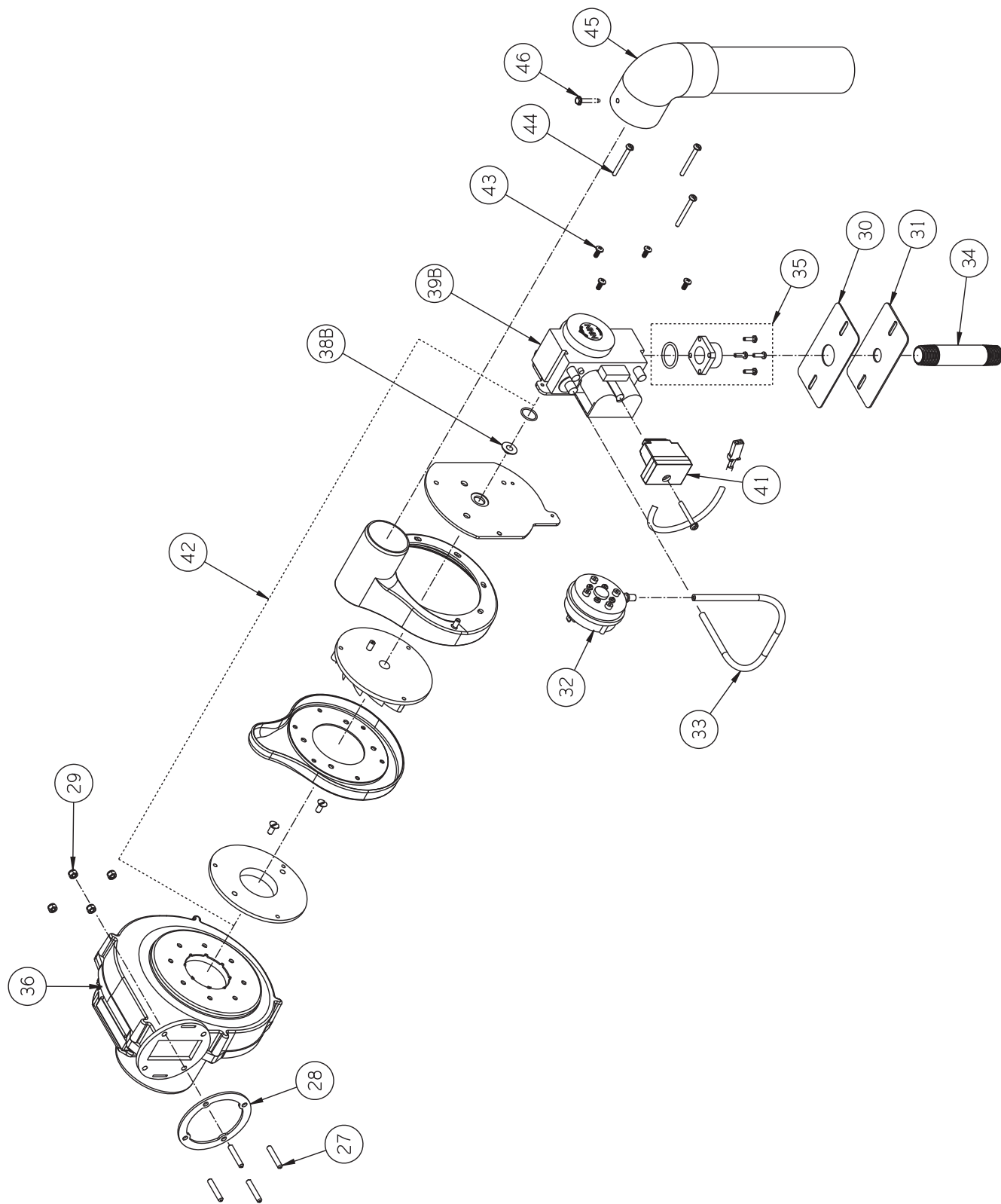

Blower/Gas Valve Assembly for 150, 180

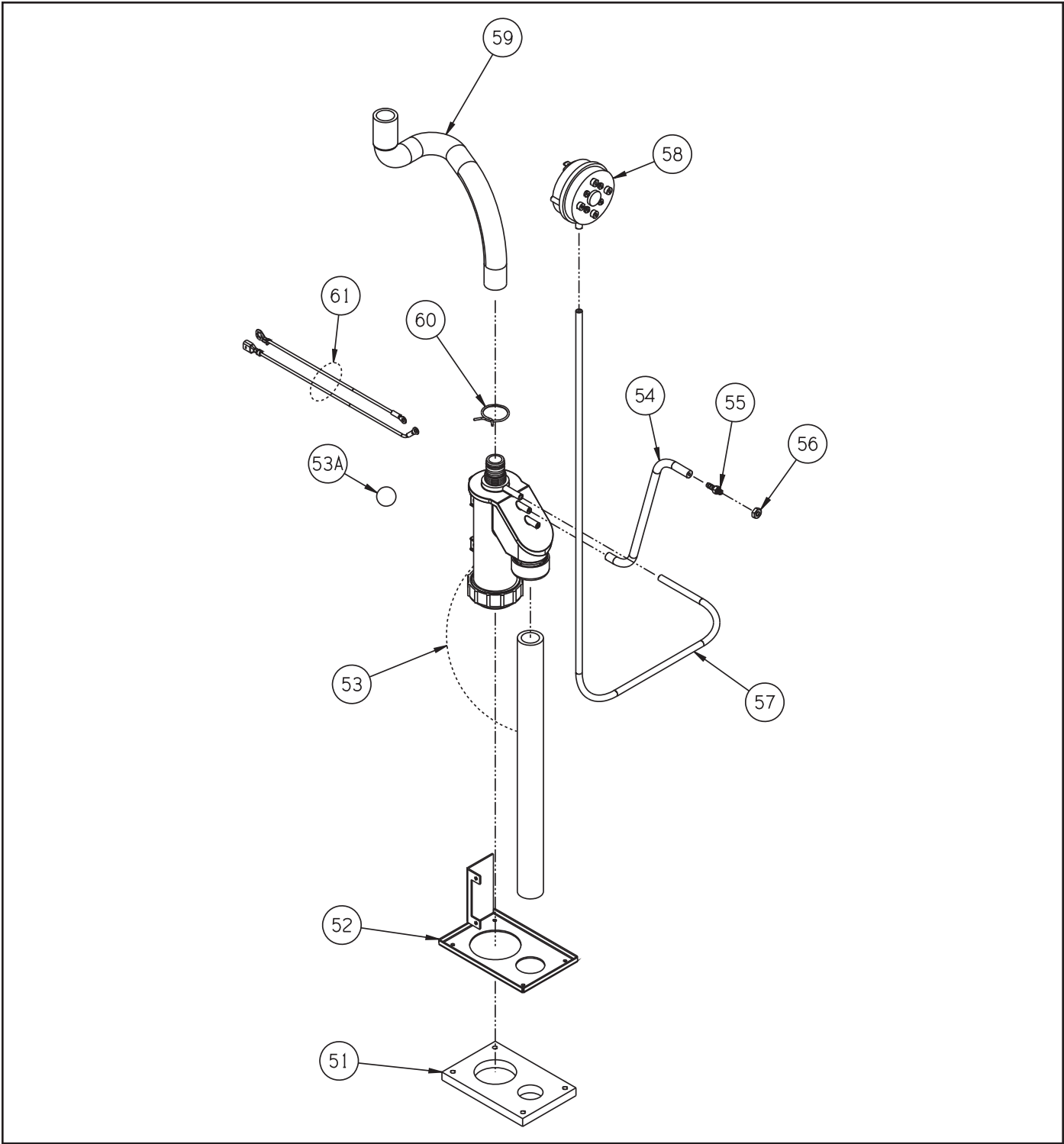

KEY #	DESCRIPTION	QTY. OR PN	QUANTITY OR PART NUMBER				
			80	100	120	150	180
51, 52, 53, 54, 57, 59, 60, 61	CONDENSATE TRAP REPAIR KIT (includes trap, trap ball, bracket, tubing, gasket, trap wires and hardware)	107144-01	1 EA	1 EA	1 EA	1 EA	1 EA
53A	BALL FOR CONDENSATE TRAP REPAIR KIT	105850-01	1 EA	1 EA	1 EA	1 EA	1 EA
55, 56	VENT FITTING REPAIR KIT (includes hose barb and nut)	105859-01	1 EA	1 EA	1 EA	1 EA	1 EA
33, 54, 57, 59, 60	TUBING REPAIR KIT	107156-01	1 EA	1 EA	1 EA	1 EA	1 EA
58	SUMP PRESSURE SWITCH REPAIR KIT	105857-01	1 EA	1 EA	1 EA	1 EA	1 EA
61	TRAP HARNESS KIT	107159-01	1 EA	1 EA	1 EA	1 EA	1 EA

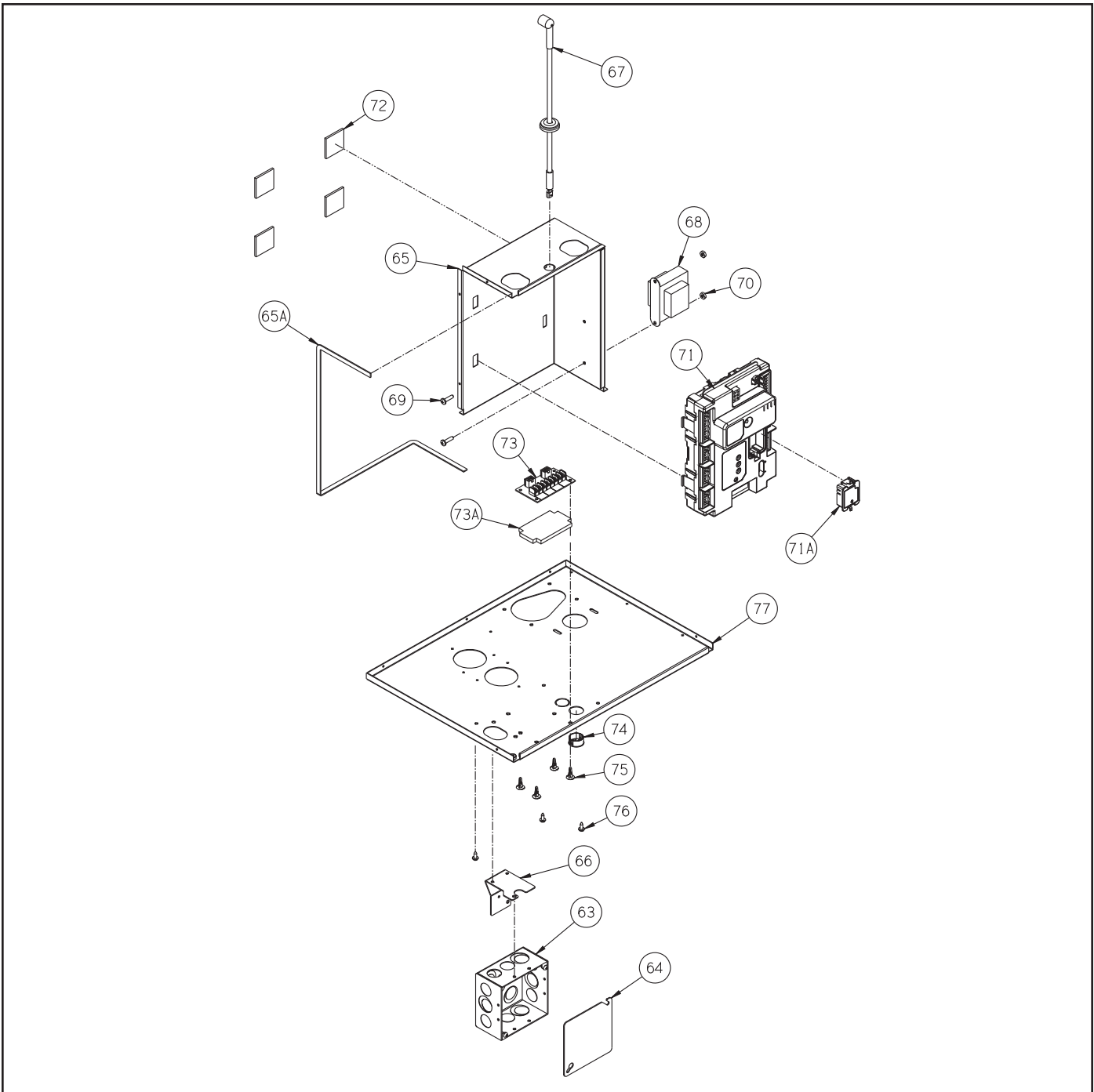

KEY #	DESCRIPTION	QTY. OR PN	QUANTITY OR PART NUMBER				
			80	100	120	150	180
63, 64, 66, 131	JUNCTION BOX ASSY (includes j-box, j-box mounting bracket, line voltage field connection harness and hardware)	107154-01	1 EA	1 EA	1 EA	1 EA	1 EA
65	CONTROL BOX	106723-01	1 EA	1 EA	1 EA	1 EA	1 EA
65A	CONTROL BOX GASKET	106838-01	1 EA	1 EA	1 EA	1 EA	1 EA
67	IGNITION CABLE REPAIR KIT	107152-01	1 EA	1 EA	1 EA	1 EA	1 EA
68	TRANSFORMER REPAIR KIT	106034-01	1 EA	1 EA	1 EA	1 EA	1 EA
71	REPLACEMENT CONTROL KIT, SHADOW	107097-01	1 EA	1 EA	1 EA	1 EA	1 EA
71A	PIM KIT	1 EA	107165-01	107165-02	107165-03	107165-04	107065-05
72	CONTROL GASKET KIT (includes 4 gaskets)	107143-01	4 EA	4 EA	4 EA	4 EA	4 EA
73, 73A, 75	LOW VOLTAGE PRINTED CIRCUIT BOARD REPAIR KIT (includes low voltage pcb and hardware)	107141-01	1 EA	1 EA	1 EA	1 EA	1 EA
77	BOTTOM PANEL	1 EA	106726-01	106726-02	106726-03	106829-01	106829-01

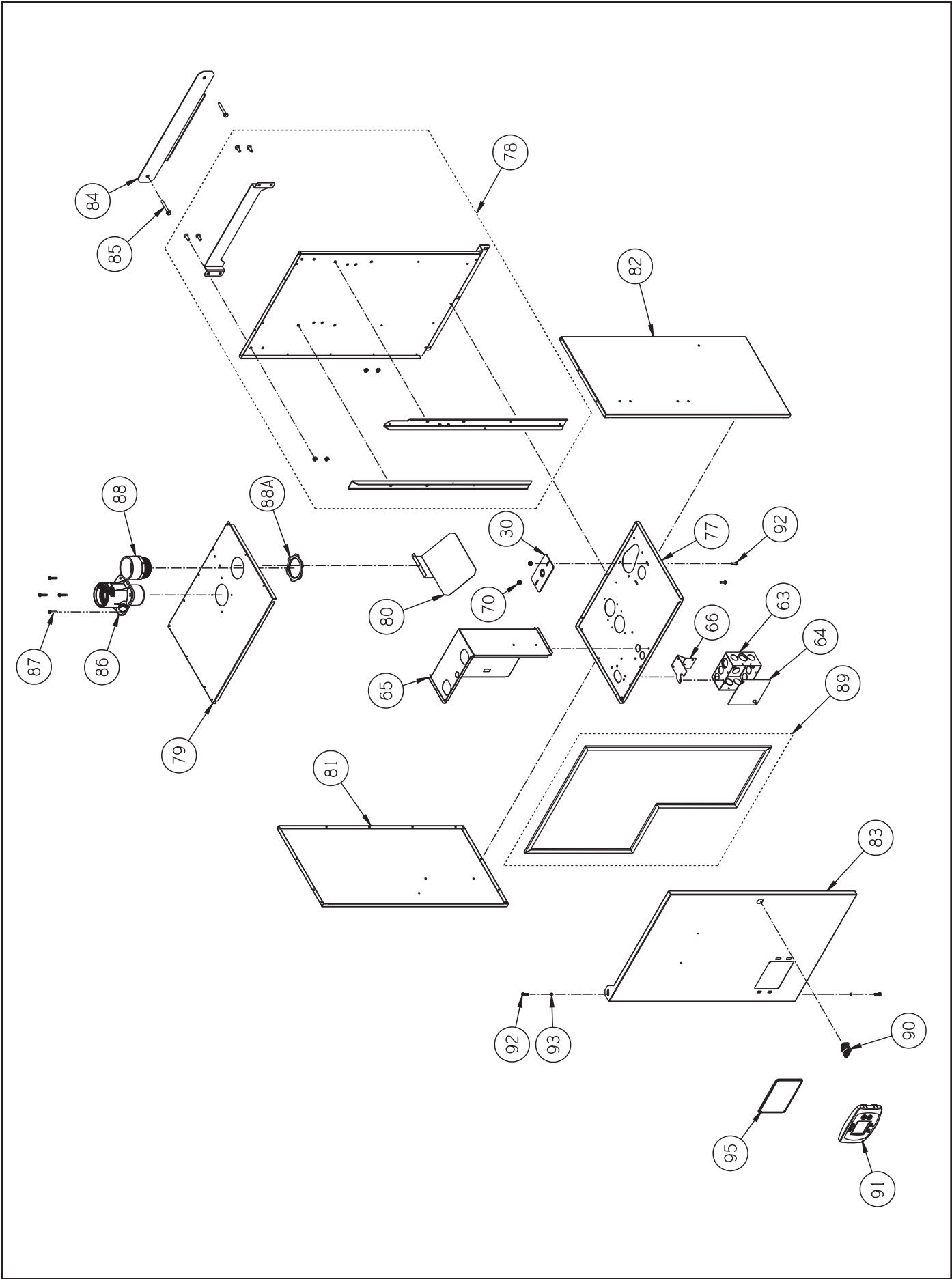

KEY #	DESCRIPTION	QTY. OR PN	QUANTITY OR PART NUMBER				
			80	100	120	150	180
63, 64, 66, 131	JUNCTION BOX ASSY (includes j-box, j-box mounting bracket, line voltage field connection harness and hardware)	107154-01	1 EA	1 EA	1 EA	1 EA	1 EA
65	CONTROL BOX	106723-01	1 EA	1 EA	1 EA	1 EA	1 EA
77	BOTTOM PANEL	1 EA	106726-01	106726-02	106726-03	106829-01	106829-01
78	REAR PANEL ASSEMBLY	1 EA	106733-01	106733-01	106733-01	106836-01	106836-01
79	TOP PANEL REPAIR KIT	1 EA	107158-01	107158-01	107158-02	107158-03	107158-03
80	JACKET DRIP SHIELD, 80-180	106724-01	1 EA	1 EA	1 EA	1 EA	1 EA
81	LEFT SIDE PANEL	1 EA	106849-01	106849-01	106849-01	106849-02	106849-02
82	RIGHT SIDE PANEL	1 EA	106850-01	106850-01	106850-01	106850-02	106850-02
83	DOOR REPAIR KIT	1 EA	107150-01	107150-01	107150-01	107150-02	107150-02
84	HANGING BRACKET, WALL	102869-01	1 EA	1 EA	1 EA	1 EA	1 EA
85	5/16" X 2" LAG SCREW/WASHER	OBTAIN LOCALLY	4 EA	4 EA	4 EA	4 EA	4 EA
6, 17, 86, 87	VENT ADAPTER REPAIR KIT	1 EA	107160-01	107160-01	107161-01	107161-01	107161-01
88	INTAKE REPAIR KIT	1 EA	107153-01	107153-01	105848-01	105848-01	105848-01
89	DOOR GASKET REPAIR KIT	1 EA	107148-01	107148-01	107148-01	107148-02	107148-02
90, 92, 93	DOOR HARDWARE REPAIR KIT	1 EA	107147-01	107147-01	107147-01	107147-01	107147-01
91	DISPLAY REPAIR KIT	1 EA	107146-01	107146-01	107146-01	107146-01	107146-01
95	LOGO PLATE, SHADOW	103384-26	1 EA	1 EA	1 EA	1 EA	1 EA

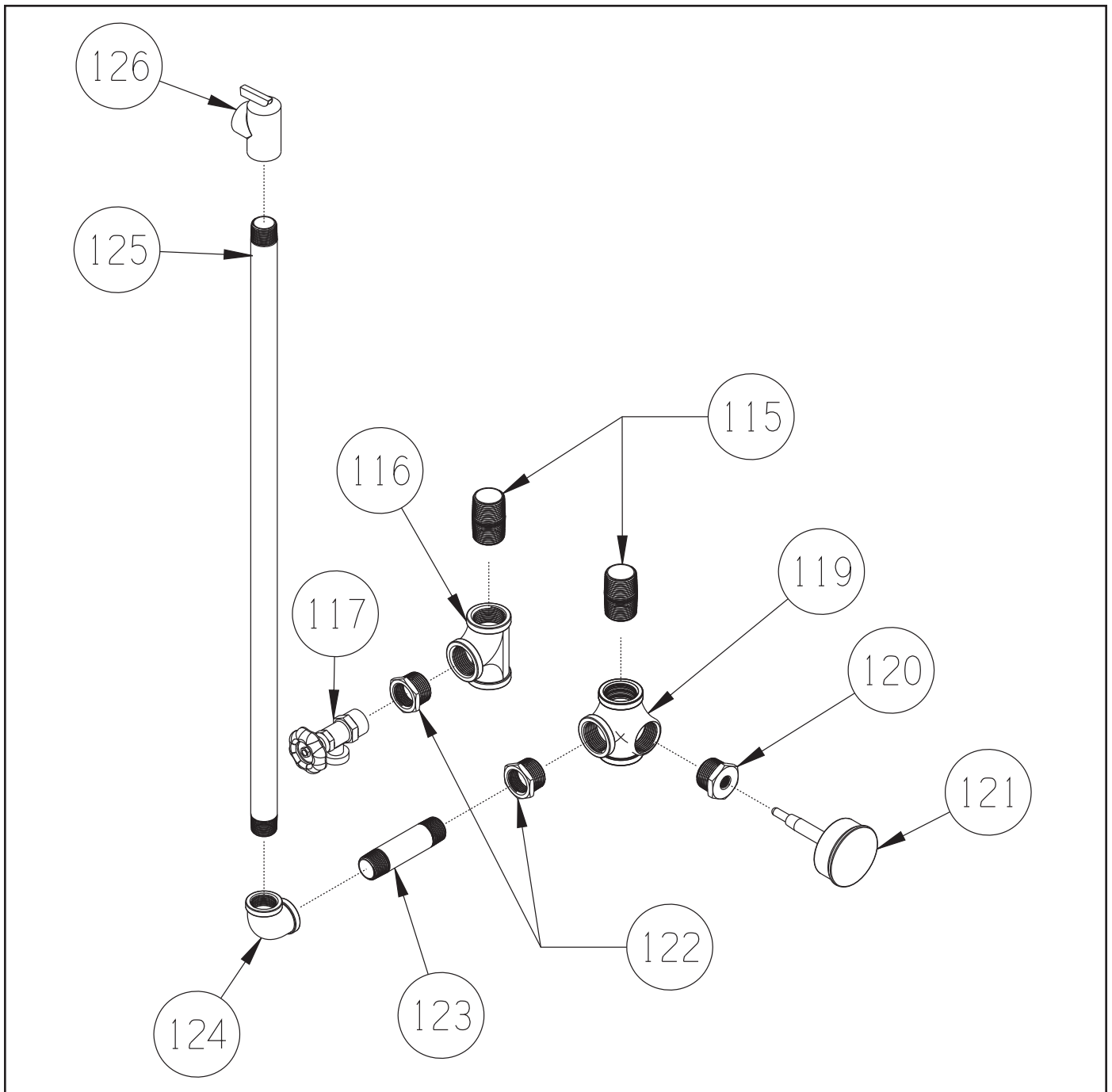

KEY #	DESCRIPTION	QTY. OR PN	QUANTITY OR PART NUMBER				
			80	100	120	150	180
115	1"NPT x 2" NIPPLE	80600004	2 EA	2 EA	2 EA	2 EA	2 EA
116	1" NPT TEE	806601015	1 EA	1 EA	1 EA	1 EA	1 EA
117	3/4" NPT BOILER DRAIN VALVE	806603061	1 EA	1 EA	1 EA	1 EA	1 EA
119	1" NPT TEE WITH SIDE OUTLET	105298-01	1 EA	1 EA	1 EA	1 EA	1 EA
120	1" x 1/4" NPT HEX REDUCING BUSHING	806600529	1 EA	1 EA	1 EA	1 EA	1 EA
121	TEMPERATURE & PRESSURE GAUGE REPAIR KIT	105894-01	1 EA	1 EA	1 EA	1 EA	1 EA
122	1" x 3/4" NPT HEX REDUCING BUSHING	806600501	2 EA	2 EA	2 EA	2 EA	2 EA
123	3/4" NPT X 5-1/2" NIPPLE	107053-01	1 EA	1 EA	1 EA		
	3/4" NPT X 7" NIPPLE	806600195				1 EA	1 EA
124	3/4" NPT 90° ELBOW	806601502	1 EA	1 EA	1 EA	1 EA	1 EA
125	3/4" NPT X 30" NIPPLE	105297-01	1 EA	1 EA	1 EA	1 EA	1 EA
126	30 psi RELIEF VALVE	81660319	1 EA	1 EA	1 EA	1 EA	1 EA

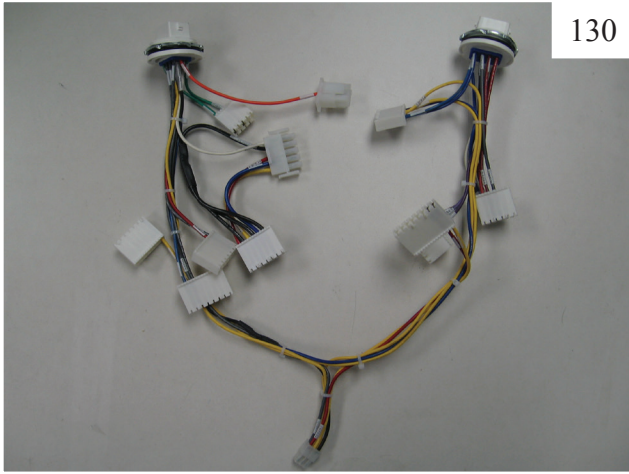

130

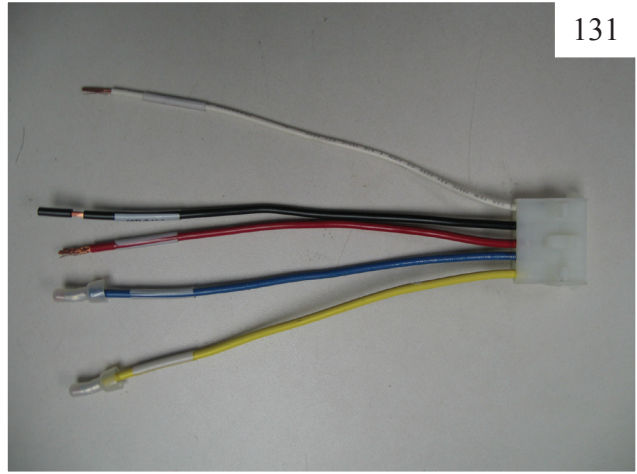

131

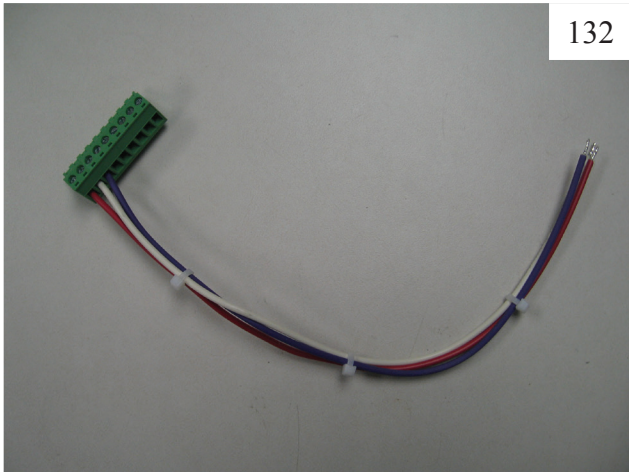

132

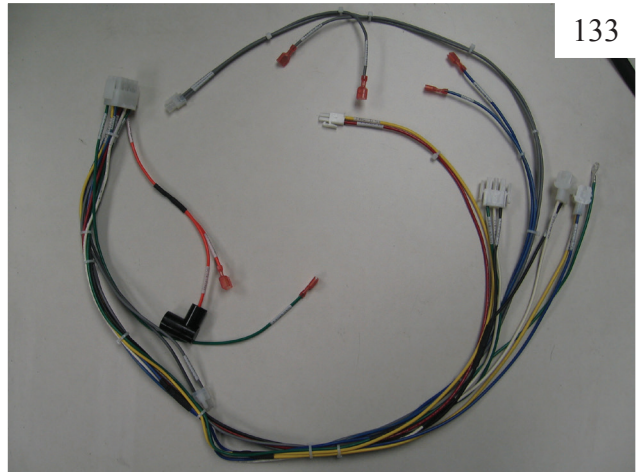

133

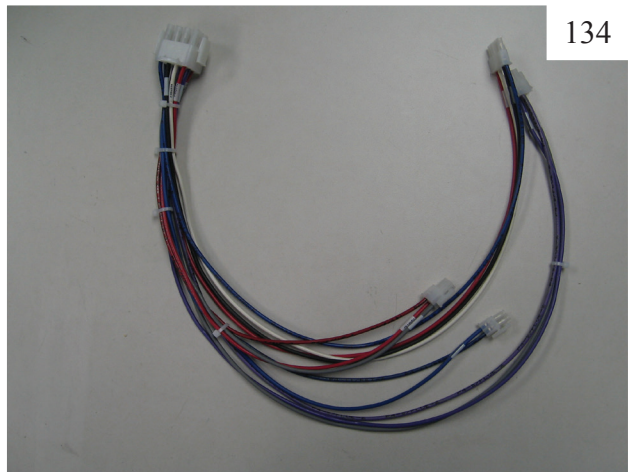

134

KEY #	DESCRIPTION	QTY. OR PN	QUANTITY OR PART NUMBER				
			80	100	120	150	180
130	REPAIR KIT, CONTROL BOX HARNESS	107142-01	1 EA	1 EA	1 EA	1 EA	1 EA
131	REPAIR KIT, 120V FIELD CONNECTIONS HARNESS	107139-01	1 EA	1 EA	1 EA	1 EA	1 EA
132	REPAIR KIT, DISPLAY HARNESS	107149-01	1 EA	1 EA	1 EA	1 EA	1 EA
133	REPAIR KIT, INTERIOR AC HARNESS	1 EA	107140-01	107140-01	107140-01	107140-02	107140-02
134	REPAIR KIT, INTERIOR DC HARNESS	107145-01	1 EA	1 EA	1 EA	1 EA	1 EA
*	OUTDOOR TEMPERATURE SENSOR	102946-01	1 EA	1 EA	1 EA	1 EA	1 EA

* NOT SHOWN

Appendix A: Instructions for Conversion of This Boiler for Use with LP Gas



DANGER

These instructions include a procedure for adjusting the air-fuel mixture on this boiler. This procedure requires a combustion analyzer to measure the CO₂ and Carbon Monoxide (CO) levels in flue gas. Adjusting the air-fuel mixture without a proper combustion analyzer could result in unreliable boiler operation, personal injury, or death due to carbon monoxide poisoning.



WARNING

- **LP CONVERSIONS** - This conversion shall be performed by a qualified service agency in accordance with the manufacturer's instructions and all applicable codes and requirements of the authority having jurisdiction. If the information in these instructions is not followed exactly, a fire, an explosion or production of carbon monoxide may result causing property damage, personal injury, or loss of life. The qualified service agency is responsible for proper conversion of this boiler. The installation is not proper and complete until the operation of the converted appliance is checked as specified in the instructions below.

All boilers listed in this manual are factory configured for use on Natural gas at altitudes at or below 2000 feet. Perform the steps listed in these instructions to convert it for use with LP gas.

- 1) If not already done, install the boiler in accordance with this manual, following all instructions in Part XI (Start-up and Check-out) up to Step 10.
- 2) Set the throttle to its preliminary setting for LP. To do this:
 - a. Turn the throttle (Figure A.1) clockwise until it stops (several full turns).
 - b. Turn throttle counter-clockwise the exact number of turns shown in Table A.2.
- 3) Attempt to start the boiler using the lighting instructions located on Page 60. If the boiler does not light on the first try for ignition, allow to boiler to make at least four more attempts to light. If boiler still does not light, turn the throttle counterclockwise in 1/8 turn increments, allowing the boiler to make at least four tries for ignition at each setting, until the boiler lights.
- 4) After the burner lights, force the burner to high fire by entering the Diagnostics Menu, and selecting Manual Input, then "HF" as described in Part XI (start-up and checkout). Allow the boiler to operate for approximately 5 minutes before taking combustion readings. Note: that after 15 minutes, boiler is automatically released from high fire hold. The boiler will also be released from manual input if the user manually navigates back to the home screen.
- 5) Perform a combustion test, sampling flue products from the tap in the front of the vent adaptor.
- 6) While the burner is at high fire adjust the throttle as needed to obtain the CO₂ settings shown in the Table A.3:
 - To reduce the CO₂ (increase the O₂) turn the throttle clockwise
 - To increase the CO₂ (reduce the O₂) turn the throttle counter-clockwise

Make adjustments in increments of 1/8 to 1/4 turn and allow the boiler at least a minute to respond to each adjustment before making another. In general, the CO level will be at its lowest somewhere in the CO₂ range shown in this table. Consult factory if it is not possible to reduce the CO level below 200PPM air free within the range of CO₂s shown for the fuel and altitude at which the boiler is being used.



WARNING

- **The throttle adjustments shown in Table A.2 are approximate. The final throttle setting must be found using a combustion analyzer. Leaving the boiler in operation with a CO level in excess of 200PPM air-free could result in injury or death from carbon monoxide poisoning. Leaving the boiler in operation with a CO₂ level outside of the range shown in Table A.3 could also result in injury or death from carbon monoxide poisoning, even if the boiler is operating at an air-free CO level below 200PPM during this adjustment procedure.**
- **If the throttle is very far out of adjustment on the “rich” (counter-clockwise) side, the boiler burner may be running at 0% excess air or even with air deficiency. Operating the boiler in this condition may cause property damage, personal injury or loss of life. Under these conditions most combustion analyzers used in the field will show 0% O₂ and a very high (well over 1000 ppm) CO. Combustion readings will also appear to be unresponsive to throttle adjustment. If the boiler appears to be operating under this condition, turn the throttle screw clockwise until the flame lengthens significantly and is mostly blue. Then, slowly turn the throttle counter-clockwise, using a combustion analyzer to achieve the required CO₂ as described in Step 6.**

- 7) Replace the screw cap in the vent adapter when combustion testing is complete.
- 8) Cycle boiler at least five times at the final throttle setting to ensure burner ignites without delay and without noise.
- 9) Verify that the gas inlet pressure is between the ranges shown in Table A.4 with all gas appliances (including the converted boiler) both on and off.
- 10) A sheet of yellow labels is provided in the envelope with this manual for boilers converted from natural to LP gas. Select the model from this sheet of labels and apply them as follows:
 - a. Apply the “Rating Plate Label” adjacent to the rating plate.
 - b. Apply the “Gas Valve Label” to a conspicuous area on the gas valve.
 - c. Apply the “Boiler Conversion Label” to a conspicuous surface on, or adjacent to, the outer boiler jacket. Fill in the date of the conversion and the name and address of the company making the conversion with a permanent marker.
- 11) Refer to the “Start-up and Checkout” section of the boiler installation manual and perform any checks not already completed.

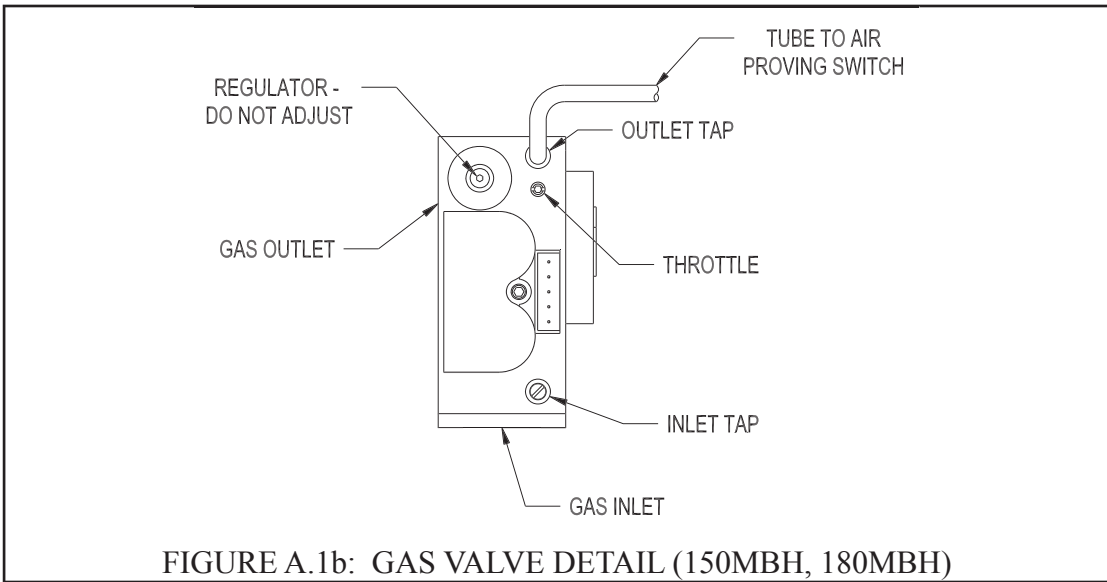
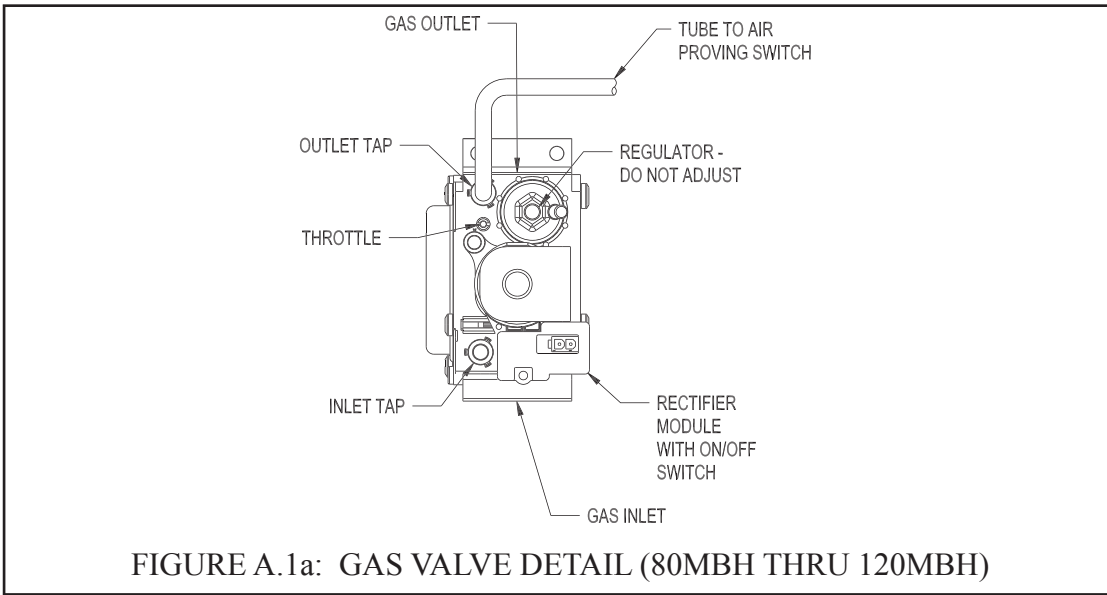

TABLE A.2: STARTING NUMBER OF THROTTLE TURNS FOR CONVERSION TO LP GAS

MODEL	# COUNTERCLOCKWISE TURNS (FROM FULLY CLOSED)
080	3-3/4
100	3
120	4
150	5-3/4
180	6-1/2

TABLE A.3: ACCEPTABLE COMBUSTION READINGS

Model	Fuel	Allowable CO2 Readings (%)				Max CO (PPM Air-Free)
		Sea Level - 2000 ft	2001 - 4500 ft	4501 - 7800 ft	7801 - 10200 ft	
80	Nat. Gas	8.7 - 9.3	NOT PERMITTED			200
	LP	10.1 - 10.3				200
100	Nat. Gas	8.5 - 9.3				200
	LP	10.1 - 10.3				200
120	Nat. Gas	8.8 - 9.3				200
	LP	10.1 - 10.3				200
150	Nat. Gas	8.6 - 9.3				200
	LP	9.7 - 10.3				200
180	Nat. Gas	8.5 - 9.1				200
	LP	9.9 - 10.3				200

TABLE A.4: ACCEPTABLE GAS INLET PRESSURE RANGE

Fuel	Inlet Pressure (in w.c.)
	Sea Level - 2000ft
Nat. Gas	2.5 - 14.0
LP	11.0 - 14

Appendix B: Special Requirements For Side-Wall Vented Appliances In The Commonwealth of Massachusetts

IMPORTANT

The Commonwealth of Massachusetts requires compliance with regulation 248 CMR 4.00 and 5.00 for installation of side-wall vented gas appliances as follows:

(a) For all side wall horizontally vented gas fueled equipment installed in every dwelling, building or structure used in whole or in part for residential purposes, including those owned or operated by the Commonwealth and where the side wall exhaust vent termination is less than seven (7) feet above finished grade in the area of the venting, including but not limited to decks and porches, the following requirements shall be satisfied:

1. **INSTALLATION OF CARBON MONOXIDE DETECTORS.** At the time of installation of the side wall horizontal vented gas fueled equipment, the installing plumber or gasfitter shall observe that a hard wired carbon monoxide detector with an alarm and battery back-up is installed on the floor level where the gas equipment is to be installed. In addition, the installing plumber or gasfitter shall observe that a battery operated or hard wired carbon monoxide detector with an alarm is installed on each additional level of the dwelling, building or structure served by the side wall horizontal vented gas fueled equipment. It shall be the responsibility of the property owner to secure the services of qualified licensed professionals for the installation of hard wired carbon monoxide detectors.

- a. In the event that the side wall horizontally vented gas fueled equipment is installed in a crawl space or an attic, the hard wired carbon monoxide detector with alarm and battery back-up may be installed on the next adjacent floor level.
- b. In the event that the requirements of this subdivision can not be met at the time of completion of installation, the owner shall have a period of thirty (30) days to comply with the above requirements; provided, however, that during said thirty (30) day period, a battery operated carbon monoxide detector with an alarm shall be installed.

2. **APPROVED CARBON MONOXIDE DETECTORS.** Each carbon monoxide detector as required in accordance with the above provisions shall comply with NFPA 720 and be ANSI/UL 2034 listed and IAS certified.

3. **SIGNAGE.** A metal or plastic identification plate shall be permanently mounted to the exterior of the building at a minimum height of eight (8) feet above grade directly in line with the exhaust vent terminal for the horizontally vented gas fueled heating appliance or equipment. The sign shall read, in print size no less than one-half (1/2) inch in size, "GAS VENT DIRECTLY BELOW. KEEP CLEAR OF ALL OBSTRUCTIONS".

4. **INSPECTION.** The state or local gas inspector of the side wall horizontally vented gas fueled equipment shall not approve the installation unless, upon inspection, the inspector observes carbon monoxide detectors and signage installed in accordance with the provisions of 248 CMR 5.08(2)(a)1 through 4.

(b) **EXEMPTIONS:** The following equipment is exempt from 248 CMR 5.08(2)(a)1 through 4:

1. The equipment listed in Chapter 10 entitled "Equipment Not Required To Be Vented" in the most current edition of NFPA 54 as adopted by the Board; and
2. Product Approved side wall horizontally vented gas fueled equipment installed in a room or structure separate from the dwelling, building or structure used in whole or in part for residential purposes.

(c) **MANUFACTURER REQUIREMENTS - GAS EQUIPMENT VENTING SYSTEM PROVIDED.** When the manufacturer of Product Approved side wall horizontally vented gas equipment provides a venting system design or venting system components with the equipment, the instructions provided by the manufacturer for installation of the equipment and the venting system shall include:

1. Detailed instructions for the installation of the venting system design or the venting system components; and
2. A complete parts list for the venting system design or venting system.

(d) MANUFACTURER REQUIREMENTS - GAS EQUIPMENT VENTING SYSTEM NOT PROVIDED. When the manufacturer of a Product Approved side wall horizontally vented gas fueled equipment does not provide the parts for venting the flue gases, but identifies “special venting systems”, the following requirements shall be satisfied by the manufacturer:

1. The referenced “special venting system” instructions shall be included with the appliance or equipment installation instructions; and
2. The “special venting systems” shall be Product Approved by the Board, and the instructions for that system shall include a parts list and detailed installation instructions.

(e) A copy of all installation instructions for all Product Approved side wall horizontally vented gas fueled equipment, all venting instructions, all parts lists for venting instructions, and/or all venting design instructions shall remain with the appliance or equipment at the completion of the installation.

Appendix C: Control Set-up Using PIM

This boiler's control is equipped with a Program Module (PIM). This device is essentially a special "memory stick" containing a copy of the software parameters that were programmed into the control by the factory. This PIM has two uses:

- 1) If the control must be replaced, the data on this PIM may be transferred to a "universal" replacement control, so that it is correctly programmed with the parameters unique to the boiler at the installation.
- 2) The PIM provides the service technician with an easy way to return all control adjustments to their original factory settings.



WARNING

Asphyxiation Hazard. Do not attempt to use this PIM on boiler models for which it is not intended. All PIMs show the size of the Shadow boiler for which they are intended on the front label. If this label is missing or unreadable, do not use the PIM. Unauthorized use of PIMs may cause property damage, personal injury or loss of life.

A. Removal and insertion of PIM

To remove the PIM gently press the tabs at the top and bottom of the PIM and pull straight back (Figure C.1). Replacement controls are not equipped with a PIM and a dust cover is supplied in the PIM slot, which is removed in the same way. If the control is being replaced, insert the PIM from the old control into the slot on the new control. The PIM may be inserted or removed while the control is powered.

B. Uploading PIM Data

To upload PIM data use the following procedure:

- 1) Verify that the PIM is the correct one for this boiler. If the control is being replaced, also verify that the replacement control is intended for use on this boiler.
- 2) If not already done, power up the boiler with the new control in place and wait for the appearance of the home screen (Figure C.2)
- 3) Press and hold the RH and DWN button for approximately 3 seconds until "RES" screen shown in Figure C.3 appears).
- 4) Press the RH button to confirm that you want to upload the PIM data onto the control. Note: if you reach this screen by mistake, you can escape without uploading the PIM by cycling power to the boiler.
- 5) "RES" will flash during the uploading process. If the uploading process is successful "RES" will stop flashing after a few seconds. Pressing LH ("Done") at this point, will return to the Home Screen.
- 6) If there is a problem, an Error code will appear on the screen. The meaning of these codes is shown in Table C.4. Pressing the LH (Done) button will return the user to the home screen without any uploading having been done. Pressing "Next" will return the user to the RES screen for another attempt.

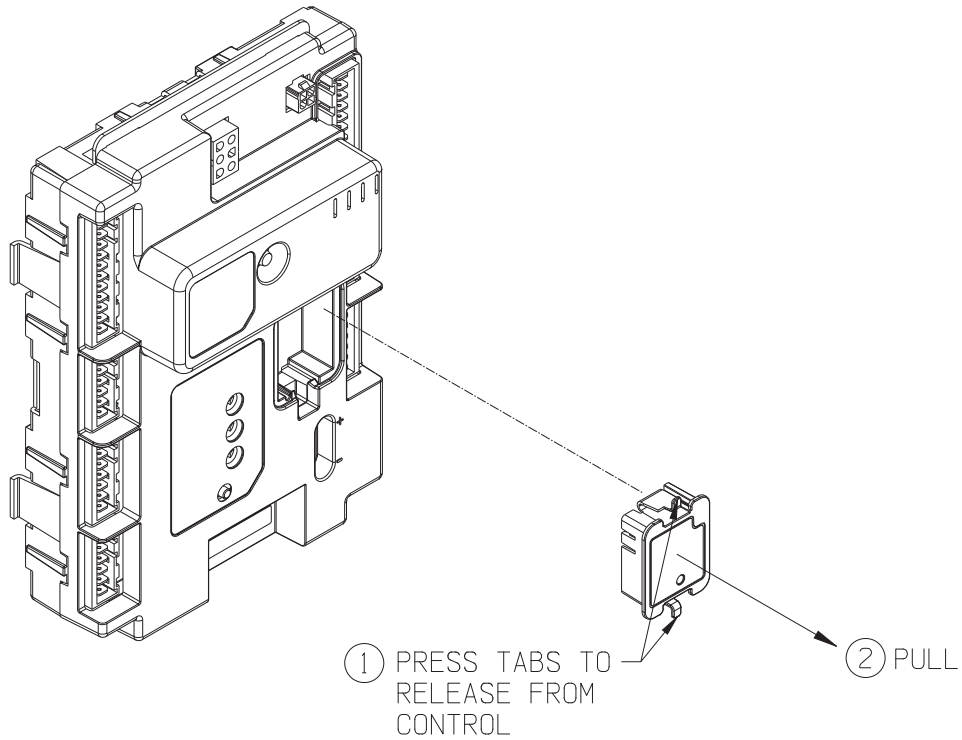

FIGURE C1: REMOVAL OF PIM

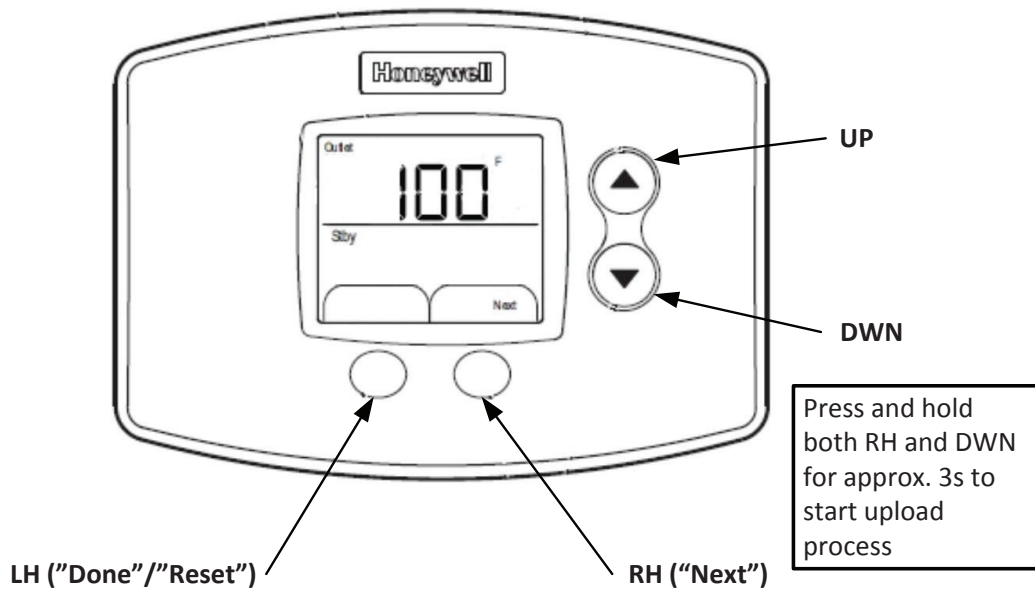

FIGURE C2: HOME SCREEN

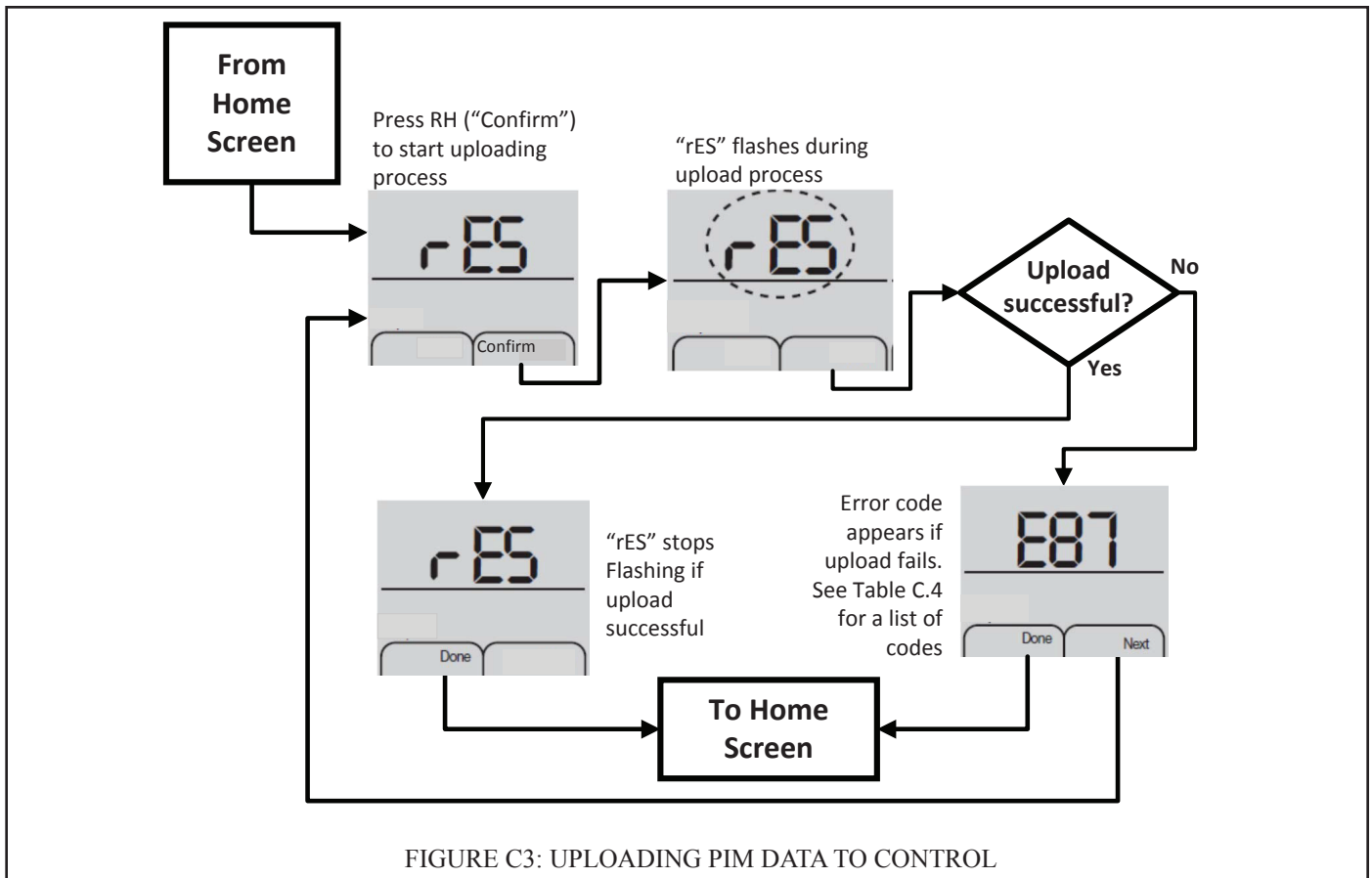

FIGURE C3: UPLOADING PIM DATA TO CONTROL

FIGURE C.4: PIM ERROR CODES

Code	Meaning	Possible Causes/Remedies
E81	Password not recognized.	Correct display does not require a password, so this is a possible indication of incompatible display or control. If either has been replaced, verify that it is the correct type specified by the parts list in manual. Try upload again. If problem persists, consult factory.
E82	PIM not detected in socket	Improperly seated or missing PIM.
E85	PIM is not compatible with the control	Either PIM or replacement control is not intended for use on this boiler. Check part numbers on both with replacement parts list in manual.
E88	Command from display not recognized	Try upload again, if problem persists, replace display.
E98	Timeout	Possible indication of incompatible display. If display has been replaced, verify that it is the correct type specified by the parts list in manual. If problem persists, replace PIM.
E83, E84, E87, E89	Various	These errors should never occur on this boiler. If one appears, verify compatibility of control, PIM, and display (all should match what is shown in the parts list in manual). Try upload again. If problem persists, consult factory.

Velocity Boiler Works, LLC
P.O. Box 14818
3633 I Street
Philadelphia, PA 19134
www.velocityboilerworks.com