

3 - 5 TON PACKAGED GAS/ELECTRIC UNITS  
14 SEER / UP TO 12.0 EER

## SUBMITTAL DATA FORM

Job Name \_\_\_\_\_

Location \_\_\_\_\_

Purchaser \_\_\_\_\_

Order No. \_\_\_\_\_

Engineer \_\_\_\_\_

Unit No. \_\_\_\_\_

Model No. \_\_\_\_\_

Unit Designation \_\_\_\_\_

Performance Data Certified By:

\_\_\_\_\_

### Standard Features

- Patented tubular heat exchanger
- High-efficiency scroll compressor
- High and low-pressure switches
- Copper tube / aluminum fin coils
- Contactor with lugs
- High-capacity, steel-cased filter drier
- 24-volt terminal strip
- Convertible airflow orientation
- Easy to service
- Built-in filter rack with standard 2" filters
- Bottom utility entry
- Complies with California Low NOx emissions standards
- 3-5 Tons with single speed blower motor units meet the performance specified in Table 6.8.1-1 of ASHRAE Standard 90.1-2013
- AHRI Certified; ETL Listed

### Cabinet Features

- Heavy-gauge, galvanized-steel cabinet with UV-resistant powder-paint finish
- Full Perimeter Rail
- Sloped drain pan



\* Complete warranty details available from your local distributor or manufacturer's representative or at [www.daikincomfort.com](http://www.daikincomfort.com).

**PERFORMANCE DATA**

<b>Cooling Performance</b>		
Total Capacity	_____	MBH
Sensible Capacity	_____	MBH
Outdoor Design TMP	_____	°F DB / WB
Air Temp entering	_____	
Evaporator Coil	_____	°F
Power Input Required (less blower motor)	_____	kW
<b>Heating Performance</b>		
Total Heating Capacity	_____	kW
	_____	BTU/h
<b>Supply Air Blower Performance</b>		
Total Supply Air	_____	CFM
Ext. Static Pressure	_____	IWG
Blower Speed	_____	RPM
Power Output Required	_____	BHP
Motor Ratings	_____	HP
Power Input Required	_____	kW
<b>Electrical Data</b>		
Power Supply	_____	
Total Unit Amps	_____	Amps
<b>Max Overcurrent Device:</b>		
Fuse	_____	Breaker _____
		Amps _____

**DIMENSIONS**

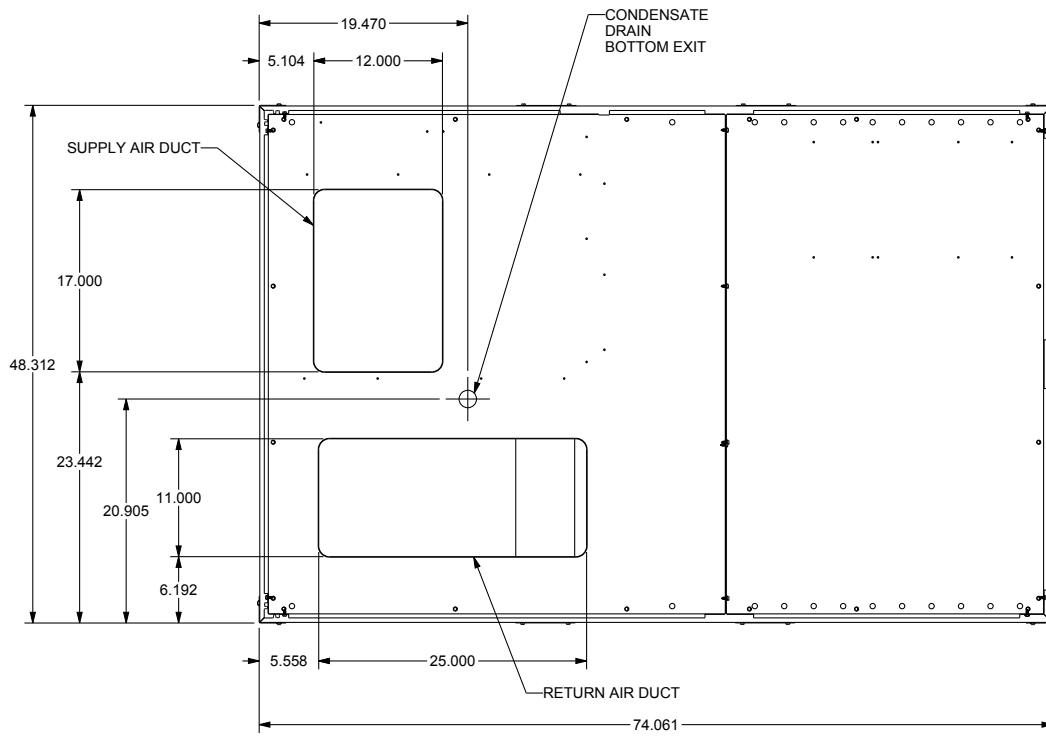

BASE PAN VIEW  
(VIEWED FROM TOP)

MODEL TONNAGES	"A"	"B"	"C"
3 TON COMMERCIAL GAS, HT PUMP, AIR CONDITIONER	38.840	16.555	26.055
4 TON COMMERCIAL GAS, HT PUMP, AIR CONDITIONER	38.840	16.555	26.055
5 TON COMMERCIAL GAS, AIR CONDITIONER	38.840	16.555	26.055
5 TON COMMERCIAL HT PUMP	42.840	20.555	30.055

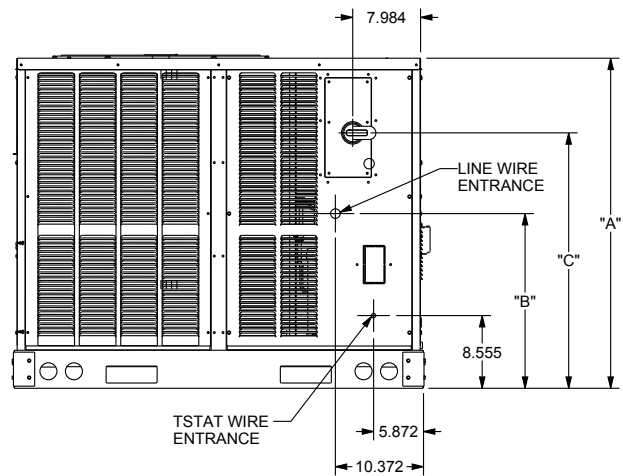

LEFT END VIEW

**ACCESSORIES**

DAIKIN MASTER ITEM #	DESCRIPTION	FITS MODEL SIZES	FIELD- INSTALLED	FACTORY- INSTALLED	✓
	<b>Curb</b>				
14CURB3672B	14" Roof Curb	3-5 Tons	✓		
18CURB3672B	18" Roof Curb	3-5 Tons	✓		
24CURB3672B	24" Roof Curb	3-5 Tons	✓		
GHRC-3672	Hurricane Restraint Clips	3-5 Tons	✓		
	<b>Ultra Low-Leak Economizer &amp; Power Exhaust<sup>1</sup></b>				
10-365-09C	Ultra Low-Leak Downflow Economizer w/ Dry Bulb	3-5 Tons	✓		
10-366-09C	Ultra Low-Leak Downflow Economizer w/ Enthalpy	3-5 Tons	✓	✓	
10-395-09	Ultra Low-Leak Horizontal Economizer w/ Dry Bulb	3-5 Tons	✓		
10-396-09	Ultra Low-Leak Horizontal Economizer w/ Enthalpy	3-5 Tons	✓		
10-455-09*-23	Centrifugal Power Exhaust 230v	3-5 Tons	✓		
10-455-09*-33	Centrifugal Power Exhaust 460v	3-5 Tons	✓		
10-455-09*-43	Centrifugal Power Exhaust 575v	3-5 Tons	✓		
10-457-09xA-23	Modulating Power Exhaust 208-230v	3-5 Tons	✓		
10-457-09xA-33	Modulating Power Exhaust 460v	3-5 Tons	✓		
10-465-09-21	Prop Power Exhaust 230v	3-5 Tons	✓		
10-465-09-31	Prop Power Exhaust 460v	3-5 Tons	✓		
10-465-09-41	Prop Power Exhaust 575v	3-5 Tons	✓		
	<b>Low-Leak Economizer &amp; Power Exhaust<sup>2</sup></b>				
DDNECNJ3672C	Low-Leak Downflow Economizer	3-5 Tons	✓	✓	
DPE36722	Downflow Power Exhaust (208/230 Volt)	3-5 Tons	✓		
DPE36724	Downflow Power Exhaust (460 Volt)	3-5 Tons	✓		
DPE36727	Downflow Power Exhaust (575v)	3-5 Tons	✓		
DHZECNJ3672	Horizontal Economizer	3-5 Tons	✓		
DHPE36722	Horizontal Power Exhaust (208/230 Volt)	3-5 Tons	✓		
DHPE36724	Horizontal Power Exhaust (460 Volt)	3-5 Tons	✓		
DHPE36727	Horizontal Power Exhaust (575 Volt)	3-5 Tons	✓		
	<b>Downflow Accessories</b>				
D25FD3672	25% Manual Fresh Air Damper	3-5 Tons	✓		
D25MFD3672	25% Motorized Fresh Air Damper	3-5 Tons	✓		
DDNBBS3672	Burglar Bar Sleeves with Supply & Return	3-5 Tons	✓		
DDNECNJ3672NR	Downflow Economizer2 w/o Barometric Relief	3-5 Tons	✓		
DDNSQRD3616	Downflow Square-to-Round Adapter (16" Round)	3 tons	✓		
DDNSQRD487218	Downflow Square-to-Round Adapter (18" Round)	4-5 tons	✓		
	<b>Horizontal Accessories</b>				
DBRD3672	Barometric Relief Damper	3-5 Tons	✓		
	<b>Concentrics</b>				
CDK36	Concentric Duct Kit	3 Ton	✓		
CDK36515	Flush Mount Concentric Duct Kit w/ Filter	3 Ton	✓		
CDK36530	Step Down Concentric Duct Kit	3 Ton	✓		
CDK36535	Step Down Concentric Duct Kit w/ Filter	3 Ton	✓		
CDK4872	Concentric Duct Kit	4-5 Ton	✓		

## ACCESSORIES (CONT.)

DAIKIN MASTER ITEM #	DESCRIPTION	FITS MODEL SIZES	FIELD- INSTALLED	FACTORY- INSTALLED	✓
CDK4872515	Flush Mount Concentric Duct Kit w/ Filter	4-5 Ton	√		
CDK4872530	Step Down Concentric Duct Kit	4-5 Ton	√		
CDK4872535	Step Down Concentric Duct Kit w/ Filter	4-5 Ton	√		
	<b>DDC Accessories<sup>3</sup></b>				
	DDC communicating controller (built-in BACnet® MS/TP) includes Standard Room Sensor to be installed in field	3-5 Tons		√	
10366D09C	DDC Ultra Low-Leak Downflow Economizer	3-5 Tons	√	√	
10366D09	DDC Ultra Low-Leak Horizontal Economizer	3-5 Tons	√		
10465DDC	Power Exhaust kit used with DDC Ultra Low-Leak Economizer	3-5 tons	√		
DLAKT01	Low-Ambient	3-5 Tons	√	√	
LONKT01	LonWorks® card	3-5 Tons	√		
3PMK01	Phase Monitor (3-Phase Only)	3-5 Tons	√	√	
DFSKT01	Dirty Filter Switch	3-5 Tons	√		
	<b>High-Static Kits<sup>4</sup></b>				
HSKTS036	High Static Kit - 230v & 460v	DS*, 3 Ton	√	√	
HSKTS048	High Static Kit - 230v & 460v	DS*, 4 Ton	√	√	
HSKTS060	High Static Kit - 230v & 460v	DS*, 5 Ton	√	√	
HSKTS036-7	High Static Kit - 575v	DS*, 3 Ton	√	√	
HSKTS048-7	High Static Kit - 575v	DS*, 4 Ton	√	√	
HSKTS060-7	High Static Kit - 575v	DS*, 5 Ton	√	√	
	<b>Crankcase Heater Kits</b>				
0163R00002S	40W 230V	3 tons	√		
0163R00031S	40W 460V	3 tons	√		
0163R00032S	40W 575V	3 tons	√		
0130L00017S	70W 230V	4 - 5 tons	√		
0130L00018S	70W 460V	4 - 5 tons	√		
0130L00019S	70W 575V	4 - 5 tons	√		
	<b>High Efficiency Filters</b>				
0160L00203	High Efficiency MERV 13 Air Filter Nom. Size: 24x24x2; (Order Qty 1)	3 tons	√		
0160L00204	High Efficiency MERV 13 Air Filter Nom. Size: 14x20x2; (Order Qty 4)	4 tons	√		
0160L00205	High Efficiency MERV 13 Air Filter Nom. Size: 16x20x2; (Order Qty 4)	5 tons	√		
	<b>Misc Accessories</b>				
HAILGD03D	Condenser Coil Hail Guard	3-5 tons	√		
	Convenience Outlet: Non Powered	3-5 tons		√	
	Convenience Outlet: Powered	3-5 tons		√	
	Disconnect Switch	3-5 tons		√	
LAKT11	Low Ambient Kit, 208-230V - non-DDC	3-5 tons	√	√	
LAKT13	Low Ambient Kit, 460V - non-DDC	3-5 tons	√	√	
LAKT14	Low Ambient Kit, 575V - non-DDC	3-5 tons	√	√	

DAIKIN MASTER ITEM #	DESCRIPTION	FITS MODEL SIZES	FIELD- INSTALLED	FACTORY- INSTALLED	✓
3PMNDK01	Phase Monitor - Non DDC	3-5 Ton	√	√	
	Smoke Detector (supply and/or return air)	3-5 Ton		√	
	Hinged Panels	3-5 Ton		√	
FSK01A	Freeze Stat Kit	3-5 Ton	√		
IRKT-01	Isolation Relay Kit	3-5 Ton	√		
LPM-07	LP Conversion Kit (For DSG036045 unit only)	3 Ton	√		
LPM-08	LP Conversion Kit	3-5 Ton	√		
220-GX-01	Flue Extension Kit	3-5 Ton	√		
HA036300	High Altitude Kit	3-5 Ton	√		

<sup>1</sup> Use Economizer & Power Exhaust listed within Ultra Low-Leak section

<sup>2</sup> Use Economizer & Power Exhaust listed within Low-Leak section

<sup>3</sup> For a full list of DDC accessories, please refer to DDC Controller Technical Guide manual (DK-DDC-TGD-01B)

<sup>4</sup> HSKT High-Static Kits are for use with standard single-speed belt-drive units only.

**Note:** Where multiple variations are available, the heaviest combination is listed.

### ROOF CURB — #D14CURB3672

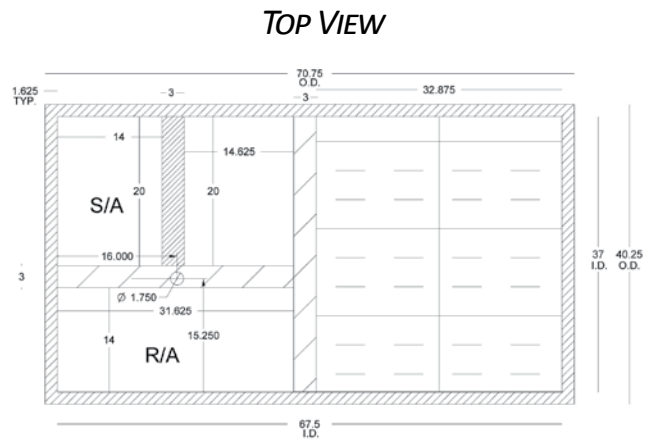
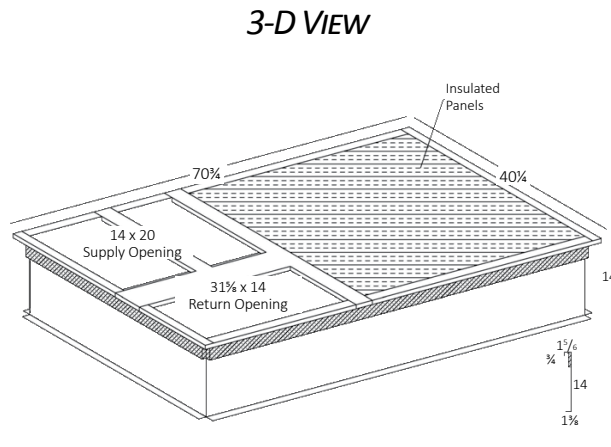

### SPECIFICATIONS

- 18-Gauge Construction
- 1 x 4 Wood Nailer attached to top of the curb
- Shipped knocked down with all hardware
- Gasket included
- Bed-Rail style corners

Note: outside duct dimension should be 1/2" less than opening dimensions above.

### NO CURB ADAPTER REQUIRED WHEN REPLACING CARRIER & BRYANT MODELS

No curb adapter is required when replacing an existing Carrier or Bryant RTU with a Daikin RTU in these situations; the footprints and locations of the return and supply duct work match.

NEW UNIT	EXISTING CARRIER	EXISTING BRYANT
3 TO 5 TONS	48/50 TJ, LJ, DJ, QJ 48/50 TM, HJ 004 - 007	580C-D, 558C-D, 548C-D 580F, 558F, 581B 036 - 072

**MANUAL FRESH AIR DAMPER — #D25FD3672****MOTORIZED FRESH AIR DAMPER — #D25MFD3672****SPECIFICATIONS****Manual Damper**

- Provides up to 25% fresh air
- Locking selection knob provides constant opening
- Painted to match the unit
- Fits all 3- to 5-ton package units in all fuels

**Motorized Damper**

- 24 VAC Damper motor with spring return
- Fully assembled and factory wired
- Painted to match the unit
- Fits all 3- to 5-ton package units in all fuels

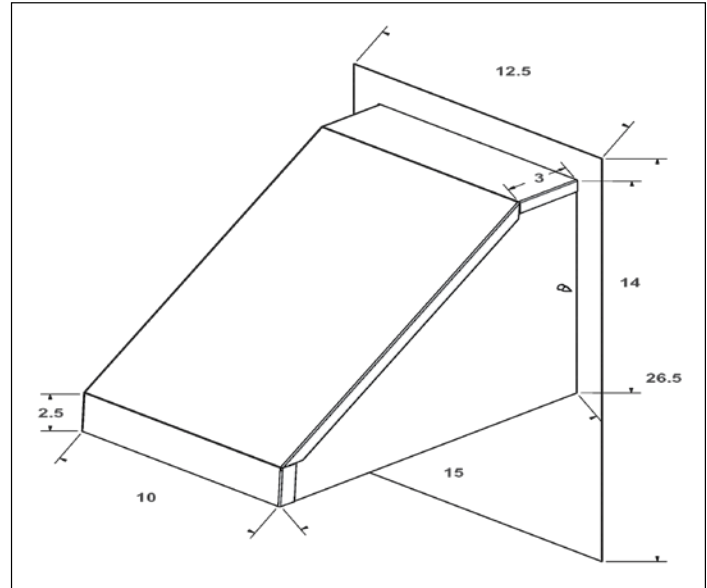
**HAIL GUARD — #HAILGDO\*****SPECIFICATIONS**

- Condenser coil protection
- Prevents hail damage
- Easy to remove and clean
- Powder paint finish

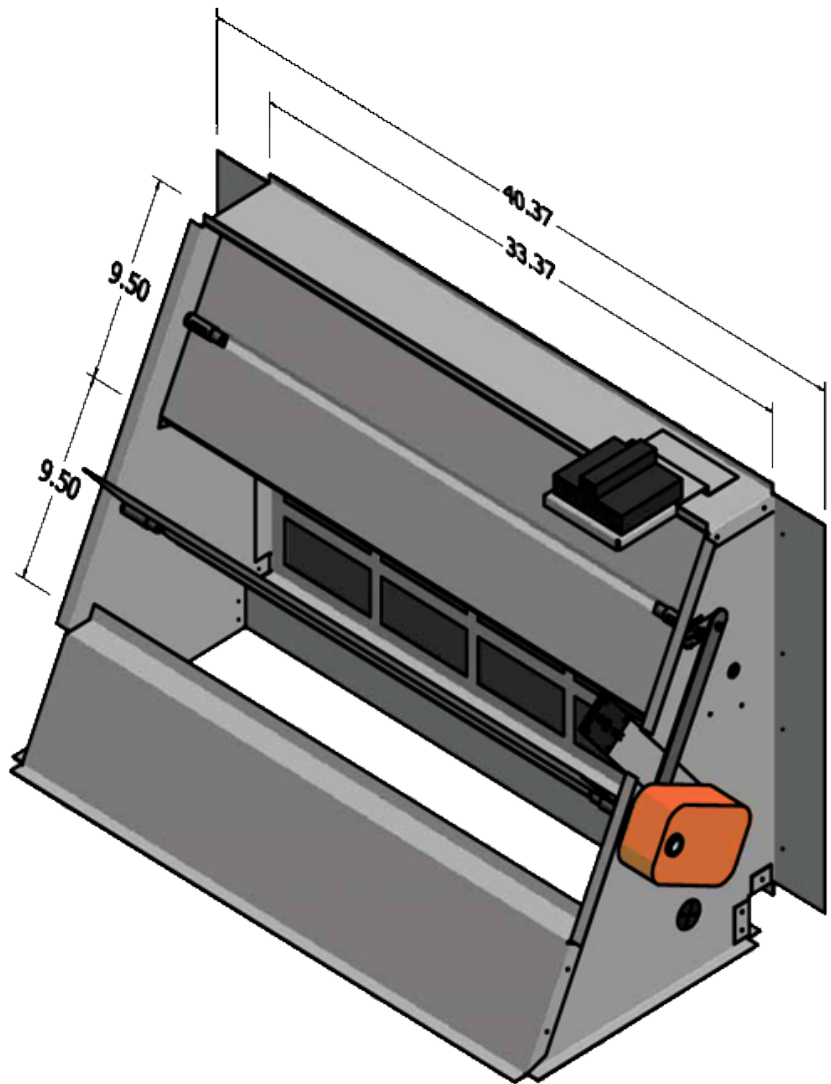

**DOWNFLOW ECONOMIZER — #DDNECNJ3672****SPECIFICATIONS**

- Fully modulating
- Up to 100% fresh air
- Integral barometric relief
- Hoods painted to match unit
- Honeywell economizer control
- Single adjustable enthalpy control convertible to dual enthalpy
- Adjustable minimum fresh air
- Factory wired
- Fits all 3 - 5 ton models

**HORIZONTAL ECONOMIZER — #DHZECNJ3672**

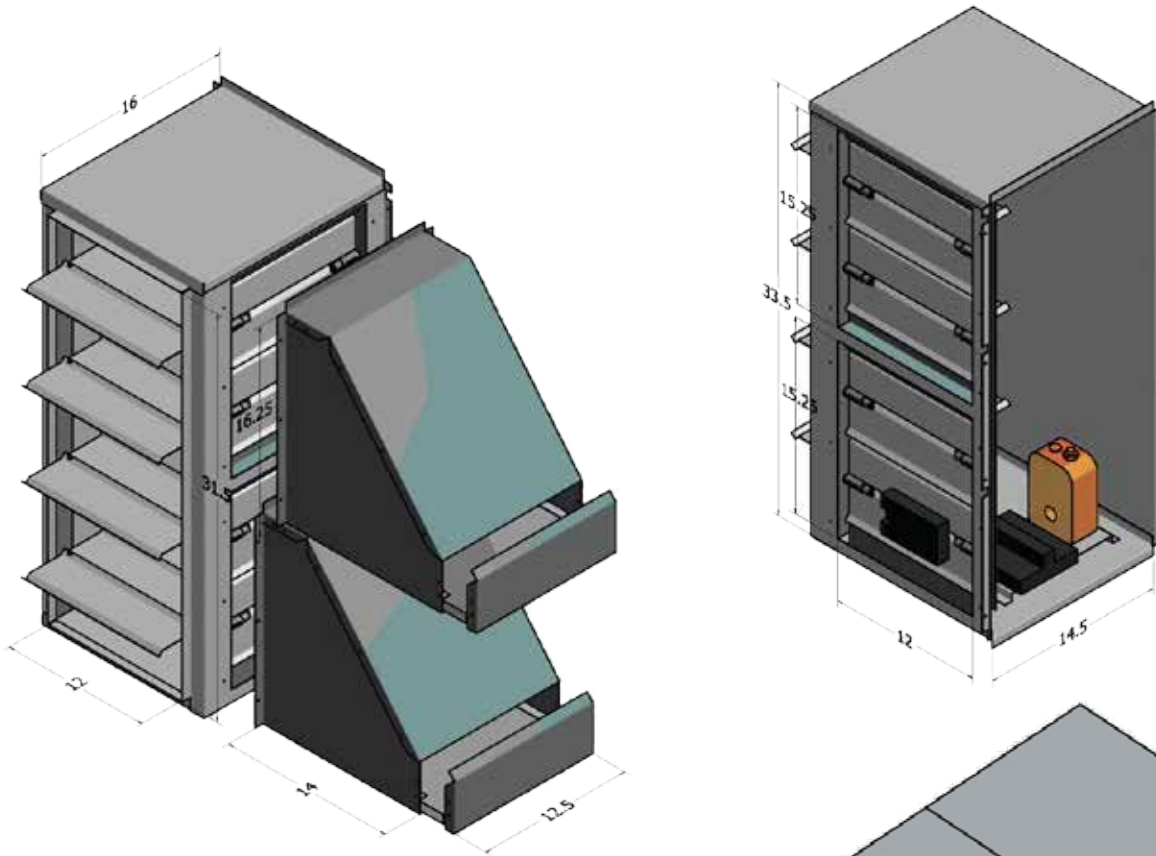

**SPECIFICATIONS**

- Fully modulating
- Up to 100% fresh air
- Honeywell economizer control
- Single adjustable enthalpy control convertible to dual enthalpy
- Adjustable minimum fresh air
- Factory wired
- Fits all 3 - 5 ton models

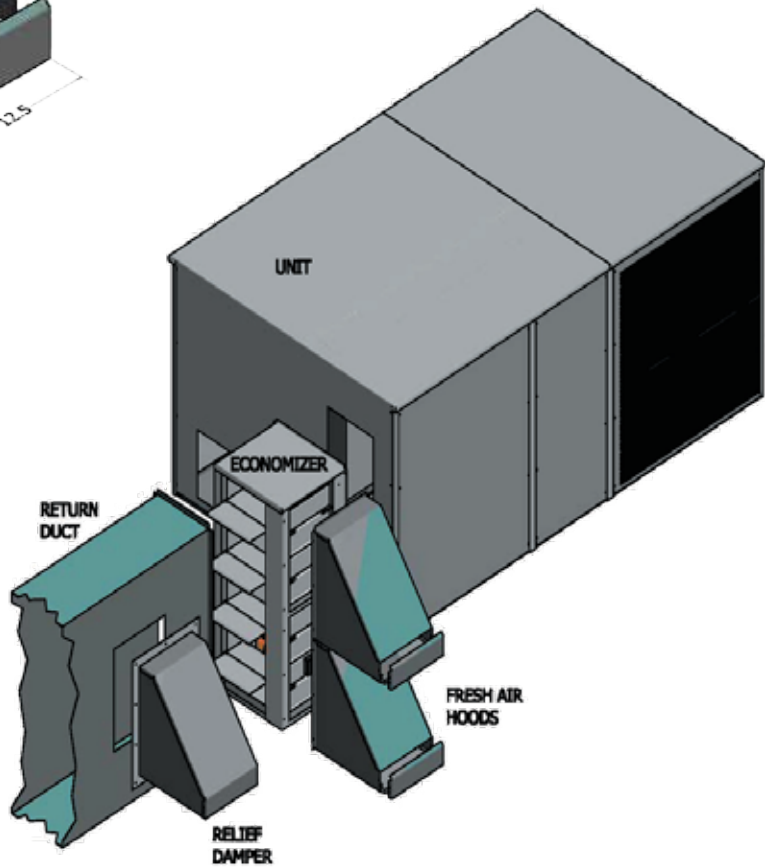

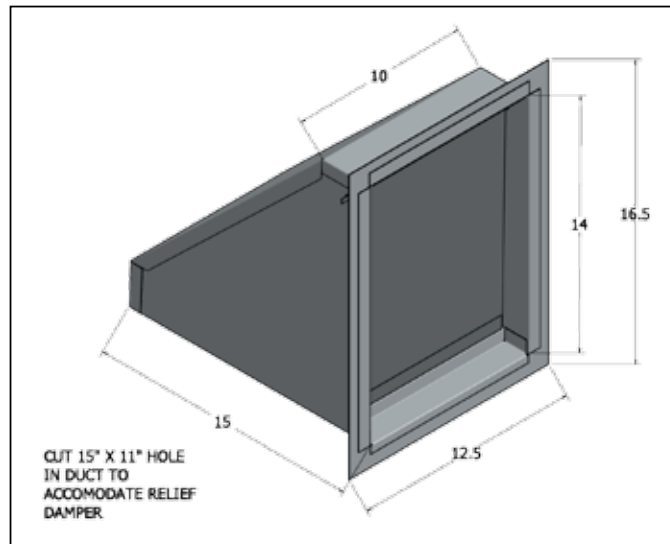
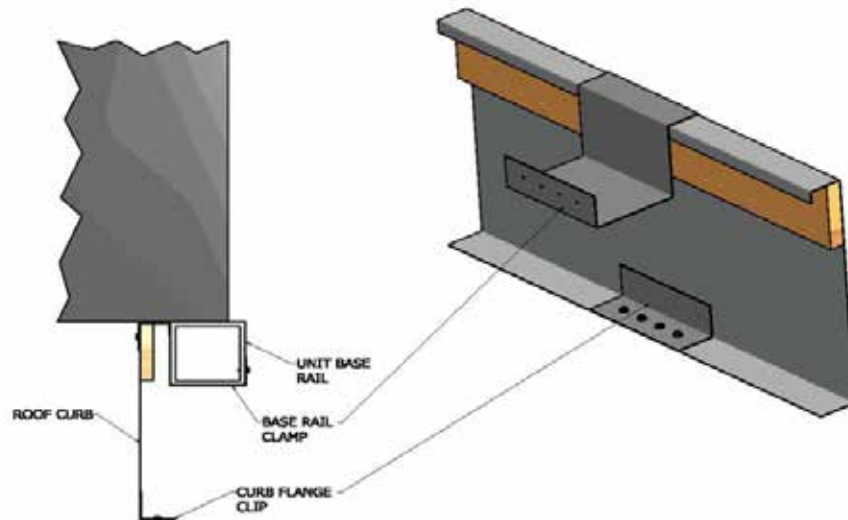
**BAROMETRIC RELIEF DAMPER — #DBRD3672****HURRICANE / SEISMIC CLIP — GHRC-3672B****SPECIFICATIONS**

- 14-gauge construction
- Location and quantity of clips dictated by unit need
- Clips are fastened to the unit and curb using sheet-metal screws
- Seismic angle is fastened with approved fastener

### CONCENTRIC DUCT KIT — #CDK36 / #CDK4872

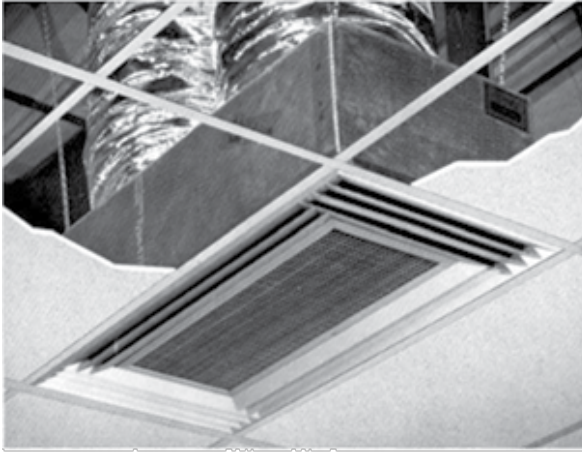

Light Commercial  
T-Bar Ceiling

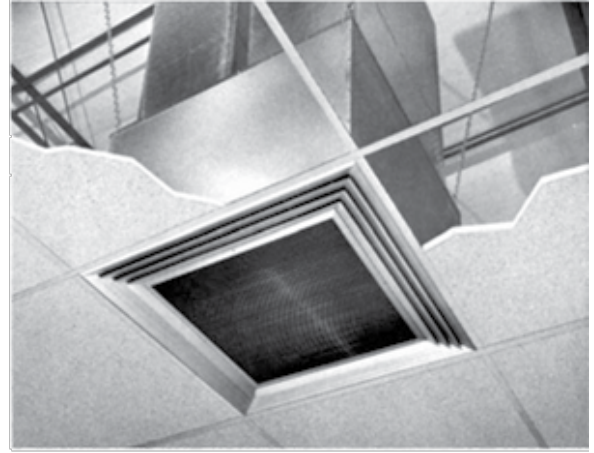

Commercial  
T-Bar Ceiling

#### SPECIFICATIONS

- All-aluminum diffuser with aluminum return air egg crate
- Built-in anti-sweat gasket
- Molded fiberglass transition (through five tons)
- Built-in hanging supports
- Diffuser box constructed of fiberglass duct board (through 7½ tons) or sheet metal

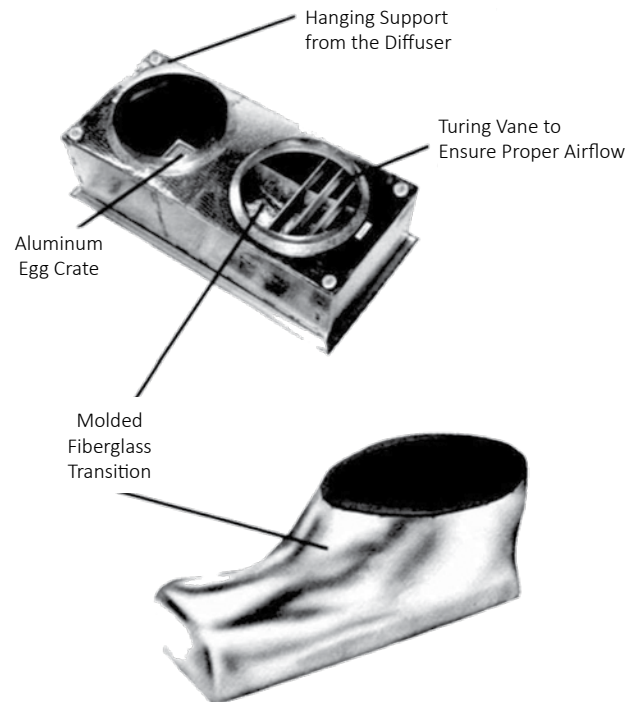

3 - TON SQUARE-TO-ROUND — #DDNSQRD3616

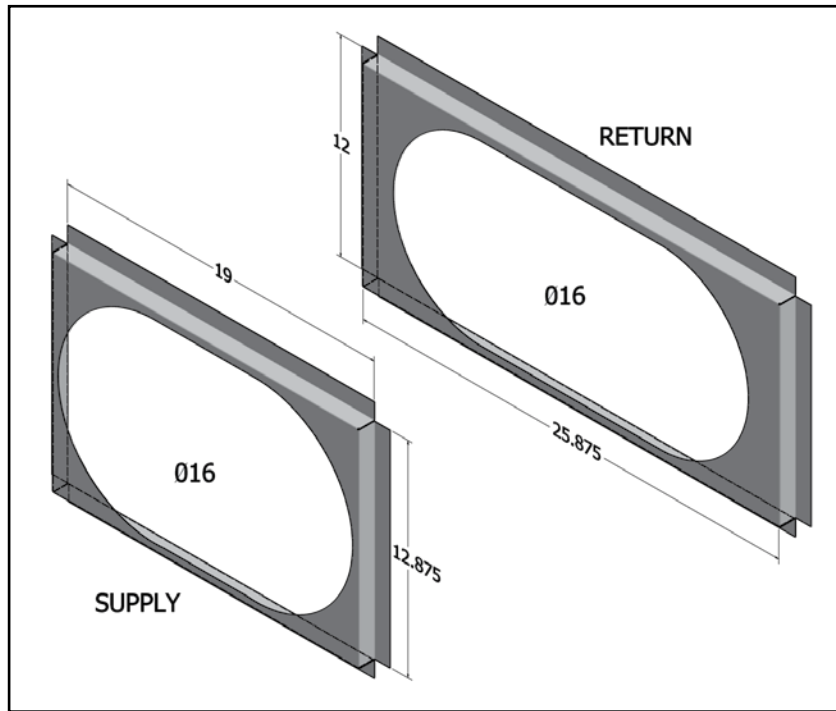

4 - 5 TON SQUARE-TO-ROUND — #DDNSQRD487218

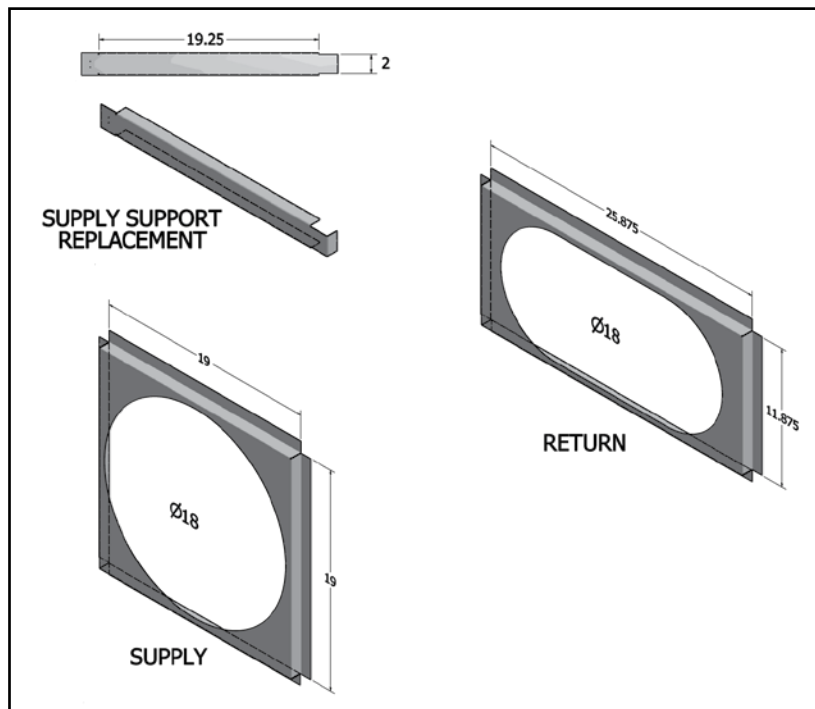

*NOTES*

*NOTES*

*NOTES*