



GAS-FIRED HIGH AND LOW INTENSITY INFRARED HEATERS



MODEL IHR



MODEL OHP



MODEL IPT

This catalog describes the design and construction features and benefits, typical applications, dimensional data, and configurations available for the IHR and ITP Series.

Modine's IHR Series is a gas-fired, high intensity ceramic infrared heater. Ideal for spot heating, the IHR series offers simple gas and power connections, as well as inexpensive maintenance.

Modine's IPT Series sets the industry standard for low intensity infrared heating performance and installation versatility. The comfort and uniform heating provided by the IPT Series are second to none.

Table of Contents

General Unit Applications..... 2
 Infrared Heating Defined..... 2
 Advantages of Infrared Heating 2
 Typical Applications..... 2
 Modine Breeze® AccuSpec Sizing and Selection Program 3
 Features and Benefits - Model IHR..... 4
 Features and Benefits - Model IHR..... 5
 Features and Benefits - Model IPT 6
 Performance and Dimensional Data - Model IHR 7-8
 Performance and Dimensional Data - Model OHP 9
 Performance, Utilities, and Clearance - Model IPT 10
 Dimensional Data - Model IPT 11
 Specifications and Model Nomenclature - Model IHR 12
 Specifications and Model Nomenclature - Model IPT 13

Infrared Heating Defined

Infrared heating systems rely upon the transfer of radiant energy from hot heat exchanger surfaces (up to 1850°F for high intensity heaters) through the air to cooler surfaces, without the use of an air mover. Since radiant energy always travels in a straight line from its source, people and objects within a direct line-of-sight of the heat exchanger become warmed immediately.

While capable of being used for total building heating or large area heating, they are ideally suited for spot heating applications. Spot heating involves small areas such as loading dock doors and single person work cells.

Advantages of Infrared Heating

- No air mover, reducing electricity and maintenance costs while increasing worker comfort from the absence of drafts and annoying fan noise.
- Quick temperature recovery, as only objects need to be heated, not large volumes of air.
- Significant energy savings through use of zone control and/or spot heating, which heats objects without the need to heat large air volumes.

Typical Applications

The following are examples of applications that can benefit from high-intensity infrared heating:

- Manufacturing facilities
- Vehicle repair centers
- Warehouses and loading docks
- Aircraft hangars
- Indoor tennis courts
- Indoor golf driving ranges
- Emergency vehicle garages
- Indoor stadium seating areas

The following are examples of applications that can benefit from low-intensity infrared heating:

- Manufacturing facilities
- Vehicle repair centers
- Warehouses and loading docks
- Aircraft hangars
- Tennis courts
- Car washes
- Golf driving ranges
- Covered walkways
- Emergency vehicle garages
- Stadium seating areas
- Vestibules

See Infrared Design and Engineering Guide 9-200 for additional application information.



Refer to page 3 for information regarding the Breeze® AccuSpec Sizing and Selection Program



! WARNING
 Do not locate ANY gas-fired unit in areas where chlorinated, halogenated or acid vapors are present in the atmosphere.

! WARNING
 Do not install in potentially explosive or flammable atmosphere laden with dust, sawdust, or similar airborne materials.

As Modine Manufacturing Company has a continuous product improvement program, it reserves the right to change design and specifications without notice.



Modine Breeze® AccuSpec Sizing and Selection Program

The Modine Breeze® AccuSpec is the fastest way to generate performance data based on actual job conditions. The Breeze® AccuSpec program is a web-based sizing and selection program. The program provides a series of step-by-step questions that allow for the easy configuration of Modine products. After a model has been configured, the program can generate Submittal Schedules, Submittal Data (including performance and dimensional drawings), and Specifications.

Fast and Simple Unit/Thermostat/Accessory Selection

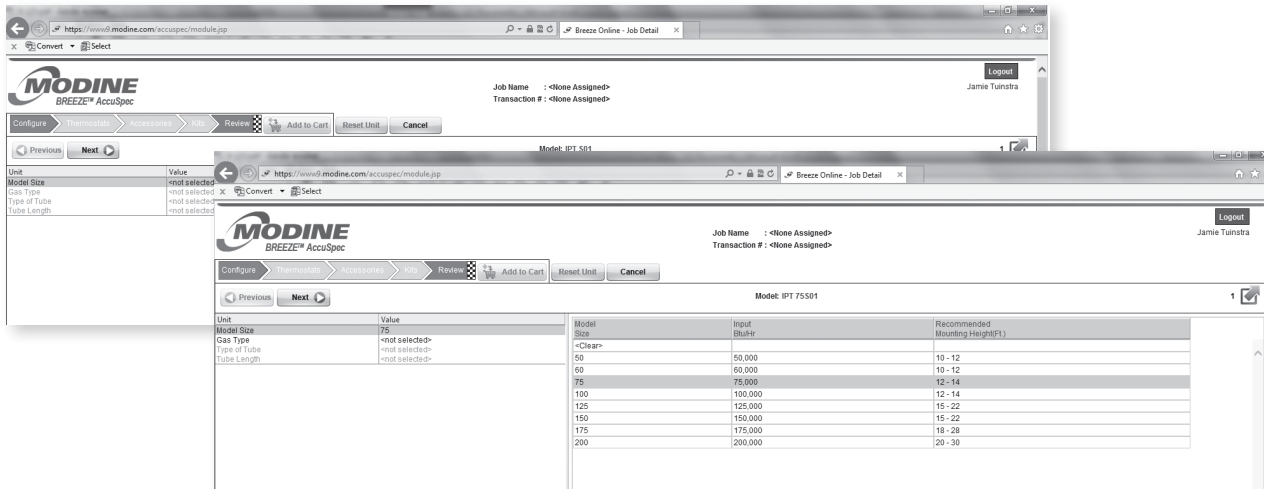

Submittal Schedules

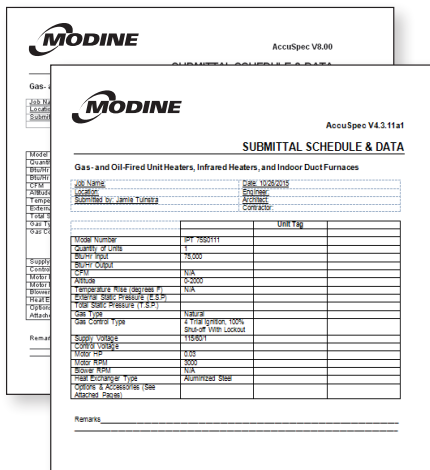

Unit Specific Dimensional Drawings

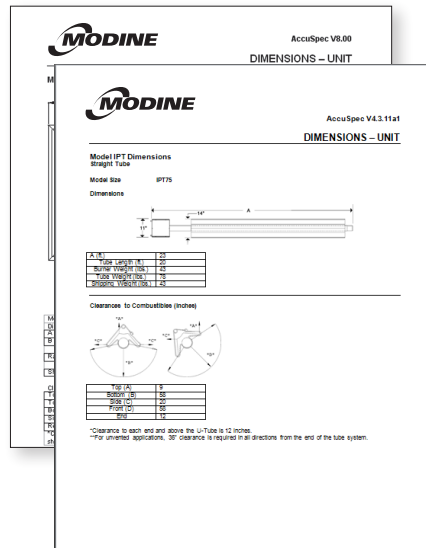

Job Specific Specifications

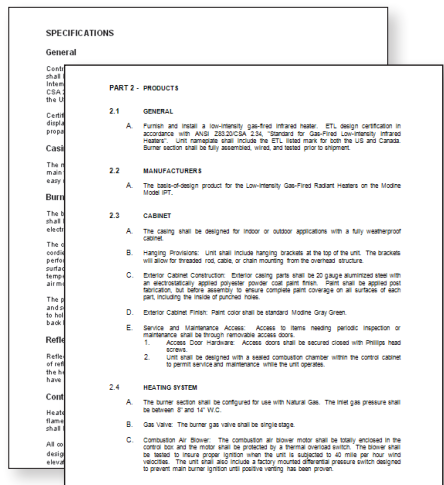

For access to the Breeze® AccuSpec program, contact your local Modine sales representative.

Figure 4.1 - Construction Features - Model IHR



Features	Benefits
1. High temperature cordierite-based grooved ceramic tiles with perforations along both the top and bottom of the grooves	1. Increased temperature and surface area to provide maximum heat transfer while maintaining lower gas input ratings.
2. Polished aluminum reflectors	2. Efficiently direct radiant heat to the desired area, for increased comfort over wider areas.
3. 16 gauge aluminized steel frame	3. Provides support for simple chain mounting.
4. No air mover is utilized	4. Eliminates fan noise, drafts, maintenance and reduces electrical energy costs.
5. Input ranges from 30,000 Btu/hr through 160,000 Btu/hr in Natural or Propane gas	5. Wide input range to accommodate a variety of heating requirements
6. Direct spark or self-energizing standing pilot ignition	6. Maximize application flexibility.
7. 115V, 25V, or millivolt controls	7. Accommodate a wide range of electrical inputs.
8. Externally-mounted controls	8. Allow convenient access to gas valve, control system, transformer, and gas orifices, increasing ease of installation and service.
9. Burners are replaced by removing one fastener	9. Eliminates the removal of the unit from its mounted position for service.
10. CSA design certification for indoor, unvented operation in commercial and industrial installations	10. Assures that the unit conforms to national safety standards.

Figure 5.1 - Construction Features - Model OHP



Features	Benefits
1. ETL Design Certified to ANSI Z83.26 Standard	1. Assures that the unit conforms to national safety standards.
2. Decorative stainless steel windscreen eggcrate grille	2. Prevents wind disturbance.
3. Wind and rain protected design	3. Input range to accommodate a variety of heating requirements.
4. 31,000 and 34,000 BTU inputs. Natural or propane gas	4. Flexible fuel type offering.
5. No Fan Design.	5. Eliminates fan noise, drafts, maintenance and reduces electrical energy costs.
6. Externally-mounted controls	6. Allow convenient access to gas valve, control system, transformer, and gas orifices, increasing ease of installation and service.
7. Direct spark or self-energizing standing pilot ignition	7. Maximize application flexibility.
8. Brushed 430 Stainless Steel Housing	8. Provides maximum corrosion resistance.

Figure 6.1 - Construction Features

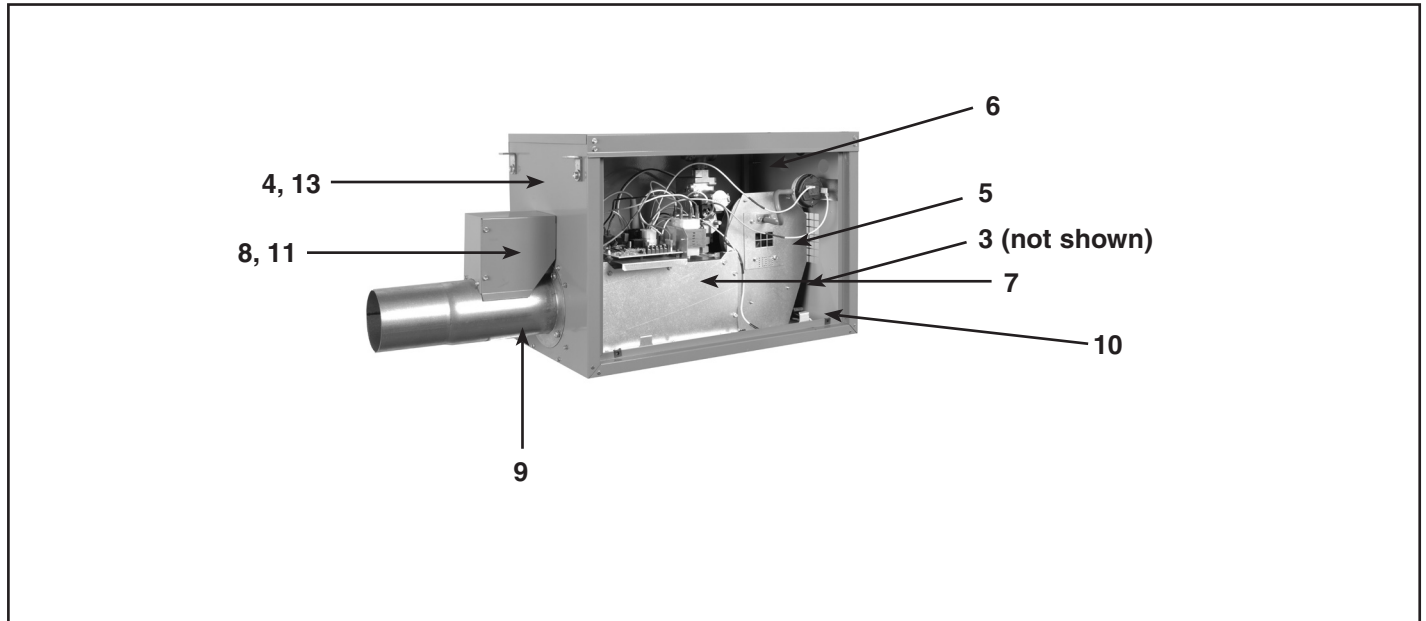

Features	Benefits
1. Heat-treated darkened aluminized steel tubes	1. Heat-treated darkening increases both radiant heat output for more heat near the end of the tube system and eliminates the scratching and flaking that can occur with painted tubes. Aluminized steel provides corrosion resistance for longer life.
2. Polished aluminum reflectors	2. Direct radiant heat from the tubes to the desired area, for increased comfort over wider areas.
3. Removable side-access panels on both sides of the burner box	3. Can be removed completely while accessing either side of the unit.
4. Durable polyester-powder paint	4. Maintains life-long new appearance.
5. Permanently-lubricated combustion blower motor	5. Reduces maintenance.
6. 180 degree-rotating gas valve	6. Allows convenient access from either side of the burner box.
7. Sealed burner compartment	7. Allows manifold pressure adjustments during unit operation, which increases ease of installation and service.
8. Flame sensor and ignitor mounted externally to the combustion chamber	8. Improve service access.
9. Flame observation window on underside of combustion chamber	9. Provides a convenient visual check of unit operation from ground level.
10. Gas valve operation light on back panel on the unit	10. Indicates that the combustion blower is operating.
11. Four-trial separate flame sensor	11. Provides reliable ignition.
12. System approval for vented and common vented installation	12. Maximizes installation flexibility.
13. Weatherproof, water-resistant casing	13. Maximizes application flexibility for both indoor and outdoor installation.
14. ETL design certification	14. Assures that the unit conforms to national safety standards.

Table 7.1 - Performance and Dimensional Data

Model	Gas Controls ③ ④	Input Rating (Btu/hr)		Recommended Mounting Height (ft.) ①		Dimensions (in) ②		Ship Wt. (lbs)	Radiating Area (sq. in.)
				Standard Reflector	Parabolic Reflector	A	B		
		Natural	Propane	30° Angle	30° Angle				
IHR 30	Single Stage or Millivolt	30,000		12 - 14	12 - 15	12 3/4	14 1/4	44	85
IHR 60	Single Stage or Millivolt	60,000		14 - 16	18 - 21	19 1/8	15 1/4	60	170
IHR 90	Single Stage or Millivolt	90,000		16 - 18	21 - 25	26 5/8	15 1/4	81	255
IHR 130	Single Stage or Millivolt	130,000		21 - 24	26 - 32	32	15 1/4	55	340
IHR 160	Single Stage or Millivolt	160,000		24 - 28	29 - 35	38 1/2	15 1/4	65	425

① See Table 8.1 for allowable mounting angles.

② See Figure 7.1.

③ Single stage controls are direct spark ignition with 100% safety shutoff and are available as either 115V or 24V

④ Millivolt thermostat and 35 feet of wire.

Figure 7.1 - Unit Dimensional Drawing

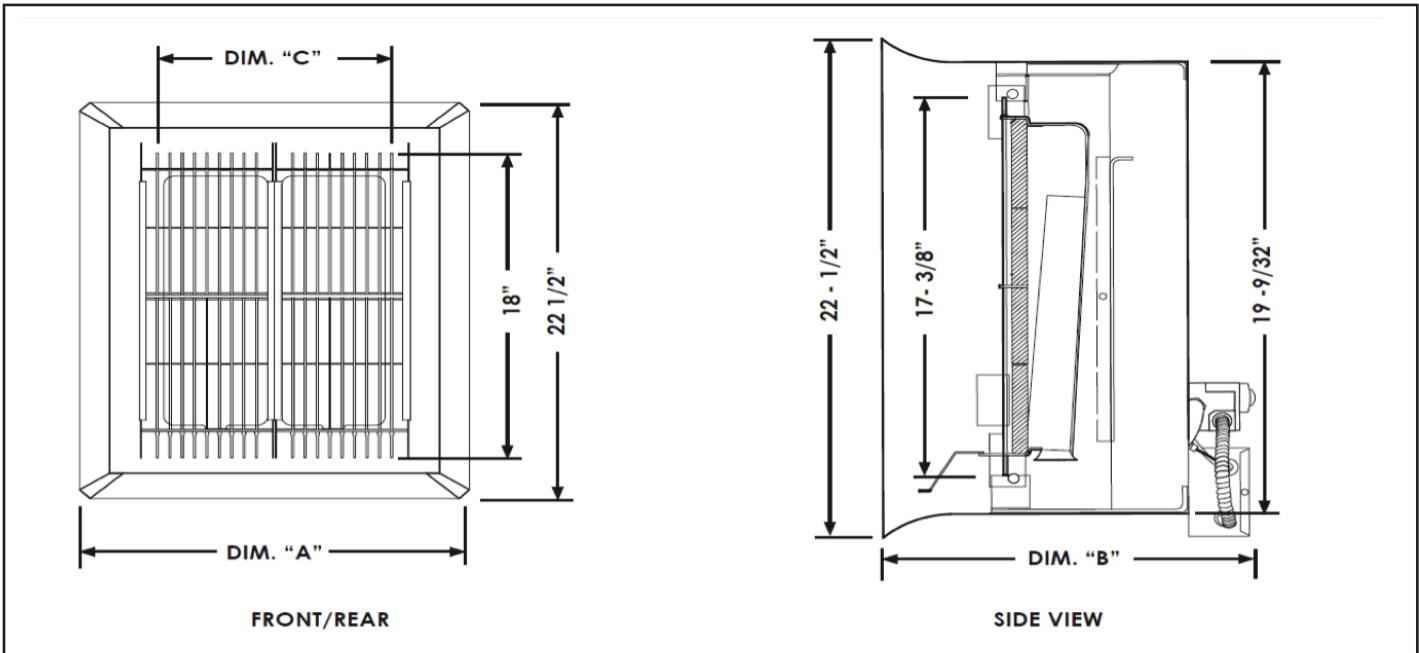

Table 8.1 - Allowable Mounting Angle Range

Model Size	Allowable Mounting Angle Range
30 – 160	20° – 35°

Table 8.2 - Clearances to Combustible Materials (See Figure 8.3)

Model Sizes	30	60	90	130	160
Side of Heater	30	32	48	48	50
Back of Heater	18	18	30	30	32
Top of Heater	28	40	42	52	60
Below Front	72	72 ^①	98	120	132

① Clearance is 80 in. when heater is fitted with a parabolic reflector.

Figure 8.3 - Clearances to Combustibles (See Table 8.2)

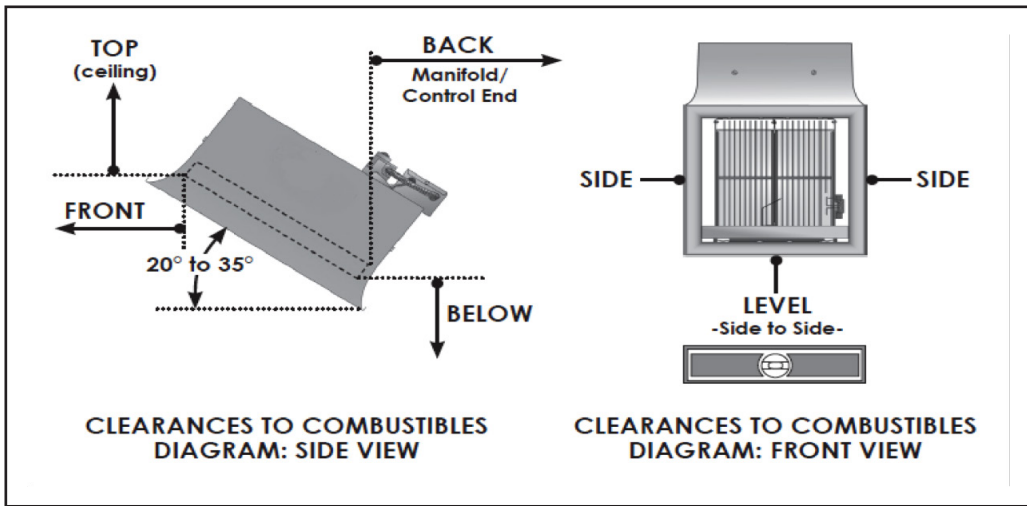

Table 9.1 - Performance and Dimensional Data

Model	Housing	BTU/Hr input	Ship Weight	Recommended Mounting Heights ①	Approx. Area Heated	Control Voltage
OHP 31	430 SS	31,000	59 lbs	8.0' to 12.0'	8' x 8'	24 vac
OHP 34	430 SS	34,000	59 lbs	8.5' to 13.0'	9' x 9'	24 vac

① Clearance is 80 in. when heater is fitted with a parabolic reflector.

Figure 9.1 - Unit Dimensional Drawing

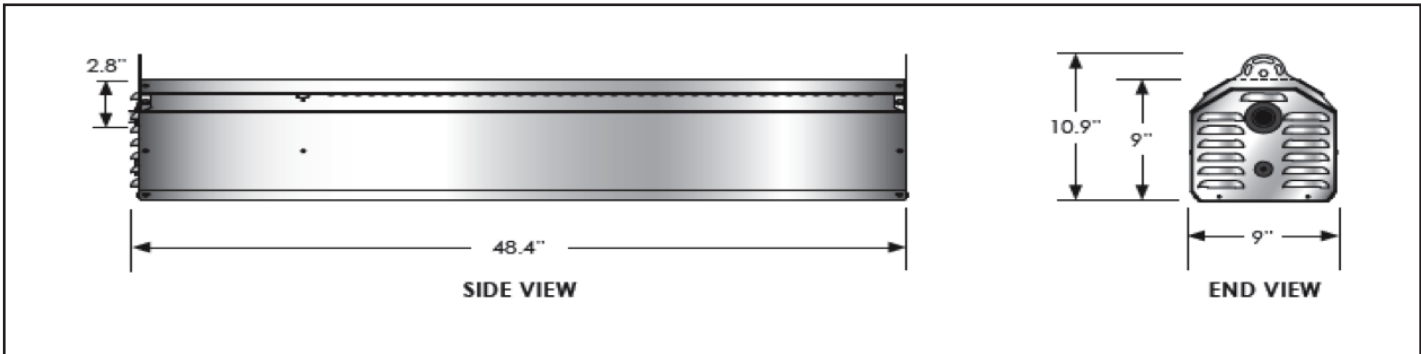

Table 9.2 - Clearances to Combustible Materials

Model Sizes	BTU'Hr	Voltage	Mounting Angle ①	Side	Back	Top	Below	End(s)	Front
31,000 (N,P)	31,000	24 vac	0°	18	N/A	13	48	12	N/A
			30°	N/A	18	18	40	12	36
34,000 (N,P)	34,000	24 vac	0°	18	N/A	13	48	12	N/A
			30°	N/A	18	18	40	12	36

① Heaters mounted on an angle between 1° to 30° must maintain clearances posted for 0° or 30°; whichever is greater.

Figure 9.2 - Clearance to Combustibles

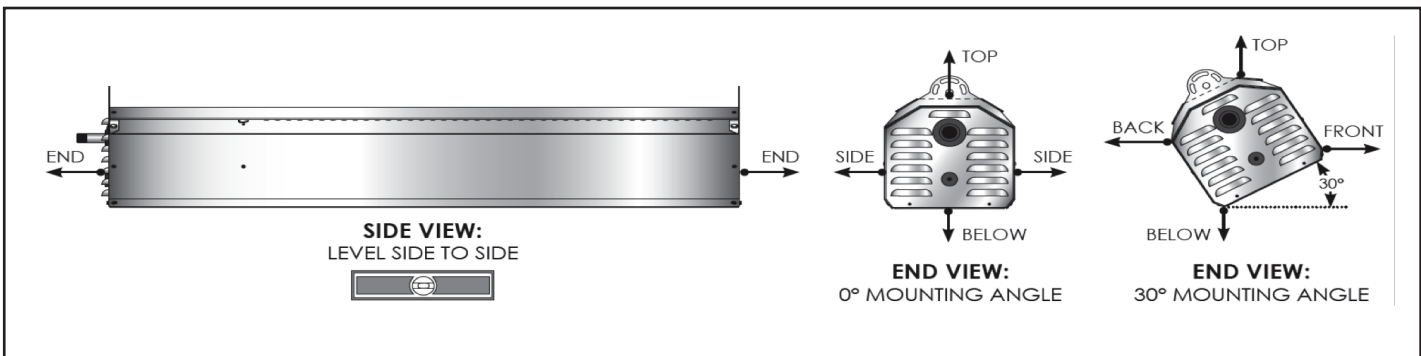

Table 10.1 - Performance

Input MBH	50	60	75	100	125	150	175	200
Certified Tube Lengths (ft.)	20, 30	20, 30, 40	20, 30, 40	30, 40, 50 ②	40, 50, 60	50, 60	50, 60, 70 ③	50, 60, 70 ③
Recommended Mounting Height (ft.) ①	10 - 12	10 - 12	12 - 14	12 - 14	15 - 22	15 - 22	18 - 28	20 - 30
Recommended Tube System Application ①	Spot or Area Heating	U-Tube						
	Total Building Heating	Straight Tube						

① Recommended Mounting Height and Tube System Applications are meant as a general guide and are adjusted to meet the requirements of the actual application. The applications are as follows:

- Spot or Area Heating is an application where occupant comfort is the goal and occupant(s) are either relatively stationary (Spot - Example: small work cell or dispersed over a slightly wider range than with Spot Heating (Area - Example: assembly line). Mounting height is typically at the low end of the range shown above.
- Total Building Heating is an application where average space temperature is to be maintained, however due to the significant temperature gradient differences on long straight tube systems, areas may exist where direct occupant comfort is not achieved.

② IPT 100 not available for Propane Gas operation at 50 ft. tube system length.

③ IPT 75 not available for Propane Gas operation at 40 ft. tube section length.

Table 10.2 - Utilities

Electrical Rating	Gas Connection (inch)	Minimum Gas Inlet Pressure (" W.C.)	Maximum Gas Inlet Pressure ("W.C.)	Manifold Gas Pressure (' W.C.)	Tube/Vent Diameter (inch)
60Hz/1Ph	1/2 NPT	7.0 (natural gas) 11.0 (propane gas)	14.0	3.5 (natural gas-single stage) 2.5 (natural gas-two stage) 10.0 (propane gas-single stage) 6.2 (propane gas-two stage)	4 (O.D.)

Table 10.3 - Combustible Material Clearances ① ② ③

IPT			
Combustible Material Clearances (inches)			
Input MBH	"A" ①	"B" ②	"C" ③
50/60	9	54	20
75/100/125	9	76	24
150/175/200	12	106	38

① Clearance to each end and above the U-Tube is 12 inches.

② In unvented applications, clearance from radiant tube end is 36" in all directions.

③ Refer to Figures 8.1 through 8.3.

Figure 10.2 - Stacking Height

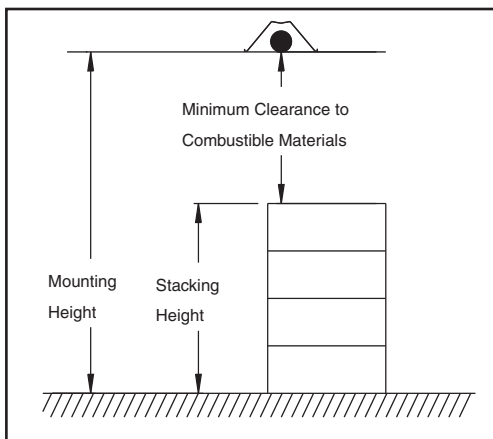

Figure 10.1 - Combustible Material Clearances - Straight Tube

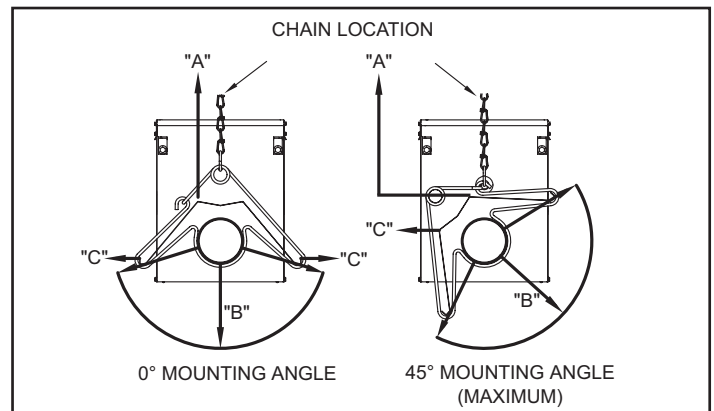

Figure 8.3 - Combustible Material Clearances - U-Tube

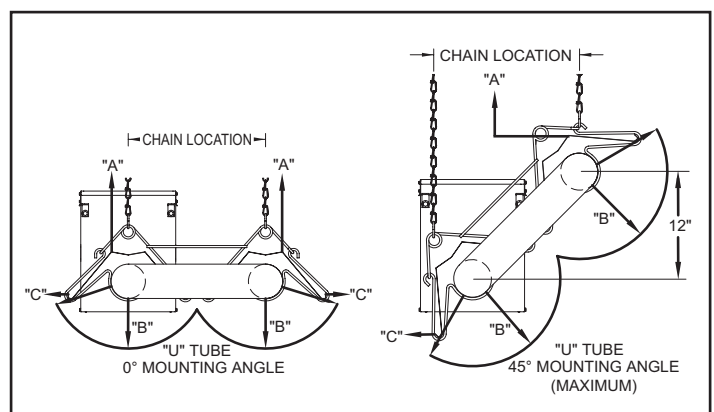

Figure 11.1 - Casing Dimensions

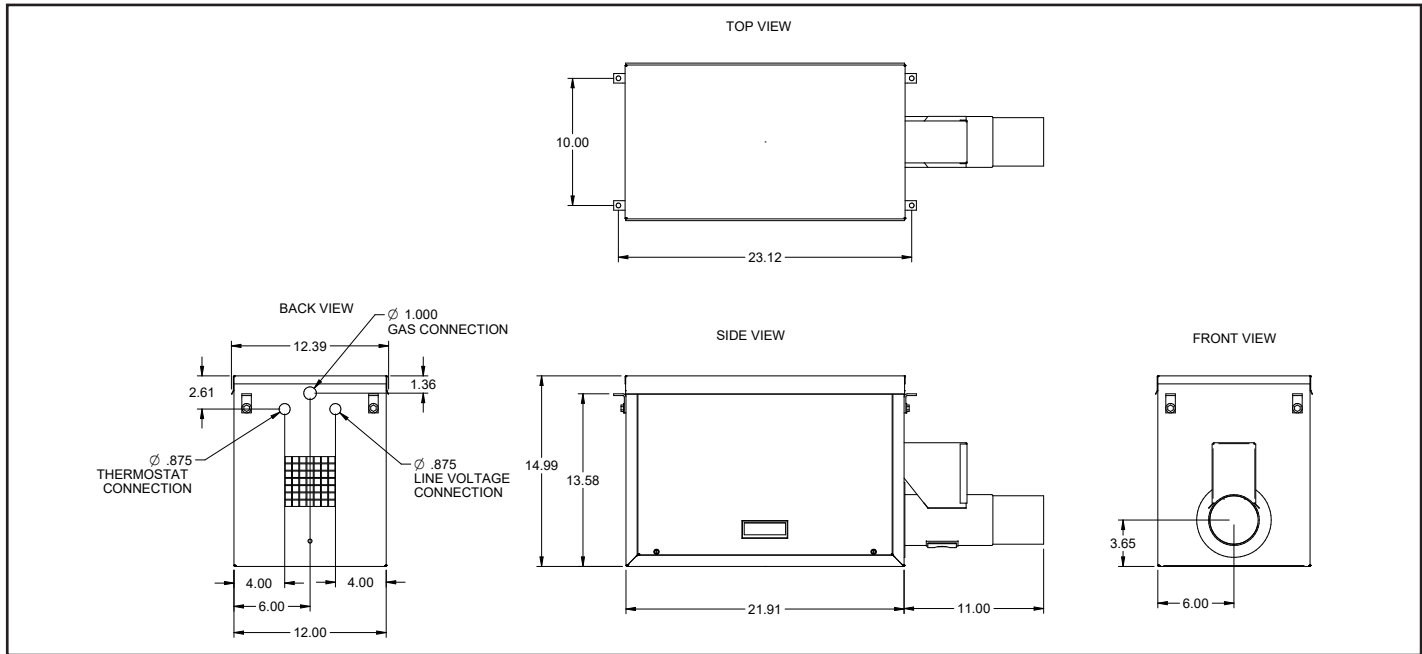

Figure 11.2 - Burner and Tube System Dimensions

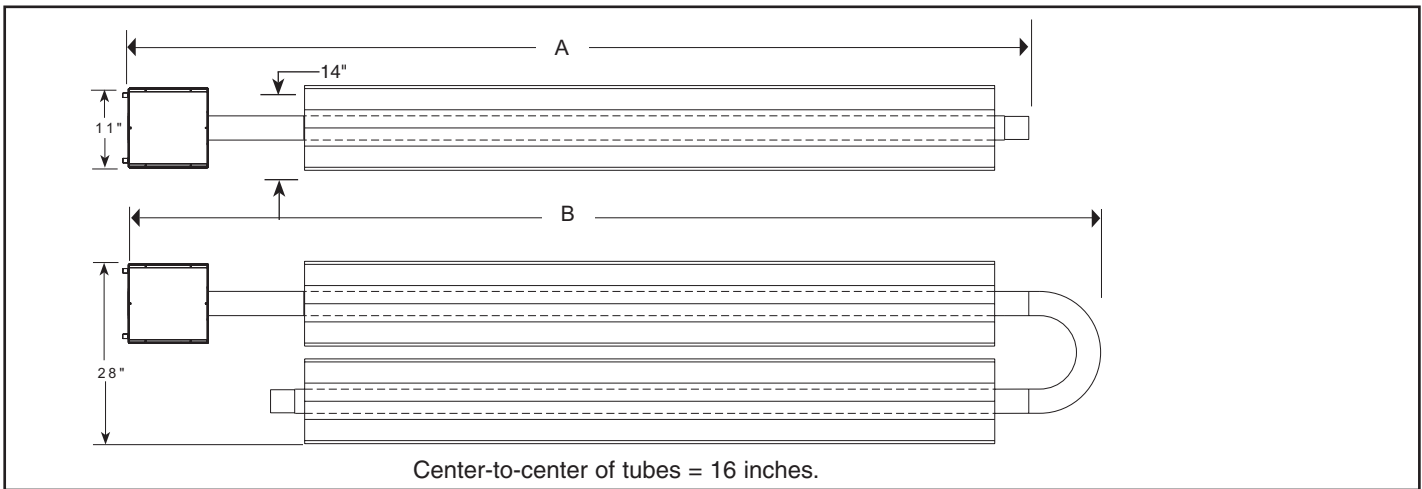

Table 11.1 - Tube Systems Data

Tube Length (ft.)	Straight Tube		U-Tube System	
	System Length "A" (ft.)	System Weight (lb.)	System Length "B" (ft.)	System Weight (lb.)
20	23	78	13	89
30	33	112	18	132
40	43	146	23	157
50	53	180	28	200
60	63	214	33	225
70	73	252	38	277

Table 11.2 - Burner Shipping Weights

Model	Shipping Wt. (lb.)
All Burners	43



General

The heater reflector housing shall be constructed of one-side bright polished aluminum. The emitter shall be composed of a perforated ceramic tile on which combustion takes place on the surface. The burner plenum shall be constructed of aluminized steel of one-piece drawn construction. The heater shall be of a modular design employing multiple burners to achieve the specified input.

- The venturi is constructed of stainless or aluminized steel.
- The secondary re-radiating rods shall be constructed of high temperature stainless steel alloy placed in close proximity of the ceramic burner face.
- Parabolic reflectors shall be used when units are installed in high mounting applications or when focusing of the infrared heating pattern is desirable.
- Protective screens shall be used in facilities where debris may damage the heater.

Burner

The ceramic burner face shall operate at a temperature range of 1660 degrees F to 1810 degrees F and shall incorporate a secondary re-radiating surface of stainless steel rods to obtain optimum operating temperature and radiant output.

Reflectors

The heater reflector housing shall be constructed of one-side bright polished aluminum. The emitter shall be composed of a perforated ceramic tile on which combustion takes place on the surface. The burner plenum shall be constructed of aluminized steel of one-piece drawn construction. The heater shall be of a modular design employing multiple burners to achieve the specified input.

- The venturi is constructed of stainless or aluminized steel.
- The secondary re-radiating rods shall be constructed of high temperature stainless steel alloy placed in close proximity of the ceramic burner face.
- Parabolic reflectors shall be used when units are installed in high mounting applications or when focusing of the infrared heating pattern is desirable.
- Protective screens shall be used in facilities where debris may damage the heater.

Controls

Heater(s) shall be equipped with (check one):

- Heaters shall be equipped with one of the following control systems:

Standing Manual Pilot System with 100% safety shut-off of pilot and main burner in case of pilot outage, operating with no external electrical connection but on milli-voltage generated by the pilot flame (NMV-2 or PMV-2).

Direct Spark Ignition System with direct spark ignition of the main burner through a solid state ignition module operating a spark electrode. Loss of power causes 100% safety shut-off of main burner(s). System operates on 120 or 24 volts (NFS-2 or PFS-2). 24V/60Hz/1ph with 6VA maximum power consumption.

Controls shall be exterior mounted for easy accessibility.

All controls shall be rated for a maximum inlet pressure of 1/2 PSI gas pressure. Controls shall be designed for Natural gas having a specific gravity of 0.60, a Btu content of 1050 Btu/ft³ (Alternate: Propane gas having a specific gravity of 1.53, a Btu content of 2500 Btu/ft³) at 0-2000 feet elevation.

Accessories

The following field installed accessories shall be included (check those that apply):

- Chain mounting set - 5' chain set with 4 "S" hooks. Preset mounting angle of 30°.
- Horizontal parabolic reflector - Directs rays directly downward. Can be used for matching horizontal mounting specifications.
- Full parabolic reflector - Directs rays in a more focused pattern. Typically used in high mounting applications.
- Full parabolic reflector with screen - Directs rays in a more focused pattern. Outer screen protects ceramic grids from objects striking the heater.
- DR heater screen - Screen slips on the outside of the reflectors and protects the ceramic grids.
- Warning plaque - Hung below heater, restates the clearance to combustible warning.

Figure 12.1 - Model Number Designations

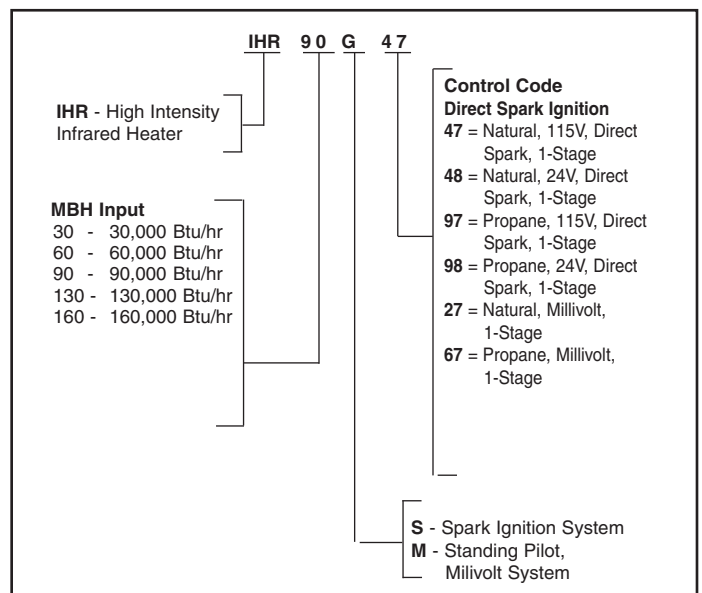



General

Contractor shall furnish and install Modine model _____ low intensity infrared heater(s). The low intensity infrared system shall be straight tube _____, U-tube _____ configuration. Performance shall be as indicated on the equipment schedule in the plans. The infrared heater(s) shall be certified for indoor and outdoor installations. Infrared heater(s) shall have ETL design certification for use in both the US and Canada.

Figure 13.1 - Model Number Designations

DIGIT SEQUENCE	1, 2, 3	4, 5, 6	7	8, 9	10, 11
MODEL NUMBER	IPT	200	S	01	11
MODEL PREFIX: IMPROVED PRESSURE TUBE: IPT	MODEL SIZE: MBH INPUT: 50, 60, 75, 100, 125, 150, 175, 200			CONTROL CODE: 11: SINGLE STAGE, NATURAL GAS 21: SINGLE STAGE, PROPANE GAS 12: TWO STAGE, NATURAL GAS 22: TWO STAGE, PROPANE GAS	
IGNITION TYPE: S: DIRECT SPARK				POWER CODE: 01: 115V/60HZ/1PH	

Casing

The controls, combustion air blower and burner shall be housed in a water-resistant casing, providing weatherproof protection. The burner and control box casing shall be constructed of not less than 20 gauge aluminized steel. After forming, the casing parts shall be cleaned of all oils and a phosphate coating applied prior to painting. The phosphated parts shall then be finished with an electrostatically applied, gray-green polyester powder paint finish. The applied polyester powder paint shall be baked on to provide an attractive finish on all of the exposed casing parts.

Heat Exchanger

The heat exchanger tubes and combustion chamber shall be constructed of 16 gauge, 4" O. D. aluminized steel, and the first combustion tube for gas inputs 150,000 Btuh and greater shall be 16 gauge 4" O. D. 409 Aluminized Stainless Steel. The last heat exchanger tube shall incorporate a turbulator baffle for maximum efficiency of heat transfer.

The heat exchanger tubes must be used in conjunction with reflectors. The reflector can be adjusted from 0° to 45° from the horizontal plane. Reflectors shall be of bright polished aluminum.

Controls

Input power to the infrared heater(s) shall be 115V/60Hz/1ph. Heater(s) shall be equipped with a direct four-trial (three re-trial), 100% shut-off electronic ignition control system with a separate flame sensor. Infrared heater(s) shall be equipped with a 115V/25V control transformer. Thermostat shall operate on 25V. Heater(s) will be equipped with a pre-purge mode, a differential pressure switch, and an indicator light to prove proper operation of the gas valve. All controls shall be rated for a maximum inlet pressure of 1/2 PSI gas pressure.

Controls shall be designed for natural _____, propane _____ gas having a specific gravity of _____, a Btu content of _____ Btu/ft³ at _____ feet elevation.

Motor

Each heater shall have a single motor. The combustion air blower motor shall be totally enclosed in the control box and the motor shall be protected by a thermal overload switch. The motor shall be .03 H.P., 115 volt, 60 Hz, single phase, with an operating speed of 3000 rpm.

Products from Modine are designed to provide indoor air-comfort and ventilation solutions for residential, commercial, institutional and industrial applications. Whatever your heating, ventilating and air conditioning requirements, Modine has the product to satisfy your needs, including:

HVAC

- Unit Heaters:
 - Gas
 - Hydronic
 - Electric
 - Oil
- Ceiling Cassettes
- Duct Furnaces
- Hydronic Cabinet Unit Heaters, Fin Tube, Convectors
- Infrared Heaters
- Make-up Air Systems
- Unit Ventilators

Ventilation

- Packaged Rooftop Ventilation

School Products

- Vertical Packaged Classroom HVAC:
 - DX Cooling/Heat Pump
 - Water/Ground Source Heat Pump
 - Horizontal/Vertical Unit Ventilators

Specific catalogs are available for each product. Catalogs 75-136 and 75-137 provide details on all Modine HVAC equipment.



Modine Manufacturing Company

1500 DeKoven Avenue
Racine, Wisconsin 53403-2552
Phone: 1.800.828.4328 (HEAT)
www.modinehvac.com

© Modine Manufacturing Company 2019