

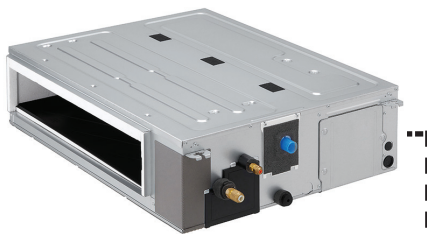

SINGLE-ZONE CONVERTIBLE MID-STATIC DUCTED INSTALLATION MANUAL

**Single-Zone Convertible
Mid-Static Ducted
Heat Pump Systems
3/4 to 2 Tons**



**LH098HV1 (9,000 Btu/h)
LH128HV1 (12,000 Btu/h)**

**LH188HV1 (18,000 Btu/h)
LH248HV1 (24,000 Btu/h)**

PROPRIETARY DATA NOTICE

This document, as well as all reports, illustrations, data, information, and other materials are the property of LG Electronics U.S.A., Inc., and are disclosed by LG Electronics U.S.A., Inc., only in confidence.

This document is for design purposes only.

Do not throw away, destroy, or lose this manual.

Please read carefully and store in a safe place for future reference.

Content familiarity required for proper installation.

The instructions included in this manual must be followed to prevent product malfunction, property damage, injury, or death to the user or other people. Incorrect operation due to ignoring any instructions will cause harm or damage. The level of seriousness is classified by the symbols described below.

A summary list of safety precautions begins on page 3.

For more technical materials such as submittals, engineering databooks, and catalogs, visit www.lghvac.com.

Proper sizing and installation of equipment is critical to achieve optimal performance. Split system air conditioners and heat pumps (excluding ductless systems) must be matched with appropriate coil components to meet ENERGY STAR® criteria. Ask your contractor for details or visit www.energystar.gov.

(ENERGY STAR and the ENERGY STAR mark are registered trademarks owned by the U.S. Environmental Protection Agency.)

IMPORTANT - This product has been designed and manufactured to meet ENERGY STAR criteria for energy efficiency when matched with appropriate coil components. However, proper refrigerant charge and proper air flow are critical to achieve rated capacity and efficiency. Installation of this product should follow the manufacturer's refrigerant charging and air flow instructions. **Failure to confirm proper charge and airflow may reduce energy efficiency and shorten equipment life.**

For continual product development, LG Electronics U.S.A., Inc., reserves the right to change specifications without notice.





©LG Electronics U.S.A., Inc.

This document, as well as all reports, illustrations, data, information, and other materials are the property of LG Electronics U.S.A., Inc.

SAFETY INSTRUCTIONS

The instructions below must be followed to prevent product malfunction, property damage, injury or death to the user or other people. Incorrect operation due to ignoring any instructions will cause harm or damage. The level of seriousness is classified by the symbols described below.

TABLE OF SYMBOLS

 DANGER	<i>This symbol indicates an imminently hazardous situation which, if not avoided, will result in death or serious injury.</i>
 WARNING	<i>This symbol indicates a potentially hazardous situation which, if not avoided, could result in death or serious injury.</i>
 CAUTION	<i>This symbol indicates a potentially hazardous situation which, if not avoided, may result in minor or moderate injury.</i>
 NOTE	<i>This symbol indicates situations that may result in equipment or property damage accidents only.</i>
Note:	<i>This symbol indicates information related to the current procedure.</i>
	<i>This symbol indicates an action that should not be performed.</i>

INSTALLATION

DANGER

 **Don't store or use flammable gas / combustibles near the unit.**

There is risk of fire, explosion, and physical injury or death.

Use only an appropriately sized vacuum pump and / or inert (nitrogen) gas when performing leak tests or purging air.  **Do not use compressed compress air, oxygen, or flammable gases.**

There is risk of fire, explosion, and physical injury or death.

WARNING

 **Do not install or remove the unit by yourself (end user). Ask the dealer or an LG trained service provider to install the unit.**

Improper installation by the user will result in water leakage, fire, explosion, electric shock, physical injury or death.

Always check for system refrigerant leaks during installation and after the unit has been installed or serviced.

Exposure to high concentration levels of refrigerant gas will lead to illness or death.

Wear protective gloves when handling equipment. Sharp edges will cause personal injury.

For replacement of an installed unit, always contact an LG trained service provider.  Do not randomly disassemble or repair the units.

There is risk of fire, electric shock, explosion, and physical injury or death.

Dispose the packing materials safely.

- *Packing materials, such as nails and other metal or wooden parts, will cause puncture wounds or other injuries.*
- *Tear apart and throw away plastic packaging bags so that children do not play with them and risk suffocation and death.*

The unit is shipped with refrigerant and the service valves closed.  Do not open service valves on the unit until all non-condensibles have been removed from the piping system and authorization to do so has been obtained from the commissioning agent.

There is a risk of physical injury or death.

Install the unit considering the potential for strong winds or earthquakes.

Improper installation will cause the unit to fall over, resulting in physical injury or death.

 **Do not run the compressor with the service valves closed.**

There is a risk of explosion, physical injury, or death.

 **Do not change the settings of the protection devices.**

If the pressure switch, thermal switch, or other protection device is shorted and forced to operate improperly, or parts other than those specified by LG are used, there is risk of fire, electric shock, explosion, and physical injury or death.

Periodically check that the outdoor frame is not damaged.

There is a risk of explosion, physical injury, or death.

When installing the mid-static ducted indoor unit vertically, the vertical drain pan (in the conversion kit) must be installed.

If the conversion kit / vertical drain pan is not used, water will leak, causing a slippery surface that creates a risk of slipping, falling, and injury.

Replace all control box covers.

If control box covers are not installed securely, dust, water and animals will enter the unit, causing fire, electric shock, and physical injury or death.

SAFETY INSTRUCTIONS

INSTALLATION - CONTINUED

⚠ WARNING

If the air conditioner is installed in a small space, take measures to prevent the refrigerant concentration from exceeding safety limits in the event of a refrigerant leak. Consult the latest edition of ASHRAE (American Society of Heating, Refrigerating, and Air Conditioning Engineers) Standard 15. If the refrigerant leaks and safety limits are exceeded, it could result in personal injuries or death from oxygen depletion.

⊘ Do not install the unit on a defective stand.
There is a risk of physical injury.

⚠ CAUTION

Be very careful when transporting the product. Failure to follow these directions will result in minor or moderate physical injury.

- ⊘ Do not attempt to carry the product without assistance.
- Some products use polypropylene bands for packaging. ⊘ Do not use polypropylene bands to lift the unit.
- Suspend the unit from the base at specified positions.
- Support the unit a minimum of four points to avoid slippage from rigging apparatus.

⚠ NOTE

⊘ Don't install the unit where it's directly exposed to ocean winds.
Ocean winds will cause corrosion, particularly on the condenser and evaporator fins, which, in turn could cause product malfunction or inefficient performance.

When installing the unit in a low-lying area, or a location that is not level, use a raised concrete pad or concrete blocks to provide a solid, level foundation.
This will prevent water damage and reduce abnormal vibration.

Properly insulate all cold surfaces to prevent "sweating."
Cold surfaces such as uninsulated piping can generate condensate that will drip and cause a slippery surface condition and/or water damage to walls.

When installing the unit in a hospital, mechanical room, or similar electromagnetic field (EMF) sensitive environment, provide sufficient protection against electrical noise.
Inverter equipment, power generators, high-frequency medical equipment, or radio communication equipment will cause the air conditioner to operate improperly. The unit will also affect such equipment by creating electrical noise that disturbs medical treatment or image broadcasting.

⊘ Do not use the product for special purposes such as preserving foods, works of art, wine coolers, or other precision air conditioning applications. The equipment is designed to provide comfort cooling and heating.
There is risk of property damage.

⊘ Do not make refrigerant substitutions. Use R410A only.
If a different refrigerant is used, or air mixes with original refrigerant, the unit will malfunction and be damaged.

Install the unit in a safe location where nobody can step on or fall onto it.
There is risk of physical injury or death.

Properly insulate all cold surfaces to prevent "sweating."
Cold surfaces such as uninsulated piping can generate condensate that could drip, causing a slippery surface that creates a risk of slipping, falling, and personal injury.

Keep the unit upright and parallel during installation to avoid vibration or water leakage.

⊘ Do not install the unit in a noise sensitive area.
When connecting refrigerant tubing, remember to allow for pipe expansion.
Improper piping will cause refrigerant leaks and system malfunction.

Take appropriate actions at the end of HVAC equipment life to recover, recycle, reclaim or destroy R410A refrigerant according to applicable U.S. Environmental Protection Agency (EPA) rules.

Periodically check that the outdoor frame is not damaged.
There is a risk of equipment damage.

Install the unit in a safe location where nobody can step on, fall onto, or place items on it. ⊘ Do not install the unit on a defective stand.
There is risk of unit and property damage.

Install the drain hose to ensure adequate drainage.
There is a risk of water leakage and property damage.

⊘ Don't store or use flammable gas / combustibles near the unit.
There is risk of product failure.

Always check for system refrigerant leaks after the unit has been installed or serviced.
Low refrigerant levels will cause product failure.

SAFETY INSTRUCTIONS

INSTALLATION - CONTINUED

⚠ NOTE

When installing the mid-static ducted indoor unit vertically, the vertical drain pan (in the conversion kit) must be installed.

If the conversion kit / vertical drain pan is not used, water will leak and cause a slippery surface condition and/or water damage to walls.

The unit is shipped with refrigerant and the service valves closed. ⚠ Do not open service valves on the unit until all non-condensibles have been removed from the piping system and authorization to do so has been obtained from the commissioning agent.

There is a risk of refrigerant contamination, refrigerant loss and equipment damage.

⚠ Do not run the compressor with the service valves closed. *There is a risk of equipment damage.*

Ensure the ductwork and its material follow local, state, and federal codes for supplying / circulating air.

There is risk of product failure and / or damage.

WIRING

⚠ DANGER

High voltage electricity is required to operate this system. Follow the National Electrical Codes and these instructions when wiring.

Improper connections and inadequate grounding can cause accidental injury or death.

Always ground the unit following local, state, and National Electrical Codes.

Turn the power off at the nearest disconnect before servicing the equipment.

Electrical shock can cause physical injury or death.

Properly size all circuit breakers or fuses.

There is risk of fire, electric shock, explosion, physical injury or death.

⚠ WARNING

The information contained in this manual is intended for use by an industry-qualified, experienced, certified electrician familiar with the U.S. National Electric Code (NEC) who is equipped with the proper tools and test instruments.

Failure to carefully read and follow all instructions in this manual can result in personal injury or death.

All electric work must be performed by a licensed electrician and conform to local building codes or, in the absence of local codes, with the National Electrical Code, and the instructions given in this manual.

If the power source capacity is inadequate or the electric work is not performed properly, it will result in fire, electric shock, physical injury or death.

Refer to local, state, and federal codes, and use power wires of sufficient current capacity and rating.

Wires that are too small will generate heat and cause a fire.

Secure all field wiring connections with appropriate wire strain relief.

Improperly securing wires will create undue stress on equipment power lugs. Inadequate connections will generate heat, cause a fire and physical injury or death.

⚠ NOTE

The information contained in this manual is intended for use by an industry-qualified, experienced, certified electrician familiar with the U.S. National Electric Code (NEC) who is equipped with the proper tools and test instruments.

Failure to carefully read and follow all instructions in this manual can result in equipment malfunction and property damage.

SAFETY INSTRUCTIONS

OPERATION

⚠ DANGER

- ⊘ Do not provide power to or operate the unit if it is flooded, submerged, or emits unusual operating sounds, smells, or smoke.

There is risk of fire, electric shock, physical injury or death.

Use a dedicated power source for this product.

There is risk of fire, electric shock, physical injury or death.

- ⊘ Do not operate the disconnect switch with wet hands.

There is risk of fire, electric shock, physical injury or death.

Periodically verify that the hardware securing the unit has not deteriorated.

If the unit falls from its installed location, it can cause property damage, product failure, physical injury or death.

If gas leaks out, ventilate the area before operating the unit.

If the unit is mounted in an enclosed, low-lying, or poorly ventilated area, and the system develops a refrigerant leak, it will cause fire, electric shock, explosion, physical injury or death.

⚠ WARNING

- ⊘ Do not allow water, dirt, or animals to enter the unit.

There is risk of fire, electric shock, physical injury or death.

- ⊘ Avoid excessive cooling, and periodically perform ventilation to the unit.

Inadequate ventilation is a health hazard.

- ⊘ Do not touch the refrigerant piping during or after operation.

It can cause burns or frostbite.

- ⊘ Do not operate the unit with the panel(s) or protective cover(s) removed; keep fingers and clothing away from moving parts.

The rotating, hot, cold, and high-voltage parts of the unit can cause physical injury or death.

Periodically verify the equipment mounts have not deteriorated.

If the base collapses, the unit could fall and cause physical injury or death.

- ⊘ Do not open the inlet grille of the unit during operation.
- ⊘ Do not operate the unit with the panels or guards removed.
- ⊘ Do not insert hands or other objects through the inlet or outlet when the unit is plugged in.
- ⊘ Do not touch the metal parts of the unit when removing the filter.

The unit contains sharp, rotating, hot, and high voltage parts that can cause personal injury and/or electric shock.

Securely attach the electrical part cover to the indoor unit and the service panel to the outdoor unit.

Non-secured covers can result in burns or electric shock due to dust or water in the service panel.

⚠ CAUTION

- ⊘ To avoid physical injury, use caution when cleaning or servicing the air conditioner.

⚠ NOTE

Clean up the site after installation is finished, and check that no metal scraps, screws, or bits of wiring have been left inside or surrounding the unit.

- ⊘ Do not use this equipment in mission critical or special-purpose applications such as preserving foods, works of art, wine coolers or refrigeration. The equipment is designed to provide comfort cooling and heating.

- ⊘ Do not block the inlet or outlet.

Unit will malfunction.

Use a soft cloth to clean the units. Do not use wax, thinner, or strong detergents.

The exterior of the units may deteriorate, change color, or may be damaged if harsh cleaning chemicals are used.

Securely attach the electrical part cover to the indoor unit and the service panel to the outdoor unit.

Non-secured covers can result in malfunction due to dust or water in the service panel.

Periodically verify the equipment mounts have not deteriorated.

If the base collapses, the unit could fall and cause property damage or product failure.

- ⊘ Do not allow water, dirt, or animals to enter the unit.

There is risk of unit failure.

TABLE OF CONTENTS

Safety Instructions	3-6	Electrical System Installation	48-58
General Data	8-14	<i>Safety Guidelines</i>	48
<i>Unit Nomenclature</i>	8	<i>Connections and Specifications</i>	48-51
<i>Convertible Mid-Static Ducted Mid Static Pairing Table</i>	9	<i>Wired Controller Connections</i>	52-54
<i>Parts</i>	10	<i>Indoor Unit Electrical Connections</i>	55
<i>Optional Accessory</i>	11	<i>Vertical Installation Conversion Kit Wiring</i>	56
<i>Convertible Mid-Static Ducted Specifications</i>	12-13	<i>Using a Conduit</i>	56
<i>Electrical</i>	14	<i>Connecting ODU Wiring</i>	57-58
General Installation Guidelines	15-28	Final Installation Procedures	59-75
<i>Outdoor Unit Location Selection</i>	15-17	<i>Triple Leak / Pressure Test</i>	59-60
<i>Required Outdoor Unit Clearances</i>	18	<i>Deep Evacuation Tests</i>	60-61
<i>Rigging and Lifting / Outdoor Unit Mounting</i>	19	<i>Triple Evacuation Tests</i>	61-62
<i>Outdoor Unit Mounting</i>	20	<i>Refrigerant Trim Charge, Finishing the Job</i>	63
<i>IDU Location Selection / Required IDU Clearances</i>	21	<i>Installer Setting Mode</i>	64
<i>Indoor Unit Bolt Locations</i>	22	<i>Setting the External Static Pressure</i>	65-66
<i>Required Service Space / Prep. for Horizontal Install</i>	23	<i>FC-15 / FC-35</i>	67
<i>Hanging the Indoor Unit for Horizontal Install</i>	24	<i>Test Run</i>	68
<i>Vertical Installation</i>	25	<i>Performance Evaluation</i>	69
<i>Installing for Cond. Drainage / Drilling the Piping Hole</i>	26	<i>LHN098-248HV1 Indoor Unit DIP Switch Settings</i>	70
<i>Vertical Conversion Kit Installation</i>	27	<i>Setting LUU180-240HV Optional Modes</i>	71-75
<i>Changing the Inlet Position</i>	28	Troubleshooting	76-81
General Refrigerant Piping System Information	29-38	<i>LG Monitoring View (LGMV) Diagnostic Software</i>	76-77
<i>Refrigerant Safety Standards</i>	29	<i>LG ThinQ</i>	78
<i>Device Connection Limitations</i>	29	<i>Error Codes</i>	79-80
<i>Selecting Field Supplied Piping</i>	30	<i>Refrigerant Leaks</i>	81
<i>Copper Expansion and Contraction</i>	31-32	Installation Checklist	82
<i>Piping Handling</i>	33		
<i>Refrigerant System Engineering</i>	34-36		
<i>Flaring and Brazing Procedures</i>	37-38		
Refrigerant Piping Connections	39-47		
<i>Installation Overview / Special Applications</i>	39		
<i>Outdoor Unit Connections</i>	40		
<i>Indoor Unit Connections</i>	41		
<i>ODU Condensate Piping / IDU Condensate Piping</i>	42		
<i>Vertical Condensate Piping / Common Drain System</i>	43		
<i>Gravity Condensate Pipe / Checking for Leaks</i>	44		
<i>Bundling</i>	45		
<i>Insulation</i>	46-47		

GENERAL DATA

Unit Nomenclature

Indoor Units and Outdoor Units

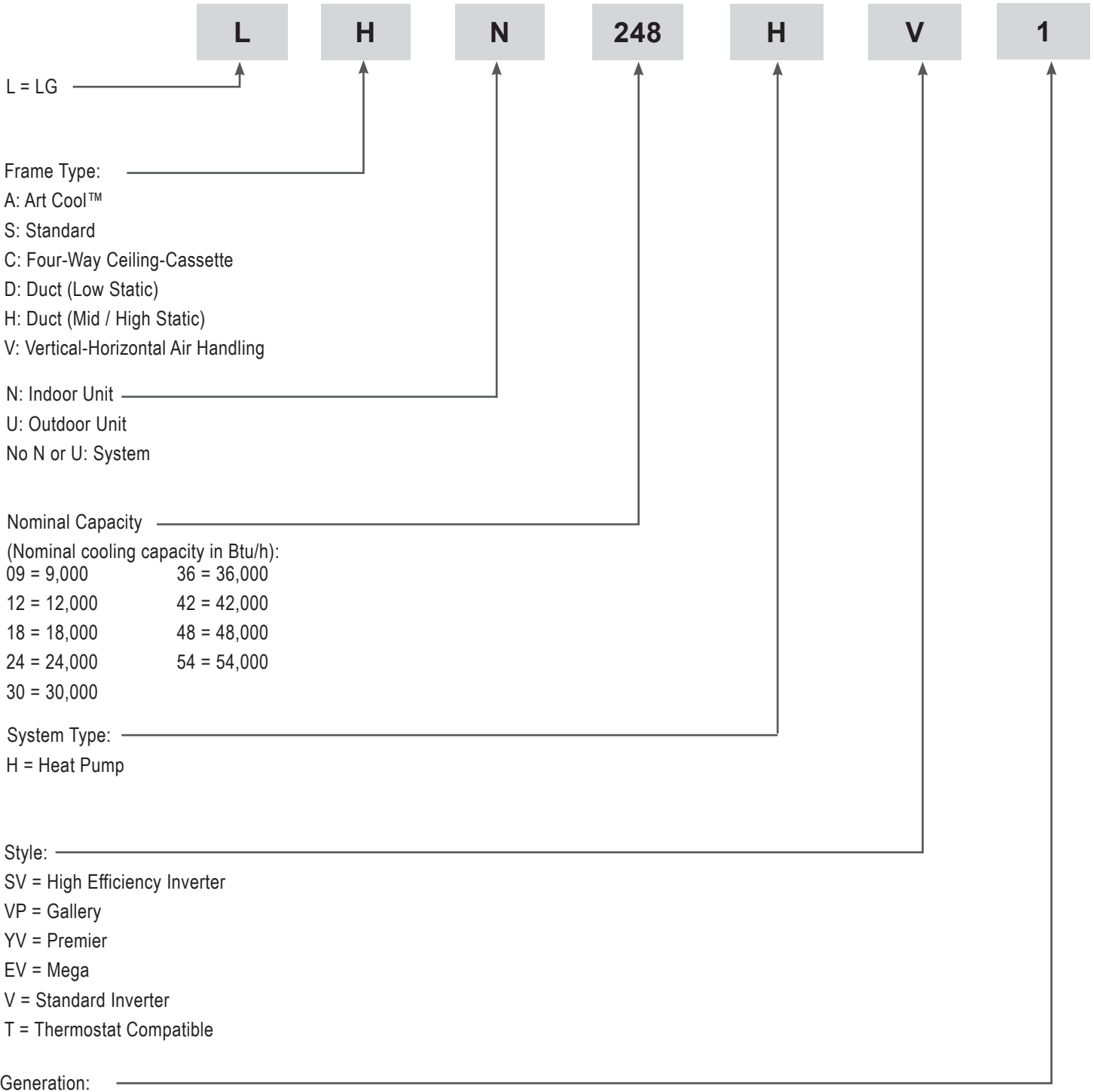





Single-Zone Convertible Mid-Static Ducted Installation Manual

GENERAL DATA

Convertible Mid-Static Ducted Mid Static Pairing Table

The following table shows the available outdoor and indoor units.

Table 1: Convertible Mid-Static Ducted System Pairing Table

Outdoor Unit Model	Indoor Unit Model
<p data-bbox="99 470 207 497">Mid Static</p> <p data-bbox="212 499 456 527">LUU090HV - LUU120HV</p> 	<p data-bbox="678 499 943 527">LHN098HV1 - LHN128HV1</p> 
<p data-bbox="212 795 456 823">LUU180HV - LUU240HV</p> 	<p data-bbox="678 795 943 823">LHN188HV1 - LHN248HV1</p> 

Note:

The above units require any LG wired remote controller for operation. The LG wired remote controller is sold separately.

GENERAL DATA

Parts

Convertible Mid-Static Ducted Indoor Unit

Figure 1: Convertible Mid-Static Ducted Indoor Unit Front and Back Views.

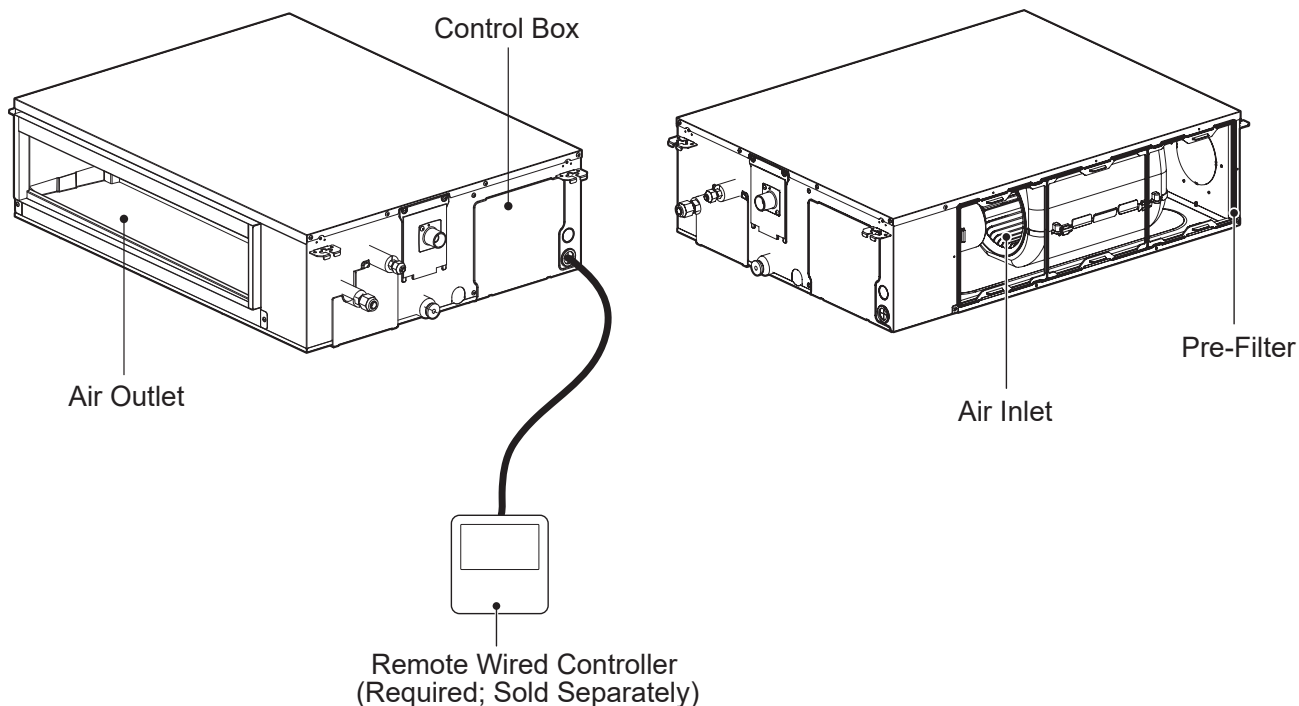





Required Parts (field provided)

- Connecting cable (power and control)
- Pipes - vapor line and liquid line, with insulation
- 3/8" or 1/2" threaded hanger rods
- 3/8" or 1/2" nuts, flat washers, and lock / split washers
- Secondary (optional) drain hose
- Insulation for secondary (optional) drain hose

Included Parts

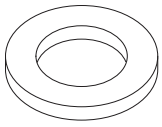
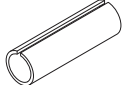
Table 2: Included Items.

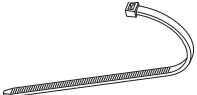
Part	Quantity	Image	Part	Quantity	Image
Drain Hose	One (1)		Metal Clamp	Two (2)	
Vinyl	One (1)		Washers for Hanging Bracket	Eight (8)	
Insulation for Fittings	One (1) Set	 For Vapor Piping  For Liquid Piping	Cable Ties	Four (4)	

Optional Accessory

Mid-Static Ducted Vertical Installation Conversion Kit (Sold Separately)

The Mid-Static Ducted Vertical Installation Conversion Kit **MUST** be purchased (sold separately) and applied to install the mid-static ducted indoor unit vertically.

Figure 2: Mid-Static Ducted Vertical Installation Options.

Option 1. Floor Installation

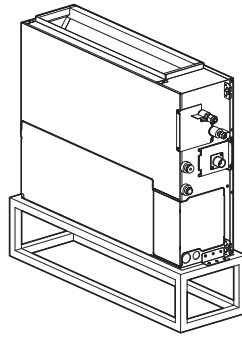

Option 2. Wall Installation

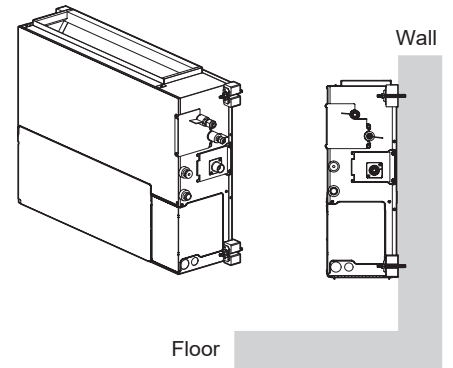

Table 3: Optional Accessory Table.

Model Number	Description	Quantity
ABDAMA0	Mid-Static Ducted Vertical Installation Conversion Kit	One (1)

Table 4: Optional Accessory Parts (Included with the conversion kit).

Part	Quantity	Image	Part	Quantity	Image	Part	Quantity	Image
Vertical Drain Pan Assembly	One (1)		D4 / L10 Screws	Five (5)		Vertical Installation Manual	One (1)	
Metal Mesh	One (1)		Washers	Four (4)		Caution Label	Two (2)	
CN_FLOAT Molex Connector	One (1)		Bushings	Four (4)				
CN_D_PUMP Molex Connector	One (1)		M10 Nuts	Four (4)				

⚠ WARNING

When installing the mid-static ducted indoor unit vertically, the mesh steel provided **MUST** be installed to avoid injury from moving parts.

Note:

Parts required will be different depending if the installation is on the floor or the wall.

GENERAL DATA

Convertible Mid-Static Ducted Specifications

Table 5: Convertible Mid-Static Ducted System General Data.

Type	Single-Zone Convertible Mid-Static Ducted	
System (Model) (Indoor Unit / Outdoor Unit)	LH098HV1 (LHN098HV1 / LUU090HV)	LH128HV1 (LHN128HV1 / LUU120HV)
Cooling Capacity (Min / Rated / Max) (Btu/h)	3,600 ~ 9,000 ~ 10,700	4,640 ~ 12,000 ~ 14,000
Cooling Power Input ¹ (kW)	0.20 ~ 0.76 ~ 1.13	0.26 ~ 1.03 ~ 1.44
EER2 @95°F	11.80	11.70
SEER2	16.00	16.00
Heating Capacity (Min / Rated / Max) (Btu/h)	5,600 ~ 13,500 ~ 16,000	6,400 ~ 15,000 ~ 17,800
Heating Power Input ¹ (kW)	0.26 ~ 1.06 ~ 1.59	0.37 ~ 1.27 ~ 1.76
COP @47°F	3.73	3.46
HSPF2	10.40	10.50
ENERGY STAR 6.1 / Cold Climate	Yes / Yes	Yes / Yes
Power Supply V, Ø, Hz ²	208-230 / 1 / 60	
Power Wiring / Communications Cable (No. x AWG) ²	4 x 14	
Rated Low Heating Capacity (Btu/h)		
Outdoor 17°F (WB) / Indoor 70°F (DB)	9,300	10,400
Low COP @17°F	2.87	2.8
Maximum Heating Capacity (Btu/h)		
Outdoor 17°F (DB) / Indoor 70°F (DB)	11,700	13,100
Outdoor 5°F (DB) / Indoor 70°F (DB)	11,000	11,000
Outdoor -4°F (DB) / Indoor 70°F (DB)	10,260	9,410
Outdoor Unit Operating Range		
Cooling (°F DB)	0 to 118	
Optional Wind Baffle Cooling (°F DB)	Yes (-4)	
Heating (°F WB)	-4 to 64	
Indoor Unit Operating Range		
Cooling (°F WB)	57 to 77	
Heating (°F DB)	59 to 81	
Indoor Temperature Setting Range		
Cooling (°F)	65 to 86	
Heating (°F)	61 to 86	
Unit Data		
Refrigerant Type ³	R410A	
Refrigerant Control	EEV	
Indoor Unit Sound Pressure Level ±1 dB(A) (H/M/L) ⁴	28 / 27 / 26	31 / 29 / 28
Outdoor Unit Sound Pressure Level ±1 dB(A) (Cool/Heat) ⁴	47 / 51	49 / 52
Indoor Unit Net / Shipping Weight (lbs.)	61.5 / 71.7	61.5 / 71.7
Outdoor Unit Net / Shipping Weight (lbs.)	71 / 76	71 / 76
Vertical Installation Kit Net / Shipping Weight (lbs.)	4.41 / 5.95	4.41 / 5.95
Compressor (Type x Qty.)	Twin Rotary x 1	
Dehumidification Rate (pts./hr.)	0.85	1.44
Fan		
Indoor Unit Type x Qty.	Sirocco x 1	Sirocco x 1
Outdoor Unit Type x Qty.	Propeller x 1	Propeller x 1
Motor / Drive	Brushless Digitally Controlled / Direct	
Airflow Rate		
Indoor Unit (Max. / H / M / L [CFM])	353.1 / 317.8 / 282.5	494.4 / 423.8 / 353.1
Outdoor Unit (Max. CFM)	988	988
IDU Factory Set (High) External Static Pressure (in. wg)	0.24	
ODU Factory Set (High) External Static Pressure (in. wg)	0.1	
Piping		
Liquid (in.) (Connection size / Pipe size)	1/4 / 1/4	1/4 / 1/4
Vapor (in.) (Connection size / Pipe size)	3/8 / 3/8	3/8 / 3/8
Indoor Unit Condensate Drain O.D. / I.D. (in.)	1-1/4 / 31/32	
Additional Refrigerant Charge (oz./ft.)	0.22	
Pipe Length (Minimum/Maximum, ft.)	16.4 / 66	
Piping Length (no additional refrigerant, ft.)	24.9	
Maximum Elevation Difference (ft.)	49	

EEV: Electronic Expansion Valve, IDU: Indoor Unit, ODU: Outdoor Unit. This unit comes with a dry helium charge.

This data is rated 0 ft above sea level, with 24.6 ft of refrigerant line per indoor unit and a 0 ft level difference between outdoor and indoor units.

Cooling capacity rating obtained with air entering the indoor coil at 80°F dry bulb (DB) and 67°F wet bulb (WB); and outdoor ambient conditions of 95°F dry bulb (DB) and 75°F wet bulb (WB). Heating capacity rating obtained with air entering the indoor unit at 70°F dry bulb (DB) and 60°F wet bulb (WB); and outdoor ambient conditions of 47°F dry bulb (DB) and 43°F wet bulb (WB).

¹Power Input is rated at high speed.

²All power wiring / communication cables from ODU to IDU are field supplied and are to be minimum four-conductor, 14 AWG, stranded, shielded or unshielded (if shielded, it must be grounded to the chassis of ODU only), and must comply with applicable local and national codes.

³Take appropriate actions at the end of HVAC equipment life to recover, recycle, reclaim or destroy R410A refrigerant according to applicable regulations (40 CFR Part 82, Subpart F) under section 608 of CAA.

⁴Sound pressure levels are tested in an anechoic chamber under ISO Standard 3745 and are the same in both cooling and heating mode. These values can increase due to ambient conditions during operation.

⁵Piping lengths are equivalent.

GENERAL DATA

Convertible Mid-Static Ducted Specifications

Table 6: Convertible Mid-Static Ducted System General Data (continued).

Type	Single-Zone Convertible Mid-Static Ducted	
System (Model) (Indoor Unit / Outdoor Unit)	LH188HV1 (LHN188HV1 / LUU180HV)	LH248HV1 (LHN248HV1 / LUU240HV)
Cooling Capacity (Min / Rated / Max) (Btu/h)	7,400 ~ 18,000 ~ 21,100	9,600 ~ 23,000 ~ 27,000
Cooling Power Input ¹ (kW)	0.55 ~ 1.43 ~ 2.00	0.72 ~ 1.95 ~ 2.73
EER ₂ @95°F	12.60	11.80
SEER ₂	17.80	18.50
Heating Capacity (Min / Rated / Max) (Btu/h)	6,800 ~ 20,000 ~ 21,800	10,800 ~ 27,000 ~ 30,000
Heating Power Input ¹ (kW)	0.52 ~ 1.62 ~ 2.10	0.58 ~ 2.10 ~ 3.10
COP @47°F	3.62	3.77
HSPF ₂	9.90	10.40
ENERGY STAR 6.1 / Cold Climate	Yes / Yes	Yes / Yes
Power Supply V, Ø, Hz ²	208-230 / 1 / 60	
Power Wiring / Communications Cable (No. x AWG) ²	4 x 14	
Rated Low Heating Capacity (Btu/h)		
Outdoor 17°F (WB) / Indoor 70°F (DB)	12,400	17,500
Low COP @17°F	2.67	2.64
Maximum Heating Capacity (Btu/h)		
Outdoor 17°F (DB) / Indoor 70°F (DB)	21,300	27,800
Outdoor 5°F (DB) / Indoor 70°F (DB)	16,000	24,000
Outdoor -4°F (DB) / Indoor 70°F (DB)	12,340	21,010
Outdoor Unit Operating Range		
Cooling (°F DB)	5 to 118	
Optional Wind Baffle Cooling (°F DB)	Yes (-4) ⁵	
Heating (°F WB)	-4 to 64	
Indoor Unit Operating Range		
Cooling (°F WB)	57 to 77	
Heating (°F DB)	59 to 81	
Indoor Temperature Setting Range		
Cooling (°F)	65 to 86	
Heating (°F)	61 to 86	
Unit Data		
Refrigerant Type ³	R410A	
Refrigerant Control	EEV	
Indoor Unit Sound Pressure Level ±1 dB(A) (H/M/L) ⁴	36 / 32 / 29	38 / 33 / 30
Outdoor Unit Sound Pressure Level ±1 dB(A) (Cool/Heat) ⁴	48 / 52	48 / 52
Indoor Unit Net / Shipping Weight (lbs.)	61.5 / 71.7	64.2 / 74.3
Outdoor Unit Net / Shipping Weight (lbs.)	130.1 / 147.7	130.1 / 147.7
Vertical Installation Kit Net / Shipping Weight (lbs.)	4.41 / 5.95	4.41 / 5.95
Compressor (Type x Qty.)	Twin Rotary x 1	Twin Rotary x 1
Dehumidification Rate (pts./hr.)	2.75	4.23
Fan		
Indoor Unit Type x Qty.	Sirocco x 1	Sirocco x 1
Outdoor Unit Type x Qty.	Propeller x 1	Propeller x 1
Motor / Drive	Brushless Digitally Controlled / Direct	
Airflow Rate		
Indoor Unit (Max. / H / M / L [CFM])	635.7/529.7/423.8	706.3/547.4/459.1
Outdoor Unit (Max. CFM)	2,048	2,048
IDU Factory Set (High) External Static Pressure (in. wg)	0.24	
ODU Factory Set (High) External Static Pressure (in. wg)	0.1	
Piping		
Liquid (in.) (Connection size / Pipe size)	1/4 / 3/8	3/8 / 3/8
Vapor (in.) (Connection size / Pipe size)	1/2 / 5/8	5/8 / 5/8
Indoor Unit Condensate Drain O.D. / I.D. (in.)	1-1/4 / 31/32	
Additional Refrigerant Charge (oz./ft.)	0.43	
Pipe Length (Minimum/Maximum, ft.) ⁵	16.4 / 164	16.4 / 164
Piping Length (no additional refrigerant, ft.) ⁵	24.9	
Maximum Elevation Difference (ft.)	98.4	

EEV: Electronic Expansion Valve, IDU: Indoor Unit, ODU: Outdoor Unit. This unit comes with a dry helium charge.

This data is rated 0 ft above sea level, with 24.6 ft of refrigerant line per indoor unit and a 0 ft level difference between outdoor and indoor units.

Cooling capacity rating obtained with air entering the indoor coil at 80°F dry bulb (DB) and 67°F wet bulb (WB); and outdoor ambient conditions of 95°F dry bulb (DB) and 75°F wet bulb (WB). Heating capacity rating obtained with air entering the indoor unit at 70°F dry bulb (DB) and 60°F wet bulb (WB); and outdoor ambient conditions of 47°F dry bulb (DB) and 43°F wet bulb (WB).

¹Power Input is rated at high speed.

²All power wiring / communication cables from ODU to IDU are field supplied and are to be minimum four-conductor, 14 AWG, stranded, shielded or unshielded (if shielded, it must be grounded to the chassis of ODU only), and must comply with applicable local and national codes.

³Take appropriate actions at the end of HVAC equipment life to recover, recycle, reclaim or destroy R410A refrigerant according to applicable regulations (40 CFR Part 82, Subpart F) under section 608 of CAA.

⁴Sound pressure levels are tested in an anechoic chamber under ISO Standard 3745 and are the same in both cooling and heating mode. These values can increase due to ambient conditions during operation.

⁵Piping lengths are equivalent.



GENERAL DATA

Electrical

Table 7: Electrical Data.

Nominal Tons	Unit Model No.	Hertz	Voltage	Voltage Range (Min. to Max.)	MCA	MOP	Compressor Quantity	Compressor Motor RLA (Cooling)	Condenser Fan Motor(s)	
									Condenser Fan Quantity	Condenser Fan Motor FLA
Mid Static										
3/4	LUU090HV	60	208 - 230	187 - 253	11.9	15	1	9.0	1	0.25
1	LUU120HV				12.3	15		9.0		0.25
1-1/2	LUU180HV				20	30		13.5		1.6
2	LUU240HV				20	30		13.5		1.6

Voltage tolerance is ±10%.

Maximum allowable voltage unbalance is 2%.

RLA = Rated Load Amps.

MCA = Minimum Circuit Ampacity.

Maximum Overcurrent Protection (MOP) is calculated as follows:
 (Largest motor FLA x 2.25) + (Sum of other motor FLA) rounded down to the nearest standard fuse size.

GENERAL INSTALLATION GUIDELINES

Outdoor Unit Location Selection

Selecting the Best Location for the Outdoor Unit

⚠ DANGER

- ⓧ Do not install the unit in an area where combustible gas will generate, flow, stagnate, or leak. These conditions can cause a fire, resulting in bodily injury or death.
- ⓧ Do not install the unit in a location where acidic solution and spray (sulfur) are often used as it can cause bodily injury or death.
- ⓧ Do not use the unit in environments where oil, steam, or sulfuric gas are present as it can cause bodily injury or death.

⚠ WARNING

When deciding on a location to place the outdoor unit, be sure to choose an area where run-off from defrost will not accumulate and freeze on sidewalks or driveways, which will create unsafe conditions. Properly install and insulate any drain hoses to prevent the hose from freezing, cracking, leaking, and causing unsafe conditions from frozen condensate.

⚠ WARNING

Install a fence to prevent vermin from crawling into the unit or unauthorized individuals from accessing it. Vermin and unauthorized individuals will cause a fire, electric shock, physical injury or death. Follow the placement guidelines set forth in "Clearance Requirements".

⚠ NOTE

Install a fence to prevent vermin from crawling into the unit or unauthorized individuals from accessing it. Vermin and unauthorized individuals will damage the unit. Follow the placement guidelines set forth in "Clearance Requirements".

Select a location for installing the outdoor unit that will meet the following conditions:

- Where there is enough strength to bear the weight of the unit.
- A location that allows for optimum air flow and is easily accessible for inspection, maintenance, and service.
- Where piping between the outdoor unit and indoor unit is within allowable limits.
- Include space for drainage to ensure condensate flows properly out of the unit when it is in heating mode. ⓧ Avoid placing the outdoor unit in a low-lying area where water could accumulate.
- If the outdoor unit is installed in a highly humid environment (near an ocean, lake, etc.), ensure that the site is well-ventilated and has a lot of natural light (Example: Install on a rooftop).

ⓧ Do Not's

- Where it will be subjected to direct thermal radiation from other heat sources, or an area that would expose the outdoor unit to heat or steam like discharge from boiler stacks, chimneys, steam relief ports, other air conditioning units, kitchen vents, plumbing vents, and other sources of extreme temperatures.
- Where high-frequency electrical noise / electromagnetic waves will affect operation.
- Where operating sound from the unit will disturb inhabitants of surrounding buildings.
- Where the unit will be exposed to direct, strong winds.
- Where the discharge of one outdoor unit will blow into the inlet side of an adjacent unit (when installing multiple outdoor units).

Planning for Snow and Ice

To ensure the outdoor unit operates properly, certain measures are required in locations where there is a possibility of heavy snowfall or severe windchill or cold:

1. Prepare for severe winter wind chills and heavy snowfall, even in areas of the country where these are unusual phenomena.
2. Position the outdoor unit so that its airflow fans are not buried by direct, heavy snowfall. If snow piles up and blocks the airflow, the system will malfunction.
3. Remove any snow that has accumulated four (4) inches or more on the top of the outdoor unit.
4. In climates that will experience significant snow buildup, mount the outdoor unit on a raised, field-provided platform or stand. The raised support platform must be high enough to allow the unit to remain above possible snow drifts, and must be higher than the maximum anticipated snowfall for the location.
5. Design the mounting base to prevent snow accumulation on the platform in front or back of the unit frame.
6. Provide a field fabricated snow protection hood to keep snow and ice and/or drifting snow from accumulating on the coil surfaces.
7. To prevent snow and heavy rain from entering the outdoor unit, install the condenser air inlets and outlets facing away from direct winds.
8. Consider tie-down requirements in case of high winds or where required by local codes.

GENERAL INSTALLATION GUIDELINES

Outdoor Unit Location Selection

Planning for Snow and Ice, continued.

⚠ CAUTION

When deciding on a location to place the outdoor unit, be sure to choose an area where run-off from defrost cycle will not accumulate and freeze on sidewalks or driveways, which will create unsafe conditions. Properly install and insulate any drain hoses to prevent the hose from freezing, cracking, leaking, and causing unsafe conditions from frozen condensate.

⚠ NOTE

Choose an area where run-off water from defrost cycle will not accumulate and freeze on sidewalks or driveways. Properly install and insulate any drain hoses to prevent the hose from freezing, cracking, leaking, and damaging the outdoor unit.

Note:

The indoor unit will take longer to provide heat, or heating performance will be reduced in winter if the unit is installed:

1. In a narrow, shady location.
2. Near a location that has a lot of ground moisture.
3. In a highly humid environment.
4. In an area in which condensate does not drain properly.

Tie-Downs and Lightning Protection

Tie-Downs

- The strength of the roof must be checked before installing the outdoor units.
- If the installation site is prone to high winds or earthquakes, when installing on the wall or roof, securely anchor the mounting base using a field-provided tie-down configuration approved by a local professional engineer.
- The overall tie-down configuration must be approved by a local professional engineer.

Note:

Always refer to local code when using a wind restraint system.

Lightning Protection

- To protect the outdoor unit from lightning, it must be placed within the specified lightning safety zone.

Table 8: Safety Zone Specifications.

Building Height (feet)	66	98	148	197
Protection Angle (°)	55	45	35	25

- Power cable and communication cable must be installed five (5) feet away from lightning rod.
- A high-resistance ground system must be included to protect against induced lightning or indirect strike.

⚠ NOTE

If the building does not include lightning protection, the outdoor unit will be damaged from a lightning strike. Inform the customer of this possibility in advance.

Figure 3: Lightning Protection Diagram.

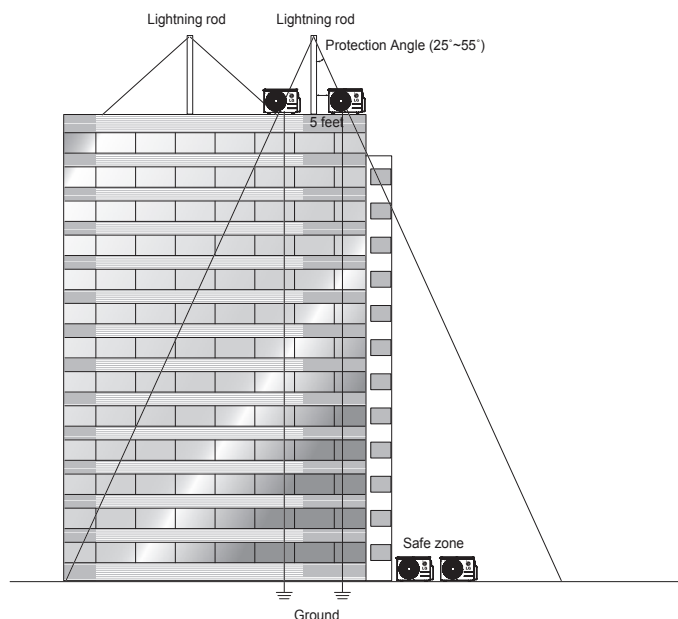

GENERAL INSTALLATION GUIDELINES

Outdoor Unit Location Selection

Oceanside Applications

Use of a Windbreak to Shield from Sea Wind

Note:

Ocean winds will cause corrosion, particularly on the condenser and evaporator fins, which, in turn could cause product malfunction or inefficient performance.

- ⚠️ Avoid installing the outdoor unit where it would be directly exposed to ocean winds.
- Install the outdoor unit on the side of the building opposite from direct ocean winds.
- Select a location with good drainage.
- Periodically clean dust or salt particles off of the heat exchanger with water.

If the outdoor unit must be placed in a location where it would be subjected to direct ocean winds, install a concrete windbreaker strong enough to block any winds. Windbreaker height and width must be more than 150% of the outdoor unit, and be installed at least 27-1/2 inches away from the outdoor unit to allow for airflow.

Note:

Additional anti-corrosion treatment will need to be applied to the outdoor unit at oceanside locations.

Use of a Building to Shield from Sea Wind

If a windbreak is not possible, a building or larger structure must be used to shield the outdoor unit from direct exposure to the sea wind. The unit must be placed on the side of the building directly opposite to the direction of the wind as shown in the figure at right.

Figure 4: Oceanside Placement Using Windbreak.

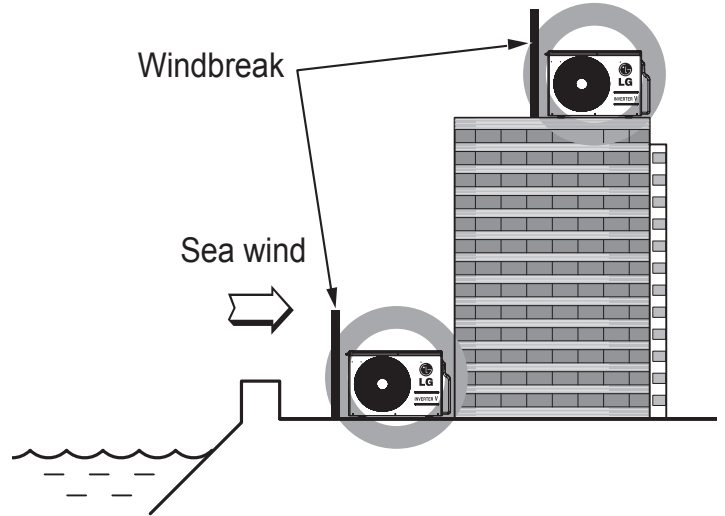
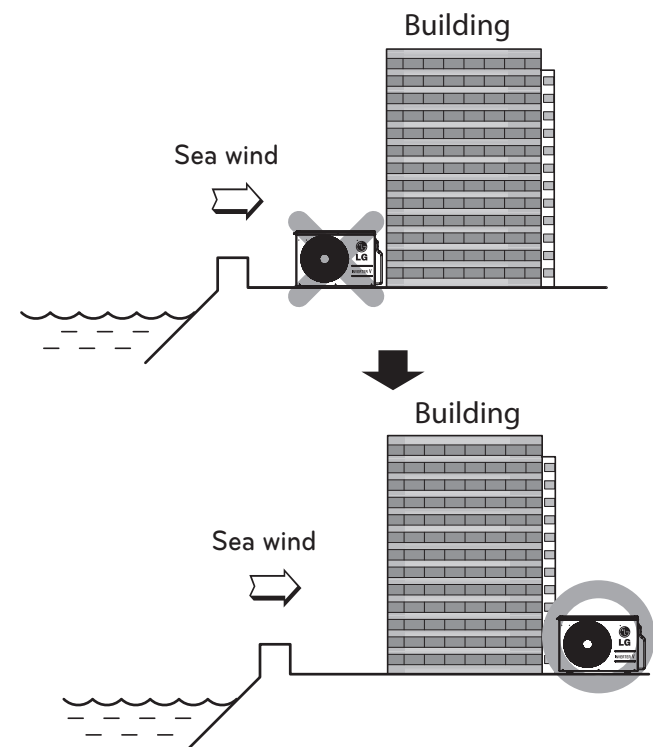

Figure 5: Placement Using Building as Shield.



GENERAL INSTALLATION GUIDELINES

Required Outdoor Unit Clearances

Minimum Allowable Clearance and Service Access Requirements

Proper clearance for the outdoor unit coil is critical for proper unit operation. When installing the outdoor unit, consider service, inlet and outlet, and minimum allowable space requirements as illustrated in the diagrams below and on the following pages.

- Include enough space for airflow and for service access. If installing multiple outdoor units, ⚠ avoid placing the units where the discharge of one unit will blow into the inlet side of an adjacent unit.
- If an awning is built over the unit to prevent direct sunlight or rain exposure, make sure that the discharge air of the outdoor unit isn't restricted.
- ⚠ No obstacles to air circulation around the unit; keep proper distances from ceilings, fences, floor, walls, etc. (Install a fence to prevent pests from damaging the unit or unauthorized individuals from accessing it.)

Outdoor Unit (9,000 to 24,000 Capacity) Service Access and Allowable Clearances

Specific clearance requirements in the diagram below are for (9,000 to 24,000 Btu/h capacities). The figure below shows the overall minimum clearances that must be observed for safe operation and adequate airflow around the outdoor unit.

When placing the outdoor unit under an overhang, awning, sunroof or other "roof-like structure", observe the clearance requirements (as shown in Cases 1 and 2) for height in relation to the unit. To have successful service access to the outdoor unit, see the figure below for minimum spacing. When installing multiple outdoor units, see Cases 4 and 5 for correct spacing requirements.

Note:

If the outdoor unit is installed between standard and minimum clearances, capacity decreases approximately 10%.

Figure 6: 9,000 to 24,000 Capacity Outdoor Unit Service Access and Allowable Clearances Diagram.

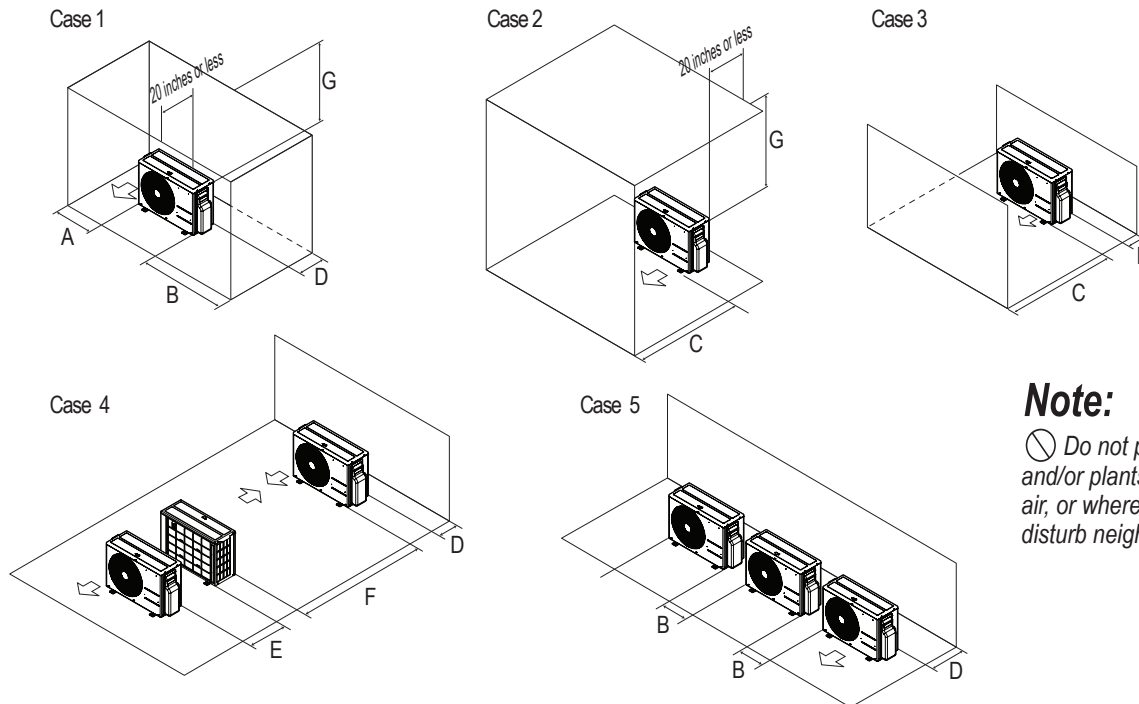

Note:

⚠ Do not place the unit where animals and/or plants will be in the path of the warm air, or where the warm air and/or noise will disturb neighbors.

Table 9: 9,000 to 24,000 Outdoor Unit Service Access and Allowable Clearances Diagram Legend.

Unit: Inch		A	B	C	D	E	F	G
Case 1	Standard	12	24	-	12	-	-	-
	Minimum	4	10	-	4	-	-	40
Case 2	Standard	-	-	20	-	-	-	-
	Minimum	-	-	14	-	-	-	40
Case 3	Standard	-	-	20	12	-	-	-
	Minimum	-	-	14	4	-	-	-
Case 4	Standard	-	-	-	12	24	-	-
	Minimum	-	-	-	4	8	79	-
Case 5	Standard	-	24	-	12	-	-	-
	Minimum	-	10	-	4	-	-	-

GENERAL INSTALLATION GUIDELINES

Rigging and Lifting / Outdoor Unit Mounting

Rigging and Lifting Instructions

⚠ WARNING

Wear protective gloves and safety goggles when handling equipment. Sharp edges will cause personal injury.

Dispose of the packing materials safely.

- Packing materials, such as nails and other metal or wooden parts, will cause puncture wounds or other injuries.
- Remove the wood pallet from the bottom of the outdoor unit drain pan before installing it to the platform / bracket / etc. An unstable installation will cause the outdoor unit to fall, resulting in physical injury and / or death. Also, brazing around a wood pallet will result in a fire, causing physical injury and / or death.
- Tear apart and throw away plastic packaging bags so that children do not play with them and risk suffocation and death.

⚠ CAUTION

- Be very careful when transporting the product. There is a risk of the product falling and causing physical injury.
- Use appropriate moving equipment to transport each frame; ensure the equipment is capable of supporting the weights listed.
- Some products use polypropylene bands for packaging. Ⓞ Do not use polypropylene bands to lift the unit.
- Support the outdoor unit at a minimum of four points to avoid slippage from rigging apparatus.

⚠ NOTE

- Make sure the outdoor unit is in its original packaging to avoid damage during local transport.
- At the time of delivery, the package must be checked for any damage (exterior and interior). Report any damage to the carrier claims agent immediately.
- Handle the outdoor unit with care. Keep the outdoor unit upright to avoid damaging inside components.
- If a forklift is to transport the outdoor unit, the forklift arms must pass through the openings at the bottom.
- If a crane is to suspend the outdoor unit, it is required that two (2) ropes at least twenty-three (23) feet in length be used. Pass the ropes under the unit. Pass the rope through the two (2) forklift slots each at the front and rear of the outdoor unit.
- To prevent damage to the outdoor unit, always lift the unit with the ropes attached at four (4) points at an angle of $\leq 40^\circ$.
- Always include padding to protect the outdoor unit from rope damage, and take into consideration the outdoor unit's center of gravity.
- Remove the wood pallet from the bottom of the outdoor unit drain pan before installing it to the platform / bracket / etc. Improper installation with the wood pallets still on the outdoor unit will cause the heat exchanger to freeze, resulting in operation malfunction.

General Outdoor Unit Mounting

Any underlying structure or foundation must be designed to support the weight of the outdoor unit. Ⓞ Avoid placing the unit in a low lying area where water and ice will accumulate. Securely attach the outdoor unit to a condenser pad, base rails, or a mounting platform that is solidly anchored to the ground or building structure. When installing the outdoor unit on the wall or roof top, securely anchor the mounting base to account for wind, earthquakes, or vibration.

Anchoring the Outdoor Unit

- Tightly anchor the outdoor unit with a bolt and nut to a concrete or rigid platform (see next page for more details).
- When installing on a wall (with field-supplied brackets), roof, or rooftop, securely anchor the mounting platform with nails, taking into consideration the possibility of strong winds or earthquakes.
- If there is a possibility of vibration from the outdoor unit transmitting to the building, add an anti-vibration material.

Note:

Follow applicable local codes for clearance, mounting, anchor and vibration attenuation requirements.

Outdoor Unit Platform Concrete Specifications

- Concrete foundations must be made of one part cement, two parts sand, and four parts gravel.
- The surface of the foundation must be finished with mortar with rounded edges, and weatherproofed.
- See table and figures on the next page for height, width, etc., requirements.
- Include an area for drainage around the foundation to ensure condensate thoroughly drains away from the outdoor unit.

Figure 7: Examples of Outdoor Unit Mounting Methods.

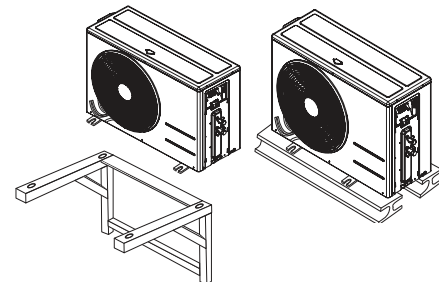

GENERAL INSTALLATION GUIDELINES

Outdoor Unit Mounting

Outdoor Unit Platform Dimensional Requirements

Note:

- All referenced materials are to be field supplied. Images are not to scale.
- Review the specifications for field-supplied pad mounts or brackets to verify that outdoor dimension requirements are met.

Figure 8: Bolting the LUU090HV, LUU120HV Outdoor Units to the Platform (Appearance May Vary).

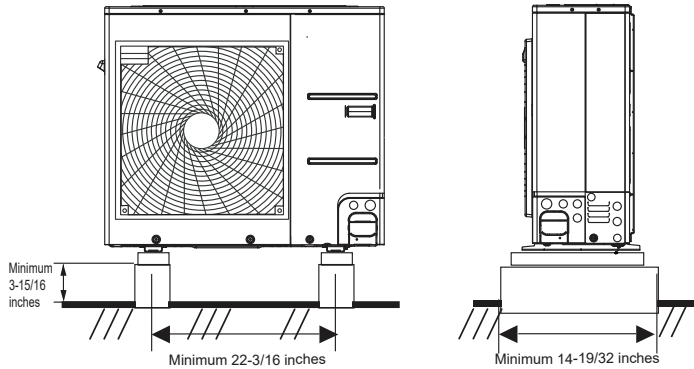
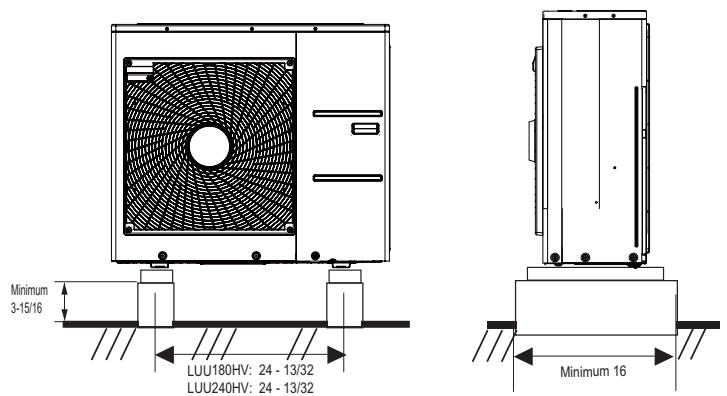

Figure 9: Bolting the LUU180HV, LUU240HV Outdoor Units to the Platform (Appearance May Vary).



Bolting the Outdoor Unit to the Platform

1. Ensure that the concrete platform will not degrade easily, and has enough structural strength to bear the weight of the unit.
2. Include an H-beam support. Firmly attach the corners, otherwise the support will bend.
3. Use a hexagon nut.
4. Use anti-vibration material.
5. If there is a possibility of vibration from the outdoor unit transmitting to the building, add an anti-vibration material to the platform.
6. Seal all wiring and piping access holes with field-supplied sealing material to prevent animals and bugs from entering the unit.

Table 10: Outdoor Unit Foundation Specifications.

Outdoor Unit	Bolt Type	Concrete Height	Bolt Depth
LUU090HV	M10-J	Minimum 3-15/16 inches	Minimum 2-3/8 inches
LUU120HV			
LUU180HV			
LUU240HV			

Figure 10: Example of Using an Insert for a Hole in a Reinforced Concrete Beam.

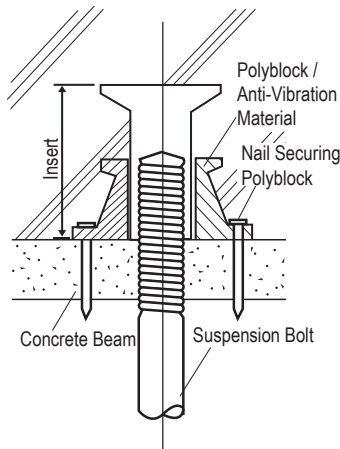

Figure 11: Close up of a Bolt Attachment.

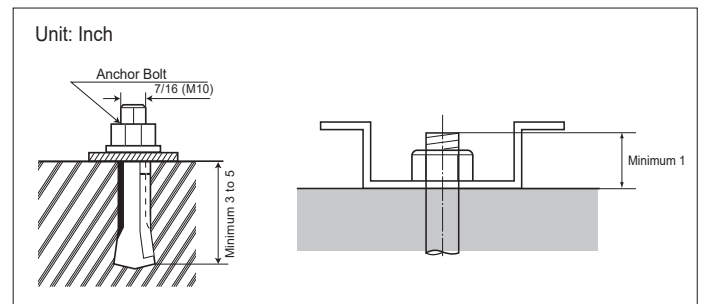
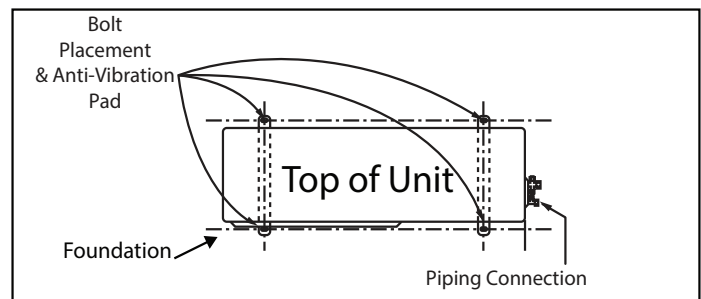

Figure 12: Bolting the Outdoor Unit to the Platform (Piping Location Will Differ Depending on Outdoor Unit Model).



GENERAL INSTALLATION GUIDELINES

Indoor Unit Location Selection / Required Indoor Unit Clearances

Selecting the Best Location for the Indoor Unit

⚠ DANGER

To avoid the possibility of fire, ⚡ do not install the unit in an area where combustible gas will generate, flow, stagnate, or leak. Failure to do so will cause serious bodily injury or death. Before beginning installation, read the safety summary at the beginning of this manual.

Note:

Follow recommended best practices when choosing an indoor location for the single zone indoor unit.

Dos

Select a location for installing the indoor units that will meet the following conditions:

- Place the unit where air circulation will not be blocked.
- Locate the indoor unit in a location that is level, with enough strength to bear the weight of the indoor unit(s), and where it can be easily connected to the outdoor unit.
- Place the unit where drainage can be obtained easily and to minimize the length of the condensate drain piping; include space for drainage to ensure condensate flows properly out of the unit when it is in cooling mode.
- Include enough space around the indoor unit so that it is accessible for maintenance and service purposes. Include enough space to be able to clean the filter.
- Where electrical noise / electromagnetic waves will not affect indoor unit operation. Maintain proper distances between the indoor units and electric wires, audio and visual appliances, breaker / circuit panels, etc. If the frequency signal of the appliance is unstable, then install the indoor unit a minimum of ten (10) feet away, and run the power and transmission cables through a conduit.
- Place the unit where operating sound from the unit will not disturb occupants.
- Confirm that there is enough space for and between the indoor unit and the suspension bolts.

⚡ Dont's

- Do not install the unit near a heat or steam source, or where considerable amounts of oil, iron powder, or flour are used. (These materials may generate condensate, cause a reduction in heat exchanger efficiency, or the drain to malfunction. If this is a potential problem, install a ventilation fan large enough to vent out these materials.)
- The unit should not be installed in an area where sulfuric acid and flammable or corrosive gases are generated, flowed, vented into, stagnate, leak, or stored.
- The unit should not be installed in a location where acidic solution and spray (sulfur) are often used.
- Ensure there are no obstacles to air circulation around the unit; keep proper distances from ceilings, doorways, floor, walls, etc.
- Avoid installing the unit near high-frequency generators or near any equipment that generates an electromagnetic field (minimum 3-1/3 feet away).

⚠ WARNING

The unit must not be installed where sulfuric acid and flammable or corrosive gases are generated, vented into, or stored. There is risk of fire, explosion, and physical injury or death.

The unit may be damaged, may malfunction, and / or will not operate as designed if installed in any of the conditions listed.

⚠ NOTE

- ⚡ Indoor units (IDUs) must not be placed in an environment where the IDUs may be exposed to harmful volatile organic compounds (VOCs) or in environments where there is improper air make up or supply or inadequate ventilation. If there are concerns about VOCs in the environment where the IDUs are installed, proper air make up or supply and/ or adequate ventilation must be provided. Additionally, in buildings where IDUs will be exposed to VOCs consider a factory-applied epoxy coating to the fan coils for each IDU.
- If the unit is installed near a body of water, the installation parts are at risk of corroding. Appropriate anti-corrosion methods must be taken for the unit and all installation parts.

Figure 13: Installing Near a Heat or Steam Source.

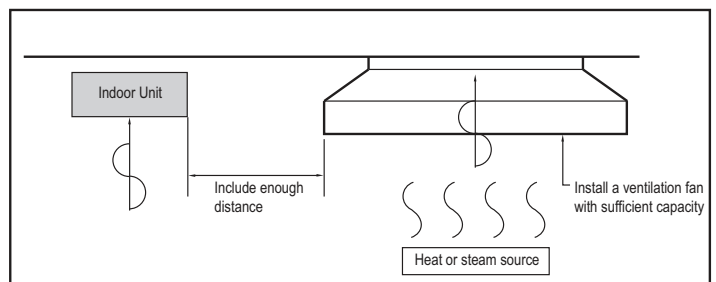

GENERAL INSTALLATION GUIDELINES

Indoor Unit Bolt Locations

NOTE

Ensure the ductwork and its material follows local, state, and federal codes for supplying / circulating air.

There is risk of product failure and / or damage.

Installing in an Area Exposed to Unconditioned Air

In some installation applications, areas (floors, walls) in some rooms may be exposed to unconditioned air (room may be above or next to an unheated garage or storeroom). To countermeasure:

- Verify that carpet is or will be installed (carpet may increase the temperature by three [3] degrees).
- Add insulation between the floor joists.
- Install radiant heat or another type of heating system to the floor.

Installing in an Area with High Humidity Levels

If the environment is prone to humidity levels of 80% or more (near the ocean, lakes, etc.) or where steam could collect in the plenum:

- Install additional insulation to the indoor unit (glass wool insulation >13/32 inches thick).
- Install additional insulation to the refrigerant piping (insulation >13/16 inches thick).
- Seal all gaps between the indoor unit and the ceiling tiles (make the area air tight) so that humidity does not transfer from the plenum to the conditioned space. Also, add a ceiling grille for ventilation.

Mid-Static Ducted IDU Bolt Locations

Figure 14: Mid Static Ducted Indoor Unit Bolt Locations.

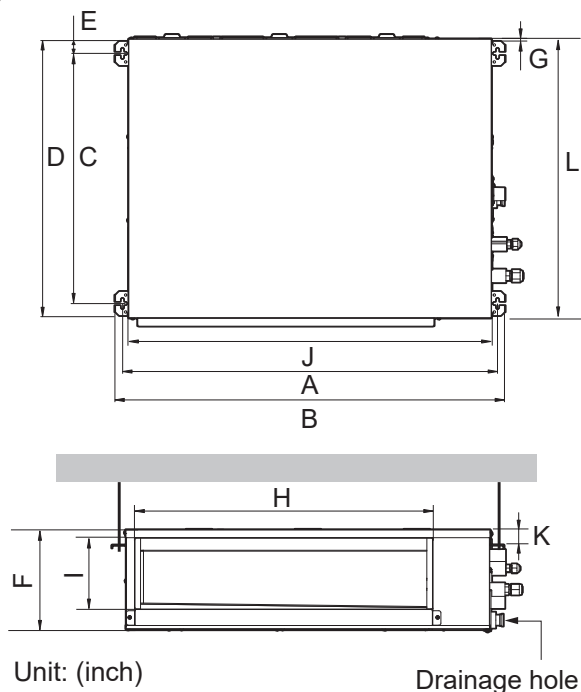

Table 11: Mid Static Ducted Indoor Unit Bolt Location Dimensions.

Model / Capacity (Btu/h)	Dimensions (inches)											
	A	B	C	D	E	F	G	H	I	J	K	L
LHN098HV1 / 9,000	36-3/4	38-9/32	24-3/8	26-3/4	1-3/16	9-21/32	7/32	29-1/16	6-15/16	35-7/16	1-15/32	27-9/16
LHN128HV1 / 12,000	36-3/4	38-9/32	24-3/8	26-3/4	1-3/16	9-21/32	7/32	29-1/16	6-15/16	35-7/16	1-15/32	27-9/16
LHN188HV1 / 18,000	36-3/4	38-9/32	24-3/8	26-3/4	1-3/16	9-21/32	7/32	29-1/16	6-15/16	35-7/16	1-15/32	27-9/16
LHN248HV1 / 24,000	36-3/4	38-9/32	24-3/8	26-3/4	1-3/16	9-21/32	7/32	29-1/16	6-15/16	35-7/16	1-15/32	27-9/16

GENERAL INSTALLATION GUIDELINES

Required Service Space / Preparing for Horizontal Installation

Mid-Static Ducted IDU Service Space Required Dimensions

Figure 15: Minimum Mid-Static Ducted Indoor Unit Clearance Requirements.

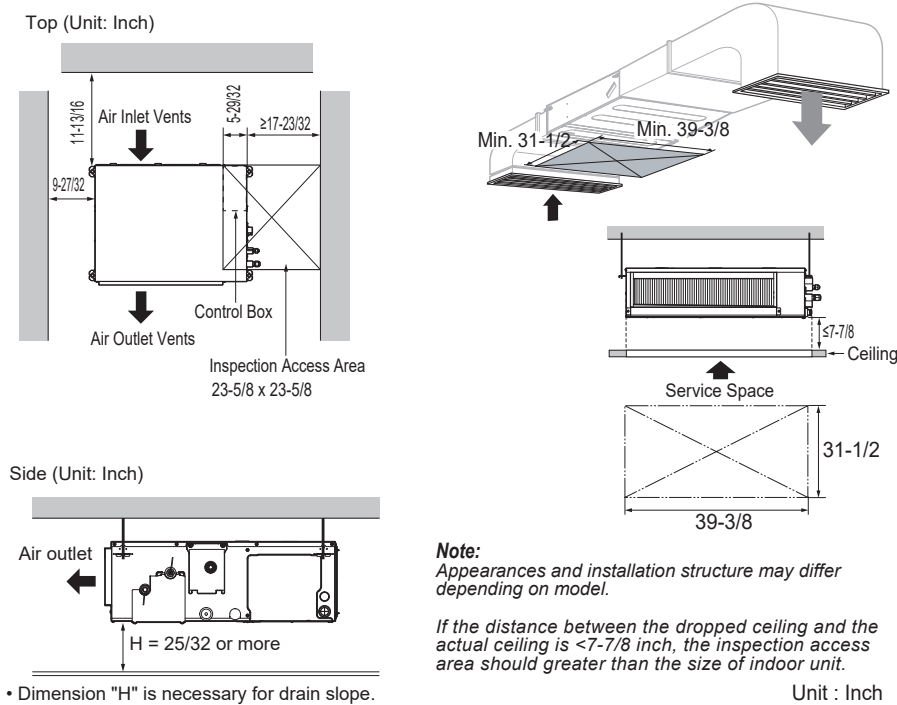

Preparing the Installation Area

1. Choose the location for the indoor unit. Mark where the four (4) hanging / suspension bolts, refrigerant piping, and drain should be. Hanging / suspension bolt angle must account for drain direction.
2. Drill holes for the four (4) hanging / suspension bolts.
3. Apply a joint-canvas between the indoor unit and duct to absorb vibration.
4. Install a filter accessory at the air return.

Figure 16: Drilling the Holes.

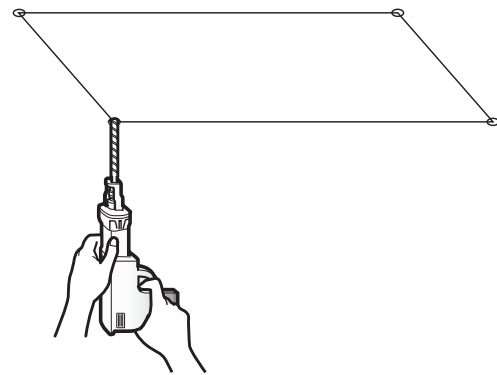

⚠ WARNING

- The threaded rod hangars (bolts) and hardware must be securely installed to prevent the frame falling from its location. There is risk of injury from falling equipment.
- Installation work must be performed by trained personnel and in accordance with all local or other applicable codes. There is risk of personnel injury from incorrect installation.
- During installation, ⚡ do not damage the cable / wiring. There is a risk of electrical shock, fire, physical injury and / or death.

⚠ NOTE

- The threaded rod hangars (bolts) and hardware must be securely installed to prevent the frame falling from its location. There is risk of property damage from falling equipment.
- Ensure the unit is properly installed. Incorrectly installed units can result in degraded performance or an inoperative unit/system.
- Ensure the frame is installed on a level plane. Incorrectly installed units can result in degraded performance or an inoperative unit/system.

GENERAL INSTALLATION GUIDELINES

Hanging the Indoor Unit for Horizontal Installation

Hanging the Indoor Unit

The following parts are field supplied:

- Anchor
- Hanging bolt - W-3/8" or M10
- Nut - W-3/8" or M10
- Spring washer - M10

The following parts are included with the indoor unit:

- Flat washer - M10

Figure 17: Installing the Hanging Bolt in the Ceiling.

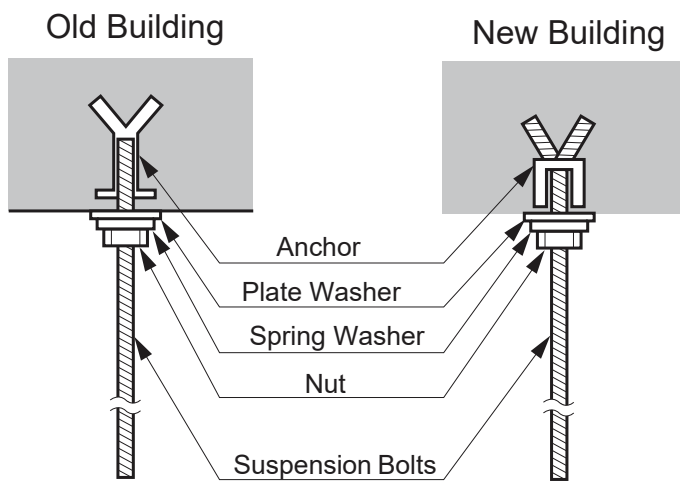
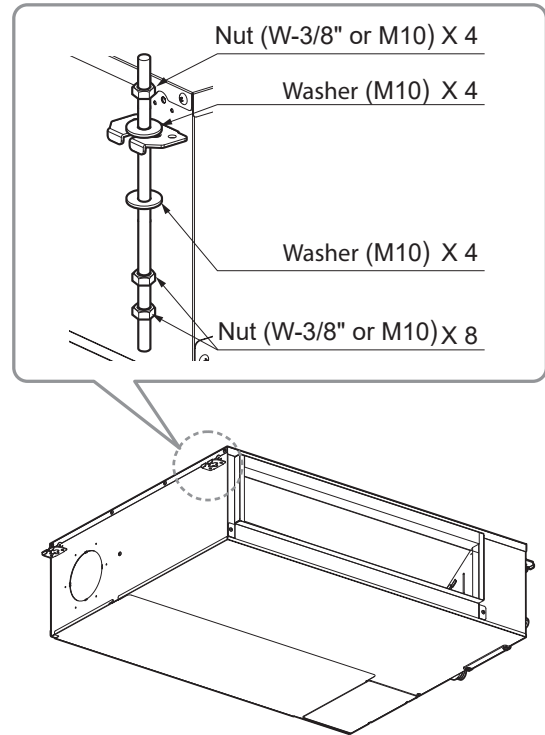

Figure 18: Close Up of Hanging / Suspension Bolt on the Indoor Unit.



For New Ceilings

1. Use a sunken insert, a sunken anchor, or any other field-supplied part to reinforce the ceiling so that it can bear the weight of the indoor unit. Use a temporary washer plate to more easily set up the unit suspension location.
2. Adjust the height of the indoor unit accordingly. Adjust the clearance before hanging the indoor unit.
3. Refer to the indoor unit for the dimensions to the ceiling opening.
4. Remove the temporary washer plate and position the indoor unit hanger brackets on the bolts. Secure with nuts and washers on the top and bottom of the hanger brackets.
5. Mid-static indoor units are equipped with a drain, therefore, the unit must be installed properly or condensate will drip out and cause product malfunction and / or property damage.

For Existing Ceilings

1. Use anchors when installing the indoor unit in an existing ceiling.
2. Adjust the height of the indoor unit accordingly. Adjust the clearance before hanging the indoor unit.
3. Remove the temporary washer plate and position the indoor unit hanger brackets on the bolts. Secure with nuts and washers on the top and bottom of the hanger brackets.
4. Mid-static indoor units are equipped with a drain, therefore, the unit must be installed properly or condensate will drip out and cause product malfunction and / or property damage.

GENERAL INSTALLATION GUIDELINES

Vertical Installation

Vertical Indoor Unit Installation

Option 1. Floor Installation

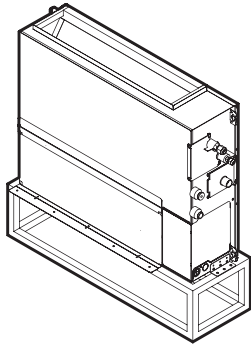

Platform (Field Supplied)

Option 2. Wall Installation

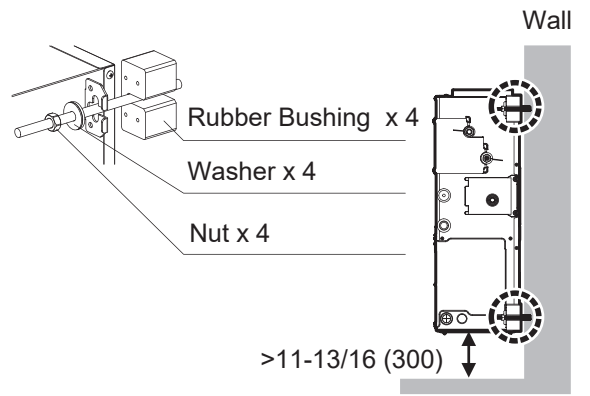
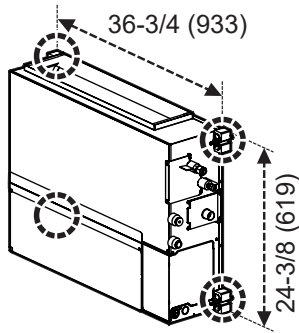

Unit: Inch (mm)

Note:

See also the Vertical Conversion Kit Installation, Vertical Installation Conversion Kit Wiring, and Vertical Condensate Piping pages later in this section.

For Wood Walls



Wood Insert Nuts
Bolts (M10 / L100 Four [4] Each)
(Field Supplied)

For Concrete Walls

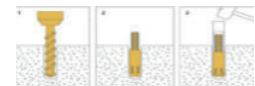

Anchor Bolts
(M10 / L100, Four [4] Each)

GENERAL INSTALLATION GUIDELINES

Installing for Condensate Drainage / Drilling the Piping Hole

Installing for Condensate Drainage

Note:

- It is very important to include a slope for indoor unit installation to ensure proper condensate drainage

Figure 19: Include Slope for Indoor Unit Installation.

Front (Horizontal Installation)

The indoor unit must slope in the direction of the drain hole / piping

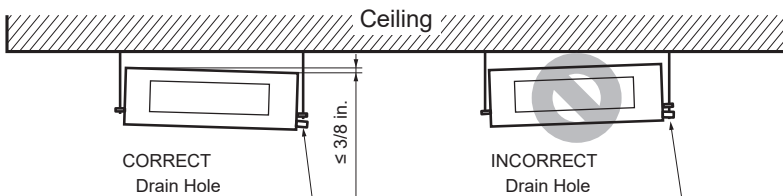

Front (Vertical Installation)

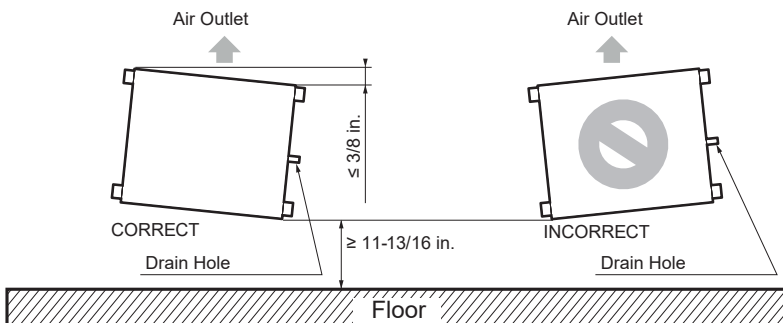

Side (Vertical Installation)

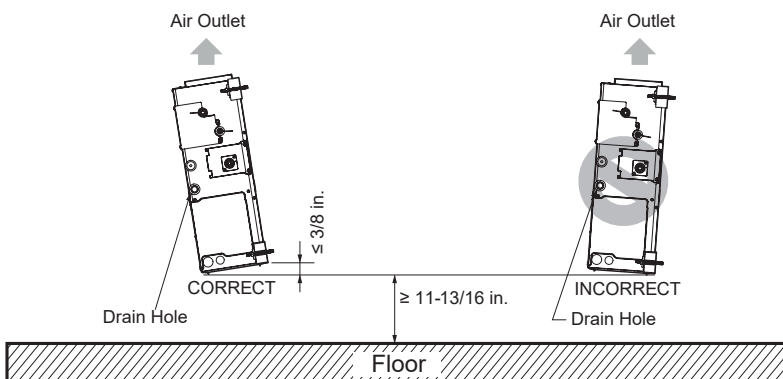

Drilling the Piping Hole

Follow all piping clearance recommendations.

1. Using a 2-5/8 inch hole core drill bit, drill a hole following installation guidelines and application needs. Avoid obstructions in the wall such as electrical wires or conduits and water or gas pipes.
 - The slant of the hole must be 3/16 inches to 5/16 inches from level with the slant being upward on the indoor unit side and downward on the outdoor unit side.
2. Finish off the newly drilled hole as shown with bushing and sleeve covering to prevent damage to the insulation and piping.
 - Sleeve and bushing prevents piping / bundling damage.

Note:

- See *Refrigerant Piping Connections for Indoor Unit* for information on piping installation.
- See the *Refrigerant Piping Connections* section of this manual for information on indoor unit piping connection installation.
- See the *Electrical Connections* section of this manual for information on conduit / electrical wiring to the indoor unit.

Figure 20: Drilling the Piping Hole.

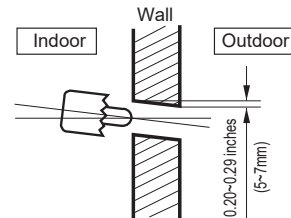

Drill the piping access hole slightly tilted to the outdoor side using a Ø2-5/8 inch hole-core drill.

GENERAL INSTALLATION GUIDELINES

Vertical Conversion Kit Installation

Vertical Conversion Kit Installation

The conversion kit is required in vertical mid-static ducted indoor unit applications (see below). Additional electrical work is also required. See the "Electrical System Installation Section" for the conversion kit electrical procedure.

Step 1.

Remove back / bottom panel, control box cover, pipe panel, and front panel.

Figure 21: Vertical Conversion Kit Installation Procedure..

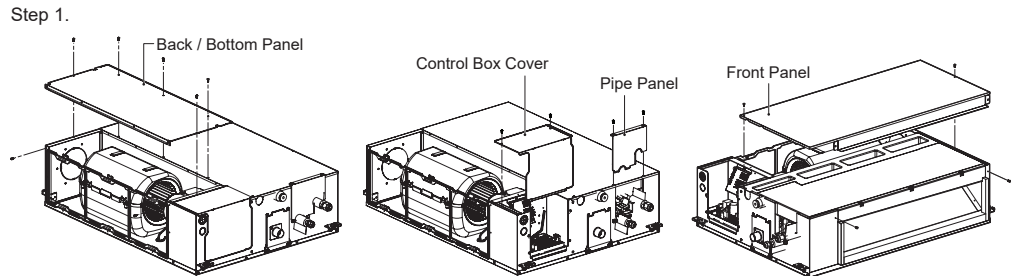

Step 2.

Remove corner packing material and knock-out hole.

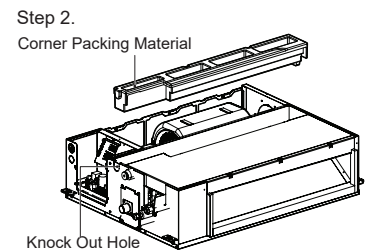

Step 3.

Replace corner packing material with vertical drain pan assembly (factory provided with the conversion kit).

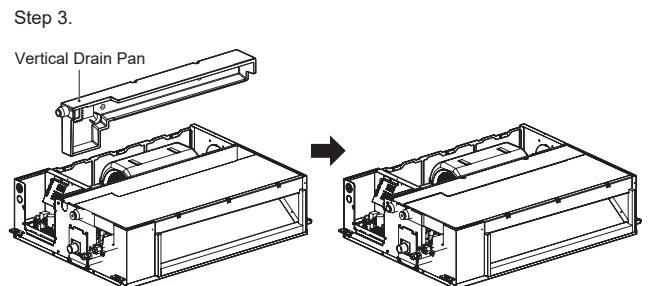

Step 4.

Change the wiring connections for the drain pump (See Mid-Static Ducted Vertical Installation Conversion Kit Wiring).

Step 5.

Install the metal mesh for safety. Remove pre-filter (if present). Attach the metal mesh using four (4) screws and four (4) hooks (Step 5A) (included). Attach pre-filter after metal mesh is secured (Step 5B).

Step 6.

Reassemble in reverse order: reattach the front panel, the pipe panel, the control box cover, and then the back / bottom panel.

Step 7.

Install the mid-static ducted indoor unit in the pre-determined location.

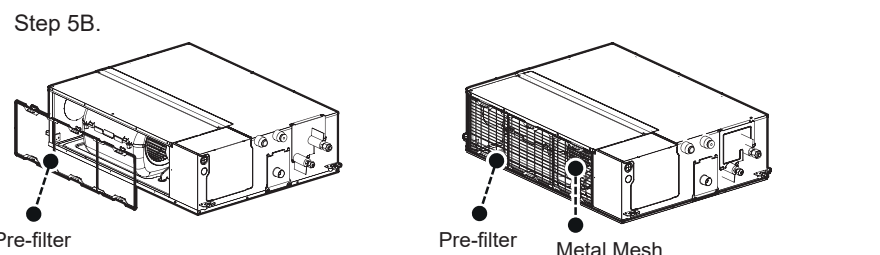
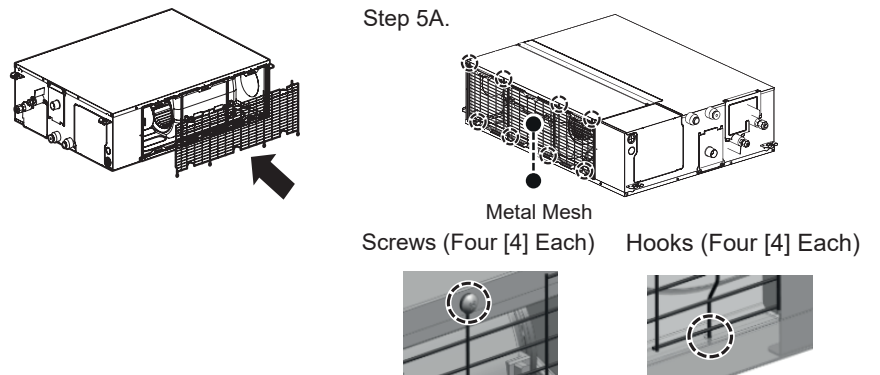

GENERAL INSTALLATION GUIDELINES

Changing the Inlet Position

Changing Inlet from Back to Bottom of Indoor Unit

Note:

Apply based on duct configuration. Example: Change the inlet from back to bottom in applications where the indoor unit is installed in a recessed ceiling, the return grille is under the indoor unit for a bottom return, and the discharge is horizontal into the room.

Step 1.

The mid-static ducted indoor unit is originally configured with the air inlet at the back.

Step 2.

Detach the screws holding the back / bottom panel, and remove the panel. Remove the pre-filter. Place the panel, the screws, and the pre-filter to the side.

Step 3.

Flex the panel: Push in the center to squeeze in back of the indoor unit, and slip the edges in / over the flange. Attach the panel to the flange with the screws. If the hooks on the housing are damaged, use two (2) field-supplied screws to attach the panel using the spare holes (see figure at right).

Step 4.

Re-attach the pre-filter at the flange on the bottom of the indoor unit. The inlet is now re-configured to the bottom of the mid-static ducted indoor unit.

Figure 22: Changing the Inlet Position.
Step 1.

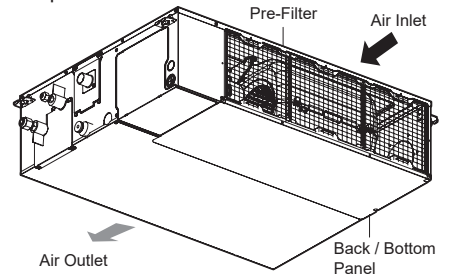

Step 3.

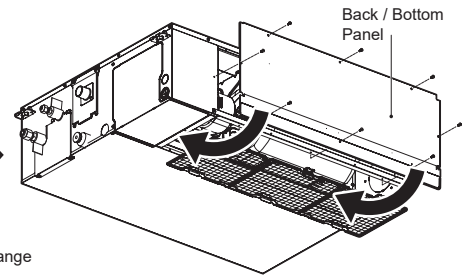

Step 4.

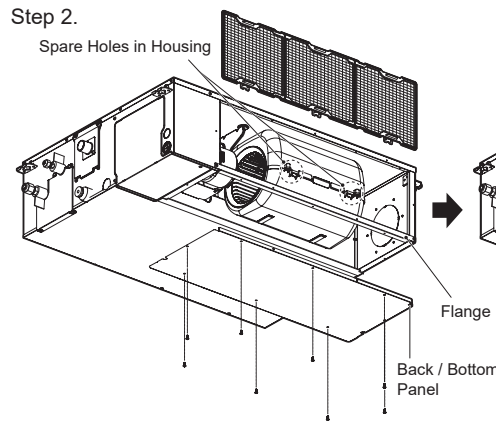
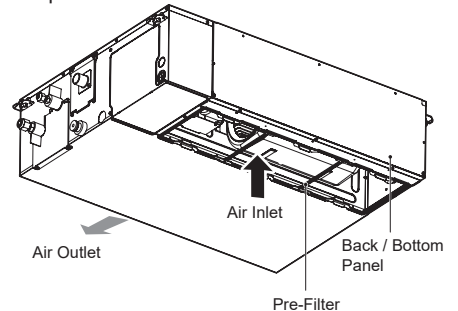

REFRIGERANT SAFETY STANDARDS / DEVICE CONNECTION LIMITATIONS

Refrigerant Safety Standards

ASHRAE Standards 15-2010 and 34-2010 address refrigerant safety and the maximum allowable concentration of refrigerant in an occupied space. Refrigerant will dissipate into the atmosphere, but a certain volume of air is required to safely dissipate the refrigerant. For R410A refrigerant, the maximum allowable concentration of refrigerant is 26 lbs./1,000 cubic feet (Addendum L modified the RCL to 26) of occupied spaces. Buildings with 24-hour occupancy are allowed half of that concentration.

If a single zone system develops a refrigerant leak, the entire refrigerant charge of the system will dump into the area where the leak occurs. To meet ASHRAE Standards 15 and 34, the smallest room volume on the system must be calculated and compared to the maximum allowable concentration. Also consult state and local codes in regards to refrigerant safety.

Device Connection Limitations

A single-zone system consists of one outdoor unit and one indoor unit. One of the most critical elements of a single-zone system is the refrigerant piping. If the connection piping is not within allowable limits, there will be reliability, performance, noise, and vibration issues. The tables below lists pipe length limits that must be followed in the design of a Single Zone Convertible Mid-Static Ducted refrigerant pipe system. Refer to the figures for maximum length and elevation of piping.

Figure 23: Typical LH098HV1 and LH128HV1 System Layout.

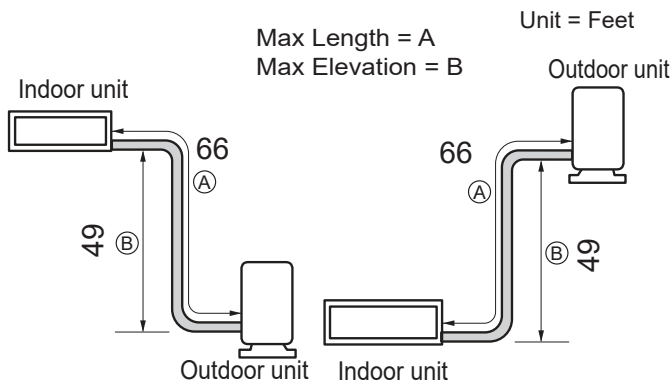

Figure 24: Typical LH188HV1, and LH248HV1 System Layout.

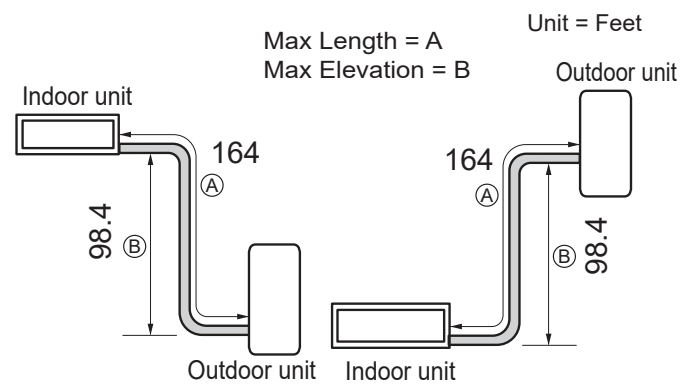

Table 12: Single-Zone Convertible Mid-Static Ducted Refrigerant Piping System Limitations.

System Model Name		LH098HV1	LH128HV1	LH188HV1	LH248HV1
Pipe Length (ELF = Equivalent Length of Pipe)	Longest total equivalent piping length	66 feet	66 feet	164 feet	246 feet
	Shortest total equivalent piping length	16.4	16.4	16.4	16.4
	Distance between fittings and indoor or outdoor units	≥20 inches	≥20 inches	≥20 inches	≥20 inches
	No additional refrigerant	24.9 feet	24.9 feet	24.9 feet	24.9 feet
Elevation (All Elevation Limitations are Measured in Actual Feet)	If outdoor unit is above indoor unit	49 feet	49 feet	98.4 feet	98.4 feet
	If outdoor unit is below indoor unit	49 feet	49 feet	98.4 feet	98.4 feet
Additional Refrigerant Needed (oz/ft)		0.22	0.22	0.43	0.43

SELECTING FIELD SUPPLIED PIPING

Selecting Field-Supplied Copper Piping

Note:

Always follow local codes when selecting and installing copper pipe and piping system components.

Approved piping for use with LG Single Zone products will be marked "R410 RATED" along the length of the pipe. Piping wall thickness must meet local code requirements and be approved for a maximum operating pressure of 551 psi. When bending piping, try to keep the number of bends to a minimum, and use the largest radii possible to reduce the equivalent length of installed piping; also, bending radii greater than ten (10) piping diameters can minimize pressure drop. Be sure no traps or sags are present.

For Single Zone Systems

LG prefers the use of ACR copper piping rated at the system working pressure was used.

Note:

Always properly support the piping as per the instructions on page 35.

Table 13: ACR Rated Copper Tubing Material.

Type	Seamless Phosphorous Deoxidized
Class	UNS C12200 DHP
Straight Lengths	H58 Temper
Coils	O60 Temper

Table 14: Piping Tube Thicknesses.

OD (in)	1/4	3/8	1/2	5/8	3/4	7/8	1-1/8	1-3/8	1-5/8
Material	Rigid or Soft ACR Rated for R410A				Rigid or Soft ACR Rated for R410A				
Min. Bend Radius (in)	0.563	0.9375	1.5	2.25	3.0	3.0	3.5	4.0	4.5
Min. Wall Thickness (in)	0.03	0.03	0.03	0.03	0.03	0.03	0.03	0.04	0.050

Table 15: ACR Copper Tubing Dimensions and Physical Characteristics¹⁻³.

Nominal Pipe Outside Diameter (in)	Actual Outside Diameter (in)	Tempered (Hard Drawn)			Annealed (Soft)		
		Nominal Wall Thickness (in)	Weight (lb/ft)	Cubic ft per Linear ft	Nominal Wall Thickness (in)	Weight (lb/ft)	Cubic ft per Linear ft
1/4	0.250	--	--	--	0.030	0.081	0.00020
3/8	0.375	0.030	0.126	0.00054	0.032	0.134	0.00053
1/2	0.500	0.035	0.198	0.00101	0.032	0.182	0.00103
5/8	0.625	0.040	0.285	0.00162	0.035	0.251	0.00168
3/4	0.750	0.042	0.362	0.00242	0.042	0.362	0.00242
7/8	0.875	0.045	0.455	0.00336	0.045	0.455	0.00336
1-1/8	1.125	0.050	0.655	0.00573	0.050	0.655	0.00573

¹All dimensions provided are in accordance with ASTM B280 – Standard..

²Design pressure = 551 psig.

³The Copper Tube Handbook, 2010, Copper Development Association Inc., 260 Madison Avenue, New York, NY 10016.

Note:

- Commercially available piping often contains dust and other materials. Always blow it clean with a dry inert gas.
- Prevent dust, water or other contaminants from entering the piping during installation.

COPPER EXPANSION AND CONTRACTION

Copper Expansion and Contraction

Under normal operating conditions, the vapor pipe temperature of a Single Zone System can vary as much as 280°F. With this large variance in pipe temperature, the designer must consider pipe expansion and contraction to avoid pipe and fitting fatigue failures.

Refrigerant pipe along with the insulation jacket form a cohesive unit that expands and contracts together. During system operation, thermal heat transfer occurs between the pipe and the surrounding insulation. If the pipe is mounted in free air space, no natural restriction to movement is present if mounting clamps are properly spaced and installed.

The refrigerant pipe support system must be engineered to allow free expansion to occur. When a segment of pipe is mounted between two fixed points, provisions must be provided to allow pipe expansion to naturally occur. The most common method is the inclusion of expansion Loop or U-bends. Each segment of pipe has a natural fixed point where no movement occurs. This fixed point is located at the center point of the segment assuming the entire pipe is insulated in a similar fashion. The natural fixed point of the pipe segment is typically where the expansion Loop or U-bend must be.

Linear pipe expansion can be calculated using the following formula:

$$LE = C \times L \times (T_r - T_a) \times 12$$

LE	=	Anticipated linear tubing expansion (in.)
C	=	Constant (For copper = 9.2×10^{-6} in./in.°F)
L	=	Length of pipe (ft.)
T_r	=	Refrigerant pipe temperature (°F)
T_a	=	Ambient air temperature (°F)
12	=	Inches to feet conversion (12 in./ft.)

1. From the “Linear Thermal Expansion of Copper Tubing in Inches” Table on the next page, find the row corresponding with the actual length of the straight pipe segment.

2. Estimate the minimum and maximum temperature of the pipe. In the column showing the minimum pipe temperature, look up the anticipated expansion distance. Do the same for the maximum pipe temperature.
3. Calculate the difference in the two expansion distance values. The result will be the anticipated change in pipe length.

General Example:

A system is installed and the design shows that there is a 100 foot straight segment of tubing between an indoor unit and the outdoor unit. In heating, this pipe transports hot gas vapor to the indoor units at 120 °F. In cooling, the same tube is a suction line returning refrigerant vapor to the outdoor unit at 40 °F. Look up the copper tubing expansion at each temperature and calculate the difference.

Vapor Line

Transporting Hot Vapor: 100 ft. pipe at 120 °F = 1.40 in.

Transporting Suction Vapor: 100 ft. pipe at 40 °F = 0.40 in.

Anticipated Change in Length: 1.40 in. – 0.40 in. = 1.00 in.

Liquid Line

The liquid temperature remains relatively the same temperature; only the direction of flow will reverse. Therefore, no significant change in length of the liquid line is anticipated.

When creating an expansion joint, the joint height must be a minimum of two times the joint width. Although different types of expansion arrangements are available, the data for correctly sizing an Expansion Loop is provided in the “Radii of Coiled Expansion Loops and Developed Lengths of Expansion Offsets” Table on the next page. Use soft copper with long radius bends on longer runs or long radius elbows for shorter pipe segments. Using the anticipated linear expansion (LE) distance calculated, look up the Expansion Loop or U-bend minimum design dimensions. If other types of expansion joints are chosen, design per ASTM B-88 Standards.

See table on next page for precalculated anticipated expansion for various pipe sizes and lengths of refrigerant tubing.

To find the anticipated expansion value:

1. From the table on the next page, find the row corresponding with the actual feet of the straight pipe segment.
2. Estimate the minimum and maximum temperature of the pipe.
3. In the column showing the minimum pipe temperature, look up the anticipated expansion distance corresponding to the segment length. Do the same for the maximum pipe temperature.
4. Calculate the difference in the two expansion distance values. The result will be the change in pipe length.

COPPER EXPANSION AND CONTRACTION

Table 16: Linear Thermal Expansion of Copper Tubing in Inches.

Pipe Length ¹	Fluid Temperature °F																			
	35°	40°	45°	50°	55°	60°	65°	70°	75°	80°	85°	90°	95°	100°	105°	110°	115°	120°	125°	130°
10	0.04	0.04	0.05	0.06	0.06	0.07	0.08	0.08	0.09	0.09	0.10	0.10	0.11	0.11	0.11	0.12	0.13	0.14	0.15	0.15
20	0.08	0.08	0.10	0.12	0.13	0.14	0.15	0.16	0.17	0.18	0.19	0.20	0.21	0.22	0.22	0.23	0.26	0.28	0.29	0.30
30	0.12	0.12	0.15	0.18	0.20	0.21	0.23	0.24	0.26	0.27	0.29	0.30	0.32	0.33	0.32	0.35	0.39	0.42	0.44	0.45
40	0.16	0.16	0.20	0.24	0.26	0.28	0.30	0.32	0.34	0.36	0.38	0.40	0.42	0.44	0.43	0.46	0.52	0.56	0.58	0.60
50	0.20	0.20	0.25	0.30	0.33	0.35	0.38	0.40	0.43	0.45	0.48	0.50	0.53	0.55	0.54	0.58	0.65	0.70	0.73	0.75
60	0.24	0.24	0.30	0.36	0.39	0.42	0.45	0.48	0.51	0.54	0.57	0.60	0.63	0.66	0.65	0.69	0.78	0.84	0.87	0.90
70	0.28	0.28	0.35	0.42	0.46	0.49	0.53	0.56	0.60	0.63	0.67	0.70	0.74	0.77	0.76	0.81	0.91	0.98	1.02	1.05
80	0.32	0.32	0.40	0.48	0.52	0.56	0.60	0.64	0.68	0.72	0.76	0.80	0.84	0.88	0.86	0.92	1.04	1.12	1.16	1.20
90	0.36	0.36	0.45	0.54	0.59	0.63	0.68	0.72	0.77	0.81	0.86	0.90	0.95	0.99	0.97	1.04	1.17	1.26	1.31	1.35
100	0.40	0.40	0.50	0.60	0.65	0.70	0.75	0.80	0.85	0.90	0.95	1.00	1.05	1.10	1.08	1.15	1.30	1.40	1.45	1.50
120	0.48	0.48	0.60	0.72	0.78	0.84	0.90	0.96	1.02	1.08	1.14	1.20	1.26	1.32	1.30	1.38	1.56	1.68	1.74	1.80
140	0.56	0.56	0.70	0.84	0.91	0.98	1.05	1.12	1.19	1.26	1.33	1.40	1.47	1.54	1.51	1.61	1.82	1.96	2.03	2.10
160	0.64	0.64	0.80	0.96	1.04	1.12	1.20	1.28	1.36	1.44	1.52	1.60	1.68	1.76	1.73	1.84	2.08	2.24	2.32	2.40
180	0.72	0.72	0.90	1.08	1.17	1.26	1.35	1.44	1.53	1.62	1.71	1.80	1.89	1.98	1.94	2.07	2.34	2.52	2.61	2.70

¹Pipe length baseline temperature = 0°F. "Expansion of Carbon, Copper and Stainless Steel Pipe," *The Engineers' Toolbox*, www.engineeringtoolbox.com.

Figure 25: Coiled Expansion Loops and Offsets (Plan View).

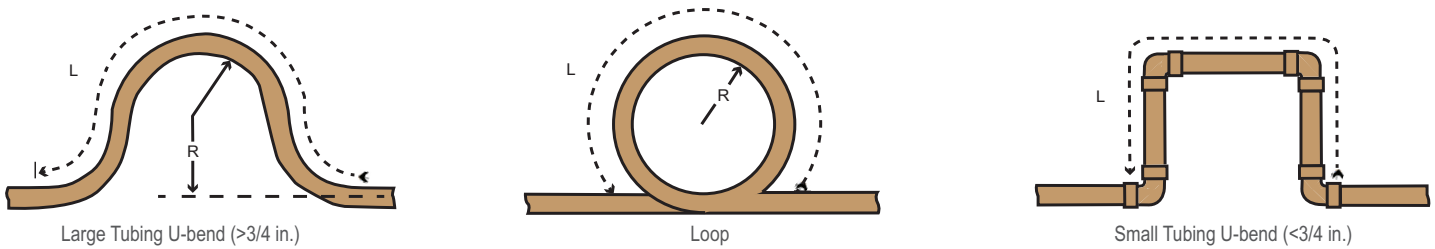

Note:

All expansion loops and offsets must be installed in the horizontal plane to prevent the possibility of trapping oil. Loops and offsets in vertical risers must also be installed in a horizontal plane.

Table 17: Radii of Coiled Expansion Loops and Developed Lengths of Expansion Offsets.

Anticipated Linear Expansion (LE) (inches)		Nominal Tube Size (OD) inches			
		1/4	3/8	1/2	3/4
1/2	R ¹	6	7	8	9
	L ²	38	44	50	59
1	R ¹	9	10	11	13
	L ²	54	63	70	83
1-1/2	R ¹	11	12	14	16
	L ²	66	77	86	101
2	R ¹	12	14	16	19
	L ²	77	89	99	117
2-1/2	R ¹	14	16	18	21
	L ²	86	99	111	131
3	R ¹	15	17	19	23
	L ²	94	109	122	143
3-1/2	R ¹	16	19	21	25
	L ²	102	117	131	155
4	R ¹	17	20	22	26
	L ²	109	126	140	166

¹R = Centerline Length of Pipe.

²L = Centerline Minimum Radius (inches).

Piping Materials and Handling



Pipes used for the refrigerant piping system must include the specified thickness, and the interior must be clean.

While handling and storing,  do not bend or damage the pipes, and take care not to contaminate the interior with dust, moisture, etc.

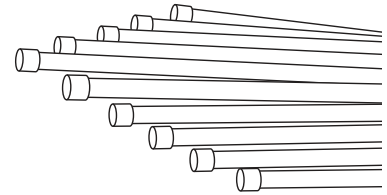
Keep Pipes Capped While Storing.

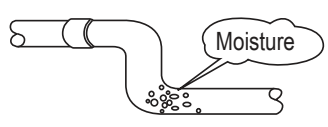
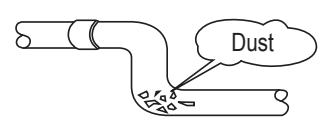
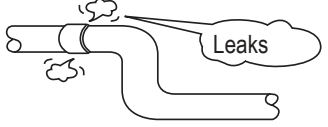

Keep refrigerant pipe dry, clean, and airtight.

	Dry	Clean	Airtight
	No moisture should be inside the piping.	No dust should be inside the piping.	No leaks should occur.
			
Possible Problems	<ul style="list-style-type: none"> - Significant hydrolysis of refrigerant oil. - Refrigerant oil degradation. - Poor insulation of the compressor. - System does not operate properly. - EEVs, capillary tubes are clogged. 	<ul style="list-style-type: none"> - Refrigerant oil degradation. - Poor insulation of the compressor. - System does not operate properly. - EEVs and capillary tubes become clogged. 	<ul style="list-style-type: none"> - Refrigerant gas leaks / shortages. - Refrigerant oil degradation. - Poor insulation of the compressor. - System does not operate properly.
Solutions	<ul style="list-style-type: none"> - Remove moisture from the piping. - Piping ends should remain capped until connections are complete. -  Do not install piping on a rainy day. - Connect piping properly at the unit's side. - Remove caps only after the piping is cut, the burrs are removed, and after passing the piping through the walls. - Evacuate system to a maximum of 500 microns and insure the vacuum holds at that level for 1 hour. 	<ul style="list-style-type: none"> - Remove dust from the piping. - Piping ends should remain capped until connections are complete. - Connect piping properly at the side of the unit. - Remove caps only after the piping is cut and burrs are removed. - Retain the cap on the piping when passing it through walls, etc. 	<ul style="list-style-type: none"> - Test system for air tightness. - Perform brazing procedures that comply with all applicable standards. - Perform flaring procedures that comply with all applicable standards. - Perform flanging procedures that comply with all applicable standards. - Ensure that refrigerant lines are pressure tested to 550 psig and hold for 24 hours.

REFRIGERANT SYSTEM ENGINEERING

Proper system operation depends on the installer using utmost care while assembling the piping system. The following pages are an overview of best practices when installing the refrigerant piping system.

Note:

LG Electronics U.S.A., Inc., is not responsible for any piping calculations, refrigerant leaks, degradation of performance, any other potential problems or damages caused by the interconnecting piping, their joint connections, isolation valves, or introduced debris inside the piping system.

⊘ No Pipe Size Substitutions

Use only the pipe size selected by the information in this manual. Using a different size is prohibited and will result in a system malfunction or failure to work at all.

⊘ No In-line Refrigeration Components

Components such as oil traps, solenoid valves, filter-driers, sight glasses, tee fittings, and other after-market accessories are ⊘ not permitted on the refrigerant piping system between the outdoor units and the indoor units. LG Single Zone systems are provided with redundant systems that make sure oil is properly returned to the compressor. Sight-glasses and solenoid valves will cause vapor to form in the liquid stream. Over time, driers will deteriorate and introduce debris into the system. The designer and installer must verify the refrigerant piping system is free of traps, sagging pipes, sight glasses, filter driers, etc.

Field-Provided Isolation Ball Valves

LG maintains a neutral position on using isolation valves in LG HVAC refrigerant piping systems. LG does not endorse any manufacturer of isolation valves. It is recognized that installing isolation valves will simplify future maintenance requirements, and, if used, considerations must be taken including, but not limited to, the following:

- Pressure drops for any component used, including isolation valves, must be known in equivalent pipe length and calculated into the total and segment equivalent piping lengths and compared to product design limitations.
- In all cases, materials must be suitable for the application and any applicable codes, including, but not limited to, diameter and wall thickness continuity per ACR standards.

Failure to do so will cause significant performance degradation. Proper leak checks must be performed. Using isolation valves does not automatically void any LG product warranty, however, a limited warranty will be voided in whole or part if any field supplied accessory fail in any way that causes product failure.

Using Elbows

Field-supplied elbows are allowed if they are long radius and designed for use with R410A refrigerant. The designer and installer, however, must be cautious with the quantity and size of fittings used, and must account for the additional pressure losses in equivalent pipe length calculation for each branch. The equivalent pipe length of each elbow must be added to each pipe segment manually (see table).

Table 18: Equivalent Piping Length for Elbows.

Component	Size (Inches)				
	1/4	3/8	1/2	5/8	3/4
Elbow (ft.)	0.5	0.6	0.7	0.8	1.2

Pipe Bends

When bending soft copper, use long radius bends. Refer to the "Radii of Coiled Expansion Loops and Developed Lengths of Expansion Offsets" table for minimum radius specifications.

Obstacles

When an obstacle, such as an I-beam or concrete T, is in the path of the planned refrigerant pipe run, it is best practice to route the pipe over the obstacle. If adequate space is not available to route the insulated pipe over the obstacle, then route the pipe under the obstacle. In either case, it is imperative the length of the horizontal section of pipe above or below the obstacle be a minimum of three (3) times the longest vertical rise (or fall) at either end of the segment.

Figure 26: Installing Piping Above and Below an Obstacle.

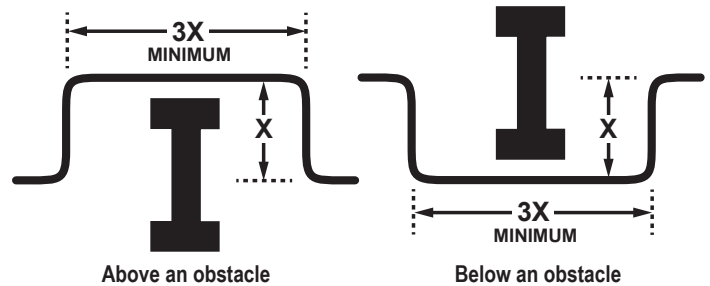

Pipe Supports

A properly installed pipe system must be adequately supported to avoid pipe sagging. Sagging pipes become oil traps that lead to equipment malfunction.

Pipe supports must \odot never touch the pipe wall; supports must be installed outside (around) the primary pipe insulation jacket. Insulate the pipe first because pipe supports must be installed outside (around) the primary pipe insulation jacket. Clevis hangers must be used with shields between the hangers and insulation. Field provided pipe supports must be designed to meet local codes. If allowed by code, use fiber straps or split-ring hangers suspended from the ceiling on all-thread rods (fiber straps or split ring hangers can be used as long as they do not compress the pipe insulation). Place a second layer of insulation over the pipe insulation jacket to prevent chafing and compression of the primary insulation within the confines of the support pipe clamp.

A properly installed pipe system will have sufficient supports to avoid pipes from sagging during the life of the system. As necessary, place supports closer for segments where potential sagging could occur. Maximum spacing of pipe supports must meet local codes. If local codes do not specify pipe support spacing, pipe must be supported:

- Maximum of five (5) feet on center for straight segments of pipe up to 3/4 inches outside diameter size.
- Maximum of six (6) feet on center for pipe up to one (1) inch outside diameter size.
- Maximum of eight (8) feet on center for pipe up to two (2) inches outside diameter size.

Wherever the pipe changes direction, place a hanger within twelve (12) inches on one side and within twelve (12) to nineteen (19) inches of the bend on the other side.

Figure 27: Pipe Hanger Details.

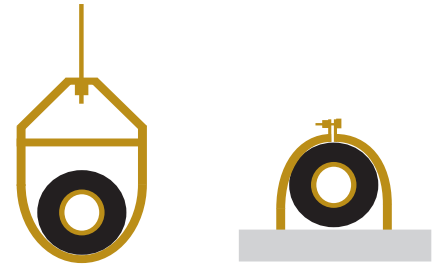

Note:

Use a 4" + long sheet curved sheet metal saddles between hanger bracket and insulation to promote linear expansion/contraction.

Figure 28: Typical Pipe Support Location—Change in Pipe Direction.

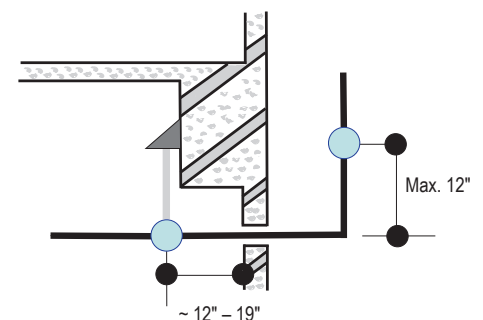

REFRIGERANT SYSTEM ENGINEERING

Pipe Sleeves at Penetrations

LG recommends that all pipe penetrations through walls and floors be properly insulated and routed through an appropriate wall sleeve of sufficient size to prevent compression of refrigerant pipe insulation and free movement of the pipe within the sleeve. Use 4"+ curved sheet metal saddles between the bottom surface of the pipe and the bottom surface of the penetration.

Figure 29: Pipe Sleeve Options.

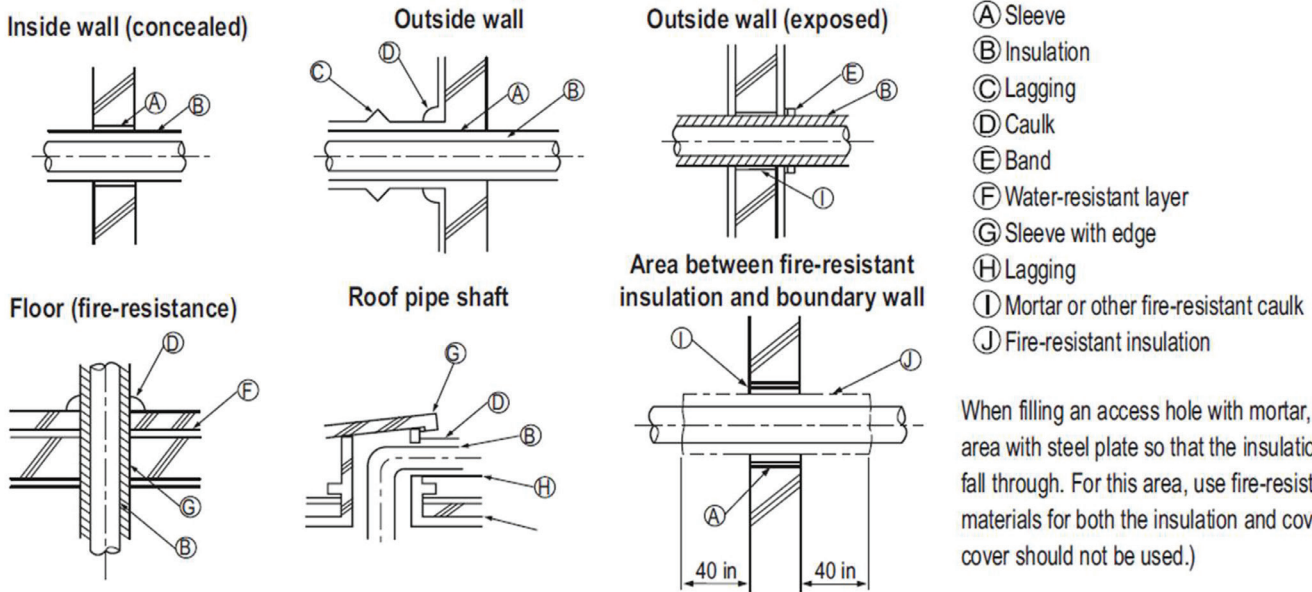

Note:

Diameter of penetrations must be determined by pipe diameter plus the thickness of the insulation.

FLARING AND BRAZING PROCEDURES

Flaring and Brazing Procedures

One of the main causes of refrigerant leaks is a defective connection. For LG HVAC systems, the installer needs to know how to perform both flared and brazed connections successfully.

Note:

- During installation, it is imperative to keep the piping system free of contaminants and debris such as copper burrs, slag, or carbon dust.
- Do not use kinked pipe caused by excessive bending in one specific area on its length.

Flaring Procedure

Note:

When selecting flare fittings, always use a 45° fitting rated for use with high pressure refrigerant R410A. Selected fittings must also comply with local, state, or federal standards.

1. Cut the pipe to length.

- Measure the distance between the indoor unit and the outdoor unit.
- Cut the pipes a little longer than measured distance.

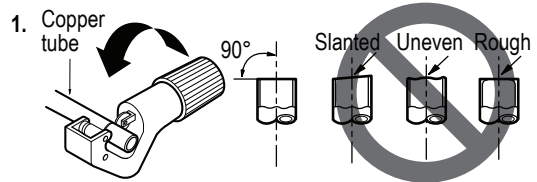

2A. Remove the burrs.

- Completely remove all burrs from pipe ends.
- When removing burrs, point the end of the copper pipe down to avoid introducing foreign materials in the pipe.

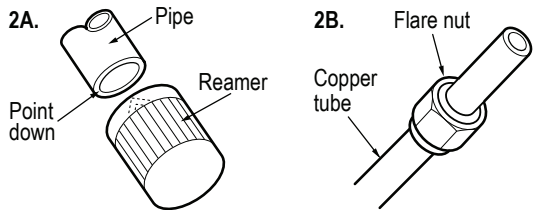

2B. Slide the flare nut onto the copper tube.

3. Flaring the pipe end.

- Use the proper size flaring tool to finish flared connections as shown.
- ALWAYS create a 45° flare when working with R410A.

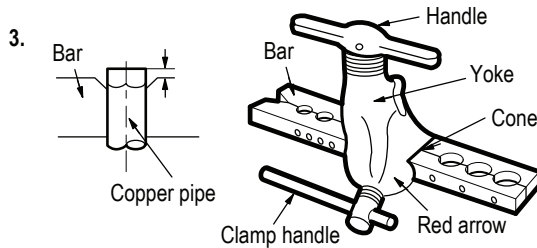

4. Carefully inspect the flared pipe end.

- Compare the geometry with the figure to the right
- If the flare is defective, cut it off and re-do procedure.
- If flare looks good, blow the pipe clean with dry nitrogen.

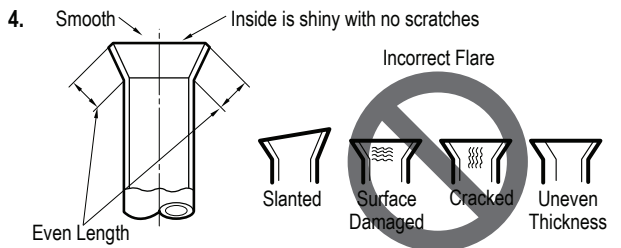

Dimensions of the Flare.

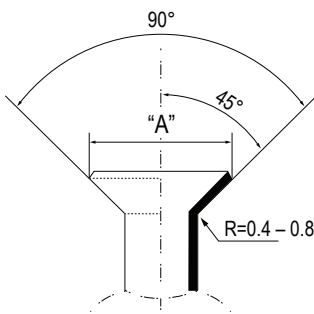

Flared Connection Dimensions / Tightening Torque.

Pipe Size (in. O.D.)	Outside Diameter (mm)	"A" Dimension (mm [in.])
1/4	6.35	~ 9.1 (11/32 - 23/64)
3/8	9.52	~ 13.2 (1/2 - 33/64)
1/2	12.7	~ 16.6 (41/64 - 21/32)
5/8	15.88	~ 19.7 (49/64 - 25/32)
3/4	19.05	-

FLARING AND BRAZING PROCEDURES

Tightening the Flare Nuts

Tightening Torque for Flare Nuts.

Pipe Size (in. O.D.)	Outside Diameter (mm)	Tightening Torque (ft.-lbs.)
1/4	6.35	13.0 - 18.0
3/8	9.52	24.6 - 30.4
1/2	12.7	39.8 - 47.7
5/8	15.88	45.4 - 59.3
3/4	19.05	71.5 - 87.5

1. When connecting the flare nuts, coat the flare (outside only) with polyvinyl ether (PVE) refrigeration oil only.

Note:

- ⊘ Do not use polyolylester (POE) or any other type of mineral oil as a thread lubricant. These lubricants are not compatible with the PVE oil used in this system and create oil sludge leading to equipment damage and system malfunction.
- ⊘ Do not add any contaminants inside the refrigerant piping.

2. Initially hand tighten the flare nuts using three (3) or four (4) turns.
3. To finish tightening the flare nuts, use both a torque wrench and a backup wrench.
4. After all the piping has been connected and the caps have been tightened, check for refrigerant gas leaks.

Loosening the Flare Nuts

Always use two (2) wrenches to loosen the flare nuts.

Brazing Practices

⚠ WARNING

- ⊘ Do not braze in an enclosed location. ⊘ Do not allow the refrigerant to leak during brazing. Always test for gas leaks before and after brazing.

If the refrigerant combusts, it generates a toxic gas that will cause physical injury or death.

1. Joints are brazed in the field. Single Zone refrigeration system components contain very small capillary tubes, small orifices, electronic expansion valves, oil separators, and heat exchangers that can easily become blocked. Proper system operation depends on the installer using best practices and utmost care while assembling the piping system.
2. Store pipe stock in a dry place; keep stored pipe capped and clean.
3. Blow clean all pipe sections with dry nitrogen prior to assembly.
4. Always use a non-oxidizing material for brazing. ⊘ Do not use flux, soft solder, or anti-oxidant agents. If the proper material is not used, oxidized film will accumulate and clog or damage the compressors. Flux can harm the copper piping or refrigerant oil.
5. Use a tubing cutter, ⊘ do not use a saw to cut pipe. De-bur and clean all cuts before assembly.
6. Brazing joints:
 - Use a dry nitrogen purge operating at a minimum pressure of three (3) psig and maintain a steady flow.
 - Use a 15% silver phosphorous copper brazing alloy to avoid overheating and produce good flow.
 - Protect isolation valves, electronic expansion valves, and other heat-sensitive control components from excessive heat with a wet rag or heat barrier spray.

Figure 30: Refrigerant Pipe Brazing.

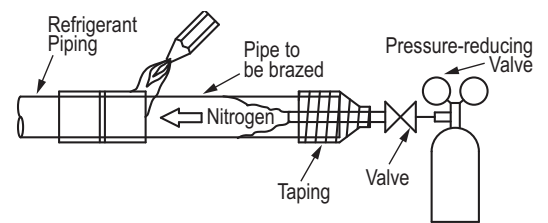

⚠ WARNING

- ⊘ Do not allow the refrigerant to leak during brazing; if the refrigerant combusts, it generates a toxic gas. There is risk of fire, explosion, and physical injury or death.
- ⊘ Do not braze in an enclosed location, and always test for gas leaks before / after brazing. There is risk of fire, explosion, and physical injury or death.

REFRIGERANT PIPING

Installation Overview / Special Applications

Installation

Single Zone Mid-Static Ducted systems are one-to-one systems. There is a direct piping connection between the outdoor unit and the indoor unit. The majority of installations have the indoor unit being installed at a higher position than the outdoor unit. However, if the outdoor unit be installed at a higher position than the indoor unit, the basic pipe connections are the same (see below). Refer to the tables in the “Connection Limitations” section for specific length limitations in conjunction with outdoor unit and indoor unit positioning.

NOTE

- When proceeding with piping connections, follow pipe support spacing lengths as shown in the “General Refrigerant Piping System” Information section. Refer to the “Pipe Supports” section for information on using clamps and pipe support materials.
- Always follow local codes regarding piping and accurate support spacing along the piping system.
- Always include insulation on all refrigerant and drain piping to ensure condensate does not form and cause damage to walls, floors, etc.

Special Applications

If an additional drain hose is necessary, the end of the drain outlet must be routed above the ground. Secure the drain hose appropriately.

When the Outdoor Unit is Installed Below the Indoor Unit:

1. Use a conduit, piping set cover, or bundle the (separately) insulated refrigerant piping, the drain hose, and the communications / connection (power) cable together.
2. Make sure to include some slack in the wiring. Wiring must be installed in an upwards direction to prevent water from accessing into the control box.
3. Secure the conduit, piping set cover, or bundle along the outside wall using saddles or a similar type of piping support.
4. Seal any openings in the wall that are around the piping.

When the Outdoor Unit is Installed Above the Indoor Unit:

1. Use a piping set cover, or bundle the (separately) insulated refrigerant piping and the communications / connection (power) cable together up to the outdoor unit service valves.
2. Make sure to include some slack in the wiring. Wiring must be installed in upwards direction to prevent water from accessing the control box.
3. If necessary, secure the piping set cover or bundle along the outside wall using saddles or a similar type of piping support.
4. Ensure the drain hose from the indoor unit is installed away from the outdoor unit, and in a downward direction. If necessary, secure along the outside wall using saddles or a similar type of support.
5. Seal any openings in the wall that are around the piping.

Note:

For information about bundling, see the Bundling page in this section. For information about using a conduit to protect the wiring between the outdoor unit and the indoor unit, see the in the Electrical System Installation section.

Figure 31: Special Applications. (For Illustrative Purposes. Appearance and Connection Locations Will Differ Depending On Outdoor Unit Model.)

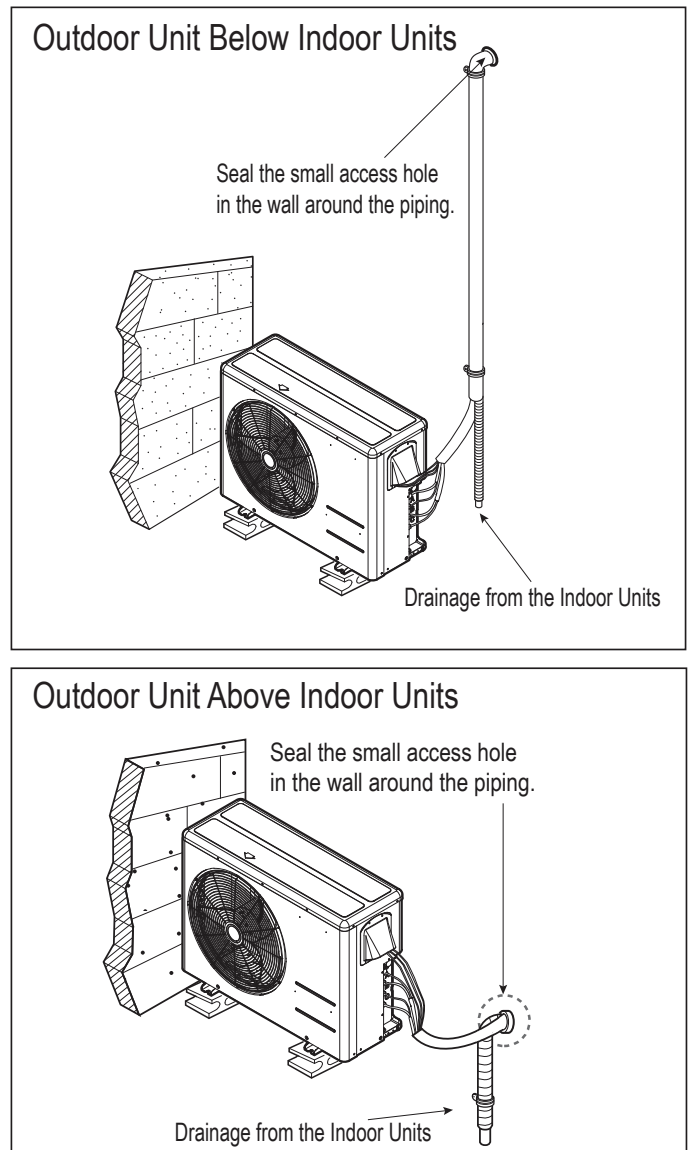

REFRIGERANT PIPING

Outdoor Unit Connections

Outdoor Unit Connection Installation

1. Remove the piping cover and / or piping / control box cover (configuration depends on outdoor unit model) from the unit by loosening the fastening screws.
2. Refer to the figures below for liquid and gas (vapor) piping attachments onto the outdoor unit.
3. Remove the flare nuts attached to the outdoor unit valves.
4. Thread the flare nuts onto the field-supplied piping.
5. Flare the end of the piping following the information in the “General Refrigerant Piping System” section and industry best practices.
6. Place a couple of drops of PVE refrigerant oil on outside of the flare before assembling. ⚠ Do not add any contaminants.
7. Align the center of the refrigerant piping and corresponding connection as shown below and on the next page.
8. Connect the field piping to the outdoor unit connection. Tighten the flare nut initially by hand.
9. Finish tightening the flare nut with a torque wrench until the wrench clicks. Follow torque guidelines in the table below. See figures for correct connection points.

Figure 32: LUU090HV, LUU120HV, LUU180HV, and LUU240HV Piping / Control Box Cover Removal (Appearances Will Differ Depending on Model).

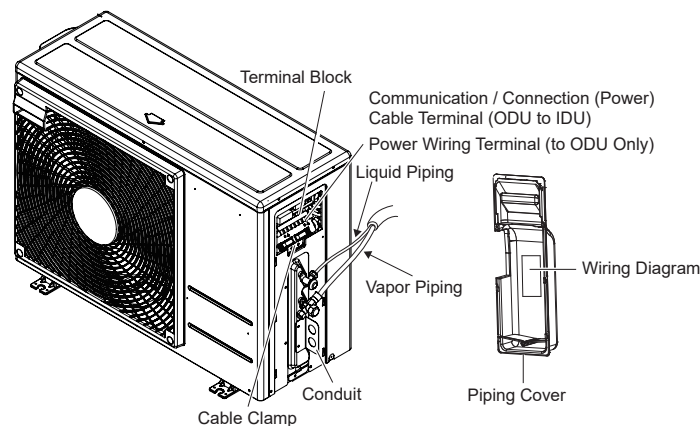

Figure 34: Removing the Flare Nuts on the Outdoor Unit.

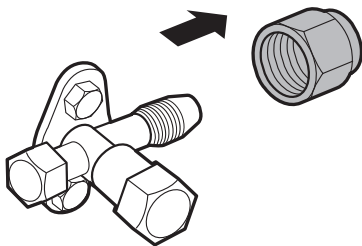

Figure 33: LUU090HV, LUU120HV, LUU180HV, and LUU240HV Piping Connections (Appearances Will Differ Depending on Model).

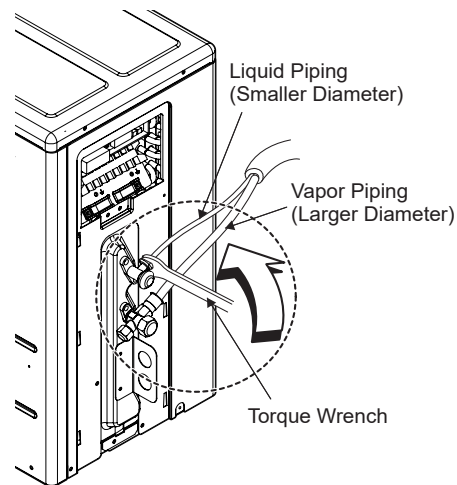

Figure 35: Connecting the Flared Field Piping to the Outdoor Unit Connection.

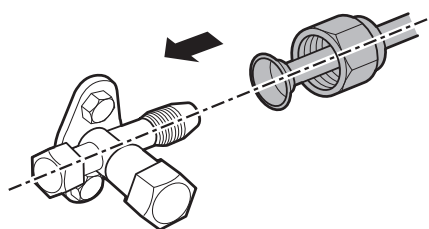

Table 19: Torque Wrench Tightening.

Pipe Size (in. O.D.)	Outside Diameter (mm)	Torque (ft-lbs.)
1/4	6.35	13.0 - 18.0
3/8	9.52	24.6 - 30.4
1/2	12.7	39.8 - 47.7
5/8	15.88	45.4 - 59.3
3/4	19.05	71.5 - 87.5

Note:

- When tightening the flare nut with a torque wrench, ensure the direction for tightening follows the arrow on the wrench.
- To prevent insects or small animals from entering and damaging interior components, plug gaps / access holes with field-supplied putty or insulation.

REFRIGERANT PIPING

Indoor Unit Connections

Indoor Unit Piping Installation

Note:

See the *Electrical System Installation* section for information on how to connect the communication / connection (power) wiring from the outdoor unit.

1. Remove the flare nuts attached to the indoor unit piping. To remove, hold onto the piping with an adjustable wrench, and then loosen the flare nut with a torque wrench.
2. Thread the flare nuts onto the field-supplied piping.
3. Flare the end of the piping following industry best practices, and the information in the "General Refrigerant Piping System" section.
4. Place a couple of drops of PVE refrigerant oil on outside of the flare before assembling. ⚠ Do not add any contaminants.
5. Align the center of the refrigerant field piping to the corresponding indoor unit piping.
6. Connect the refrigerant field piping to the indoor unit piping. First, hold onto the piping with an adjustable wrench. Tighten the flare nut initially by hand, and then finishing tightening using a torque wrench. Follow torque guidelines in the table.

Figure 36: Indoor Unit Connection.

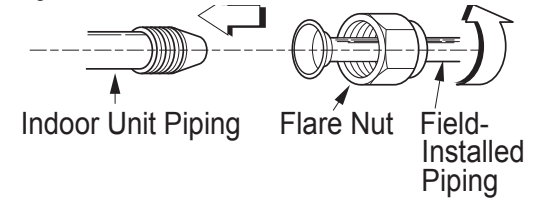

Table 20: Torque Wrench Tightening.

Pipe Size (in. O.D.)	Outside Diameter (mm)	Torque (ft.-lbs.)
1/4	6.35	13.0 - 18.0
3/8	9.52	24.6 - 30.4
1/2	12.7	39.8 - 47.7
5/8	15.88	45.4 - 59.3
3/4	19.05	71.5 - 87.5

Note:

When tightening the flare nut with a torque wrench, ensure the direction for the tightening follows the arrow on the wrench.

7. If bundling the refrigerant piping, the drain piping, and communication / connection (power) together, ensure that the drain piping is located at the bottom of the bundle.
- If using a conduit for the power wiring / communications cable, see next page.

Note:

Positioning the drain hose at the top of the bundle can cause condensate to overflow from the inside of the indoor unit.

18,000 Btu/h Mid-Static Ducted Indoor Unit to 18,000 Btu/h Single-Zone Outdoor Unit Refrigerant Piping Connections

The 18,000 Btu/h mid-static ducted indoor unit requires connectors to be used with 18,000 Btu/h single zone outdoor units. The connectors listed below are included with the 18,000 Btu/h indoor unit. Follow piping installation and torque tightening procedures above when installing the connectors.

Table 21: Refrigerant Connection Piping Sizes.

Outdoor Unit Type	Capacity (Btu/h)	Refrigerant Connection Piping Sizes	
		Liquid	Gas
Single Zone	18,000	3/8 (Ø9.52)	5/8 (Ø15.88)

Table 22: Included 18,000 Btu/h Mid-Static Connectors.

Connectors (included only for single-zone system installations)	
	One (1) Each for Ø3/8 inch → Ø1/2 inch
	One (1) Each for Ø5/8 inch → Ø1/2 inch
	One (1) Each for Ø1/4 inch → Ø3/8 inch

Figure 37: LHN188HV1 Mid Static Duct Indoor Unit Refrigerant Pipe Connections.

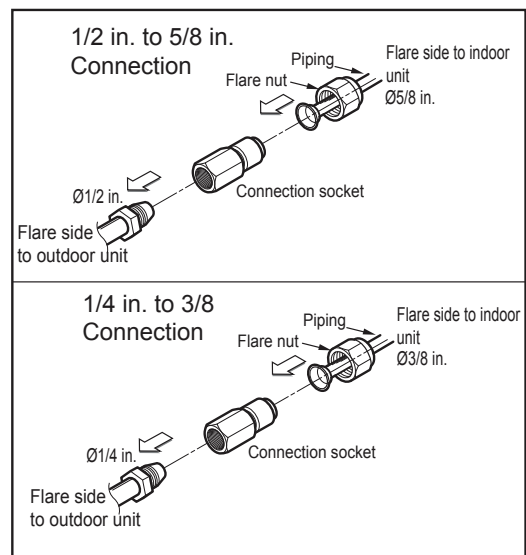

CONDENSATE PIPING

Outdoor Unit Condensate Piping / Indoor Unit Condensate Piping

Outdoor Unit Condensate Drain Piping

Outdoor unit requires condensate drain piping. Condensate drain pipe is constructed with materials approved by federal, state, and local codes. See the "Placement Considerations" section for information in reference to outdoor unit placement.

Indoor Unit Condensate Piping Installation

Figure 38: Indoor Unit Slight Incline Installation.

Horizontal Applications

Mid-static ducted indoor units include a flexible drain hose and two clamps. The hose can be used to connect the condensate pipe to the condensate pump connection. On mid-static units, there is the option to directly connect a 3/4 inch FPT fitting to the drain pan's gravity drain connection (see next pages for gravity drain information).

- Ensure that the mid-static ducted indoor unit is installed with a slight incline in the direction to the drain hose connection. See the "Installation" section for details.

- Any holes through the ceilings, walls etc., must be large enough to accommodate the drain piping and insulation. (See the Insulation section for more information. See also local, state, and federal codes.)

- The drain pump has a height of up to 27-9/16 inches to remove condensate. To ensure proper drainage, the factory-supplied flexible drain hose and any field-supplied drain piping must be installed below the maximum height.

- Install any drain lift piping at a right angle to the indoor unit, and no more than 11-13/16 inches (300mm) from the unit.

- Field-supplied drain piping must have downward gradient away from the unit of at least 1/50 to 1/100. To prevent reverse flow, do not vertically slope the drain piping.

- Route the flexible drain pipe to the indoor unit, connect the flexible drain pipe to the indoor unit drain port, and then connect the flexible drain pipe to the field-supplied drain piping.

- When connecting the flexible drain hose or field-supplied drain piping, do not damage the drain port on the indoor unit.

- Dimensions on the indoor unit drain connection is 1-1/4 inches (32mm) outside diameter.

- Use polyvinyl chloride VP25 pipe and pipe fittings for the condensate piping.

- After drain hose is installed and tested, insulate with polyethylene foam more than 0.3 inches (8mm) thick (check local, state, and federal codes). Position snugly against the indoor unit frame.

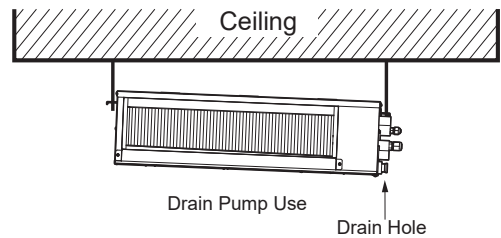
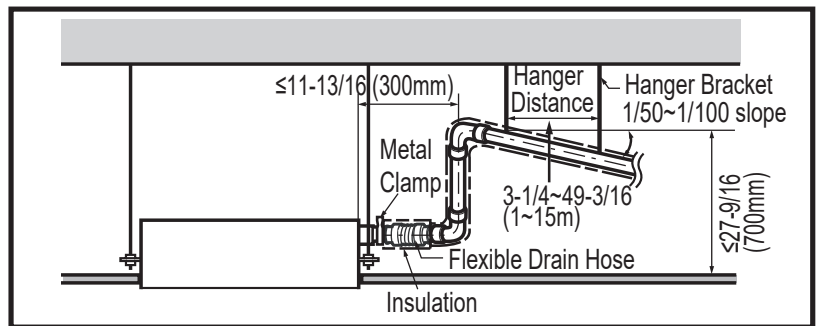

Figure 39: Drain Piping Installation Specifications.



- Install any drain lift piping at a right angle to the indoor unit, and no more than 11-13/16 inches (300mm) from the unit.

- Field-supplied drain piping must have downward gradient away from the unit of at least 1/50 to 1/100. To prevent reverse flow, do not vertically slope the drain piping.

- Route the flexible drain pipe to the indoor unit, connect the flexible drain pipe to the indoor unit drain port, and then connect the flexible drain pipe to the field-supplied drain piping.

- When connecting the flexible drain hose or field-supplied drain piping, do not damage the drain port on the indoor unit.

- Dimensions on the indoor unit drain connection is 1-1/4 inches (32mm) outside diameter.

- Use polyvinyl chloride VP25 pipe and pipe fittings for the condensate piping.

- After drain hose is installed and tested, insulate with polyethylene foam more than 0.3 inches (8mm) thick (check local, state, and federal codes). Position snugly against the indoor unit frame.

Figure 40: Do Not Route the Piping Upward.

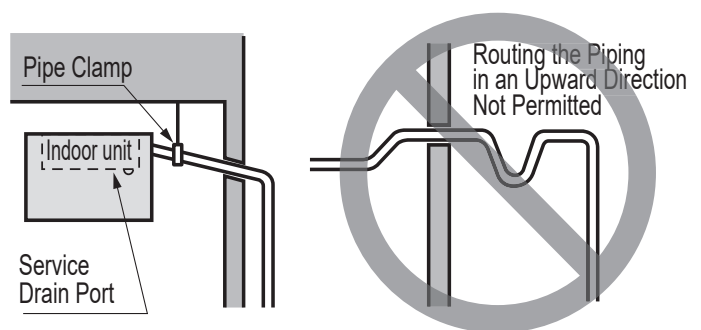

NOTE

Do NOT install the supplied flexible drain hose with a sharp curve or twist. A curved or twisted flexible hose will become damaged due to vibration and / or leak.

CONDENSATE PIPING

Vertical Condensate Piping / Common Drain System

Vertical Application Condensate Piping Connections

- Connect the drain piping to drain hole of vertical drain pan.
- Block the drain hole of drain pump to prevent air leaks.

Figure 41: Vertical Condensate Piping Connections.

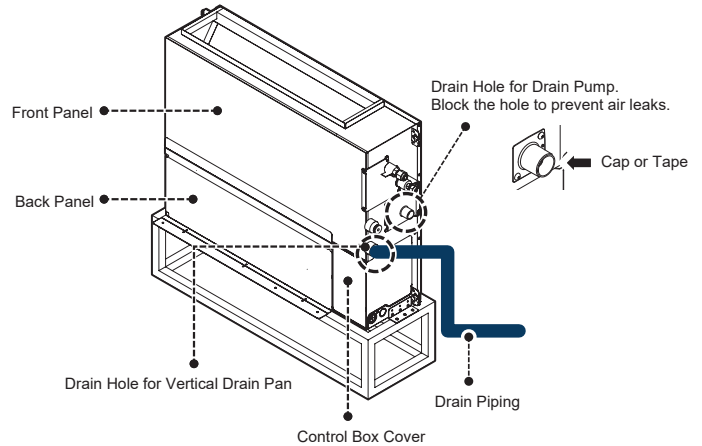

Common Drain System Information

Note:

Condensate can be drained either directly outside or to a common drain system. For more information regarding the common drain system, see below or the Multi F / Multi F MAX with LGRED Outdoor Unit Engineering Manual or the regular Multi F / Multi F MAX Outdoor Unit Engineering Manual.

If the field drain piping and / or the common drain system is long, install clamp hangers for support.

Table 23: Required Drain Piping Support Intervals.

Piping Dia. (Inch)	Ø3/4" ~ 1-1/2"	Ø1-1/2" ~ 2"	Ø2-1/2" ~ 5"
Maximum Interval (feet)	<3.3	<3.9	<4.9

Ducted Unit Common Drain System Information

If the bottom surface of the ducted indoor unit is at an elevation below a receiving building drain line connection, install an inverted trap at the top of the condensate pump discharge riser before connection to the building drain pipe.

If the receiving drain line is mounted horizontally, connect the inverted trap to the top half of the pipe. The connection point of the inverted trap to the building drain pipe should always be to the top half of the pipe and should never be over 45° either side of the upper most point of the horizontal building drain line.

If connecting to a vertical drain line or plumbing system vent line, connect the IDU condensate pump discharge line using a Y-45 fitting with the double end of the Y-45 fitting facing up. When connecting to a vertical drain line include an inverted trap at the top of the IDU condensate pump discharge riser before connection to the Y-45 fitting.

Figure 42: Close Up of Drain Hole.

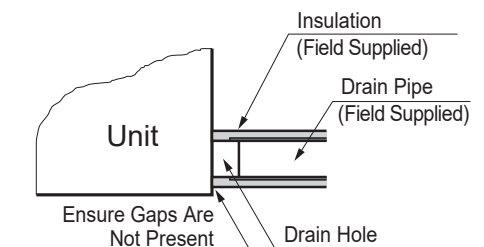

CONDENSATE PIPING

Gravity Condensate Pipe / Checking for Leaks

Gravity Condensate Pipe Connection

Mid-static indoor units have an auxiliary gravity condensate drain connection. This connection may be used instead of using the condensate pump. If the gravity drain is used, disconnect the indoor unit condensate pump connector on the indoor unit PCB.

- Verify the unit is installed with a slight incline toward the gravity drain connection.
- Remove the rubber plug before connecting the condensate line to the indoor unit, if present.
- The gravity condensate for mid-static indoor units can be equipped with a condensate trap for proper condensate flow. See Figure at right for trap details.
- Horizontal segments of condensate pipe should be sloped a minimum of 1/4 inch per foot away from the indoor unit.

Note:

Install a U-Trap / P-Trap to prevent water leaks caused by suction air blockage.

Figure 43: U-Trap Dimensions.

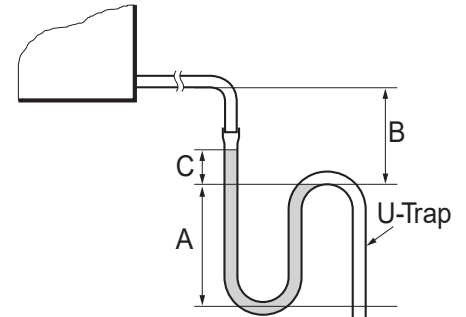

Applied U-Trap Dimensions

$A \geq 2\text{-}3/4$ inches

$B \geq 2C$

$C \geq 2 \times \text{SP}$

SP = External Pressure (in. Aq.)

Example: External Pressure = 0.39 in. Aq.

$A \geq 2\text{-}3/4$ inches.

$B \geq 1\text{-}9/16$ inches.

$C \geq 25/32$ inches.

Checking the Indoor Unit and Drain Piping for Leaks

To test the flexible drain hose and field-supplied drain piping:

- Connect the flexible drain hose to the field-supplied drain piping (that drains to the outside).
- Pour water into the flexible drain hose and check for leaks.
- Repair any leaks if necessary.

To test the evaporator:

- Remove air filter, if present.
- Connect the flexible drain hose to the indoor unit drain port.
- Spray one (1) or two (2) glasses of water on the evaporator. Verify the water flows out of the drain hose without leaks.
- Repair any leaks if necessary.
- After power wiring installation is complete, operate the drain pump to see if it sounds and functions properly.

Figure 44: Checking the Drain Piping.

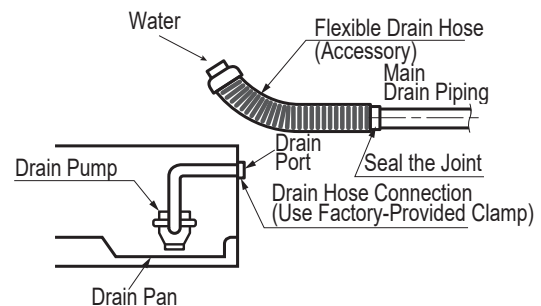
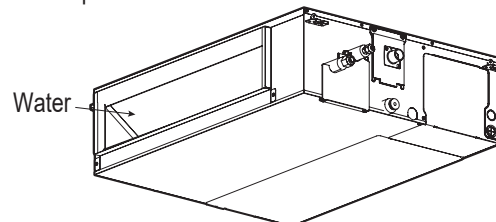

Figure 45: Evaporator Drain Test.



CONDENSATE PIPING

Bundling

Bundling

If a conduit or piping set cover is not used on the connection from the outdoor unit to the interior, bundle both separately insulated refrigerant pipes, the drain hose, and outdoor unit to indoor unit communication / connection (power) cable together with wide vinyl tape.

1. Both piping must be fully and separately encased in insulation material: Overlap the field installation piping insulation material and the indoor unit piping insulation material. Verify that any insulation material cutting lines are placed upward.
2. Bind together the two pipes, using narrow vinyl tape. Make sure there are no gaps during the binding.
3. Continue to wrap the indoor unit pipe as connected to the outdoor connection pipe.
4. Using a wider vinyl tape, bundle the piping and drain hose together, if applicable. Install the wider vinyl tape from the bottom up.
 - Tape must be sufficient to cover the piping in order to fit into the rear piping housing area at the back of the indoor unit.

NOTE

- Always include insulation on all refrigerant and drain hose to ensure condensate does not form and cause damage to walls, floors, etc. See insulation section for more information.
- Positioning the drain hose at the top of the bundle can cause condensate to overflow from the drain pan in the inside of the indoor unit.

Figure 46: Bundling the Connection Components (From Outdoor Unit to Indoor Unit).

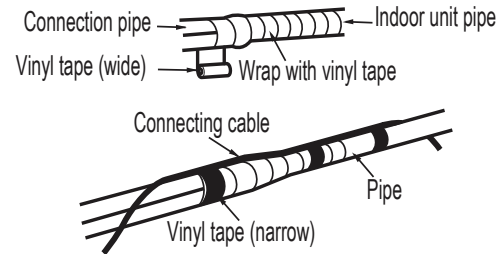

Figure 47: Cut Line Position.

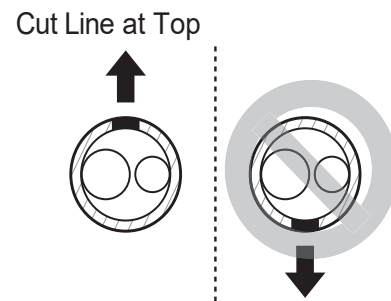
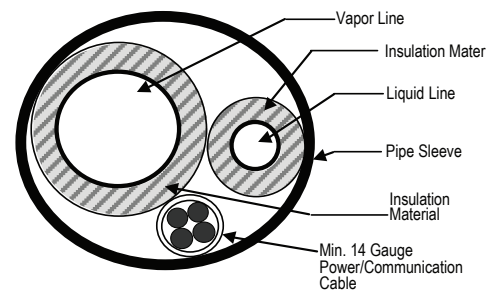

Figure 48: Cutaway of Proper Pipe and Cable Bundling.



INSULATION

Refrigerant Piping System Insulation

All refrigerant piping from the outdoor unit to the indoor units must be insulated correctly for safety and usage. Refrigerant piping, field-provided isolation ball valves (if present), service valves, and elbows must be properly and completely insulated using closed cell pipe insulation (up to the indoor unit piping connections). To prevent heat loss / heat gain through the refrigerant piping, all refrigerant piping including liquid lines and vapor lines must be insulated separately. Insulation must be a minimum 1/2 inches thick, and thickness will need to be increased based on ambient conditions and local codes. Table on next page lists minimum wall thickness requirements for Ethylene Propylene Diene Methylene (EPDM) insulation.

Inside the outdoor unit, maximum pipe temperature is 248°F and minimum pipe temperature is -40°F. For field insulation of refrigerant piping between outdoor units and indoor units, consider the following pipe temperature ranges for an operating heat pump system:

- Heating mode refrigerant temperature ranges: Liquid = 75-118°F; High Pressure Vapor = 95-220°F
- Cooling mode refrigerant temperature ranges: Liquid = 75-118°F; Low Pressure Vapor = 40-90°F

All insulation joints must be glued with no air gaps. Insulation material must fit snugly against the refrigeration pipe with no air space between it and the pipe. ⚠ Do not allow insulation passing through pipe hangers, inside conduit, and/or sleeves to be compressed. Protect insulation inside hangers and supports with a second layer. All pipe insulation exposed to the sun and outdoor elements must be properly protected with PVC, aluminum vapor barrier, or alternatively placed in a weather-resistant enclosure such as a pipe rack with a top cover; and meet local codes.

Figure 49: Typical Insulation at the Mid-Static Ducted Indoor Unit.

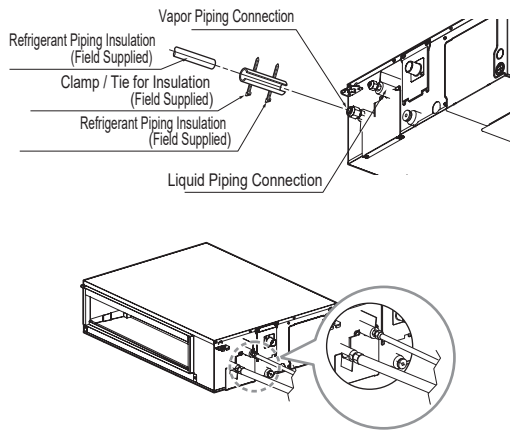

Figure 50: Typical Insulation Butt-Joint at Indoor Unit Casing.

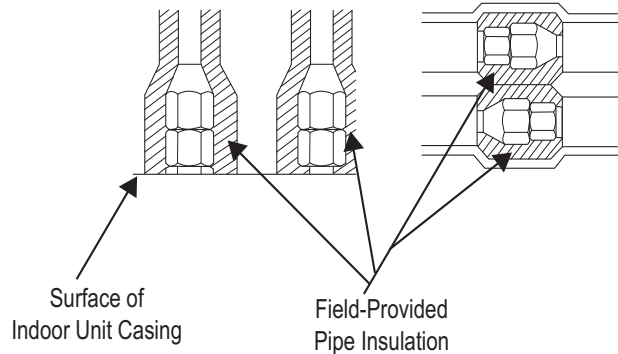

Figure 51: Typical Refrigerant Flare Fitting Insulation Detail.

Figure 52: Close Up of Typical Insulation at the Indoor Unit.

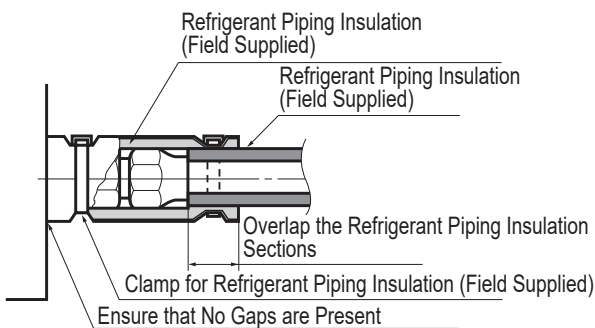
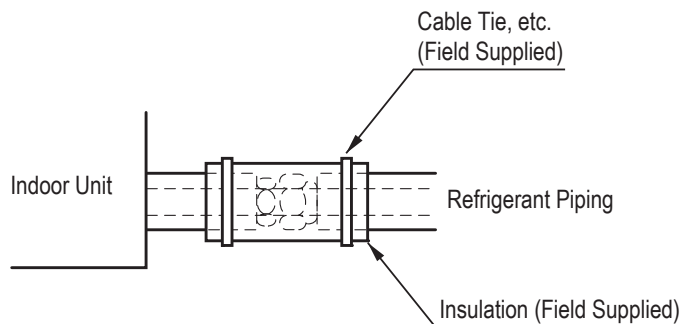

Figure 53: Insulating the Shut Off / Insulation Ball Valve (If Present).



NOTE

Always include plenty of insulation on all refrigerant and drain piping to ensure condensate does not form and cause damage to walls, floors, etc.

Minimum Refrigerant Pipe Ethylene Propylene Diene Methylene (EPDM) Insulation Wall Thickness Requirements

Note:

- Ⓞ Do not insulate gas and liquid pipes together as this can result in pipe leakage and malfunction due to extreme temperature fluctuations.
- Always properly insulate the piping. Insufficient insulation will result in condensation, reduced heating/cooling performance, etc. Also, if the pipes aren't insulated properly, condensation could potentially cause damage to building finishes. Pay special attention to insulating the pipes installed in the ceiling plenum.
- Fully insulate the piping connections.
- Follow local codes and the designer's instructions when selecting ethylene propylene diene methylene (EPDM) insulation wall thickness.

Table 24: Minimum Refrigerant Pipe EPDM Insulation Wall Thickness Requirements.¹

Classification / Piping O.D.		Air-conditioned location		Non-air conditioned location	
		1. Typical Conditioned Location	2. Special Conditioned Location	3. Typical Unconditioned Location	4. Special Unconditioned Location
Liquid pipe	ø1/4 inch	≥1/2 inches	≥1/2 inches	≥1/2 inches	≥1/2 inches
	ø3/8 inch				
	≥ø1/2 inch				
Vapor pipe	ø3/8 inch	≥1/2 inches	≥3/4 inches	≥3/4 inches	≥1 inch
	ø1/2 inch				
	ø5/8 inch				
	ø3/4 inch				
	ø7/8 inch				
	ø1 inch	≥3/4 inches	≥1 inch	≥1 inch	
	ø1-1/8 inches				
	ø1-1/4 inches				
	ø1-3/8 inches				
	ø1-1/2 inches				
ø1-3/4 inches					

¹The thickness of the above insulation material is based on heat conductivity of 0.61 Btu/in/h/ft²/°F.

1. Typical Conditioned Location

A building plenum or space that contains conditioned air that does not exceed 80°F DB.

2. Special Conditioned Location

1. When the location is air conditioned, but there is severe temperature/humidity difference due to high ceilings.
 - Church, auditorium, theater, lobby, etc.
2. When the location is air conditioned, but internal temperature/humidity are high.
 - Bathroom, swimming pool, locker room, etc.

3. Typical Unconditioned Location

An unconditioned space inside a building.

4. Special Unconditioned Location: If conditions 1 and 2 below are present.

1. An unconditioned space or plenum of a building.
2. An area where there is an elevated humidity level.

5. Additional Insulation for Indoor Units May be Required in Humid Environments.

The air conditioner factory insulation has been tested according to "ISO Conditions with Mist," and it satisfies the requirements. If the system has been operating for a long time in a high humidity environment (dew point temperature: more than 73°F), condensate is likely to form. If this happens, install 3/8 inch thick EPDM insulation that is plenum-rated with a heat-resistance factor of more than 248°F.

ELECTRICAL SYSTEM INSTALLATION

Safety Guidelines / Connections and Specifications

⚠ WARNING

- All power wiring and communication cable installation must be performed by trained service providers working in accordance with local, state, and National Electrical Code (NEC) / UL / ETL federal regulations related to electrical equipment and wiring, and following the manufacturer product diagrams, requirements, and instructions in this manual. Failure to do so will lead to electric shock which can cause physical injury or death.
- Verify that main power to the unit is completely off before proceeding. Follow all safety and warning information outlined at the beginning of this manual. Failure to do so will cause electric shock and bodily injury or death.
- Familiarize yourself with the location of the circuit breaker. Be sure that a circuit breaker or some other emergency power cutoff device is in place before any power wiring is done to the system. Failure to do so will cause bodily injury or death.
- ⚡ Never touch any power lines or live cables before all power is cutoff to the system. To do so will cause bodily injury or death.
- Undersized wiring will lead to unacceptable voltage at the unit and will cause a fire, which will cause bodily injury or death.
- Properly ground the Single Zone outdoor and indoor units. Ground wiring is required to prevent accidental electrical shock, bodily injury, and death during current leakage.
- Ground wiring must always be installed by a trained technician.
- Install appropriately sized breakers / fuses / overcurrent protection switches and wiring in accordance with local, state, and NEC regulations related to electrical equipment and wiring, and following the instructions in this manual. Using an oversized breaker or fuse will result in electric shock, physical injury or death.
- ⚡ Do not connect ground wire to refrigerant, gas, or water piping; to lightning rods; to telephone ground wiring; or to the building plumbing system. Failure to properly provide a NEC-approved earth ground can result in electric shock, fire, physical injury or death.

⚠ NOTE

- Consider ambient conditions (temperature, direct sunlight, inclement weather, etc.) when selecting, installing, and connecting the power wiring.
- Properly ground the Single Zone outdoor and indoor unit. Improperly connected ground wire can cause communication problems from electrical noise and motor current leakage. Ground wiring must always be installed by a trained technician.
- Install appropriately sized breakers / fuses / overcurrent protection switches and wiring in accordance with local, state, and NEC regulations related to electrical equipment and wiring, and following the instructions in this manual. Using an oversized breaker or fuse will result in equipment malfunction and property damage.
- ⚡ Do not connect ground wire to refrigerant, gas, or water piping; to lightning rods; to telephone ground wiring; or to the building plumbing system. Failure to properly provide a NEC-approved earth ground can result in property damage and equipment malfunction.
- ⚡ Do not operate the air conditioning system until the refrigerant piping installation is complete. Operating the system before refrigerant piping is finalized will damage the compressor.

Power Wiring / Communication Cable Connections

Best practice dictates using solderless ring or fork terminals at all power wiring and communication cable terminations. Use copper bearing ring or fork terminals; ⚡ do not use galvanized or nickel plate over steel. Use appropriate crimping tool to attach the ring or fork terminals at all power wiring and control cable terminations.

To Install a Ring or Fork Terminal:

1. Trim the wiring with wire cutters or pliers, then strip the insulation to expose the strand wiring to about 3/8 inches.
2. Using a ring terminal fastener or pliers, securely clamp a ring terminal to each stripped wire end.

Figure 54: Close up of a Typical Ring Terminal.

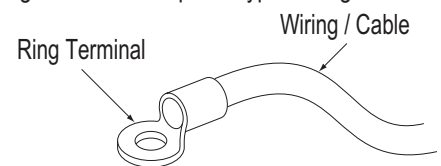
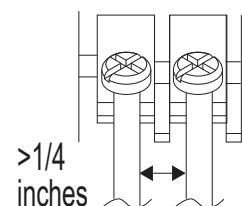

Figure 55: Distance Between the Terminal Connections.



ELECTRICAL SYSTEM INSTALLATION

Connections and Specifications

Power Wiring / Communication Cable Connections, continued

To Connect the Wiring to the Terminals:

1. Remove the JIS terminal screws from the (outdoor unit or indoor unit) terminal plate with a JIS screwdriver. (See information about LG terminal connections below.)
2. Position the ring terminal around the terminal, place the terminal screw in the ring, and tighten to the terminal plate using a JIS screwdriver.
 - Firmly attach the wire; secure in a way to prevent external forces from being imparted to the terminal block.
 - Use an appropriately sized JIS screwdriver for tightening the terminals.
 - ⚠ Do not over tighten the connections; over tightening will damage the terminals.

Figure 56: Adding a Ring Terminal to the Wiring.

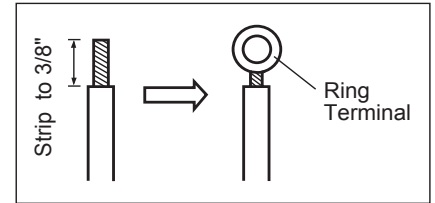

If ring terminals or fork terminals are not available, then:

- ⚠ Do not terminate different gauge wires to the power terminal block. (Slack in the wiring will generate heat.)
- When terminating wires of the same thickness, follow the instructions demonstrated in the figures below.

Figure 57: Tightening the Ring Terminal to the Terminal Plate.

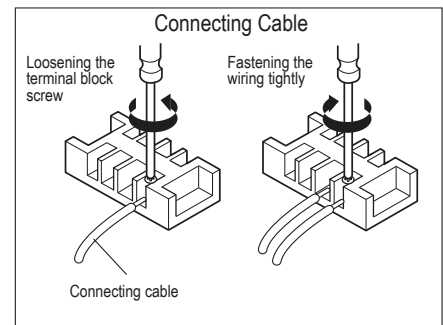

⚠ WARNING

If power wires are not properly terminated and firmly attached, there is risk of fire, electric shock, and physical injury or death.

⚠ NOTE

- ⚠ Never apply line voltage power to the communications cable terminal block. If contact is made, the PCBs will be damaged.
- Always include some allowance in the wiring length when terminating. Firmly attach the wiring or cable, but provide some slack to facilitate removing the electrical panels while servicing, and to prevent external forces from damaging the terminal block.

Figure 58: Proper and Improper Power Wiring Connections.

● :Copper Wire

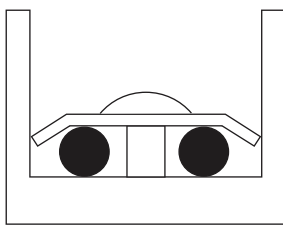

Terminate multiple power wires of the same gauge to both sides.

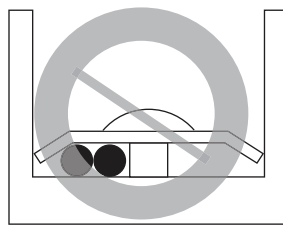

⚠ Do not terminate two wires of one side.

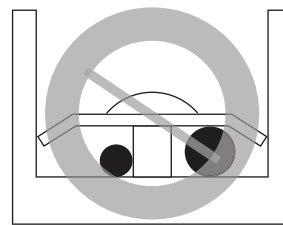

⚠ Do not terminate different gauge wires to a terminal block.

Terminal Connections

LG uses a "JIS" type of screw for all terminals; use a JIS screwdriver to tighten and loosen these screws and ⚠ avoid damaging the terminal. ⚠ Do not over tighten the connections — over tightening will damage the terminals — but firmly and securely attach the wiring in a way to prevent external forces from being imparted to the terminal block.

Note:

- The terminals labeled "GND" are NOT ground terminals. The terminals labeled ⚡ ARE ground terminals.
- Polarity matters. Always connect "A / 1" to "A / 1" and "B / 2" to "B / 2."
- ⚠ Do not include splices or wire nuts in the communication cable.

Figure 59: JIS Screws.

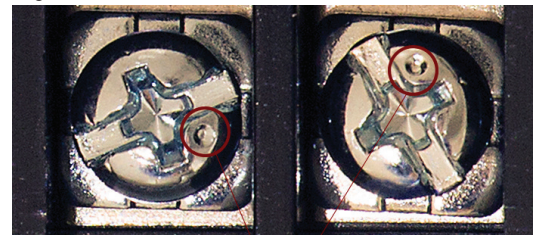

JIS DIMPLES

ELECTRICAL SYSTEM INSTALLATION

Connections and Specifications

Power Supply / Power Wiring Specifications

- Mid-static ducted systems operate at 1Ø, 208-230V, 60Hz.
- Power wiring / power wiring gauge to the outdoor unit(s) must be solid or stranded, and must comply with all National Electrical Code (NEC), UL, and local electrical codes.
- The indoor unit is powered by the outdoor unit.
- Power supply, wire types and sizes, and circuit breaker must be selected based on NEC, UL, and local codes. Maximum allowable voltage fluctuation $\pm 10\%$ or nameplate rated value.
- Properly ground the outdoor unit and indoor unit per NEC, UL, and local codes.
- Ground wire must be longer than the common power / communication wires.
- Connect the wiring firmly so the wires cannot be easily pulled out.
- Refer to the inside of the chassis cover or control cover for circuit and terminal block diagrams.
- Always match color codes of each wire and follow wiring diagram.
- Ⓞ Do not install power wiring to the outdoor unit and the communication / connection (power) cable from the outdoor unit to the indoor unit in the same conduit. Use separate conduits.

Figure 60: Single Zone Outdoor Unit Power Wiring Diagram.

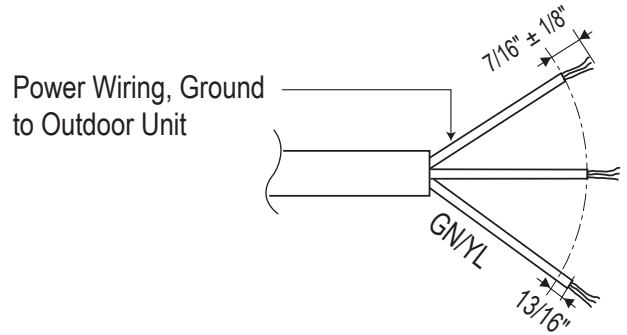

Figure 61: Power Wiring Conduit.



⚠ DANGER

Refer to *Electrical Data* table for ampere ratings. Properly size all circuit breakers / fuses, wiring and field provided components per local codes. There is risk of fire, electric shock, explosion, physical injury or death.

⚠ WARNING

- All power wiring installation must be performed by trained service providers working in accordance with local, state, and NEC regulations related to electrical equipment and wiring, and following the instructions in this manual. Failure to do so will lead to electric shock and bodily injury or death.
- Use specified wiring for connections, and ensure that external force is not imparted to terminal connections. It will generate heat and / or cause a fire, resulting in physical injury or death.
- Use heat-proof electrical wire capable of withstanding temperatures up to 167°F to avoid wiring malfunction and electrical shock, which will cause physical injury or death.
- Install appropriately sized breakers / fuses / overcurrent protection switches and wiring in accordance with local, state, and NEC regulation related to electrical equipment and wiring, and following the instructions in this manual. Generated overcurrent will include some amount of direct current. Using an oversized breaker or fuse will result in electric shock, physical injury or death.
- Use the appropriate type of overcurrent protection. Generated overcurrent will include some amount of direct current, and if the appropriate type of overcurrent protection is not installed, there is a risk of fire, electric shock, and physical injury or death.
- Ground wiring is required to prevent accidental electrical shock during current leakage, communication problems from electrical noise, and motor current leakage. Ⓞ Do not connect the ground line to the pipes. There is risk of fire, electric shock, explosion, physical injury or death.
- Per code, install a main indoor breaker, and an outdoor service disconnect that interrupts all power sources simultaneously. There is risk of fire, electric shock, explosion, physical injury or death.

⚠ NOTE

- If there is a possibility of momentary blackout, or the power goes on and off while the system is operating, install a field-supplied phase loss protection circuit. If not, the compressor and other components will be damaged.
- Use heat-proof electrical wire capable of withstanding temperatures up to 167°F to avoid damage to unit.
- Install appropriately sized breakers / fuses / overcurrent protection switches and wiring in accordance with local, state, and NEC regulations related to electrical equipment and wiring, and following the instructions in this manual. Generated overcurrent will include some amount of direct current. Using an oversized breaker or fuse will result in equipment malfunction and property damage.
- Ⓞ Do not connect ground wire to refrigerant, gas, or water piping; to lightning rods; to telephone ground wiring; or to the building plumbing system. Failure to properly provide a NEC approved earth ground can result in property damage and equipment malfunction.

ELECTRICAL SYSTEM INSTALLATION

Connections and Specifications

Communication / Connection (Power) Cable Specifications from Outdoor Unit to Indoor Unit

- Communication / connection (power) cable from the single zone outdoor unit to the indoor unit must use a minimum of 14 AWG, four (4) conductor, stranded, shielded or unshielded (if shielded, it must be grounded to the chassis of the outdoor unit only), and must comply with applicable local and national codes.
- Use of 14 AWG, four (4) conductor, stranded, shielded or unshielded wire is allowed for lengths up to the published maximum pipe length, plus recommended slack at both ends.
- Insulation material as required by local code.
- Firmly attach the cable; provide slack but secure in a way to prevent external forces from being imparted on the terminal block.
- Wiring must be completed without splices.

Figure 62: Single Zone Outdoor Unit to Indoor Unit Wiring and Communications Cable Diagram.

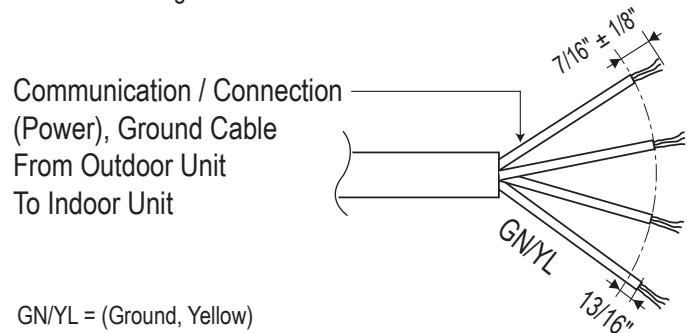

GN/YL = (Ground, Yellow)

⚠ WARNING

All power wiring and communication cable installation must be performed by trained service providers working in accordance with local, state, and National Electrical Code (NEC) / UL / ETL federal regulations related to electrical equipment and wiring, and following the manufacturer product diagrams, requirements, and instructions in this manual. Failure to do so will lead to electric shock which can cause physical injury or death.

Note:

- Always verify the communication cable is connected to a communications terminal on the Single Zone unit. ⚡ Never apply line voltage power to the communication cable connection. If contact is made, the PCBs will be damaged.
- The shield of the communications cable connecting the outdoor unit to the indoor unit must be grounded only to the outdoor unit frame.
- Tie the shield of each cable segment together using a wire nut at the indoor unit. Maintain polarity throughout the communication network.
- Position the incoming power to the outdoor unit away from the power / communications cables from the outdoor unit to the indoor unit.
- ⚡ Never use a common multiple-core communications cable.

Figure 63: Single Zone Mid-Static Power / Communication System Diagram (Appearances May Vary Slightly).

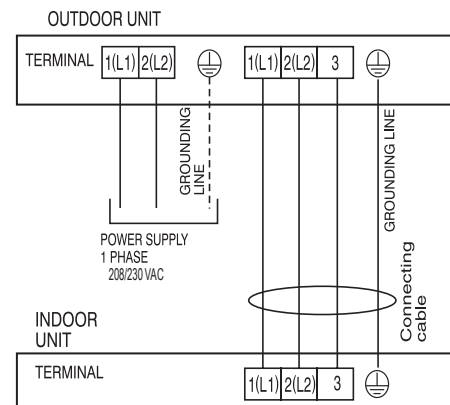

Note:

- Use a conduit for the communications cable / power wiring from the outdoor unit to the indoor units.
- Make sure the communications cable / power wiring from the outdoor unit to the indoor unit, and the power wiring to the outdoor unit are separate, otherwise, the outdoor unit operation will be affected by electrical noise and will malfunction or fail.

ELECTRICAL SYSTEM INSTALLATION

Wired Controller Connections

Wired Controller Connections

Optional controllers (sold separately; see “Functions, Controls, Options” in the engineering manual, or contact an LG representative for more information) can connect to the Mid-Static Ducted indoor unit in one of two different ways.

1. LG Wired Remote Extension Cable with Molex plug (PZCWRC1; sold separately) that connects to the CN-REMO terminal on the indoor unit PCB.
2. Field-supplied controller cable that connects to the indoor unit terminal block (must be at least UL2547 or UL1007, and at least FT-6 rated if local electric and building codes require plenum cable usage). Communication cable from indoor unit to remote controller is to be 22 AWG, 3-conductor, twisted, stranded, unshielded. Wiring must comply with all applicable local and national codes.

Note:

- When using field-supplied controller cable, make sure to connect the yellow to yellow (communications wire), red to red (12V power wire), and black to black (ground wire) terminals from the remote controller to the indoor unit terminal blocks.
- Use extension cable if the distance between wired remote controller and the indoor unit is >32 feet (9.75 m).

Wired Controller Installation Location

Mid-static ducted indoor units can be used with various wired controllers (optional; sold separately). Wired controllers include a sensor to detect room temperature. To maintain comfort levels in the conditioned space, the wired controller must be installed in a location away from direct sunlight, high humidity, and where it could be directly exposed to cold air. Controller must be installed four (4) to five (5) feet above the floor where its display can be read easily, in an area with good air circulation, and where it can detect an average room temperature.

Note:

⊘ Do not install the remote controller where it can be impacted by the following:

- Drafts or dead spots behind doors and in corners
- Hot or cold air from ducts
- Radiant heat from sun or appliances
- Concealed pipes and chimneys
- Uncontrolled areas such as an outside wall behind the remote controller

1. Pull communications cable between the controller handy box (if used) and the indoor unit (field supplied; see submittals for communication cable specifications).
2. Store a minimal amount of cable in the handy box. Any additional cable must be coiled and stored near the indoor unit control panel.
3. If the cable between a zone controller and the indoor unit is too long, ⊘ do not cut. Coil any spare communications cable, tie-wrap it, and leave it next to the indoor unit location.

Assigning the Thermistor for Temperature Detection

Each indoor unit includes a return air thermistor assigned to sense the temperature. If a wired controller is installed, there is a choice of sensing temperature with either the indoor unit return air thermistor or the thermistor in the wired controller. It is also an option to set both thermistors to sense temperature so that indoor unit bases its operation on the first thermistor to reach the designated temperature differential.

Figure 64: Wired Controller Connection.

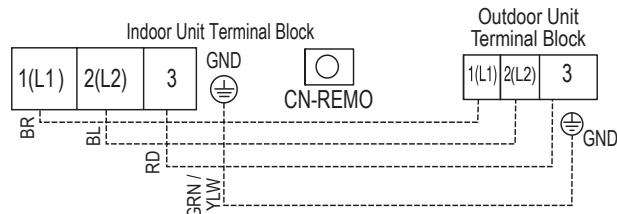

Figure 65: PZCWRC1 LG Wired Remote Extension Cable.

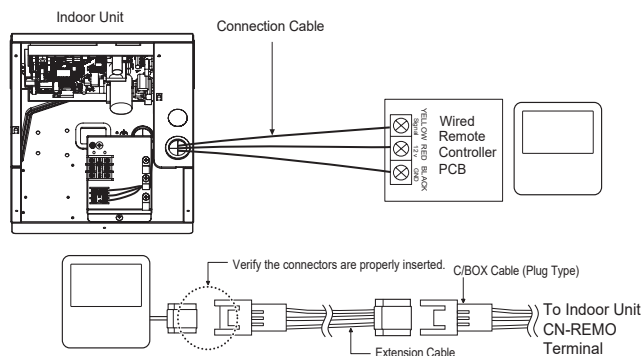
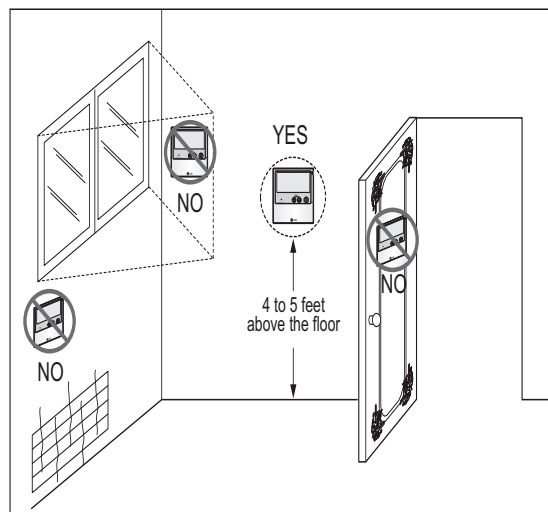

Figure 66: Wired Controller Installation Location.



ELECTRICAL SYSTEM INSTALLATION

Wired Controller Connections

Wired Controller Installation

⚠ WARNING

- Always have power off before installing the controller.
- ⓧ Never operate the indoor unit or outdoor unit outside of the operational parameters as outlined in this manual and the product specifications.
- ⓧ Never touch wiring or install accessories with wet hands.
- When drilling holes for the communication cable and the screws, take care not to damage wiring that is routed through the wall. There is risk of fire, electric shock, explosion, and physical injury or death.

Note:

The controller is designed to be surface mounted. Recessing the controller will damage the temperature sensor, and cause it to misread the zone temperature.

1. If not already done, separate the controller from its installation plate.
- To separate, insert a small screwdriver into one of the two holes at the bottom of the installation plate. Gently turn clockwise.
 - Repeat for the remaining hole, and then gently pull outward on the bottom of the controller body.

Figure 67: Removing the Controller from the Installation Plate.

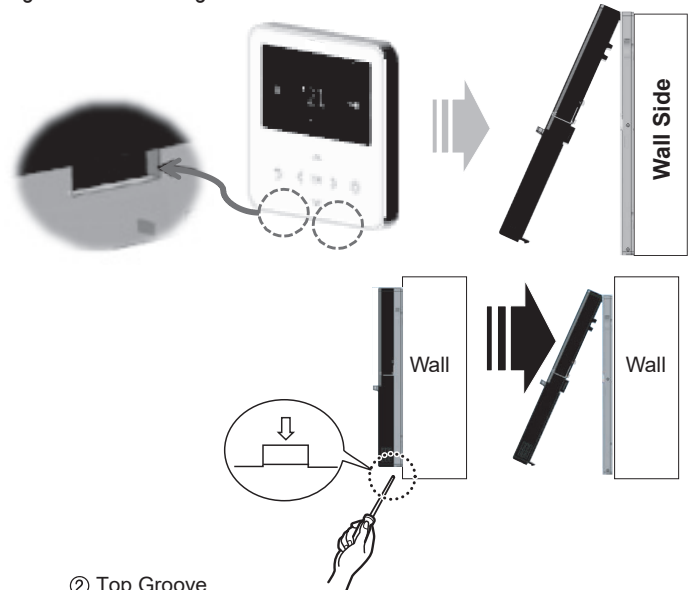

⚠ WARNING

ⓧ Do not damage the controller components when separating. There is risk of fire, electric shock, and physical injury or death if the electrical components are damaged.

2. Determine how the communications cable (female end) will be routed to the controller. Choose either through the back, using the top groove, using the left groove, or using right groove.

Figure 68: Routing the Communications Cable.

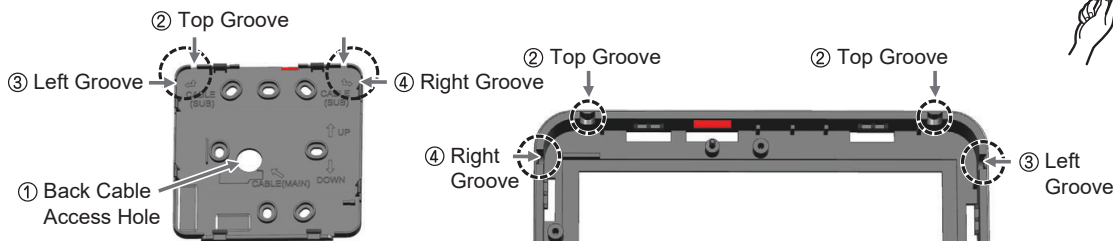

- If using the top, left, or right groove, use needle nose pliers to carefully break off the guide tab. Trim area neatly.
- If using the left groove:
 - Bend the cable to an "L" shape as shown.
 - Insert the cable into the top of the controller. Attach at center.
 - After wiring is complete, carefully tighten the controller to installation plate to avoid damaging components.

Figure 69: Left Groove Installation, Preparing and Inserting the Cable Properly.



Example Proper Shape of the Bent Cable

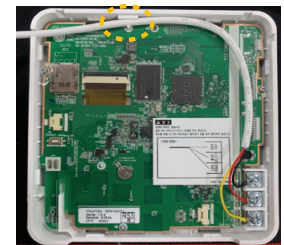

Location at Top for Attaching the Cable

Note:

If the cable is not bent and inserted properly, it may not fit the installation plate / inside the controller.

ELECTRICAL SYSTEM INSTALLATION

Wired Controller Connections

Wired Controller Installation, continued.

- If using the back, route the communications cable through the handy box or wall, and through the large hole in the installation plate.

Note:

- If the distance between the controller and the indoor unit is more than 32 feet (9.75 m), use an LG Extension Cable (sold separately).
- Do not install a cable longer than 164 feet (50 m). Communication errors will occur.
- Ensure the cable connections are male to female. If the communications cable is not routed properly with the connections facing the right direction, connections cannot be made.
- Install a totally enclosed, noncombustible conduit if local, state, or federal building codes require it for plenum cable use.

3. Attach the controller installation plate to the wall or handy box using the factory-provided screws. Ensure the plate is level and securely attached to the wall.

Note:

- Do not overtighten the screws and bend the installation plate. It damages the controller PCB.
- Ensure the installation plate fits into the handy box, if applicable.

4. Seal all gaps or holes behind the installation plate before mounting. If mounting the controller over a handy box, seal the holes in the handy box using spray foam or similar insulation material approved by all applicable codes.

5. Attach the top of the controller to the top of the installation plate. Verify that the controller is level and secure, and there are no gaps.

6. Plug the male connection on the controller into the female end of the communications cable.

7. Connect the controller cable to terminal CN-REMO on the indoor unit PCB.

8. Guide the bottom of the controller to the bottom of the installation plate. Gently push on the controller along the bottom edge until it snaps onto the plate. Verify that it is properly seated with no gaps between the controller and the installation plate.

Figure 70: Location of the Controller Installation Plate Screws When Using a Handy Box.



Figure 71: Attaching the Top of the Controller to the Installation Plate.

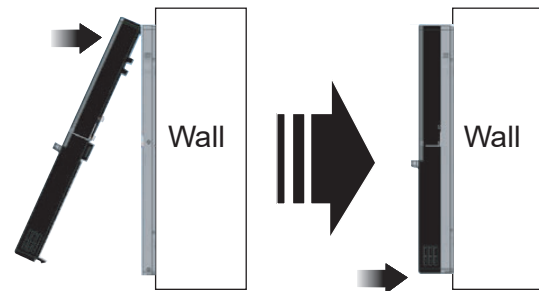
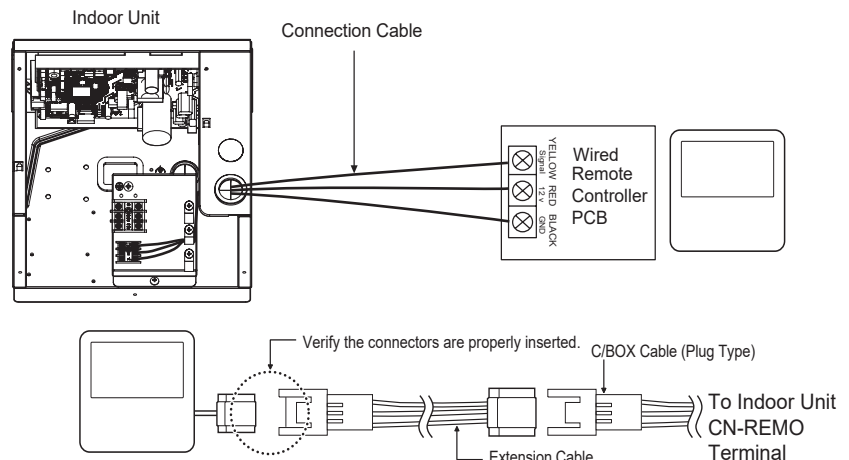

Figure 72: Controller Communication Cable Termination.



ELECTRICAL SYSTEM INSTALLATION

Indoor Unit Electrical Connections

Connecting Indoor Unit Wiring

⚠ WARNING

- Verify that main power to the unit is completely off before proceeding with these steps as there is a risk of electrical shock, bodily injury, and / or death.
- Each wire must be tightly attached to the terminal block. Loose wiring connections cause the terminal to overheat, resulting in fire, electrical shock, bodily injury, and / or death.
- Follow all safety and warning information outlined at the beginning and throughout this manual. Failure to do so will cause electrical shock, bodily injury, and / or death.

Note:

- Follow all safety and warning information outlined at the beginning and throughout this manual. Failure to do so will cause unit failure.
- Connect the communication / connection (power) cable to the indoor unit by matching the terminals on the outdoor unit control board. Verify the color of the wires at the outdoor unit, along with the terminal numbers, match those for the indoor unit.
- Images are representative; actual appearance will vary.
- Refer to the circuit diagram on the indoor unit.

1. Using a Phillips head screwdriver, remove the metal control box cover (one panel) by unscrewing the two (2) screws that hold it in place. Set aside the metal control box cover and screws for reattachment.
2. Insert the communication / connection (power) cable (from the outdoor unit to the indoor unit) through the designated access hole in the side of the ducted frame (see images). If using a conduit, attach it to the conduit hole, and secure with a lock nut.
3. Attach the communication / connection (power) cable to the inside of the frame with the clamp.
4. Using a JIS screwdriver, connect the cable terminals to the terminal block. Ensure wire color and terminal number of the indoor unit matches those of the outdoor unit. Refer to the wiring diagram on the indoor unit.
5. When installing the wired remote controller (sold separately), insert the controller wiring through its designated access hole below the communication / connection (power) cable. Refer to the wiring diagram on the indoor unit. Using a JIS screwdriver, attached that cable to the appropriate terminal block connection.
6. Reinstall the metal control box by reattaching it with its two (2) screws.

Figure 73: Removing the Control Box.

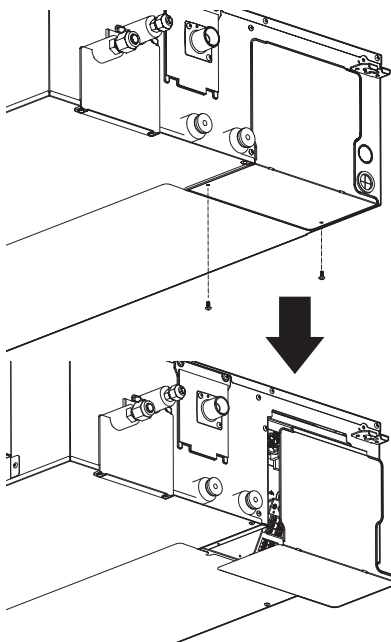

Figure 74: Location of the Access Holes.

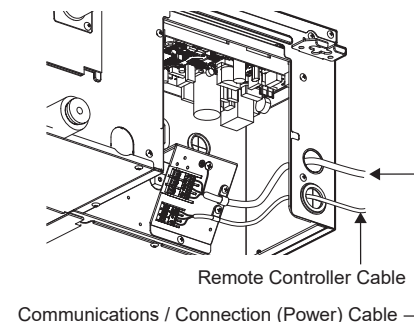
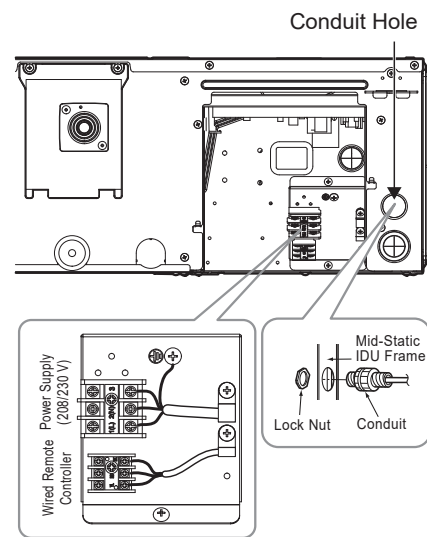

Figure 75: Using a Conduit.



Note:

- Each wire must be securely attached to the terminal block.
- Ground cable must be longer than the other wires.
- Secure the cable onto the control board using a cable tie.
- Use a conduit to protect the cable / refrigerant piping from the indoor unit to the outdoor unit. For more information on conduits or the bundling method, see the Refrigerant Piping Connection section.

ELECTRICAL SYSTEM INSTALLATION

Vertical Installation Conversion Kit Wiring / Using a Conduit

Mid-Static Ducted Vertical Installation Conversion Kit Wiring

⚠ DANGER

When installing / replacing / servicing, wear anti-static gloves to prevent static electricity. Fire and electrical shock can cause physical injury or death.

If the vertical installation conversion kit has been installed on the mid-static ducted indoor unit, additional electrical work is required. See the previous page.

Step 1.

Open the control box cover. Disconnect the wires on CN_D_PUMP and CN_FLOAT on the mid-static ducted indoor unit PCB.

Step 2.

Connect terminals for CN_D_PUMP (white) and CN_FLOAT (blue) (factory-provided accessories included with the conversion kit) as shown in the image at right.

Step 3.

Coil up and tie any extra wiring and close control box cover.

⚠ DANGER

When installing / replacing / servicing, wear anti-static gloves to prevent static electricity. Fire and electrical shock can cause physical injury or death.

Using a Conduit for Indoor Unit Wiring / Cable Installation

Note:

Use a liquidtight 3/4 inch elbow connector for flexible conduit to protect the communication / connection (power) cable.

1. Assemble the conduit with a grommet and washer (field-supplied separately or included with the elbow connector).
2. Guide the power wiring / communication cable into the conduit assembly..
3. Attach the conduit assembly to the indoor unit with a lock nut.

Note:

Check local, state, and federal codes when choosing a conduit size.

4. To protect the piping, condensate drain, and conduit from the elements, add a lineset cover from the indoor access hole to the outdoor unit.

Note:

If a conduit is not used, see pages in the "Refrigerant Piping Connections" for refrigerant piping, condensate drain, power wiring / communication cable bundling information.

Figure 76: Vertical Installation Conversion Kit PCB Connections.

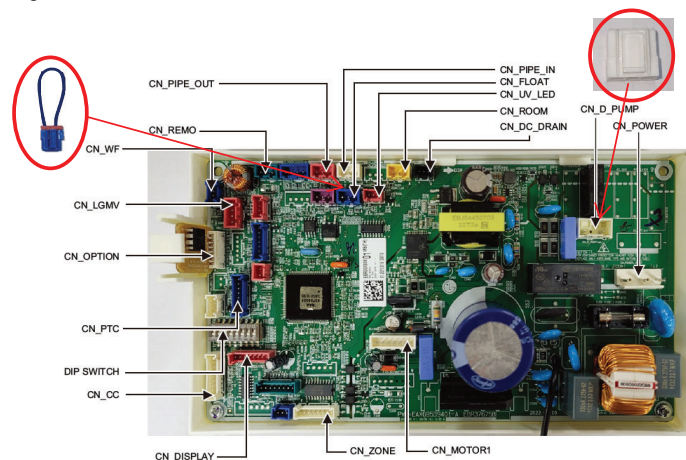
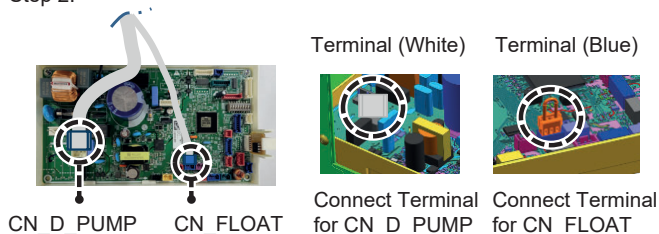

Figure 77: Vertical Installation Conversion Kit Wiring Connection Procedures.

Step 2.



Step 3..

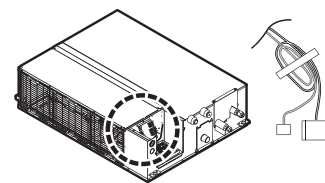

Figure 78: Liquidtight 3/4 Inch Elbow Connector Attached to Flexible Conduit.



ELECTRICAL SYSTEM INSTALLATION

Connecting ODU Wiring

Connecting Outdoor Unit Wiring

⚠ WARNING

- Verify that main power is completely off and that no power is going through the Single Zone system before proceeding with these steps. Follow all safety and warning information outlined at the beginning of this manual. Failure to do so will cause electric shock, bodily injury and / or death.
- Per code, install a main indoor breaker, and an outdoor service disconnect that interrupts all power sources simultaneously. There is risk of fire, electric shock, explosion, physical injury or death.
- Verify that the circuit breaker or some other emergency power cutoff device is in place before any power wiring is done to the system. Failure to do so will cause electric shock, bodily injury and / or death.
- ⚡ Never touch any power lines or live cables before all power is cutoff to the system. To do so will cause bodily injury or death.

1. Using a Phillips head screwdriver, remove the piping / control box cover, side panel and control box cover (depends on model) from the outdoor unit.
2. Inspect all wiring inside the chassis to be sure they are secure and have not loosen during transportation and installation of the outdoor unit. Inspect wires for damage or cracks.

⚠ WARNING

Loose, damaged, or cracked wires will cause electric shock, bodily injury and / or death.

📌 NOTE

Loose wires can cause the wiring to burn out, damaging the outdoor unit.

3. Confirm that electrical power supply capacity will be sufficient to run the unit. Verify that a circuit breaker and service disconnect are installed. See the Electrical table in the Product Data section for details on electrical requirements.

⚠ WARNING

Per code, install a main indoor breaker, and an outdoor service disconnect that interrupts all power sources simultaneously. There is risk of fire, electric shock, explosion, physical injury or death.

4. Confirm that the right gauge size is used for all wiring. Follow all federal, state, and local codes related to wiring.
5. Guide the power wiring to the outdoor unit, and communications / connection (power) cable from the outdoor unit to the indoor unit, through the conduit holes on the outdoor unit or control box cover (see images at right). If using rubber bushings, ensure that they are properly installed, or use conduits to protect the wiring and cable.

Figure 79: Circuit Breaker.

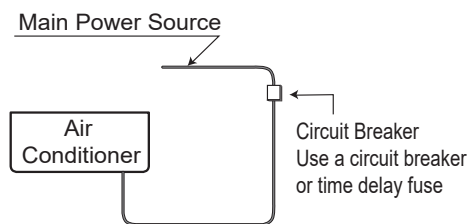

Figure 82: Accessing LUU090-120HV Outdoor Unit Wiring Connections.

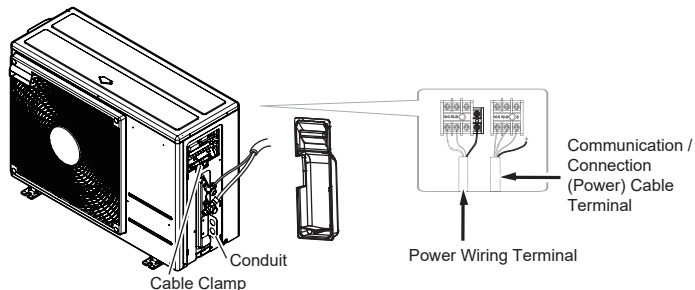

Figure 80: Accessing LUU180-240HV Outdoor Unit Wiring Connections.

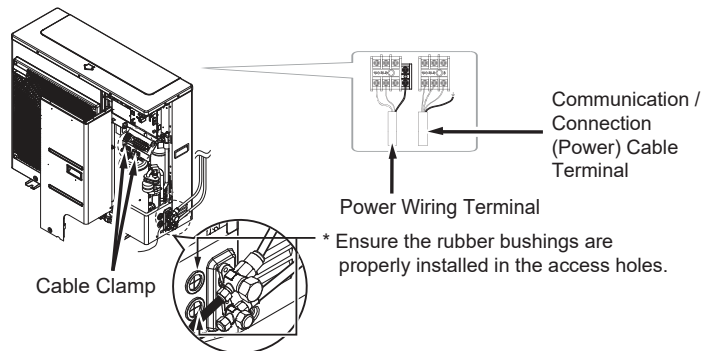

Figure 81: Example of Conduit.



ELECTRICAL SYSTEM INSTALLATION

Connecting ODU Wiring

Connecting Outdoor Unit Wiring, continued.

- Using a JIS screwdriver, connect wires. See also indoor unit wiring diagram, and outdoor unit wiring diagram on the inside of its chassis cover.
 - Each wire must be individually and securely attached to each terminal.

⚠ WARNING

Loose, damaged, or cracked wires will cause electric shock, bodily injury and / or death.

⚠ NOTE

Loose wires can cause the wiring to burn out, damaging the outdoor unit.

- Secure wiring / cables with cable ties.
- Pay attention to the location / connection of the ground cable.
- Maintain a minimum of 1/4 inches of wire length from terminal block to cable bundle.

- When finished, reattach the piping / control box cover or side panel / control box cover (depends on model) to the outdoor unit with the screws.

Note:

⊘ Do not install power wiring to the outdoor unit and the communication / connection (power) cable to the indoor unit in the same conduit. Use separate conduits. Communication problems will occur.

Figure 83: Outdoor Unit Electrical Connections.

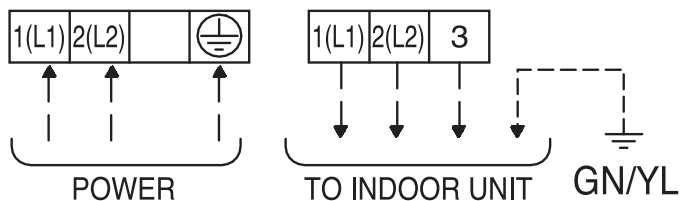

FINAL INSTALLATION PROCEDURES

Triple Leak / Pressure Test

Triple Leak / Pressure Test

After the refrigerant piping installation is complete, perform a triple leak / pressure test. Triple leak / pressure test is performed between the outdoor unit and indoor unit to verify that refrigerant can flow through the system without danger of leaks or pressure losses. Air and moisture that is left in the piping can lead to undesirable results and can cause damage to the system. It is important to go through a complete leak / pressure cycle to be sure that the refrigerant piping is cleared out. This process will have to be repeated if any air or moisture be is found to remain in the piping.

Note:

Insufficient or incorrectly done air purging will lead to the following:

- Pressure in the system can rise.
- Operating current can rise.
- Inefficient cooling or heating mode capability.
- Moisture in the refrigerant circuit will freeze and block capillary tubing.
- Water can lead to corrosion of parts in the system.

⚠ DANGER

Using combustible gases, including oxygen will result in fire or explosion, resulting in personal injury or death. Use inert gas (medical-grade dry nitrogen) when checking leaks, cleaning, installing/repairing pipes, etc. The use of a 800 psig nitrogen regulator is required for safety.

Note:

- ⚠ Never perform the leak test using refrigerant.
- ⚠ To avoid nitrogen entering the refrigerant system in a liquid state, the top of the cylinder must be higher than its bottom (used in a vertical standing position) when the system is pressurized.
- Use only a leak-free gauge manifold set.
- Piping system must not be pressured to more than 550 psi. Pressures greater than 550 psi will damage the piping system and cause unit malfunction.

Triple Leak / Pressure Check Procedure

1. After the refrigerant piping installation is complete, open the isolation ball valves, if any, that may have been included in the piping system.
2. Verify that both the liquid and gas (vapor) suction line outdoor unit service ports are closed, and the stem head access caps are tight. The leak / pressure check is to be performed only to the refrigerant piping system and the connected indoor unit.
3. Remove the cap on the gas (vapor) suction line Schrader port. Connect the (medical-grade dry) nitrogen cylinder regulator to a gauge manifold, then connect the gauge manifold to the gas (vapor) suction Schrader port on the service port.
4. Perform the leak / pressure check at 150 psig for fifteen (15) minutes (standing pressure check).
5. Perform the leak / pressure check at 300 psig for thirty (30) minutes (standing pressure check).
6. Perform the leak / pressure check at 550 psig for one (1) hour to make sure the piping system is leak-free. After the gauge reading reaches 550 psig, isolate the system by first closing the gauge manifold, then close the nitrogen cylinder valve. Check the flared (and any brazed connections) for leaks by applying a bubble solution to all joints.

Note:

The bubble solution must be a solution designed for refrigerant leak testing. Common soap solution must ⚠ never be used on refrigerant piping as those contain chemicals that could corrode copper and brass, and cause product malfunction.

Figure 84: Example of Outdoor Unit Service Valves. (Appearances Will Vary Depending on Model.)

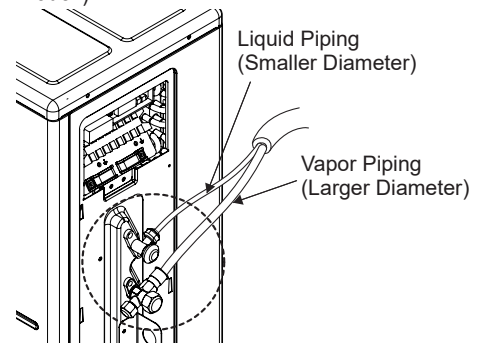
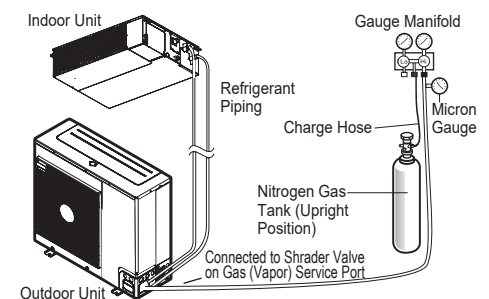

Figure 85: Example of a Triple Leak / Pressure Test Diagram. (Appearances Will Vary Depending on Model.)



FINAL INSTALLATION PROCEDURES

Triple Leak / Pressure and Deep Evacuation Tests

Triple Leak / Pressure Check Procedure, continued.

7. If the pressure does NOT drop for one (1) hour, the system passes the test.
8. If the pressure drops, there is a leak and it must be found. Remove the bubble solution with a clean cloth, repair the leak(s), and perform the leak / pressure check again.
9. After the system has been thoroughly tested and no leaks are found, depressurize by loosening the charging hose connector at the nitrogen cylinder regulator. When system pressure returns to normal, completely disconnect the charging hose from the cylinder, and release the nitrogen charge from all refrigerant piping. Wipe off any remaining bubble solution with a clean cloth.

Deep Evacuation Procedure

After the leak / pressure check is complete, it is required that a deep evacuation procedure is performed to the refrigerant piping and the connected indoor unit. Deep evacuation must be performed through the gas (vapor) suction line Schrader port on the outdoor unit service port.

Note:

The deep evacuation procedure is required for Single Zone systems. A triple evacuation procedure seen on the following pages is a best practices recommendation for Single Zone systems.

Note:

For faster evacuation, the Schrader core can be removed, and an auxiliary service port can be used. Make sure to re-install the original Schrader core before operating the system.

- Deep evacuate through just the gas (vapor) suction Schrader port on the outdoor unit service port.
- The outdoor unit service valves must remain closed and the stem head access caps tight. ⚠ Do not open the outdoor unit service valves and release the factory refrigerant charge until trim charge is complete, and the system is ready to operate.
- Any field-installed ball valves in the refrigerant system (if used) must be open to ensure all piping is free and clear for deep evacuation on all piping and the connected indoor unit.

Note:

- ⚠ Do not apply power to the system before performing the deep evacuation procedure. There is a possibility that the EEV valve will close and isolate sections of the piping system, making the deep evacuation procedure inconclusive.
- ⚠ Never perform evacuation using refrigerant.
- Use only a vacuum pump that can reach 500 microns, vacuum rated hoses or copper tubing, and a leak-free gauge manifold set.
- Use only new vacuum pump oil from a properly sealed (unopened) container, and change oil in pump before EVERY use.
- Subsequent oil changes will be necessary after several hours of continuous operation; have extra oil on hand.
- Use a quality micron gauge in good operating order and install as far away from pump as possible.

Deep Evacuation Procedure Steps

1. If this procedure is performed shortly after the leak / pressure test, the cap and core on the gas (vapor) suction Schrader port must have already been removed, and the manifold must already be connected. If the procedure was not performed shortly after the leak / pressure test, make sure to remove the cap and core on the gas (vapor) suction Schrader port. Verify that the service valves on the outdoor unit are closed, and the stem head access caps are tight.
2. Connect the gauge manifold along with the vacuum pump to the gas (vapor) suction Schrader port (with core removed) using a vacuum hose. Open the gauge manifold and the vacuum pump valves.

Figure 86: Gauge Manifold Hose Connected to the Schrader Valve on the Gas (Vapor) Service Port. (Appearances Will Vary Depending on Model.)

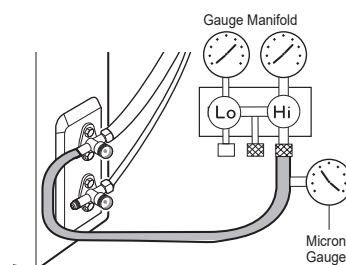

FINAL INSTALLATION PROCEDURES

Deep Evacuation and Triple Evacuation Tests

Deep Evacuation Procedure, continued.

3. Evacuate to static micron level ≤ 500 for at least one (1) hour.
4. Micron level must remain ≤ 500 for two (2) hours. If the vacuum gauge rises and stops, the system may contain moisture; therefore, it will be necessary to repeat the steps of vacuum break and drying.
5. After maintaining the system in vacuum for two (2) hours, check if the vacuum gauge rises or not. If it doesn't rise, then the system is properly evacuated.
6. Close manifold gauges.
7. Shut the valves before turning off and disconnecting the vacuum pump.

Figure 87: Evacuation Procedure Diagram. (Appearances Will Vary Depending on Model.)

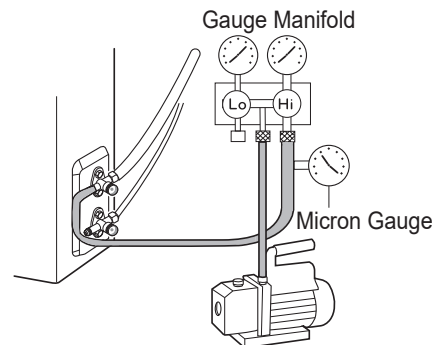

Triple Evacuation Procedure

After the leak / pressure check is complete, it is a best practices recommendation that a triple evacuation procedure is performed to the refrigerant piping and the connected indoor unit. Triple evacuation must be performed through the gas (vapor) suction Schrader port on the outdoor unit service port.

Note:

The deep evacuation procedure is required for Single Zone systems. The triple evacuation procedure is a best practices recommendation for Single Zone systems.

Note:

For faster evacuation, the Schrader core can be removed, and an auxiliary service port can be used. Make sure to re-install the original Schrader core before operating the system.

- Evacuate through just the gas (vapor) suction Schrader port on the outdoor unit service port.
- The outdoor unit service valves must remain closed and the stem head access caps tight. ⚠ Do not open the outdoor unit service valves and release the factory refrigerant charge until trim charge is complete, and the system is ready to operate.
- Any field-installed ball valves in the refrigerant system (if used) must be open to ensure all piping is free and clear for evacuation on all piping and connected indoor unit.

Note:

- ⚠ Never perform evacuation using refrigerant.
- Use only a vacuum pump that can reach 500 microns, vacuum rated hoses or copper tubing, and a leak-free gauge manifold set.
- Use only new vacuum pump oil from a properly sealed (unopened) container, and change oil in pump before EVERY use.
- Subsequent oil changes will be necessary after several hours of continuous operation; have extra oil on hand.
- Use a quality micron gauge in good operating order and install as far away from pump as possible.

FINAL INSTALLATION PROCEDURES

Triple Evacuation Test

Triple Evacuation Procedure Steps

1. If this procedure is performed shortly after the leak / pressure test, the cap and core on the gas (vapor) suction Schrader port must have already been removed, and the manifold must already be connected. If the procedure was not performed shortly after the leak / pressure test, make sure to remove the cap and core on the gas (vapor) suction Schrader port. Verify that the service valves on the outdoor unit are closed, and the stem head access caps are tight.
2. Connect the gauge manifold along with the vacuum pump to the gas (vapor) suction Schrader port (with core removed) using a vacuum hose. Open the gauge manifold and the vacuum pump valves.

Note:

After the vacuum pump is first operated, if hoses, manifold, and vacuum valves are leak free (and oil is not moisture laden), the gauge must read <100 microns within one (1) minute.

⊘ Do not proceed if the gauge does not read <100 microns within one (1) minute. There is a leak in the hose, gauge manifold, or vacuum valve, and the equipment must be replaced.

3. Operate the vacuum pump and evacuate the system to the 2,000 micron level. Isolate the pump by closing the manifold gauges and the vacuum pump valve, and then watch the micron level. Micron level will rise a bit, but MUST eventually stop rising for fifteen (15) minutes.
 - If the micron level DOES NOT stop rising, there is a leak, and the leak test must be performed again.
 - If the micron level DOES rise above 2,000 micron, re-open the manifold gauges and the vacuum pump valve and continue evacuation back down to 2,000 micron level.
 - If the micron level holds at 2,000 micron, continue to step 4.
4. Break vacuum with 50 psig nitrogen purge for an appropriate amount of time (this is to “sweep” moisture from piping).
5. Purge nitrogen from the system until the pressure drops down to 1 to 3 psig.
6. Evacuate to 1,000 micron level. Isolate the pump by closing the manifold gauges and the vacuum pump valve, and then watch the micron level. Micron level will rise a bit, but MUST eventually stop rising for fifteen (15) minutes.
 - If the micron level DOES NOT stop rising, there is a leak, and the leak test must be performed again.
 - If the micron level DOES rise above 1,000 micron, re-open the manifold gauges and the vacuum pump valve, and continue evacuation back down to 1,000 micron level.
 - If the micron level holds at 1,000 micron, continue to step 7.
7. Break vacuum with 50 psig nitrogen purge for an appropriate amount of time.
8. Purge nitrogen from the system until the pressure drops down to 1 to 3 psig.
9. Evacuate to static micron level ≤ 500 for at least one (1) hour.
10. Micron level must remain ≤ 500 for two (2) hours. If the vacuum gauge rises and stops, the system may contain moisture; therefore, it will be necessary to repeat the steps of vacuum break and drying.
11. After maintaining the system in vacuum for two (2) hours, check if the vacuum gauge rises or not. If it doesn't rise, then the system is properly evacuated.
12. Close manifold gauges.
13. Shut the valves before turning off and disconnecting the vacuum pump.

FINAL INSTALLATION PROCEDURES

Refrigerant Trim Charge, Finishing the Job

Refrigerant Trim Charge

The single zone system will need an additional refrigerant charge if the installed piping lengths are greater than the “piping length (no additional refrigerant, ft.) specification” listed in the product tables. See the product sections in the engineering and installation manuals. The system must have the right amount of refrigerant; if the amount of refrigerant level is low, the system will not perform properly. The additional refrigerant charge can be calculated manually using the information in the engineering and / or installation manuals, or by LATS.

1. Keep the outdoor unit service valves closed while adding the trim charge to the system. Charge through the Schrader port. See specification tables in the front of this installation manual for base charge, and see the LATS report for the correct additional refrigerant trim charge amounts for each system.
2. Connect the gauge manifold hose to the gas (vapor) suction Schrader port on the gas service valve.
3. Connect the gauge manifold hose to the refrigerant cylinder. These systems use R410A refrigerant, which must be charged in the liquid state. Verify that the R410A refrigerant cylinder is upside-down.
4. Open both the vapor (gas) and the liquid service valves on the outdoor unit. To open, rotate the valves counter-clockwise by using an Allen wrench.
5. Charge the refrigerant by adjusting the low-pressure valve of the gauge manifold. See the LATS report.
6. After the correct amount of additional refrigerant is charged, close the low-pressure valve of the gauge manifold, and remove the low-pressure hose from the outdoor unit.

Figure 88: Gauge Manifold Hose Connected to the Schrader Valve on the Gas (Vapor) Service Port. (Appearances Will Vary Depending on Model.)

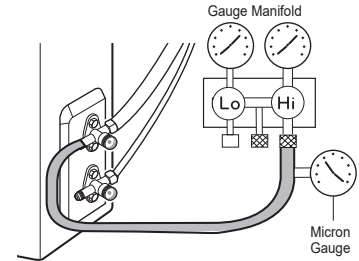
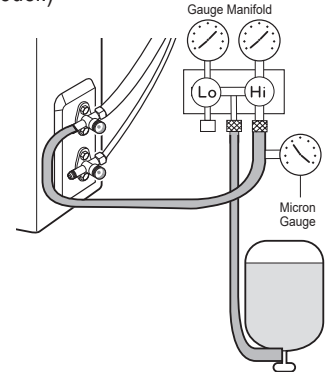

Figure 89: Charging R410A Refrigerant. (Appearances Will Vary Depending on Model.)



⚠ WARNING

- Never inhale or handle refrigerant directly. Doing so will cause bodily injury.
- Follow all local, state, and federal guidelines when handling refrigerant. If all regulations are not followed, it will cause bodily injury.

Refrigerant Line Length Derates

For air-cooled systems, a capacity correction factor will have to be applied to account for the length of the system's refrigerant pipe. Rate of change in capacity due to increased piping lengths is shown below.

Table 25: Convertible Mid-Static Ducted System Cooling and Heating Capacity Coefficient Factors.

Piping Length (ft.)		24.6	32.8	49.2	65.6	98.4	131.2	164.0
Cooling Capacity Coefficient Factor								
Rate of Capacity Change (%)	LH098HV1 (9,000 Btu/h)	100	99.7	99.2	98.7	-	-	-
	LH128HV1 (12,000 Btu/h)	100	99.7	99.2	98.7	-	-	-
	LH188HV1 (18,000 Btu/h)	100	100	99.3	97.9	96.6	93.8	91.1
	LH248HV1 (24,000 Btu/h)	100	100	99.3	97.9	96.6	93.8	91.1
Heating Capacity Coefficient Factor								
Rate of Capacity Change (%)	LH098HV1 (9,000 Btu/h)	100	99.7	99.2	98.7	-	-	-
	LH128HV1 (12,000 Btu/h)	100	99.7	99.2	98.7	-	-	-
	LH188HV1 (18,000 Btu/h)	100	99.3	97.9	96.6	93.8	91.1	88.4
	LH248HV1 (24,000 Btu/h)	100	99.3	97.9	96.6	93.8	91.1	88.4

Note:

- Capacity is based on standard length.
- Equivalent Pipe Length = Actual Pipe Length + Number of Bends x 0.3.
- Additional Refrigerant Charge Calculation : $X (g) = [(Refrigerant\ Pipe\ Length) - (No\ Charge\ Pipe\ Length)] \times (Additional\ Refrigerant)$.
- There is no need to add refrigerant if equivalent pipe is less than the “piping length with no additional refrigerant” in the table above.

FINAL INSTALLATION PROCEDURES

Installer Setting Mode

Installer Setting Mode

Installer Setting Mode sets system functions. Only trained and licensed HVAC technicians should access / use the Installer Setting Mode. If any installation procedure or system change is performed by someone other than a trained and licensed HVAC technician, LG is not responsible for the results, and it will void the warranty.

⚠ WARNING

If the Installer Setting Mode(s) is (are) not set correctly, a system malfunction could cause fire, electrical shock, physical injury and / or death. See the Wired Controller and Central Controller Installation manuals for instructions on entering Installer Mode.

⚠ NOTE

If the Installer Setting Mode(s) is (are) not set correctly, a system malfunction could cause product and / or property damage. See the Wired Controller and Central Controller Installation manuals for instructions on entering Installer Mode.

Installer Setting Modes

Mode Override

Use Mode Override only with non-autochangeover heat pump models.

Group Control

Use for group control.  Do not use this function if the system is not set up for group control.

Note:

After setting Group Control, turn the power OFF, wait for one (1) minute, and then turn the power back on.

Auxiliary Heater

This function is only applicable to systems that have the auxiliary heater installed / activated.

FINAL INSTALLATION PROCEDURES

Setting the External Static Pressure

Setting the External Static Pressure (ESP)

⚠ NOTE

- The ESP must be set by a trained service provider.
- If the ESP is not set correctly, the system will malfunction.

Use the external static pressure setting to determine air flow.

Step 1.

To enter the Installer Setting Mode, press the Up ▲ and Operation Mode (OPER MODE) buttons simultaneously for at least three (3) seconds.

Step 2.

Access the ESP setting mode by pressing the Operation mode (OPER MODE) button and choosing "03".

Step 3.

Select the desired air flow rate by pressing the FAN SPEED button. SLo→Lo→Med→Hi→Po levels will appear. Change to different levels by pressing the FAN SPEED button.

Step 4.

Select the desired air flow rate value using the Temperature Up (▲) and Down (▼) buttons.

- ESP Range: 0 ~ 255
- The ESP value will appear at the upper right hand corner of the display.

Step 5.

Press the On / Off button to save the ESP value for the chosen fan speed.

Step 6.

To release the Installer Setting Mode after all settings are complete, press the Up ▲ and Operation Mode (OPER MODE) buttons simultaneously for at least three (3) seconds. If input isn't performed for more than 25 seconds, the Installer Setting Mode will be released automatically.

Note:

- External static pressure values vary according to the model.
- ⌚ Do not alter the external static pressure value that corresponds to each airflow level.
- When the airflow rate is increased to a higher value, during the external static value setup, the previous airflow value will be stored in the system memory. (External static pressure values are saved to system memory before the changes are implemented).

Figure 90: Using the Buttons on the Controller to Set ESP..

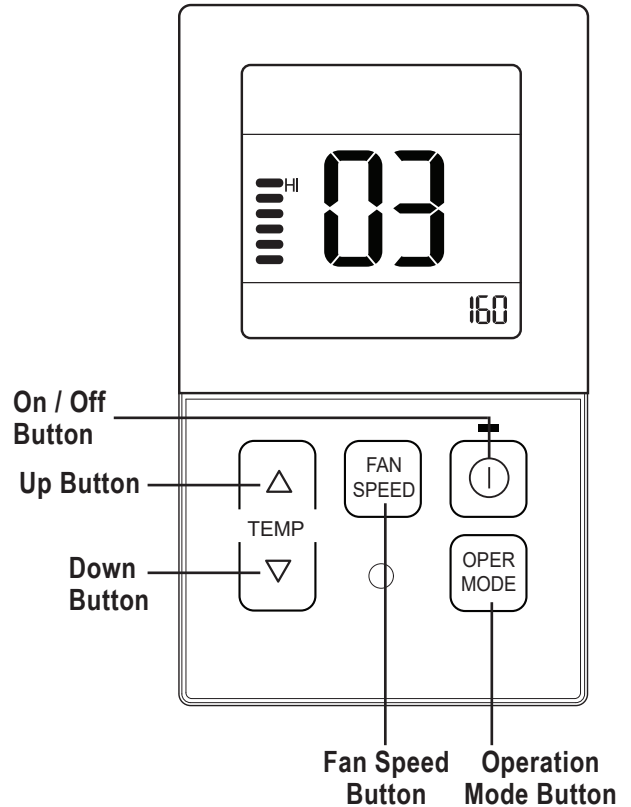

Note:

Consider the final pressure drop if a filter box is installed on the indoor unit. Adjust the air flow rate to compensate for the filter pressure drop.

FINAL INSTALLATION PROCEDURES

Setting the External Static Pressure

Table 26: Mid-Static Ducted Indoor Unit External Static Pressure Setting Values Table.

Static Pressure (in. wg)		0.1	0.16	0.2	0.24	0.28	0.31	0.35	0.39	0.43	0.51	0.59	
Model No. / Nominal Capacity of System (Btu/h)	Airflow Rate / CFM	Setting Value (in. wg)											
		LHN098HV1 9,000	High	353.1	76	88	96	99	104	110	115	121	126
Mid	317.8		72	82	92	95	100	106	111	117	121	131	139
Low	282.5		68	78	88	91	96	102	107	113	117	127	135
LHN128HV1 12,000	High	494.4	91	98	105	108	113	118	122	130	134	143	151
	Mid	423.8	82	92	100	103	108	114	118	126	130	139	147
	Low	353.1	76	88	96	99	104	110	114	121	126	135	143
LHN188HV1 18,000	High	635.7	106	113	117	121	126	128	133	137	139	149	156
	Mid	529.7	94	102	108	109	115	119	122	130	134	145	152
	Low	423.8	82	92	100	103	108	114	118	126	130	139	147
LHN248HV1 24,000	High	706.3	122	128	131	132	136	143	146	148	152	158	164
	Mid	547.4	103	110	114	117	121	127	130	135	138	145	154
	Low	459.1	93	100	105	109	114	118	122	128	131	139	146

Note:

- To get the desired air flow and external static pressure combination, use the setting value from the table. Using a setting value other than that listed in the table will not provide the desired combination.
- Table data is based at 230V. Air flow rate varies according to voltage fluctuation.

FINAL INSTALLATION PROCEDURES

FC-15 / FC-35

FC-15 (Thermo On / Off Differential)

Allows installer setting (field adjustment) of temperature targets. Use FC-15 in applications to overcome the height difference with indoor units installed high on the wall or in the ceiling.

Wired (FC-15) controllers can access the thermo on / off differential. Indoor unit logic must include the function to see the setting codes. If the function is visible, all sub-settings will display, even if the indoor unit logic is limited.

Note:

- Indoor unit logic limits may prevent all sub-settings from being assignable.
- A sub-setting that isn't recognized by the indoor unit will revert to the default setting.
- The controller will display all sub-settings if the function is available for the indoor unit. Contact an LG Representative for details.

FC-35 (Thermo Off - Indoor Unit Fan Off)

Turns off the indoor unit fan during Thermo Off. Requires an LG wired controller to configure / set the installer code.

Table 27: Wired Controller Settings FC-15 Set Codes and Displays.

Function	Code	Setting		Step	Display
		TH On	TH Off		
Optional Heating Thermo On / Off	FC-15	Default		0	15:00
		7°F	11°F	1	15:01
		4°F	7°F	2	15:02
		-2°F	2°F	3	15:03
		-1°F	1°F	4	15:04

Table 28: Wired Controller Settings FC-35 Set Codes and Displays.

Function	Code	Setting	Step	Display
Indoor Unit Fan Off During Thermo Off	FC-35	Indoor Unit Default Airflow (Logic)	0	35:00
		Indoor Unit Fan OFF	1	35:01
		Setting Airflow	2	35:02

FINAL INSTALLATION PROCEDURES

Test Run

Finishing the Job

After the Triple Leak and Evacuation (and refrigerant trim charge, if any) procedures have been performed, follow the steps below to open the refrigerant lines.

1. Verify that the auxiliary service port is removed (if used in the Evacuation procedure) and the original Schrader core was re-installed on the gas (vapor) suction service port.
2. The service ports are a back-seated type with a right hand thread. Remove the service valve caps on both the gas (vapor) suction and the liquid service ports.
3. Using an appropriately sized Allen wrench, fully open the valves on both the gas (vapor) suction and the liquid service ports by turning the valve stem counterclockwise.
4. Turn until the valve stem is out, stops, and the valve is completely backseated. ⚠ Do not apply excessive force.
5. Securely replace service port caps on both the gas (vapor) suction and the liquid using an adjustable wrench.

Test Run

After all installation procedures are complete, the system is ready for a test run. Follow the guidelines below.

1. Verify that the power supply is $\pm 10\%$ of the rated voltage.

⚠ WARNING

All power wiring installation must be performed by trained service providers working in accordance with local, state, and NEC regulations related to electrical equipment and wiring, and following the instructions in this manual. Failure to do so will lead to electric shock and bodily injury or death.

⚠ NOTE

All power wiring installation must be performed by trained service providers working in accordance with local, state, and NEC regulations related to electrical equipment and wiring, and following the instructions in this manual. Failure to do so will lead to property damage and equipment malfunction.

2. Check that all drain piping, refrigerant piping, and wiring / cables are not damaged and are properly connected. Verify the terminals are tight. Check the operation of the remote wired controller. Check if the drain piping and refrigerant piping do not have leaks and are fully and correctly insulated.
3. Check that both the gas (vapor) suction and liquid refrigerant piping service valves are fully open.
4. Turn on the power to the system and the remote wired controller. Switch the system to Test Operation Mode (see Controller Installation Manuals for details).
5. Test the system in cooling operation first, even if installing in heating season.

⚠ WARNING

If the test operation mode runs in heating mode first, the compressor will be damaged, and system malfunction could lead to electric shock, bodily injury, or death.

⚠ NOTE

If the test operation mode runs in heating mode first, the compressor will be damaged, and system malfunction could lead to property and product damage.

6. To cancel the test operation mode, press any button on the wired remote controller.

FINAL INSTALLATION PROCEDURES

Performance Evaluation

Performance Evaluation

1. Allow the system to run (cooling or heating with maximum air flow) for at least five (5) to fifteen (15) minutes. Test operation mode automatically cancels and returns to the factory default setting after eighteen (18) minutes.
2. While the system operates in test operation mode, measure, record, and save any data (room temperature, outdoor temperature, air velocity and volume, piping temperature, condensate drainage, electrical specifications (voltage / current), any abnormal vibration or operating noise). Note any issues that occur.
3. Measure the operating pressure and compressor pressure. Check if the air circulation is adequate, check for refrigerant leaks.
4. Measure the air temperature from both the inlets and outlets of the indoor unit.
5. Verify the difference between the inlet and outlet temperatures is $> 14.4^{\circ}\text{F}$. If it is, the system is functioning normally in cooling.
6. If issues are found, fix as necessary.
7. If no issues are found, cancel the test operation mode. The air conditioner is now ready to use.

Note:

- If all modes can't be tested all at one time, test later when weather conditions permit.
- If the actual pressure is higher than shown, the system is most likely overcharged, and charge must be removed. If the actual pressure is lower than shown, the system is most likely undercharged, and charge must be added.

Figure 91: Performance Evaluation Air Temperature Measurement Locations (For Illustration Purposes Only).

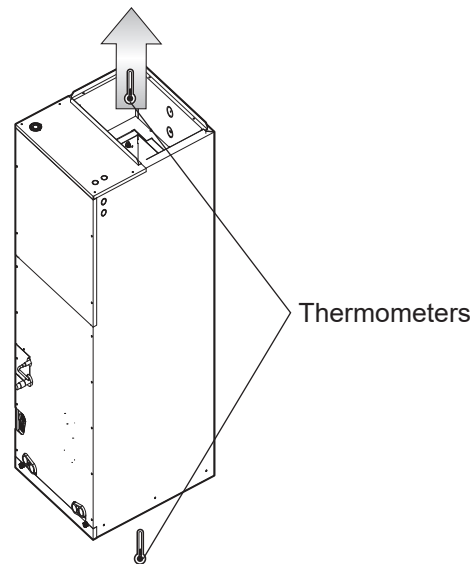

Table 29: Vapor Side Pressure at Optimum Condition When System is in Cooling.

Outside Ambient Temperature	Gas (Vapor) Service Valve Pressure
95°F	120~135 psig

FINAL INSTALLATION PROCEDURES

LHN098-248HV1 Indoor Unit DIP Switch Settings

LHN098-248HV1 Indoor Unit DIP Switch Settings

Indoor units feature optional modes that the service provider sets during installation by using the DIP switches.

Figure 92: Location of DIP Switch Bank on the Indoor Unit PCB.

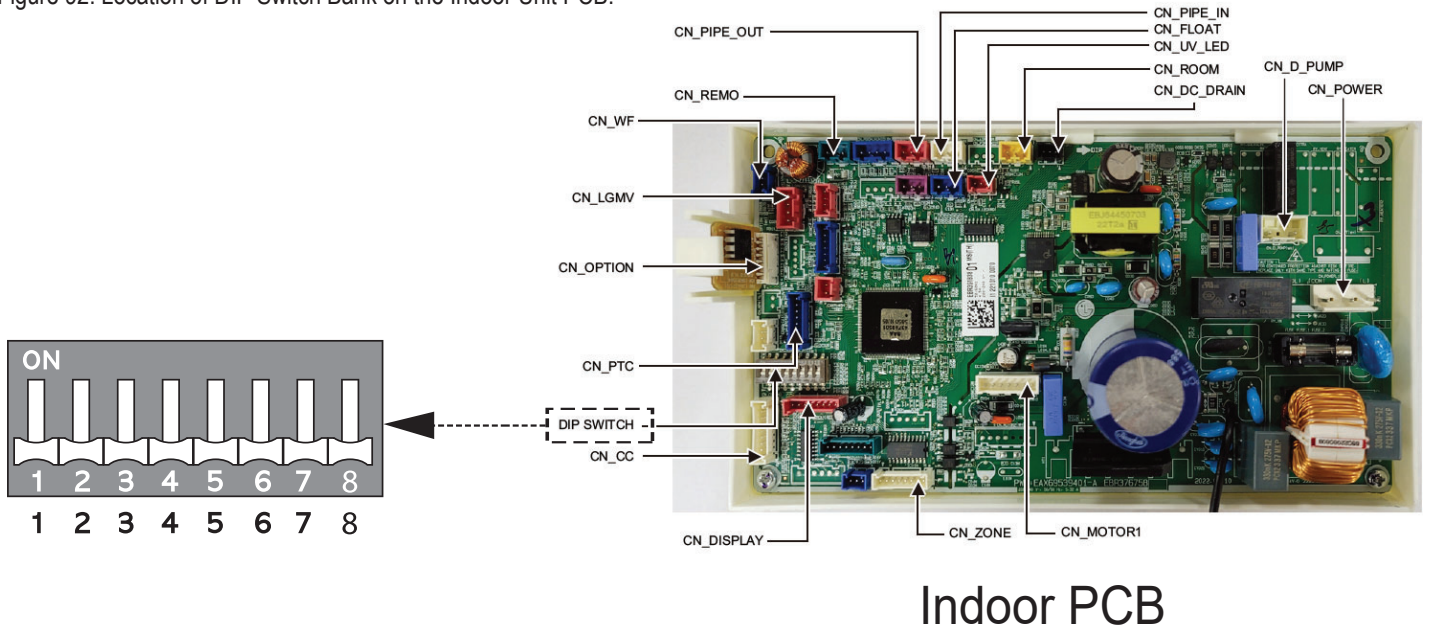

Figure 93: Mid-Static Ducted DIP Switch Settings.

DIP Switch Setting		Off	On	Description
SW3	Group Control	Main	Sub	Group control setting using 7-Day Programmable Controller. Use to select Main / Sub for each indoor unit.
SW4	Dry Contact Mode	Variable	Auto	Sets operation mode for optional Dry Contact accessory 1. Variable: Auto or Manual Mode can be set through 7-Day Programmable Controller or Wireless Remote Controller. 2. Auto: Factory default setting.
SW5	Continuous Fan	Off	On	Selects continuous fan for ducted indoor units. 1. Off: Indoor unit fan speed can turn off and on. 2. On: Indoor unit fan will always operate at a set fan speed, except when the system is off, or the outdoor unit is in defrost mode. When the outdoor unit is in defrost mode, the fan will operate at super low fan speed.

FINAL INSTALLATION PROCEDURES

Setting LUU180-240HV Optional Modes

Setting LUU180-240HV Optional Modes

LUU*** (18 and 24K only) outdoor units feature optional modes that the service provider sets during installation.

⚠ DANGER

Before setting the DIP switches on the PCB for the optional modes, turn the power OFF at the nearest disconnect. Electrical shock can cause physical injury or death.

⚠ WARNING

Only a trained and licensed service should set the DIP switches for the optional modes. The information contained in this manual is intended for use by an industry-qualified, experienced, certified electrician familiar with the U.S. National Electric Code (NEC) who is equipped with the proper tools and test instruments. Failure to carefully read and follow all instructions in this manual can result in personal injury or death.

⚠ NOTE

- The information contained in this manual is intended for use by an industry-qualified, experienced, certified electrician familiar with the U.S. National Electric Code (NEC) who is equipped with the proper tools and test instruments. Failure to carefully read and follow all instructions in this manual can result in equipment malfunction and property damage.
- Optional modes must be properly set with the applicable DIP switches Off or On for each mode. The system will not function properly if the DIP switches are not set properly.
- If the DIP switches are set when the power is ON, the change is not applied. Optional mode changes are only applied when the power is reset.

Location of the Optional Mode DIP Switch Bank on the LUU180HV and LUU240HV Outdoor Units

Figure 94: LUU180HV and LUU240HV Outdoor Unit DIP Switch Bank.

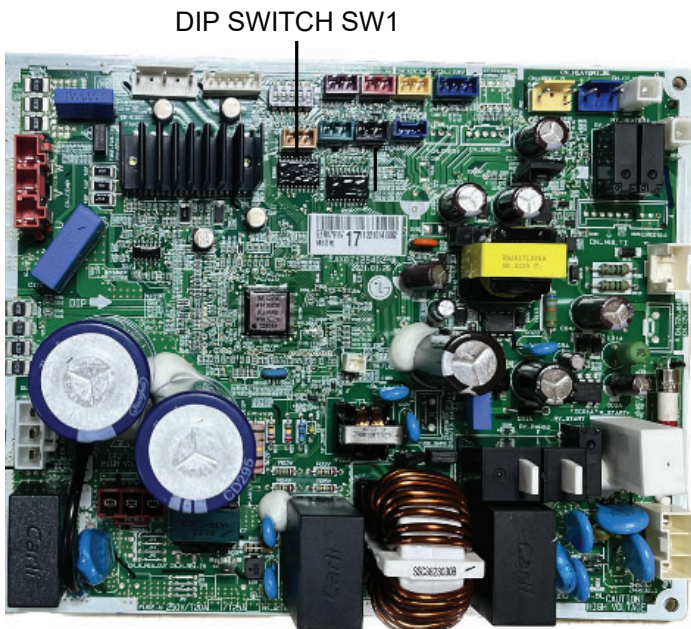

Note:





LUU090HV and LUU120HV outdoor units do NOT include DIP switch banks on the PCBs, therefore, the optional modes listed on the next page are not available for these products.

FINAL INSTALLATION PROCEDURES

Setting LUU180-240HV Optional Modes

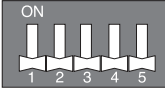
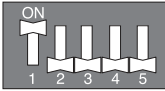
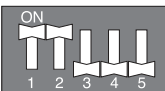
LUU180HV and LUU240HV Optional Modes

Table 30: LUU180HV and LUU240HV Optional Mode DIP Switch Settings.

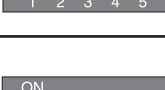
DIP Switches	Function
LUU180HV, LUU240HV	
1 2 3 4 5	
	Normal Operation (No Function)
	Pump Down
	Mode Lock (Cooling)
	Mode Lock (Heating)
	Night Low Sound Level 1 (Maximum Fan 600 rpm, Compressor 60Hz)
	Night Low Sound Level 2 (Maximum Fan 500 rpm, Compressor 50Hz)
	Night Low Sound + Mode Lock (Cooling) Level 1 (Maximum Fan 600 rpm, Compressor 60Hz)
	Night Low Sound + Mode Lock (Cooling) Level 2 (Maximum Fan 500 rpm, Compressor 50Hz)

Single-Zone Convertible Mid-Static Ducted Installation Manual

FINAL INSTALLATION PROCEDURES

Setting LUU180-240HV Optional Modes

LUU180HV and LUU240HV Optional Modes, continued. Pump Down

Use Pump Down mode when adding refrigerant.

1. Shut the power OFF to the system.
2. Remove the control box cover.
3. Set DIP Switch No. 1 to ON according to the system installed as shown.
4. Turn the power ON.
5. The red and green LEDs on the outdoor unit PCB will function as detailed below, indicating the indoor unit is in Pump Down mode.
6. After Pump Down mode is complete, the red LED will turn OFF. If Pump Down is not performing normally, the red LED will blink.

Figure 95: LUU180HV and LUU240HV Pump Down DIP Switch Settings.

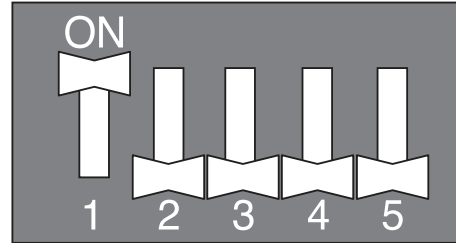

Pump Down Flowchart

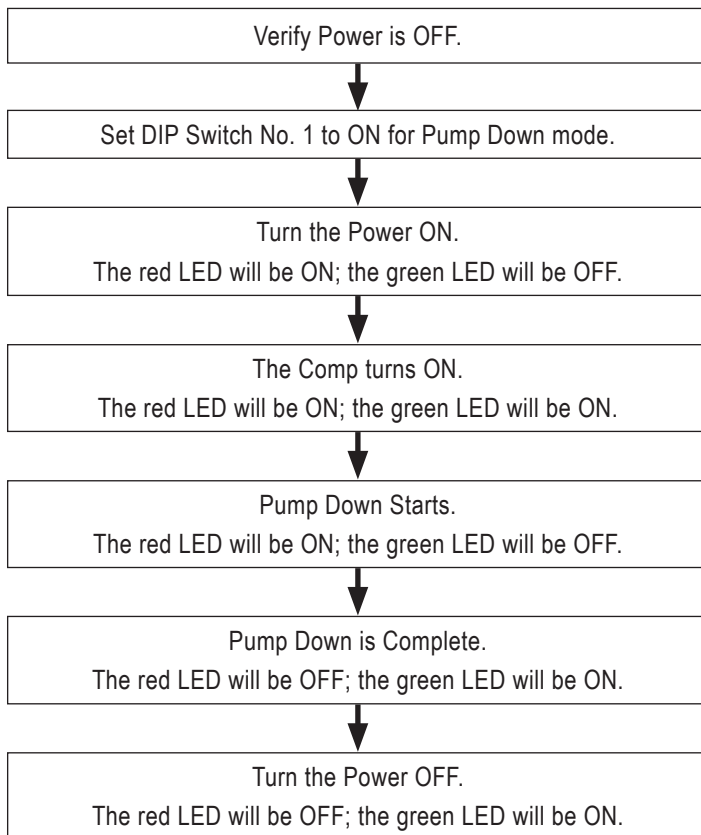

Liquid Valve Closed.

Vapor Valve Closed.

Note:

The liquid valve will close only after the green LED turns OFF (about seven [7] minutes after the system starts). Vapor valve will close after the green LED turns ON.

Note:

- When the green LED is ON, the compressor will be OFF because of system low pressure.
- After Pump Down is finished, ensure the power is OFF, and set DIP Switch No. 1 to OFF for Normal Operation (all DIP switches must be set to OFF for Normal Operation). Turn the power back ON to resume system operation.
- An improper Pump Down procedure will cause the system (along with the red and green LEDs) to shut off within twenty (20) minutes from the initial start.

FINAL INSTALLATION PROCEDURES

Setting LUU180-240HV Optional Modes

LUU180HV and LUU240HV Optional Modes, continued.

Mode Lock (Cooling Only and Heating Only)

1. Shut the power OFF to the system.
2. Remove the control box cover.
3. For Cooling Only Mode Lock, set the DIP Switch Nos. 1 and 2 to ON as shown at right.
4. For Heating Only Mode Lock, set the DIP Switch Nos. 3 and 4 to ON as shown at right.
5. Turn the power ON.

Figure 96: Cooling Only Mode Lock DIP Switch Settings.

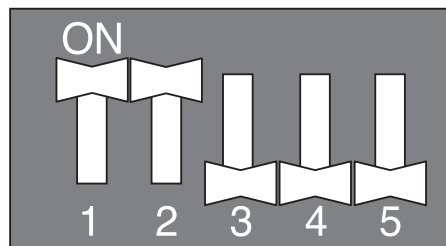
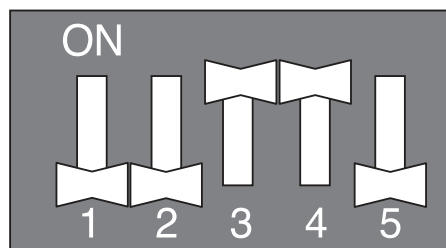

Figure 97: Heating Only Mode Lock DIP Switch Settings.



Night Low Sound

Night Low Sound mode reduces the operation sound of the outdoor unit by changing the compressor frequency and fan speed. Night Low Sound mode operates the entire night.

Choose from Level 1 or Level 2. See the table below.

Table 31: Night Low Sound Levels Specifications.

Outdoor Unit	Standard Operation dBA	Level 1 dBA (Compressor Hz, Max. Fan Speed RPM)	Level 2 dBA (Compressor Hz, Max. Fan Speed RPM)
LUU180HV	48	47 (60, 600)	42 (50, 500)
LUU240HV	48	47 (60, 600)	42 (50, 500)

1. Shut the power OFF to the system.
2. Remove the control box cover.
3. For Level 1, set DIP Switch Nos. 1 and 4 to ON as shown.
OR
For Level 2, set DIP Switch Nos. 2 and 3 to ON as shown.
4. Turn the power ON.

Note:

- If compressor frequency and fan speed are reduced, cooling capacity may also be reduced.
- Night Low Sound mode can only be used with Cooling mode.
- If Night Low Sound mode needs to be stopped, change the DIP switches.
- If indoor unit operation is set by the fan speed "Power", Night Low Sound mode will stop until the fan speed "Power" is changed.

Figure 98: Night Low Sound DIP Switch Settings Level 1.

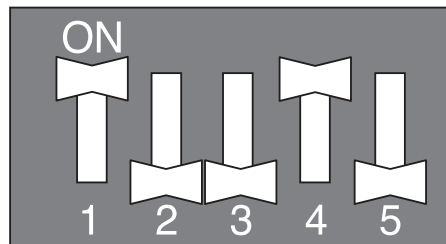
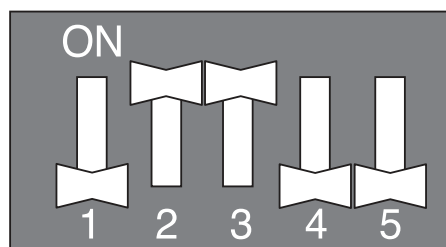

Figure 99: Night Low Sound DIP Switch Settings Level 2.



FINAL INSTALLATION PROCEDURES

Setting LUU180-240HV Optional Modes

LUU180HV and LUU240HV Optional Modes, continued.

Night Low Sound + Mode Lock (Cooling)

This function combines the Night Low Sound function with the Mode Lock function.

Choose from Level 1 or Level 2. See the table below.

Table 32: Night Low Sound Levels Specifications.

Outdoor Unit	Standard Operation dBA	Level 1 dBA (Compressor Hz, Max. Fan Speed RPM)	Level 2 dBA (Compressor Hz, Max. Fan Speed RPM)
LUU180HV	48	47 (60, 600)	42 (50, 500)
LUU240HV	48	47 (60, 600)	42 (50, 500)

1. Shut the power OFF to the system.
2. Remove the control box cover.
3. For Level 1, set DIP Switch Nos. 2 and 4 to ON as shown.
OR
For Level 2, set DIP Switch Nos. 1 and 3 to ON as shown.
4. Turn the power ON.

Note:

- If compressor frequency and fan speed are reduced, cooling capacity may also be reduced.
- Night Low Sound mode can only be used with Cooling mode.
- If Night Low Sound mode needs to be stopped, change the DIP switches.
- If indoor unit operation is set by the fan speed "Power", Night Low Sound mode will stop until the fan speed "Power" is changed.

Figure 100: Night Low Sound with Mode Lock DIP Switch Settings Level 1.

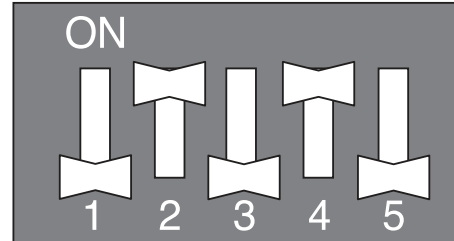
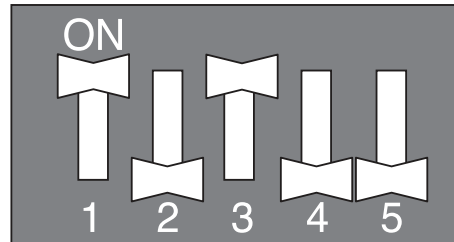

Figure 101: Night Low Sound with Mode Lock DIP Switch Settings Level 2.



FINAL INSTALLATION PROCEDURES

LG Monitoring View (LGMV) Diagnostic Software

LG Monitoring View (LGMV) Diagnostic Software

LGMV software (PRCTSL1 and PRCTFE1) allows the service technician or commissioning agent to connect a computer USB port to the Single Zone unit's main printed circuit board (PCB) using an accessory cable without the need for a separate interface device. The monitoring screen for LGMV allows the user to view the following real time data on one screen:

- Actual inverter compressor speed
- Target inverter compressor speed
- Actual outdoor fan speed
- Target outdoor unit fan speed
- Actual superheat
- Target superheat
- Actual subcooler circuit superheat
- Target subcooler circuit superheat
- Main EEV position
- Subcooling EEV position
- Inverter compressor current transducer value
- Outdoor air temperature
- Actual high pressure/saturation temperature
- Actual low pressure/saturation temperature
- Suction temperature
- Inverter compressor discharge temperature
- Front outdoor coil pipe temperature
- Back outdoor coil pipe temperature
- Liquid line pipe temperature
- Subcooler inlet temperature
- Subcooler outlet temperature
- Average indoor unit (IDU) pipe temperature
- Inverter compressor operation indicator light
- Liquid injection valves' operation indicator lights
- Hot gas bypass valve operation indicator light
- Four-way reversing valve operation indicator light
- Pressure graph showing actual low pressure and high pressure levels
- Error code display
- Operating mode indicator
- Target high pressure
- Target low pressure
- PCB (printed circuit board) version
- Software version
- Installer name
- Model number of IDUs
- Site name
- Total number of connected IDUs

Additional screens can be accessed by tabs on the main screen. Additional screens include the following:

1. Cycleview: Graphic of internal components including:
 - Compressors showing actual speeds
 - EEVs
 - IDUs
 - Temperature and pressure sensors
 - Four-way reversing valve
2. Graph: Full screen graph of actual high and low pressures and high and low pressure limits. A sliding bar enables user to go back in time and view data.
3. Control FTN: Enables user to turn on IDUs in 1.8°F increments.
4. Useful Tab
 - Unit Conversion: Converts metric values to imperial values.

Note:

Images on these pages are examples of LGMV screenshots. Actual images may differ depending on the version of the software and the unit installed.

Figure 102: MV Real-time Data Screen.

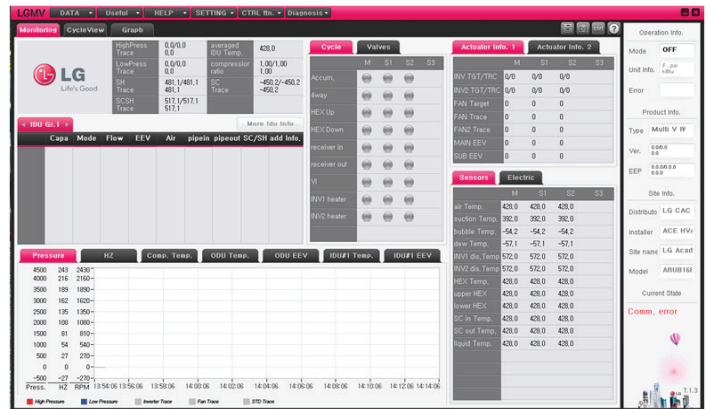

- Communication indicators
- IDU capacity
- IDU operating mode
- IDU fan speed
- IDU EEV position
- IDU room temperature
- IDU inlet pipe temperature
- IDU outlet pipe temperature
- IDU error code

Figure 103: MV Cycleview.

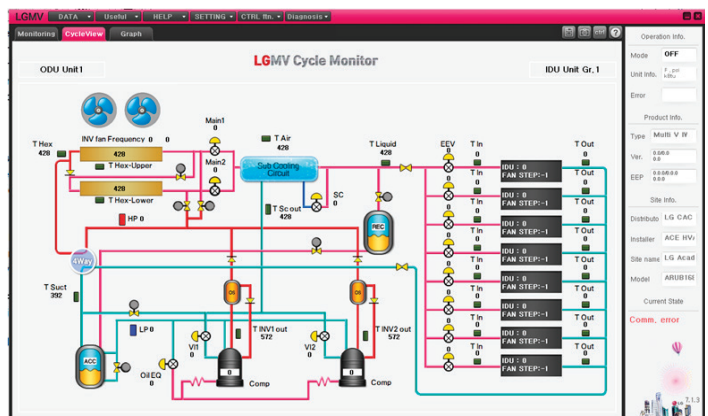

FINAL INSTALLATION PROCEDURES

LG Monitoring View (LGMV) Diagnostic Software

LG Monitoring View (LGMV) Diagnostic Software and Cable - Continued.

1. Data

- Data Saving Start: Recording of real time data to a separate file created to be stored on the user's computer.
- Data Loading Start: Recorded data from a saved ".CSV" file can be loaded to create an LGMV session.

2. Monitoring

- Electrical: The lower half of main screen is changed to show Inverter Compressor Amps, Volts, Power Hz, Inverter control board fan Hz.

Error Codes

LGMV software helps the service technician or commissioning agent to troubleshoot system operation issues by displaying malfunction codes. These error codes can be seen on the main screen of the LGMV software program. For an overview of Single Zone unit error codes, see Error Codes section. For detailed information on how to troubleshoot individual error codes, see the Single Zone Wall Mount Service Manual.

Figure 104: Error Code Screen.

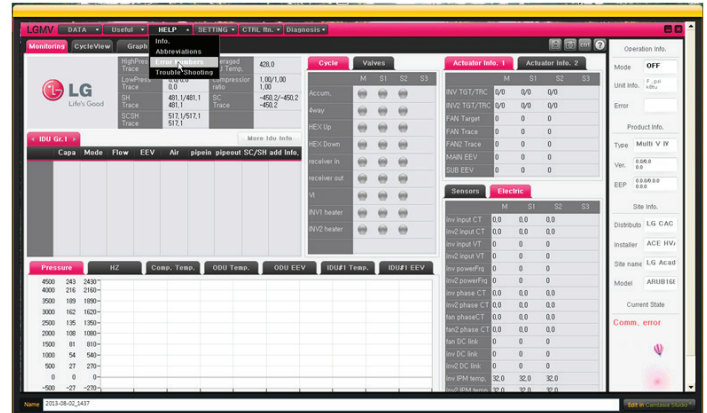

The software is available in a high version with all of the features listed above. The low version has all features as the high version without Target High Pressure and Target Low Pressure values shown on main screen.

In lieu of connecting to the Water Source Unit (WSU), user has the option to connect to IDU with the use of a USB to RS-485 connector kit. When connected through IDU, user will not be able to record data.

This software can be used to both commission new systems and troubleshoot existing systems. LGMV data can be recorded to a ".CSV" file and emailed to an LG representative to assist with diagnostic evaluations.

Note:

- Contact an LG representative for minimum LGMV PC requirements.
- Images on these pages are examples of LGMV screenshots. Actual images may differ depending on the version of the software and the units installed.

FINAL INSTALLATION PROCEDURES

LG ThinQ

LG ThinQ

LG ThinQ is a built-in Wi-Fi module, along with a free smart phone app that provides monitoring and remote control capabilities for certain LG single zone systems. The app has the following features and benefits:

- Sign in to the app using LG credentials, or using Google® or Facebook® login credentials. Users only have to log in to the app once; the app remembers login details for subsequent logins.
- View current temperature settings of the air conditioning unit and change temperature, fan speed, and air flow direction from anywhere in the house or at a remote location (through the use of wireless connection). Multiple users can control the household air conditioning unit remotely.
- Monitor filter usage of the unit.
- Set up weekly schedules to start and stop air conditioner activity.
- Set up the unit to run in different Modes, depending on the user's schedule. Set up specific temperatures for when the user is home, away on vacation, or sleeping.
- Troubleshoot problems, and view tips on general maintenance of the system using the Smart Diagnosis function.

**Google is a registered trademark of Google Inc.; Facebook is a registered trademark of Facebook.*

Contact your LG Sales Representative or visit www.lghvac.com for system requirements, how to download the app, a user's manual, or other information.

Figure 105: Example of an LG ThinQ Screen (appearances may differ depending on version of software).

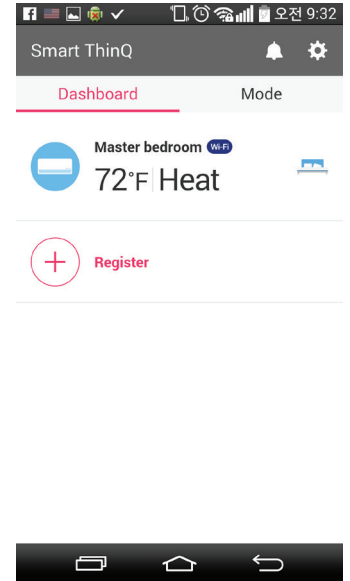

FINAL INSTALLATION PROCEDURES

Error Codes

Troubleshooting Using Error Codes

Refer to the tables below and on the next page for information on the error codes that are generated from the indoor and outdoor units. These codes are the most common that will manifest through these units. The system installed might generate additional codes not listed here. Contact an LG trained service provider if these types of errors are seen, and a simple power down and boot up has not corrected the issue. The end user should not attempt to fix the system.

Error Codes

- Error codes indicate different types of unit failures, assist in self-diagnosis and to track the frequency of occurrence.
- Error codes are shown on the LEDs of indoor units, wired remote controller, the outdoor unit control board, and LG Monitoring View (LGMV) Diagnostic Software, depending on the system installed.
- If two or more errors occur simultaneously, the error code with the larger issue is displayed first.
- To resume system operation after an error code is resolved, cycle the power off, then back on.
- After error is resolved, the error code does not display.

Figure 106: Wired Remote Controller Display.

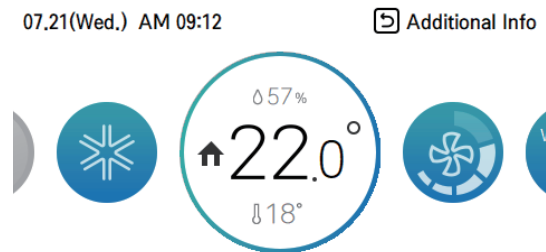

Decoding the Error Display

The first and second number on the LED indicates error number. Example: 21 = LED1 2x blink, LED2 1x blink.

Error Code Nomenclature Definitions

- MICOM: Non-volatile memory chip where unit setup information is stored.
- EEPROM: Non-volatile memory chip where device identification, size, and factory defined default component operating parameters are stored.

⚠ WARNING

If incorrect voltage is supplied, the protection circuit will turn the system off to prevent fire and / or electric shock, which will cause physical injury or death.

Note:

If incorrect voltage is supplied, the protection circuit will turn the system off to prevent fire and / or electric shock. The system will automatically restart after three (3) minutes.

Table 33: Mid-Static Ducted Indoor Unit Error Codes.

Error Code	Description	Details	Indoor Unit Operation Status
01	Indoor Unit Room Air Temperature Room Sensor Error	Indoor unit air temperature sensor is disconnected, shorted, or opened.	Off
02	Indoor Unit Inlet Pipe Sensor Error	Indoor unit inlet pipe temperature sensor is disconnected, shorted, or opened.	Off
03	Remote Controller Error	Indoor unit PCB is not receiving a signal from the wired remote controller (if installed).	Off
04	Drain Pump Error	Drain pump malfunction.	Off
05	Communication Error Between Indoor Unit and Outdoor Unit	Indoor unit PCB is not receiving signal from outdoor unit.	Off
06	Indoor Unit Outlet Pipe Sensor Error	Indoor unit outlet pipe temperature sensor is disconnected, shorted, or opened.	Off
09	Indoor Unit EEPROM Error	Indoor unit EEPROM serial number marked on is 0 or FFFFFFFF.	Off
10	Indoor Unit BLDC Motor Fan Lock	Indoor unit fan motor connection is disconnected. Indoor unit fan motor lock has failed.	Off

FINAL INSTALLATION PROCEDURES

Error Codes

Troubleshooting Using Error Codes, LUU090HV ~ LUU240HV Outdoor Units

Figure 107: Location of LEDs in LUU090HV ~ LUU240HV Outdoor Units.

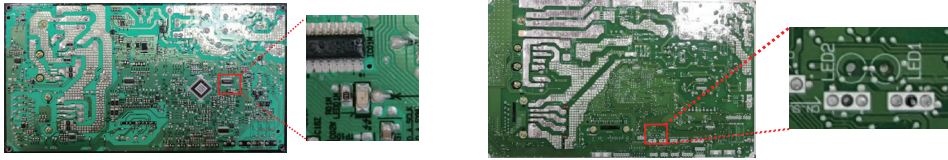

LUU090HV, LUU120HV

LUU180HV, LUU240HV

Figure 108: Example of Outdoor Unit Error Code 21 (DC Peak).

Example: Error 21 (DC Peak)

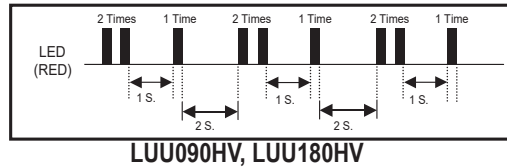

Example: Error 21 (DC Peak)

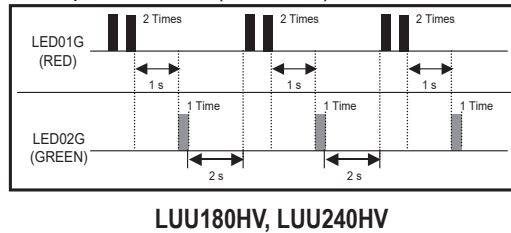

Note:

Outdoor unit errors can be checked on the LED of the wired remote controller (optional; sold separately), or the outdoor unit LED.

Note:

- The error code will shut the unit down, depending on the nature of the particular error code (it may or may not auto-restart).
- LED 1 blinks if error code number is in the double digits (tens place); LED 2 blinks if error code number is in the single digits (ones place).

Table 34: LUU090HV ~ LUU240HV Outdoor Unit Error Codes.

Error Code	Description	Wired Remote Controller Error Code	No. of Times ODU LEDs Blink		Frequency	Operation Status
			LED1 (Red)	LED2 (Green)		
21	DC Peak (IPM Fault); Compressor DC voltage was too high	CH21	2X	1X	10X in 1 Hour	Off
22	Current Transformer2 (CT2) error; Current AC input too high	CH22	2X	2X	Infinite Restart	Off
23	DC Link Error (High / Low DC Voltage)	CH23	2X	3X	Infinite Restart	Off
24	Pressure Switch / Heater Sink.	CH24	2X	4X	10X in 1 Hour	Off
26	DC Comp Position Error (not providing rotation), Locking	CH26	2X	6X	10X in 1 Hour	Off
27	PSC / PFC overcurrent error (HW); Current to inverter compressor too high	CH27	2X	7X	10X in 1 Hour	Off
29	Compressor phase overcurrent error	CH29	2X	9X	10X in 1 Hour	Off
32	Inverter Compressor Discharge Pipe (D-Pipe) Overheat	CH32	3X	2X	Infinite Restart	Off
35	Low Pressure Error	CH35	3X	5X		Off
41	Inverter Compressor Discharge Pipe Sensor is disconnected or shorted out	CH41	4X	1X	1X in 1 Hour	Off
43	High Pressure Sensor is disconnected or shorted out	CH43	4X	3X	1X in 1 Hour	Off
44	Outdoor inlet sensor is disconnected or shorted out	CH44	4X	4X	1X in 1 Hour	Off
45	Middle thermistor of outdoor unit condenser coil is disconnected or shorted out	CH45	4X	5X	1X in 1 Hour	Off
46	Outdoor unit suction pipe thermistor is disconnected or shorted out	CH46	4X	6X	1X in 1 Hour	Off
48	Outdoor unit condenser coil outlet (liquid piping) thermistor is disconnected or shorted out.	CH48	4X	8X	1X in 1 Hour	Off
51	Over Capacity	CH51	5X	1X	1X in 1 Hour	Off
53	Communication failure between outdoor unit and indoor unit	CH53	5X	3X	1X in 1 Hour	Off
54	Open Phase Error	CH54	5X	4X	1X in 1 Hour	Off
60	Outdoor unit printed circuit board (PCB) EEPROM check sum error	CH60	6X	-	1X in 1 Hour	Off
61	Outdoor unit condenser middle piping temperature is too high	CH61	6X	1X	Infinite Restart	Off
62	Outdoor unit inverter compressor PCB heat sink temperature is too high	CH62	6X	2X	Infinite Restart	Off
65	Outdoor unit heat sink thermistor has disconnected or has shorted out	CH65	6X	5X	1X in 1 Hour	Off
67	Outdoor brushless direct current (BLDC) fan motor lock error	CH67	6X	7X	10X in 1 Hour	Off
73	PSC / PFC overcurrent error (SW)	CH73	7X	3X	Infinite Restart	Off

CAUTIONS FOR REFRIGERANT LEAKS

Cautions for Refrigerant Leaks / Introduction

ASHRAE Standards 15-2010 and 34-2010 offer guidelines that address refrigerant safety and the maximum allowable concentration of refrigerant in an occupied space. Refrigerant will dissipate into the atmosphere, but a certain volume of air is required for this to occur safely. For R410A refrigerant, the maximum allowable concentration is 0.026 lbs./ft³ per 1,000 ft³ of air in an occupied space. Buildings with twenty-four (24) hour occupancy allow half of that concentration.¹

ASHRAE Standards 15 and 34 assume that if a system develops a leak, its entire refrigerant charge will dump into the area where the leak occurs. To meet ASHRAE Standards 15 and 34, calculate the refrigerant concentration that may occur in the smallest room volume on the system, and compare the results to the maximum allowable concentration number (see below for information on how to calculate the refrigerant concentration).¹ Also consult state and local codes in regards to refrigerant safety.

⚠ WARNING

Verify the maximum refrigerant concentration level in the space where the indoor unit will be mounted meets the concentration limit for the application. If the refrigerant leaks and safety limits are exceeded, it could result in personal injuries or death from oxygen depletion.

Note:

Take appropriate actions at the end of HVAC equipment life to recover, recycle, reclaim or destroy R410A refrigerant according to applicable US EPA rules.

To calculate the potential refrigerant concentration level (RCL):

1. Measure the occupied space dimensions (in feet).
2. Calculate the cubic foot volume of air in the smallest occupied space. (To obtain a detailed overview of the RCL, perform the same calculations to the second smallest zone, the third smallest zone until the RCL is obtained for all zones. Also, pay special attention to areas such as basements, etc., where refrigerant cannot dissipate easily.)
3. Divide the refrigerant charge of the Single Zone system serving the area in pounds by the results of step 1.
4. If the calculation indicates that the potential refrigerant concentration level is higher than the allowed RCL, increase the cubic volume of the smallest occupied space or modify the piping system design.
5. The allowable RCL limit for most applications must be equal to or less than 0.026 lbs./ft³. However, in special occupied spaces, such as hospitals and nursing homes, where occupants may have limited mobility, the allowable RCL limit is cut in half. See ASHRAE Standard 34-2007 and local codes for detailed information.¹

Refrigerant Concentration Limit (RCL) Calculations

To calculate total refrigerant amount per system:

Amount of Factory-Charged Refrigerant per Outdoor Unit	+	Amount of Additional Refrigerant Trim Charge	=	Total System Refrigerant Charge
---	----------	---	----------	--

$$\text{RCL (lbs./ft}^3\text{)} = \frac{\text{Total System Refrigerant Charge (lbs.)}}{\text{Volume of Smallest Occupied Space (ft}^3\text{)}}$$

¹American Society of Heating, Refrigeration and Air Conditioning Engineers, Inc. (ASHRAE). Atlanta, GA. ASHRAE, Inc. Information about ASHRAE Standard 15-2010 / 34-2010 and addenda current as of the date of this publication.

INSTALLATION CHECKLIST

Major Component Rough-In

Description	Check
Single Zone outdoor unit was connected properly per local code and the product installation procedures.	
All literature and bagged accessories have been removed from the fan discharge.	
Indoor unit was installed, properly supported, and located indoors in a non-corrosive environment.	
Single Zone unit's condensate drain line was connected and routed where it properly drains away or, if installed in a mechanical room, was connected and properly routed to a drain terminal.	

Piping and Insulation

Description	Check
Single-zone and multi-zone duct-free split systems: ACR copper piping rated at the system working pressure for R410A was used.	
All refrigerant pipes and valves were insulated separately. Insulation is positioned up against the walls of the indoor unit. No gaps shown. Insulation was not compressed at clamps and hangers.	

Brazing Practices

Description	Check
Medical grade (there are 4 available) dry nitrogen for purging during brazing was used (constant 3 psi while brazing).	
15% silver brazing material only.	

Refrigerant Piping

Description	Check
All pipe materials were properly stored, capped, and clean. All burrs were removed after cutting and pipe ends were reamed before brazing.	
During refrigerant pipe installation, for each segment of pipe, a record was made of the pipe length (including expansion loops, offsets, double-back sections), and sizes, as well as the quantity and type of elbows used.	
Expansion loops, coils or other acceptable measures are provided where necessary to absorb temperature-change based pipe movement.	
A torque wrench and backup wrench were used to tighten all flare connections.	
The back side of all flares were lubricated with a small drop of PVE refrigeration oil before tightening flare fittings.	
Ensure all field made flares are 45°. Use factory-supplied flare nuts only.	
Pipe segments were secured to the structure using a combination of fixed and floating clamps, and all wall penetrations were sleeved.	
Pipe insulation was not compressed at any point.	
No oil traps, solenoid valves, sight glasses, filter driers, or any other unauthorized refrigerant specialties were present.	
(Optional) High quality R-410A rated full port ball valves (Schrader between the valve body and the indoor units) used at the indoor unit and at will in the refrigerant piping.	

Condensate Pump / Drain Installation

Description	Check
Condensate drain installed on indoor units. Extended condensate piping material used is acceptable under local code. Insulated to prevent condensation.	
Indoor unit condensate drain pipes were installed correctly.	
Indoor unit with a gravity drain were level or slightly canted toward the drain connection and is supported properly.	
Drain lines are properly insulated to prevent condensation.	

Power Wire and Communication Cables

Description	Check
Power wiring to the Single Zone outdoor unit is solid or stranded, and complies with all local and national electrical codes.	
Power wiring was connected to a single phase 208-230V source.	
Ground wire was installed and properly terminated at the unit.	
The power supplied was clean with voltage fluctuations within specifications. ($\pm 10\%$ of nameplate).	
Power wiring to the Single Zone outdoor unit was installed per all local electrical code requirements.	
Communication / connection (power) cable from the single zone outdoor unit to the indoor unit must use a minimum of 14 AWG, four (4) conductor, stranded, shielded or unshielded (if shielded, it must be grounded to the chassis of the outdoor unit only), and must comply with applicable local and national codes.	
Use of 14 AWG, four (4) conductor, stranded, shielded or unshielded wire is allowed for lengths up to the published maximum pipe length, plus recommended slack at both ends.	
Wiring to the indoor unit was installed per all local electrical code requirements.	
Communication / connection (power) wiring from the outdoor unit to the indoor unit can be run in the same conduit.	
Communication type RS-485-BUS type.	
22-3 AWG, twisted, stranded, unshielded cable (minimum) was used between the indoor unit and its zone controller (if present). No cables were spliced, and no wire caps are present.	
LG-supplied cable was used between the indoor unit and its zone controller. No cables were spliced and no wire caps are present.	
Appropriate crimping tool was used to attach ring or spade terminals at all power wiring and control cable terminations.	
Power and control wires were run in the same conduit (outdoor unit to indoor only) as provided in the product installation manual.	
Power to outdoor unit and power/communications to indoor unit CANNOT be run in the same conduit.	

Inverter

162279



LG Electronics, U.S.A., Inc.
Air Conditioning Technologies
4300 North Point Parkway
Alpharetta, Georgia 30022
www.lghvac.com