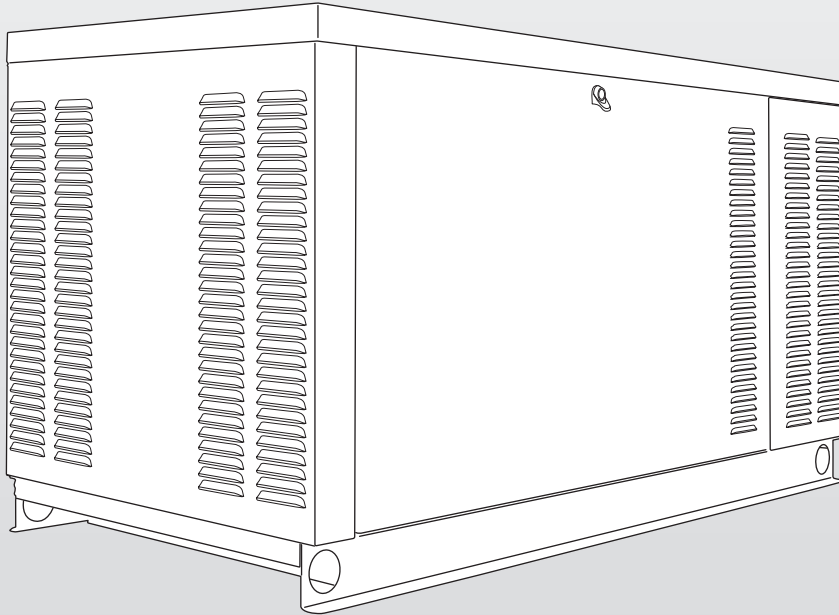




# Owner's Manual

## Stationary Emergency Generator



**▲ CAUTION!**

**▲ NOT INTENDED FOR USE IN CRITICAL LIFE SUPPORT APPLICATIONS. ONLY QUALIFIED ELECTRICIANS OR CONTRACTORS SHOULD ATTEMPT INSTALLATION! DEADLY EXHAUST FUMES! OUTDOOR INSTALLATION ONLY!**


**2.4L**  
**22/27kW Models**  
**EPA Certified**

**This manual should remain with the unit.**

# Table of Contents

<b>SECTION</b>	<b>PAGE</b>		
<b>INTRODUCTION</b> .....	<b>1-1</b>		
Read this Manual Thoroughly .....	1-1		
Operation and Maintenance .....	1-1		
How to Obtain Service .....	1-1		
<b>SAFETY RULES</b> .....	<b>1-2</b>		
<b>GENERAL INFORMATION</b> .....	<b>2-1</b>		
Identification Record .....	2-1		
Data Label .....	2-1		
<b>EQUIPMENT DESCRIPTION</b> .....	<b>3-1</b>		
Equipment Description .....	3-1		
Engine Oil Recommendations .....	3-1		
Coolant Recommendations .....	3-1		
<b>ENGINE PROTECTIVE DEVICES</b> .....	<b>4-1</b>		
Engine Protective Devices .....	4-1		
High Coolant Temperature Sender .....	4-1		
Low Coolant Level Sensor .....	4-1		
Low Oil Pressure Switch .....	4-1		
Overcrank Shutdown .....	4-1		
Overspeed Shutdown .....	4-1		
RPM Sensor Loss Shutdown .....	4-1		
DC Fuses .....	4-1		
<b>FUEL SYSTEM</b> .....	<b>5-1</b>		
Fuel Requirements .....	5-1		
Natural Gas Fuel System .....	5-1		
Propane Vapor Withdrawal Fuel System .....	5-1		
LP Liquid Fuel System .....	5-1		
<b>SPECIFICATIONS</b> .....	<b>6-1</b>		
Stationary Emergency Generator .....	6-1		
Engine .....	6-1		
Cooling System .....	6-1		
Fuel System .....	6-1		
Electrical System .....	6-1		
Weather and Maintenance Kits .....	6-2		
Reconfiguring the Fuel System .....	6-2		
Fuel System .....	6-2		
Control Panel .....	6-2		
<b>GENERAL INFORMATION</b> .....	<b>7-1</b>		
Alternator AC Lead Connections .....	7-1		
Four-lead, Single-phase Stator .....	7-1		
Alternator Power Winding Connections .....	7-1		
3-phase Alternators ("Y" Configuration) .....	7-1		
3-phase Alternators ("Delta" Configuration) .....	7-2		
<b>CONTROL PANEL</b> .....	<b>8-1</b>		
Control Panel Interface .....	8-1		
Using the Auto/Off/Manual Switch .....	8-1		
Activate the Generator .....	8-1		
Display Interface Menus .....	8-1		
Activation Chart .....	8-2		
Setting the Exercise Timer .....	8-3		
Low Speed Exercise .....	8-3		
User Adjustable Settings .....	8-3		
Fuel Conversion .....	8-3		
Operation .....	8-3		
Automatic Transfer Operation .....	8-3		
Sequence of Automatic Operation .....	8-4		
Crank Cycles and Overcrank Shutdown .....	8-4		
Auto Start .....	8-4		
Manual Start .....	8-4		
		Alarm and Warning Messages .....	8-4
		Low Oil Pressure Shutdown Alarm .....	8-4
		High Coolant Temperature Shutdown Alarm .....	8-4
		Overcrank Shutdown Alarm .....	8-4
		Overspeed Shutdown Alarm .....	8-4
		RPM Sensor Failure Shutdown Alarm .....	8-4
		Under-frequency Shutdown Alarm .....	8-5
		Low Battery Alarm .....	8-5
		Low Battery Warning .....	8-5
		Low Coolant Level Alarm .....	8-5
		Missing Cam Pulse Alarm .....	8-5
		Missing Crank Pulse Alarm .....	8-5
		Low Fuel Pressure Warning .....	8-5
		Governor Sensor Fault Alarm .....	8-5
		Wiring Error Alarm .....	8-5
		Undervoltage Alarm .....	8-5
		Overvoltage Alarm .....	8-6
		Internal Failure Shutdown Alarm .....	8-6
		Canbus Alarm .....	8-6
		Ignition Alarm .....	8-6
		Maintenance Warning .....	8-6
		Alarm Cancel .....	8-6
		Common Alarm Relay .....	8-6
		Maintenance Alerts .....	8-6
		Menu System .....	8-7
		<b>OPERATION</b> .....	<b>9-1</b>
		Stationary Emergency Generator Control and Operation .....	9-1
		Operating Unit with Manual Transfer Switch .....	9-1
		Engine Start-up and Transfer .....	9-1
		Retransfer and Shutdown .....	9-1
		Operating Unit with Automatic Transfer Switch .....	9-1
		<b>MAINTENANCE</b> .....	<b>10-1</b>
		General Maintenance .....	10-1
		Check Engine Oil .....	10-1
		Changing Engine Oil .....	10-1
		Cooling Intake/Outlet .....	10-1
		Inspect Cooling System .....	10-1
		Engine Coolant .....	10-2
		Coolant Change .....	10-2
		Overload Protection for Engine DC Electrical System .....	10-2
		Exercise System .....	10-2
		Perform Visual Inspection .....	10-2
		Inspect Exhaust System .....	10-2
		Check Fan Belt .....	10-2
		Inspect Engine Governor .....	10-2
		Changing the Engine Air Filter .....	10-2
		Spark Plugs .....	10-3
		Battery Maintenance .....	10-3
		Battery Replacement .....	10-3
		Battery Fluid .....	10-3
		Cleaning the Stationary Emergency Generator .....	10-3
		<b>SERVICE SCHEDULE</b> .....	<b>11-1</b>
		<b>TROUBLESHOOTING</b> .....	<b>12-1</b>
		Troubleshooting Guide .....	12-1
		<b>EMISSIONS WARRANTY</b> .....	<b>13-1</b>
		<b>NOTES</b>	
		<b>EXPLODED VIEWS &amp; PARTS LISTS</b>	
		<b>WIRING DIAGRAMS &amp; SCHEMATICS</b>	

# Safety Instructions

 **SAVE THESE INSTRUCTIONS** – The manufacturer suggests that these rules for safe operation be copied and posted in potential hazard areas. Safety should be stressed to all operators, potential operators, and service and repair technicians for this equipment.

## INTRODUCTION

Thank you for purchasing this model of the stationary emergency generator product line.

Every effort was expended to make sure that the information and instructions in this manual were both accurate and current at the time the manual was written. However, the manufacturer reserves the right to change, alter or otherwise improve this product(s) at any time without prior notice.

## READ THIS MANUAL THOROUGHLY

If any portion of this manual is not understood, contact the nearest Service Dealer for starting, operating and servicing procedures.

Throughout this publication, and on tags and decals affixed to the generator, DANGER, WARNING, CAUTION and NOTE blocks are used to alert personnel to special instructions about a particular service or operation that may be hazardous if performed incorrectly or carelessly. Observe them carefully. Their definitions are as follows:

### **DANGER!**

**INDICATES A HAZARDOUS SITUATION OR ACTION WHICH, IF NOT AVOIDED, WILL RESULT IN DEATH OR SERIOUS INJURY.**

### **WARNING!**

**Indicates a hazardous situation or action which, if not avoided, could result in death or serious injury.**

### **CAUTION!**

**Indicates a hazardous situation or action which, if not avoided, could result in minor or moderate injury.**

#### **NOTE:**

**Notes contain additional information important to a procedure and will be found within the regular text body of this manual.**

These safety warnings cannot eliminate the hazards that they indicate. Common sense and strict compliance with the special instructions while performing the service are essential to preventing accidents.

Four commonly used safety symbols accompany the DANGER, WARNING and CAUTION blocks. The type of information each indicates is as follows:

 **This symbol points out important safety information that, if not followed, could endanger personal safety and/or property of others.**

 **This symbol points out potential explosion hazard.**

 **This symbol points out potential fire hazard.**

 **This symbol points out potential electrical shock hazard.**

The operator is responsible for proper and safe use of the equipment. The manufacturer strongly recommends that the operator read this Owner's Manual and thoroughly understand all instructions before using this equipment. The manufacturer also strongly recommends instructing other users to properly start and operate the unit. This prepares them if they need to operate the equipment in an emergency.

**For safety reasons, the manufacturer recommends that this equipment be installed, serviced and repaired by a Service Dealer or other competent, qualified electrician or installation technician who is familiar with applicable codes, standards and regulations. The operator also must comply with all such codes, standards and regulations.**

## OPERATION AND MAINTENANCE

It is the operator's responsibility to perform all safety checks, to make sure that all maintenance for safe operation is performed promptly, and to have the equipment checked periodically by a Service Dealer. Normal maintenance service and replacement of parts are the responsibility of the owner/operator and, as such, are not considered defects in materials or workmanship within the terms of the warranty. Individual operating habits and usage contribute to the need for maintenance service.

Proper maintenance and care of the generator ensure a minimum number of problems and keep operating expenses at a minimum. See a Service Dealer for service aids and accessories.

Operating instructions presented in this manual assume that the generator electric system has been installed by a Service Dealer or other competent, qualified contractor. Installation of this equipment is not a "do-it-yourself" project.

## HOW TO OBTAIN SERVICE

When the generator requires servicing or repairs, simply contact a Service Dealer for assistance. Service technicians are factory-trained and are capable of handling all service needs.

When contacting a dealer about parts and service, always supply the complete Model Number, Serial Number and Type Code (where applicable) from the DATA LABEL that is affixed to the unit.

# Safety Instructions

## SAFETY RULES

Study these SAFETY RULES carefully before installing, operating or servicing this equipment. Become familiar with this Owner's Manual and with the unit. The generator can operate safely, efficiently and reliably only if it is properly installed, operated and maintained. Many accidents are caused by failing to follow simple and fundamental rules or precautions.

The manufacturer cannot anticipate every possible circumstance that might involve a hazard. The warnings in this manual, and on tags and decals affixed to the unit are, therefore, not all inclusive. If a procedure, work method or operating technique is used that the manufacturer does not specifically recommend, ensure that it is safe for others. Also make sure the procedure, work method or operating technique utilized does not render the generator unsafe.

### **⚠ DANGER!**

**⚠ Despite the safe design of this generator, operating this equipment imprudently, neglecting its maintenance or being careless can cause possible injury or death. Permit only responsible and capable persons to install, operate or maintain this equipment.**

**⚠ Potentially lethal voltages are generated by these machines. Ensure all steps are taken to render the machine safe before attempting to work on the generator.**

**⚠ Parts of the generator are rotating and/or hot during operation. Exercise care near running generators.**

## GENERAL HAZARDS

- For safety reasons, the manufacturer recommends that this equipment be installed, serviced and repaired by a Service Dealer or other competent, qualified electrician or installation technician who is familiar with applicable codes, standards and regulations. The operator also must comply with all such codes, standards and regulations.
- Installation, operation, servicing and repair of this (and related) equipment must always comply with applicable codes, standards, laws and regulations. Adhere strictly to local, state and national electrical and building codes. Comply with regulations the Occupational Safety and Health Administration (OSHA) has established. Also, ensure that the generator is installed, operated and serviced in accordance with the manufacturer's instructions and recommendations. Following installation, do nothing that might render the unit unsafe or in noncompliance with the aforementioned codes, standards, laws and regulations.

- The engine exhaust fumes contain carbon monoxide gas, which can be DEADLY. This dangerous gas, if breathed in sufficient concentrations, can cause unconsciousness or even death. For that reason, adequate ventilation must be provided. This should be considered prior to installing the generator. The unit should be positioned to direct exhaust gasses safely away from any building where people, animals, etc., will not be harmed. Any exhaust stacks that ship loose with the unit must be installed properly per the manufacturer's instruction, and in strict compliance with applicable codes and standards.
- Keep hands, feet, clothing, etc., away from drive belts, fans, and other moving or hot parts. Never remove any drive belt or fan guard while the unit is operating.
- Adequate, unobstructed flow of cooling and ventilating air is critical in any room or building housing the generator to prevent buildup of explosive gases and to ensure correct generator operation. Do not alter the installation or permit even partial blockage of ventilation provisions, as this can seriously affect safe operation of the generator.
- Keep the area around the generator clean and uncluttered. Remove any materials that could become hazardous.
- When working on this equipment, remain alert at all times. Never work on the equipment when physically or mentally fatigued.
- Inspect the generator regularly, and promptly repair or replace all worn, damaged or defective parts using only factory-approved parts.
- Before performing any maintenance on the generator, disconnect its battery cables to prevent accidental start-up. Disconnect the cable from the battery post indicated by a NEGATIVE, NEG or (-) first. Reconnect that cable last.
- Never use the generator or any of its parts as a step. Stepping on the unit can stress and break parts, and may result in dangerous operating conditions from leaking exhaust gases, fuel leakage, oil leakage, etc.

## ELECTRICAL HAZARDS

- All stationary emergency generators covered by this manual produce dangerous electrical voltages and can cause fatal electrical shock. Utility power delivers extremely high and dangerous voltages to the transfer switch as well as the generator. Avoid contact with bare wires, terminals, connections, etc., on the generator as well as the transfer switch, if applicable. Ensure all appropriate covers, guards and barriers are in place before operating the generator. If work must be done around an operating unit, stand on an insulated, dry surface to reduce shock hazard.
- Do not handle any kind of electrical device while standing in water, while barefoot, or while hands or feet are wet. DANGEROUS ELECTRICAL SHOCK MAY RESULT.

# Safety Instructions

- If personnel must stand on metal or concrete while installing, operating, servicing, adjusting or repairing this equipment, place insulative mats over a dry wooden platform. Work on the equipment only while standing on such insulative mats.
- The National Electrical Code (NEC) requires the frame and external electrically conductive parts of the generator to be connected to an approved earth ground. This grounding will help prevent dangerous electrical shock that might be caused by a ground fault condition in the generator or by static electricity. Never disconnect the ground wire.
- Wire gauge sizes of electrical wiring, cables and cord sets must be adequate to handle the maximum electrical current (ampacity) to which they will be subjected.
- Before installing or servicing this (and related) equipment, make sure that all power voltage supplies are positively turned off at their source. Failure to do so will result in hazardous and possibly fatal electrical shock.
- Connecting this unit to an electrical system normally supplied by an electric utility shall be by means of a transfer switch so as to isolate the generator electric system from the electric utility distribution system when the generator is operating. Failure to isolate the two electric system power sources from each other by such means will result in damage to the generator and may also result in injury or death to utility power workers due to backfeed of electrical energy.
- Stationary emergency generators installed with an automatic transfer switch will crank and start automatically when normal (utility) source voltage is removed or is below an acceptable preset level. To prevent such automatic start-up and possible injury to personnel, disable the generator's automatic start circuit (battery cables, etc.) before working on or around the unit. Then, place a "Do Not Operate" tag on the generator control panel and on the transfer switch.
- In case of accident caused by electric shock, immediately shut down the source of electrical power. If this is not possible, attempt to free the victim from the live conductor. **AVOID DIRECT CONTACT WITH THE VICTIM.** Use a nonconducting implement, such as a dry rope or board, to free the victim from the live conductor. If the victim is unconscious, apply first aid and get immediate medical help.
- Never wear jewelry when working on this equipment. Jewelry can conduct electricity resulting in electric shock, or may get caught in moving components causing injury.

## **FIRE HAZARDS**

- Keep a fire extinguisher near the generator at all times. Do NOT use any carbon tetra-chloride type extinguisher. Its fumes are toxic, and the liquid can deteriorate wiring insulation. Keep the extinguisher properly charged and be familiar with its use. If there are any questions pertaining to fire extinguishers, consult the local fire department.

## **EXPLOSION HAZARDS**

- Properly ventilate any room or building housing the generator to prevent build-up of explosive gas.
- Do not smoke around the generator. Wipe up any fuel or oil spills immediately. Ensure that no combustible materials are left in the generator compartment, or on or near the generator, as FIRE or EXPLOSION may result. Keep the area surrounding the generator clean and free from debris.
- These generators may operate using one of several types of fuels. All fuel types are potentially FLAMMABLE and/or EXPLOSIVE and should be handled with care. Comply with all laws regulating the storage and handling of fuels. Inspect the unit's fuel system frequently and correct any leaks immediately. Fuel supply lines must be properly installed, purged and leak tested according to applicable fuel-gas codes before placing this equipment into service.
- Diesel fuels are highly FLAMMABLE. Gaseous fluids such as natural gas and liquid propane (LP) gas are extremely EXPLOSIVE. Natural gas is lighter than air, and LP gas is heavier than air; install leak detectors accordingly.

### **CALIFORNIA PROPOSITION 65 WARNING**

Engine exhaust and some of its constituents are known to the State of California to cause cancer, birth defects and other reproductive harm.

### **CALIFORNIA PROPOSITION 65 WARNING**

This product contains or emits chemicals known to the State of California to cause cancer, birth defects and other reproductive harm.

# General Information

## IDENTIFICATION RECORD

### DATA LABEL

Every generator set has a DATA LABEL that contains important information pertinent to the generator. The data label, which can be found attached to the generator's lower connection box, lists the unit's serial number and its rated voltage, amps, wattage capacity, phase, frequency, rpm, power factor, production date, etc.

### NOTE:

For actual information related to this particular model, please refer to the Manual Drawing Listing located at the end of this manual, or to the data label affixed to the unit.

### Stationary Emergency Generator Model and Serial Number

This number is the key to numerous engineering and manufacturing details pertaining to your unit. Always supply this number when requesting service, ordering parts or seeking information.

### Data Label

MODEL	<input type="text"/>	<input type="text"/>	
PROD DATE	<input type="text"/>	SERIAL <input type="text"/>	
KW <input type="text"/>	KVA <input type="text"/>	PHASE <input type="text"/>	HERTZ <input type="text"/>
VOLT <input type="text"/>	AMP <input type="text"/>	PWR FACT <input type="text"/>	ALT RPM <input type="text"/>
ENG RPM <input type="text"/>	TYPE CODE <input type="text"/>		
ALT SUBTRANS REACTANCE <input type="text"/>	ALT TRANS REACTANCE <input type="text"/>		
CLASS <input type="checkbox"/> ROTOR <input type="checkbox"/> STATOR WINDING INS AT 25°C AMB			
<input type="text"/>		<input type="text"/>	
MODEL NO (CAT/CUST NO)		SERIAL NO	
<input type="text"/>		<input type="text"/>	
<input type="text"/>		<input type="text"/>	

0G2110 REV C

### EQUIPMENT DESCRIPTION

This equipment is a revolving field, alternating current Stationary Emergency Generator set. It is powered by a gaseous fueled engine operating at 1800 rpm for 4-pole direct drive units, 3600 rpm for 2-pole direct drive units and 2300 - 3000 rpm for quiet drive gear units. See the Specifications section for exact numbers. The unit comes complete with a sound attenuated enclosure, internally mounted muffler, control console, mainline circuit breaker, battery charger, and protective alarms as explained in the following paragraph.

All AC connections, including the power leads from the alternator, 120 volt battery charger input and control connections to the transfer switch are available in the main connection box.

The Stationary Emergency Generator incorporates the following generator features:

- Rotor and Stator insulation is Class H rated as defined by NEMA MG1-32.6, MG1-1.66. The generator is self ventilated and drip-proof constructed.
- The voltage waveform deviation, total harmonic content of the AC waveform and telephone influence factor have been evaluated and are acceptable according to NEMA MG1-32.

### ENGINE OIL RECOMMENDATIONS

The unit has been filled with 5W-30 engine oil at the factory. Use a high-quality detergent oil classified "For Service SJ or SH." Detergent oils keep the engine cleaner and reduce carbon deposits. When changing the engine oil, be sure to use 5W-30 engine oil (synthetic oil is recommended).

#### ⚠ CAUTION!

- ⚠ **Any attempt to crank or start the engine before it has been properly serviced with the recommended oil may result in an engine failure.**

#### NOTE:

For temperatures below 32° F, it is strongly recommended to use the optional Cold Weather Start Kit (part number listed in the Specification Section). The oil grade for temperatures below 32° F is 5W-30 synthetic oil.

### COOLANT RECOMMENDATIONS

Use a mixture of half low silicate ethylene glycol base anti-freeze and deionized water. Cooling system capacity is listed in the specifications. Use only deionized water and only low silicate anti-freeze. If desired, add a high quality rust inhibitor to the recommended coolant mixture. When adding coolant, always add the recommended 50-50 mixture.

#### ⚠ CAUTION!

- ⚠ **Do not use any chromate base rust inhibitor with ethylene glycol base anti-freeze or chromium hydroxide ("green slime") forms and will cause overheating. Engines that have been operated with a chromate base rust inhibitor must be chemically cleaned before adding ethylene glycol base anti-freeze. Using any high silicate anti-freeze boosters or additives will also cause overheating. The manufacturer also recommends that any soluble oil inhibitor is NOT used for this equipment.**

#### ⚠ DANGER!

- ⚠ **Do not remove the radiator pressure cap while the engine is hot or serious burns from boiling liquid or steam could result.**
- ⚠ **Ethylene glycol base antifreeze is poisonous. Do not use mouth to siphon coolant from the radiator, recovery bottle or any container. Wash hands thoroughly after handling. Never store used antifreeze in an open container because animals are attracted to the smell and taste of antifreeze even though it is poisonous to them.**

# Engine Protective Devices

## ENGINE PROTECTIVE DEVICES

The Stationary Emergency Generator may be required to operate for long periods of time without an operator on hand to monitor such engine conditions as coolant temperature, oil pressure or rpm. For that reason, the engine has several devices designed to protect it against potentially damaging conditions by automatically shutting down the unit when the oil pressure is too low, the coolant temperature is too high, the coolant level is too low, or the engine is running too fast.

### NOTE:

Engine protective switches and sensors are mentioned here for the reader's convenience. Also refer to the applicable control panel manual for additional automatic engine shutdown information.

### HIGH COOLANT TEMPERATURE SENDER

An analog coolant temperature sender, located in the engine's cooling system will cause an engine shutdown if the temperature should exceed approximately 125° C (257° F). The generator will automatically restart once the temperature has returned to a safe operating level.

### LOW COOLANT LEVEL SENSOR

To prevent overheating, the engine has a low coolant level sensor. If the level of engine coolant drops below the level of the low coolant level sensor, the engine automatically shuts down.

### LOW OIL PRESSURE SWITCH

This switch has normally closed contacts that are held open by engine oil pressure during cranking and operating. Should oil pressure drop below the 8 psi range, switch contacts close, and the engine shuts down. The unit should not be restarted until oil is added, and the AUTO/OFF/MANUAL switch must be turned to OFF and then back to AUTO.

### OVERCRANK SHUTDOWN

After a prespecified duration of cranking, this function ends the cranking if the engine has failed to start. The overcrank message will turn ON. Turn OFF the AUTO/OFF/MANUAL switch, then turn switch back to AUTO to reset the generator control board.

### NOTE:

**If the fault is not corrected, the overcrank feature will continue to activate.**

### Approximate Crank Cycle Times

- 15 seconds ON
- 7 seconds OFF
- 7 seconds ON
- 7 seconds OFF
- Repeat for 45 seconds
- Approximately 90 seconds total.

### OVERSPEED SHUTDOWN

A speed circuit controls engine cranking, start-up, operation and shutdown. Engine speed signals are delivered to the circuit board whenever the unit is running. Should the engine overspeed above a safe, preset value, the circuit board initiates an automatic engine shutdown. Contact the nearest Authorized Dealer if this failure occurs.

### RPM SENSOR LOSS SHUTDOWN

If the speed signal to the control panel is lost, engine shutdown will occur.

### DC FUSES

A fuse (7.5 amp) is located on the control panel. It protects the panel components from damaging overload. **Always remove this fuse before commencing work on the generator.** The unit will not start or crank if the fuse is blown.

A fuse (25 amp) is located in the engine wire harness adjacent to the DC alternator. It is used to prevent circuit failure due to DC alternator failure. It will also protect the system in the event of a wiring short-circuit. If this fuse is blown, the generator will not operate. Replace these fuses with the same size, type, and rating.



## FUEL SYSTEM

### FUEL REQUIREMENTS

The Stationary Emergency Generator may be equipped with one of the following fuel systems:

- Natural gas fuel system
- Propane vapor (PV) fuel system
- Liquid propane (LP) fuel system

Recommended fuels should have a Btu content of at least 1,000 Btu's per cubic foot for natural gas; or at least 2,520 Btu's per cubic foot for LP gas. Ask the fuel supplier for the Btu content of the fuel.

Required fuel pressure for **natural gas is 5 inches to 14 inches water column (0.18 to 0.5 psi); and for liquid propane, 5 inches to 14 inches of water column (0.18 to 0.5 psi).**

#### NOTE:

**Any piping used to connect the generator to the fuel supply should be of adequate size to ensure the fuel pressure NEVER drops below five inches water column for natural gas or 5 inches water column for propane vapor for all load ranges. The fuel supply piping shall be sized according to the installation manual using the fuel consumption requirements identified in the Specifications section of the Owner's Manual.**

#### NOTE:

**It is the responsibility of the installer to make sure that only the correct recommended fuel is supplied to the generator fuel system. Thereafter, the owner/operator must make certain that only the proper fuel is supplied.**

### NATURAL GAS FUEL SYSTEM

Natural gas is supplied in its vapor state. In most cases, the gas distribution company provides piping from the main gas distribution line to the standby generator site. The following information applies to natural gas fuel systems.

- Gas pressure in a building is usually regulated by national, state and local codes.
- To reduce gas pressure to a safe level before the gas enters a building, a primary regulator is needed. The natural gas supplier may or may not supply such a regulator.
- It is the responsibility of the gas supplier to make sure sufficient gas pressure is available to operate the primary regulator.
- Gas pressure at the inlet to the fuel shutoff solenoid should not exceed approximately 14 inches water column (0.5 psi).

### PROPANE VAPOR WITHDRAWAL FUEL SYSTEM

This type of system utilizes the vapors formed above the liquid fuel in the supply tank. Approximately 10 to 20 percent of the tank capacity is needed for fuel expansion from the liquid to the vapor state. The vapor withdrawal system is generally best suited for smaller engines that require less fuel. The installer should be aware of the following:

- When ambient temperatures are low and engine fuel consumption is high, the vapor withdrawal system may not function efficiently.
- Ambient temperatures around the supply tank must be high enough to sustain adequate vaporization, or the system will not deliver the needed fuel volume.
- In addition to the cooling effects of ambient air, the vaporization process itself provides an additional cooling effect.

### LP LIQUID FUEL SYSTEM

LP is supplied as a liquid in pressure tanks. It is usually made up of propane, butane, or a mixture of the two gases. Propane tends to vaporize readily even at temperatures as low as -20° F (-29° C). However, butane reverts to its liquid state when temperatures drop below 32° F (0° C).

LP in a liquid withdrawal system must be converted to its gaseous state before it is introduced into the engine carburetor. A vaporizer-converter is generally used to accomplish this. In such a converter, heated engine coolant is ported through the converter to provide the necessary heat for conversion of the fuel from a liquid to a gaseous state.

# Specifications

## SPECIFICATIONS

### STATIONARY EMERGENCY GENERATOR

Type.....Synchronous  
 Rotor Insulation..... Class H  
 Stator Insulation..... Class H  
 Telephone Interference Factor (TIF) ..... < 50  
 Alternator Output Leads 3-phase ..... 4-wire  
 Bearings ..... Sealed Ball  
 Coupling ..... Flexible Disc  
 Load Capacity (Standby Rating) ..... 22/27kW\*

\* NOTE: Generator rating and performance in accordance with ISO8528-5, BS5514, SAE J1349, ISO3046 and DIN 6271 Standards. KW rating is based on LPG fuel and may derate with natural gas and generator specific settings.

Excitation System ..... Direct  
 Generator Output Voltage/kW - 60 Hz

	kW	Amp	CB Size
120/240V, 1-phase, 1.0 pf	22/27	92/113	100/125
120/208V, 3-phase, 0.8 pf	22/27	77/94	80/100
120/240V, 3-phase, 0.8 pf	22/27	66/81	80/90

Generator Locked Rotor KVA Available @ Voltage Dip of 35%

	22kW	27kW
	38 KVA	42 KVA

### ENGINE

Make ..... Generac  
 Model ..... In Line 4  
 Cylinders and Arrangement ..... 4  
 Displacement ..... 2.4 Liter  
 Bore ..... 86.5 mm (3.41 in.)  
 Stroke ..... 100 mm (3.94 in.)  
 Compression Ratio ..... 9.5-to-1  
 Air Intake System ..... Naturally Aspirated  
 Valve Seats ..... Hardened  
 Lifter Type ..... Hydraulic  
 Spark Plug Gap ..... 1.07 - 1.17mm (0.042 - 0.46 inch)

#### Engine Parameters

Rated Synchronous RPM ..... 60 Hz, 1800

#### Exhaust System

Exhaust Flow at Rated Output 60 Hz (22/27kW) .... 165/180 cfm  
 Exhaust Temp. at Rated Output (22/27kW) ..... 900°/1000° F

#### Combustion Air Requirements (Natural Gas)

Flow at rated power, 60 Hz ..... 68 cfm

#### Governor

Type.....Electronic  
 Frequency Regulation..... Isochronous  
 Steady State Regulation ..... ± 0.25%

#### Engine Lubrication System

Type of Oil Pump ..... Gear  
 Oil Filter ..... Full Flow Spin-on, Cartridge  
 Crankcase Oil Capacity ..... 5.25 U.S. qts.  
 (including oil filter capacity)

### COOLING SYSTEM

Type..... Pressurized Closed Recovery  
 Water Pump..... Belt Driven  
 Fan Speed..... 1980 rpm  
 Fan Diameter..... 18.1 inches  
 Fan Mode..... Pusher  
 Air Flow (inlet air including alternator and combustion air) ..... 2400 ft<sup>3</sup>/min.  
 Coolant Capacity ..... (3.0 U.S. gal.)  
 Heat Rejection to Coolant (22/27kW) ..... 99,000/105,000 Btu/h  
 Maximum Operating Air Temp. on Radiator..... 60° C (150° F)  
 Maximum Ambient Temperature ..... 50° C (140° F)

### FUEL SYSTEM

Type of Fuel ..... Natural Gas, Propane Vapor  
 Carburetor..... Down Draft  
 Secondary Fuel Regulator..... Standard  
 Fuel Shut-off Solenoid..... Standard  
 Operating Fuel Pressure ..... 5 in. - 14 in. Water Column

#### Fuel Consumption - ft<sup>3</sup>/hr (Natural Gas/LPV)

	Exercise Cycle	25% Load	50% Load	75% Load	100% Load
22kW	42/16	100/40	190/75	255/101	316/125
27kW	42/16	108/43	197/78	287/114	359/143

### ELECTRICAL SYSTEM

Battery Charge Alternator ..... 12V, 30 Amp  
 Static Battery Charger ..... 2.5 Amp  
 Recommended Battery..... Group 26, 525CCA  
 System Voltage ..... 12 Volts

#### Voltage Regulator

Type..... Electronic  
 Sensing ..... Single-phase  
 Regulation..... ± 1%  
 Features..... Adjustable Voltage and Gain

#### Power Adjustment for Ambient Conditions

Temperature Deration  
 3% for every 10° C above °C (22/27kW) ..... 25  
 1.65% for every 10° above °F (22/27kW) ..... 104/77  
 Altitude Deration  
 1% for every 100 m above m (22/27kW) ..... 183  
 3% for every 1000 ft. above ft. (22/27kW) ..... 2500/600

Controller ..... Nexus

# Specifications

## WEATHER AND MAINTENANCE KITS

To keep the generator running at its peak, the following kits are offered:

- Cold Weather Kit
  - ~ Recommended for climates with temperatures below 32° F.
- Extreme Cold Weather Kit
  - ~ Recommended Block Heater Kit for protection in temperatures below 32° F.
- Scheduled Maintenance Kit
  - ~ Kit includes the recommended parts to maintain the generator. Refer to the Service Schedule for regular maintenance intervals.

For additional information, or to order any of these kits, please contact an Authorized Service Dealer or Customer Service Representative.

## **RECONFIGURING THE FUEL SYSTEM**

### **NOTE:**

**All models are configured to run on natural gas from the factory.**

Before the generator can be operated using a LP fuel source, the fuel system and control panel (refer to the installation drawing for location) must be reconfigured. The steps to reconfigure the generator from a natural gas (NG) to a liquidified petroleum (LP) fuel source are as follows:

### **FUEL SYSTEM**

1. Turn the main gas supply off and disconnect the battery.
2. Remove the carburetor fuel hose from the outlet port of the demand regulator (see Figure 6.1).
3. Disconnect the power wires from the fuel solenoid located on top of the regulator assembly by removing the screw on the front of the connector and pulling the connector forward, away from the solenoid body.
4. Loosen the spring clamp on the small fuel enrichment line and remove the hose from the hose barb.
5. Remove the black pipe assembly from the outlet port of the demand regulator. The solenoid assembly may need to be removed before performing this operation (Figure 6.1).
6. Remove the NG fuel jet (loosen counter clockwise) from the outlet port.
7. Remove the LP fuel jet (loosen counter clockwise) from the jet keeper port on the side of the regulator housing. Install this jet into the outlet port in the regulator casting.

### **NOTE:**

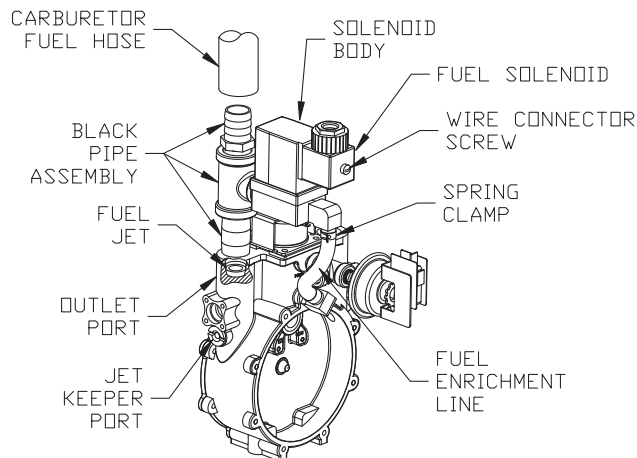
**The jet sizes are stamped on the individual jets. The larger jet size is used for running on NG.**

8. Install the previously removed NG jet into the jet keeper port on the side of the regulator housing.
9. Install the previously removed black pipe onto the outlet port of the demand regulator. Use pipe sealant on the pipe threads.
10. Reverse steps 1-4 in this procedure to reactivate the demand regulator.
11. Follow the instructions in the Control Panel section.

### **⚠ DANGER!**

**⚠ Serious injury, including death, or damage may occur if not configured properly. Please consult an Authorized Dealer with any questions.**

**Figure 6.1 — Reconfigure the Fuel System**



### **CONTROL PANEL**

The FUEL TYPE must be reconfigured in the control panel to finalize the conversion process. To access the fuel selection menu, select EDIT from the main control panel menu. Scroll through the prompts until FUEL TYPE is displayed. Press ENTER to select this field, then toggle the proper fuel type and press ENTER again to accept. The fuel conversion is now complete.

### **⚠ CAUTION!**

**⚠ Whenever the Generator's Fuel Regulator is converted from one Fuel type to the other, make sure to configure the Control Panel for the correct Fuel type.**

## ALTERNATOR AC LEAD CONNECTIONS

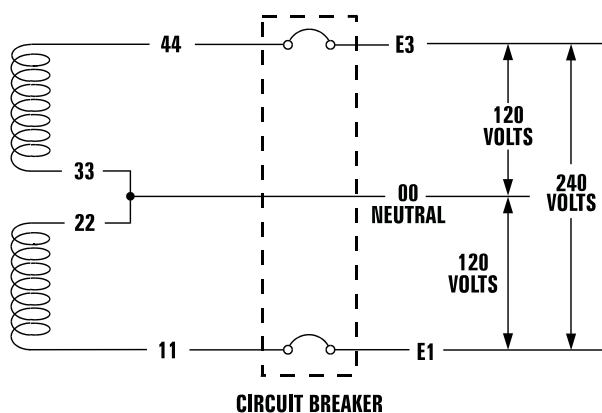
The electrical wires in the unit's AC connection (lower) panel should be installed according to the number of leads and the voltage/phase required for the application. The voltage and phase are described on the generator data label. The number of lead wires can be identified using the Specifications section and the power output rating on the generator data label. For example, if the generator produces 130kW, 277/480 Volt, 3-phase power, the generator has 12 alternator output leads. Figure 7.3 describes the stator power winding connection for the generator.

### FOUR-LEAD, SINGLE-PHASE STATOR

Four-lead alternators (see Figure 7.1) are designed to supply electrical loads with voltage code "A" (240V, 1-phase, 60 Hz). Electrical power is produced in the stator power windings. These windings were connected at the factory to the main circuit breaker as shown in Figure 7.1.

The rated voltage between each circuit breaker terminal is 240V. The rated voltage between each circuit breaker terminal and the neutral point 00 is 120V.

**Figure 7.1 — Four-lead, Single-phase Stator**



## ALTERNATOR POWER WINDING CONNECTIONS

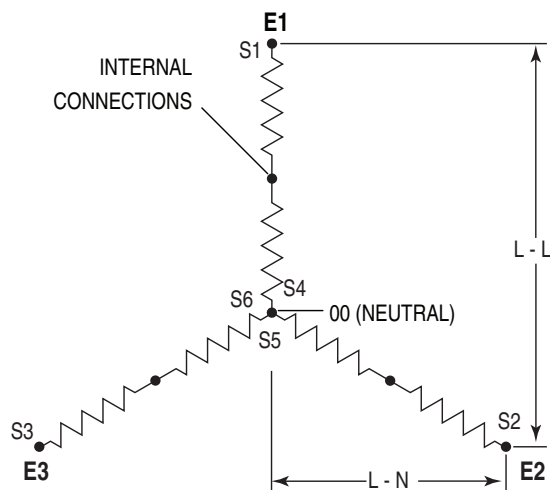
### 3-PHASE ALTERNATORS ("Y" CONFIGURATION)

The Stationary Emergency Generator is designed to supply 3-phase electrical loads. Electric power is produced in the alternator power windings. These windings were connected at the factory to the main circuit breaker with a "Y" configuration as shown in Figures 7.2 through 7.6.

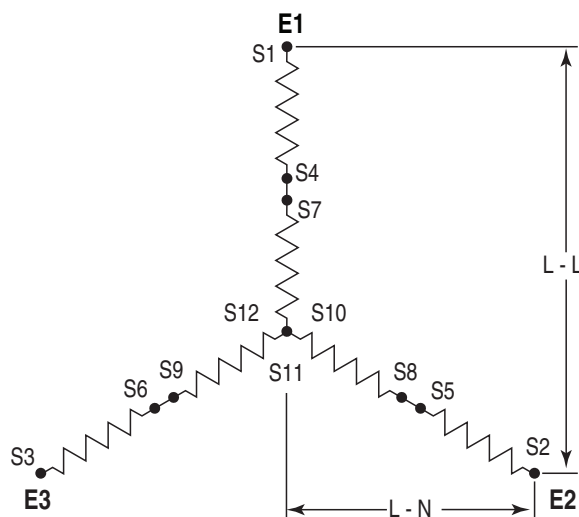
The rated voltage between circuit breaker terminals E1-E2, E1-E3 and E2-E3 is 480V, 208V or 600V depending on the model.

The rated voltage between each circuit breaker terminal and the neutral point 00 is 277V, 120V, or 346V depending on the model.

**Figure 7.2 — Stator Power Winding Connections - 3-phase, 277/480V (6 Lead)**

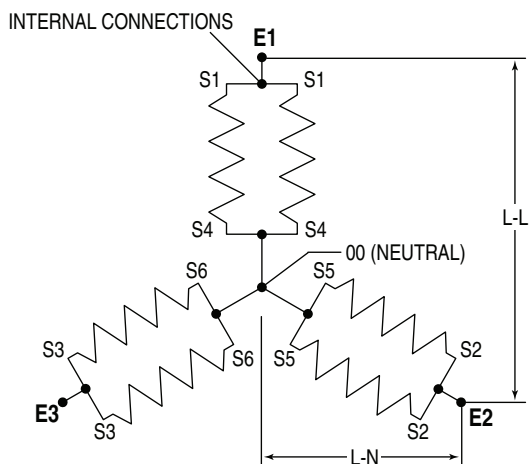


**Figure 7.3 — Stator Power Winding Connections - 3-phase, 277/480V (12 Lead)**

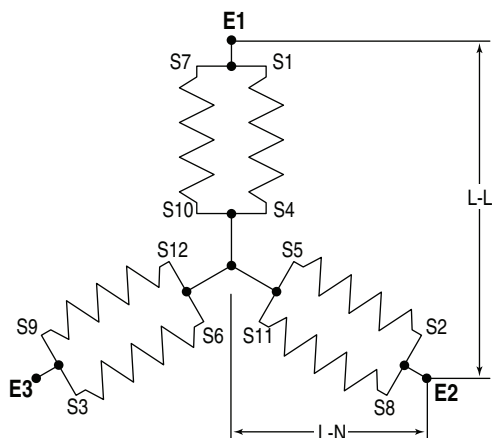


# General Information

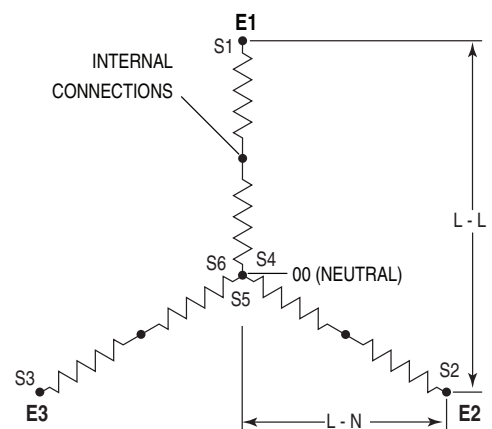
**Figure 7.4 — Stator Power Winding Connections - 3-phase, 120/208V (6 Lead)**



**Figure 7.5 — Stator Power Winding Connections - 3-phase, 120/208V (12 Lead)**



**Figure 7.6 — Stator Power Winding Connections - 3-phase, 346/600V (6 Lead)**



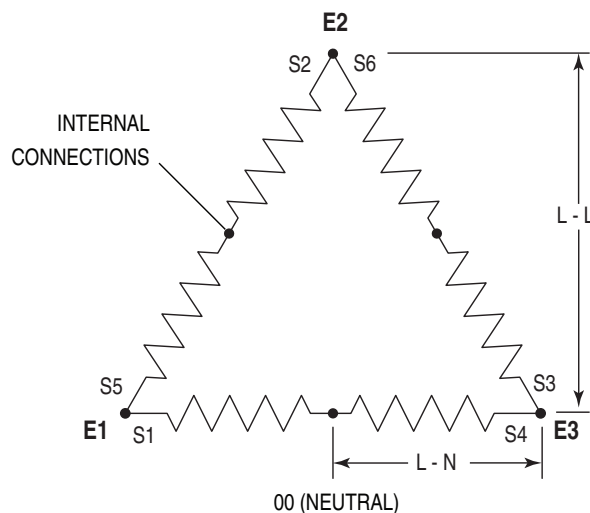
## 3-PHASE ALTERNATORS ("DELTA" CONFIGURATION)

The Stationary Emergency Generator is designed to supply 3-phase electrical loads. Electric power is produced in the alternator power windings. These windings were connected at the factory to the main circuit breaker with a "Delta" configuration as shown in Figures 7.7 and 7.8.

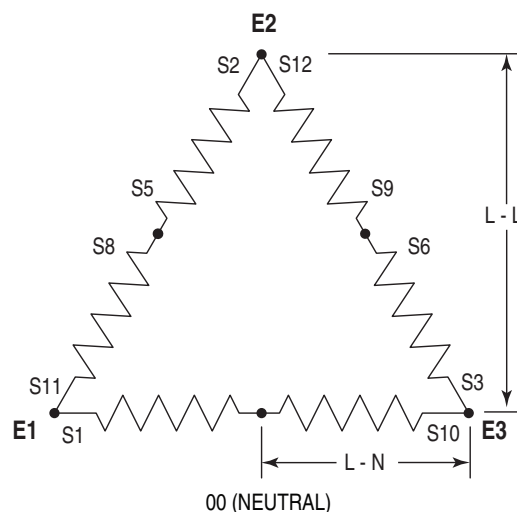
The rated voltage between circuit breaker terminals E1-E2, E1-E3 and E2-E3 is 240V.

The rated voltage between E1 or E3 and the neutral point 00 is 120V.

**Figure 7.7 — Stator Power Winding Connections - 3-phase, 120/240V (6 Lead)**



**Figure 7.8 — Stator Power Winding Connections - 3-phase, 120/240V (12 Lead)**



## CONTROL PANEL INTERFACE

### USING THE AUTO/OFF/MANUAL SWITCH

#### **⚠ WARNING!**

**⚠ With the switch set to AUTO, the engine may crank and start at any time without warning. Such automatic starting occurs when utility power source voltage droops below a preset level or during the normal exercise cycle. To prevent possible injury that might be caused by such sudden starts, always set the switch to OFF and remove the fuse before working on or around the generator or transfer switch. Then, place a “DO NOT OPERATE” tag on the generator panel and on the transfer switch.**

1. “AUTO” Position – Selecting this switch activates fully automatic system operation. It also allows the unit to automatically start and exercise the engine every seven days with the setting of the exercise timer (see the Setting the Exercise Timer section).
2. “OFF” Position – This switch position shuts down the engine. This position also prevents automatic operation.
3. “MANUAL” Position – Set the switch to MANUAL to crank and start the engine. Transfer to standby power will not occur unless there is a utility failure.

## ACTIVATE THE GENERATOR

When battery power is applied to the generator during the installation process, the controller will turn ON and the LCD screen will illuminate. However, the generator still needs to be activated before it will automatically run in the event of a power outage.

Activating the generator is a simple one time process that is guided by the controller screen prompts. Once the product is activated, the controller screen will not prompt you again, even if you disconnect the generator battery.

To obtain the activation code, record the generator serial number and log onto [www.activategen.com](http://www.activategen.com) or call 1-888-9ACTIVATE and follow the steps to retrieve the activation code.

After obtaining your activation code, please complete the following steps at the generator’s control panel in the Activation Chart on the following page.

#### **NOTE:**

**The generator will only run in manual until the passcode has been entered.**

Upon power up, this controller will go through a system self test which will check for the presence of utility voltage on the DC circuits. This is done to prevent damage if the installer mistakenly connects AC utility power sense wires into the DC terminal block. If utility voltage is detected, the controller will display a warning message and lock out the generator, preventing damage to the controller. Power to the controller must be removed to clear this warning.

Utility voltage must be turned on and present at the N1 and N2 terminals inside the generator control panel for this test to be performed and pass.

#### **NOTE:**

#### **DAMAGE CAUSED BY MISWIRING OF THE INTERCONNECT WIRES IS NOT WARRANTABLE!**

This test will be performed each time the controller is powered up.

Next, the user must enter the minimum settings to operate. These settings are current date and time and exercise day and time. The maintenance intervals will be initialized (i.e. started) the first time the clock is set. If the clock is never set at power up, the maintenance intervals will be reset every time power is applied.

If a subsequent power loss (loss of battery power) occurs the Installation assistant will operate upon power restoration. The self test routine will be run and then the customer will be required to re-enter the time and date, as this is not retained during a power loss. The unit will not require re-activation.

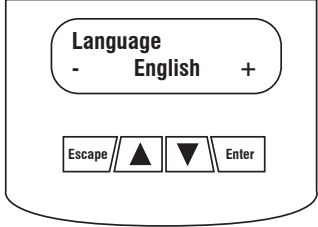
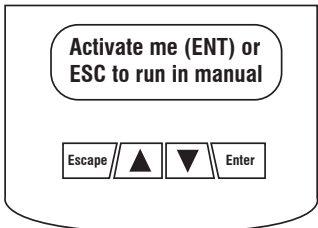


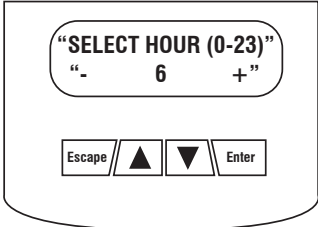
## DISPLAY INTERFACE MENUS

The LCD display is organized as detailed below:

- The “Home” page, this page is the default page which will be displayed if no keys are pressed for 30 seconds. This page normally shows the current Status message and the current date and time. The highest priority active Alarm and/or Warning will be automatically posted on this page as well as flashing the backlight when such an event is detected. In the case of multiple Alarms or Warnings, only the first message will be displayed. To clear an Alarm or Warning, see the Protection Systems section - Clear Alarm.
- The display backlight is normally off. If the user presses any key, the backlight will come on automatically and remain on for 30 seconds after the last key was pressed.
- The “Main Menu” page will allow the user to navigate to all other pages or sub-menus by using the Left/Right and Enter keys. This page can be accessed at any time with several presses of the dedicated Escape key. Each press of the Escape key takes you back to the previous menu until the main menu is reached. This page displays the following options: HISTORY; STATUS; EDIT; AND DEBUG. (See the Appendix - “Menu System”.)

# Control Panel

## ACTIVATION CHART

CHOOSE LANGUAGE		TROUBLESHOOTING
<p>Display Reads:</p> 	<p>Use ARROW keys to scroll to desired language. Press ENTER to select.</p>	<p>If the wrong language is chosen, it can be changed later using the “edit” menu.</p>
<p>Display Reads:</p> 	<p>Press ENTER to begin the activation process.</p>	<p>If ESCAPE is pressed instead of ENTER, your generator will only run in manual mode (for test purposes) and NOT ACTIVATED will be displayed. You will need to reconnect the battery and begin with Step 1.</p>
<p>Display Reads:</p> 	<p>If you do not have your activation code, go to <a href="http://www.activategen.com">www.activategen.com</a> or call 1-888-9ACTIVATE (922-8482). If you already have your activation code, wait 3-5 seconds for the next display.</p>	
ENTER ACTIVATION CODE (Passcode)		TROUBLESHOOTING
<p>Display Reads:</p> 	<p>Use ARROW keys to scroll and find the first number of your Activation Code. Press ENTER to select. Repeat this step until all digits have been entered. Use ESCAPE to correct previous digits.</p>	
<p>Display Reads:</p> 	<p>Activation is complete when all digits are entered above and your screen shows this display. Follow the controller prompts to continue setting the time function. Refer to your Owner’s Manual with questions.</p>	<p>What happens if “Wrong Passcode Try Again” appears? Re-enter the activation code. If a second attempt is unsuccessful, check the number against the code given on <a href="http://activategen.com">activategen.com</a>. If it is correct and the generator will not accept it, contact 1-888-9ACTIVATE (922-8482).</p>

# Control Panel

## INSTALLATION ASSISTANT

**Interconnect System Self Test Feature** (follow the on-screen prompts).

Upon power up, this controller will go through a system self test which will check for the presence of utility voltage on the DC circuits. This is done to prevent damage if the installer mistakenly connects AC utility power sense wires into the DC terminal block. If utility voltage is detected, the controller will display a warning message and lock out the generator, preventing damage to the controller. Power to the controller must be removed to clear this warning.

Utility voltage must be turned on and present at the N1 and N2 terminals inside the generator control panel for this test to be performed and pass.

### NOTE:

### **DAMAGE CAUSED BY MISWIRING OF THE INTERCONNECT WIRES IS NOT WARRANTABLE!**

This test will be performed each time the controller is powered up.

Upon first power up of the generator, the display interface will begin an installation assistant. The assistant will prompt the user to set the minimum settings to operate. These settings are simply: Current Date/Time and Exercise Day/Time. The maintenance intervals will be initialized when the exercise time is entered.

The exercise settings can be changed at any time via the "EDIT" menu (see Appendix, "Menu System").

If the 12 volt battery is disconnected or the fuse removed, the Installation Assistant will operate upon power restoration. The only difference is the display will only prompt the customer for the current Time and Date.

**IF THE INSTALLER TESTS THE GENERATOR PRIOR TO INSTALLATION, PRESS THE "ENTER" KEY TO AVOID SETTING UP THE EXERCISE TIME. THIS WILL ENSURE THAT WHEN THE CUSTOMER POWERS UP THE UNIT, HE WILL STILL BE PROMPTED TO ENTER AN EXERCISE TIME.**

## SETTING THE EXERCISE TIMER

This generator is equipped with an exercise timer. Once it is set, the generator will start and exercise every seven days, on the day of the week and at the time of day specified. During this exercise period, the unit runs for approximately 12 minutes and then shuts down. Transfer of loads to the generator output does not occur during the exercise cycle unless utility power is lost.

### **LOW SPEED EXERCISE**

The standard start sequence will be initiated.

- All 1800 rpm units will exercise at 1400 RPM
- All 3600 rpm units will exercise at 1800 RPM

If utility is lost during exercise the controller will do the following:

- Wait for the "line interrupt period" for utility to return. If utility returns within the "line interrupt period", continue to exercise at low RPM.

- If utility is still lost after the "line interrupt period", run the engine up to normal RPM and transfer the load. At this time the controller will exit the exercise routine and assume full automatic operation.

## USER ADJUSTABLE SETTINGS

Setting	Factory Default	Minimum Setting	Maximum Setting	Increment
Exercise time	2 pm	00:00 (12 am)	23:59 (11:59 pm)	1 min
Exercise day	Wed	Sun	Sat	1 day
Current Time	12 am	00:00 (12 am)	23:59 (11:59 pm)	1 min
Current Day	Sun	Sun	Sat	1 day
Current Month	Jan	Jan	Dec	1 month
Current Year	2008	2008	2100	1 year
Language	English	French	Spanish	N/A
Contrast	80%	0%	100%	1%

## FUEL CONVERSION

For fuel conversion steps, refer to the GenSpec section, RECONFIGURING THE FUEL SYSTEM.

## OPERATION

This system is intended to supply standby power in the event of a utility failure. The control system will monitor the utility voltage to determine if stand-by power is required. Should the utility voltage fail, the generator will start and run normally, detaching from the utility and supplying the customer load from the generator. When utility power returns, the controller will re-transfer the customer load back to utility and shut down the generator.

### **AUTOMATIC TRANSFER OPERATION**

To select automatic operation, do the following:

1. Make sure the transfer switch main contacts are set to their UTILITY position, i.e., loads connected to the utility power source.
2. Be sure that normal UTILITY power source voltage is available to transfer switch terminal lugs N1 and N2 (Refer to the Electrical Data section).
3. Set the generator's AUTO/OFF/MANUAL switch to AUTO.
4. Set the generator's main circuit breaker to its ON (or CLOSED) position.

With the preceding steps complete, the generator will start automatically when utility source voltage drops below a preset level. After the unit starts, loads are transferred to the standby power source. Refer to the Sequence of Automatic Operation section.



## **SEQUENCE OF AUTOMATIC OPERATION**

Initial Conditions: Generator in Auto ready to run, load being supplied by the Utility Source through the transfer switch.

1. When the utility voltage fails (falls below 60% of nominal), a 10-30 second (programmable) "line interrupt" delay timer is started. The factory set time delay is 10 seconds. If at the end of the line interrupt time the utility voltage is above 60% the engine will not crank. If the utility voltage is still below the 60% of nominal at the end of the line interrupt time, the unit will crank and start. If the unit cranks for more than 10 seconds and the utility voltage rises above 80% of nominal (programmed pickup voltage) and the unit has not started, the crank cycle will abort.
2. As soon as the unit starts a 5 second "warm-up" timer is initiated. When the warm-up timer expires the control will transfer the load to the generator (through the RTS switch) if the utility voltage is less than 80% of nominal. If the utility voltage is greater than the 80% of nominal at the end of the warm-up time the load will not be transferred to the generator and a one minute low-speed cool down period will start. At the end of the one minute cool down period the generator will stop.
3. Once the unit is running and the switch has transferred the load to the generator the unit will monitor utility voltage. When utility voltage returns (above the programmable pickup voltage, normally 80% of nominal), a 15 second "Return to Utility" timer will start. At the end of the return to utility time, if the utility voltage is still above the pickup voltage, the unit will transfer the load back to the utility source and run the unit through a one minute cool down period. When the cool down period is over the unit will shut down and be ready for the next outage.
4. If during the cool down period utility voltage should fall below 60% of nominal for the line interrupt delay period, the unit will transfer the load back to the generator and continue to monitor the utility.

## **CRANK CYCLES AND OVERCRANK SHUTDOWN**

If the unit fails to start during a cranking period it will display the Overcrank Shutdown Alarm. The system will control the cranking cycles as follows:

The first crank cycle is a 16 second crank time followed by a 7 second rest. The next 5 cycles will be 7 seconds of cranking time each followed by a 7 second rest time.

If the unit fails to start by the end of the 6 crank/rest cycles the Overcrank Shutdown Alarm will display and the unit will not attempt to crank until the alarm is reset.

## **AUTO START**

This unit is designed to automatically start in the event of a utility failure or brown out condition. Brown out is defined as utility voltage less than 60% nominal, while utility is considered good when it is restored to at least the pickup value, 80% of nominal. These levels are fixed. The "Line Interrupt period" is an adjustable parameter by the dealer. If 2-wire start mode is activated, the unit will start when 2-wire start is active.

## **MANUAL START**

Allows the user to start and run the generator manually.

Transfer of the load to the generator will occur if utility is lost while the unit is running in the manual mode (only if activated).

## **ALARM AND WARNING MESSAGES**

Alarms are defined as "Latching" which means they must be cleared before the alarm message on the screen will clear. They can be of type "Shutdown" or not and are logged in the alarm log. Alarms are all annunciated on the display).

Warnings are "Non Latching" meaning the message automatically clears when the warning condition goes away. Warnings can not be of type "Shutdown" but they are logged in the alarm log. Warnings are all annunciated on the display.

### **LOW OIL PRESSURE SHUTDOWN ALARM**

There is a 10 second delay before oil pressure is monitored.

### **HIGH COOLANT TEMPERATURE SHUTDOWN ALARM**

There is a 10 second delay before engine temperature is monitored.

Once running there is a 1/4 second delay before shut down. The limit is set at 125° C or 257° F.

### **OVERCRANK SHUTDOWN ALARM**

Occurs if the engine has not started within the specified crank cycle.

### **OVERSPEED SHUTDOWN ALARM**

Warning indicator is measured and calculated by the microprocessor. Overspeed is defined as +20% of nominal engine speed for 3 seconds, or +25% immediate.

Nominal engine speed = 60.0 Hz

### **RPM SENSOR FAILURE SHUTDOWN ALARM**

During cranking: If the board does not see a valid RPM signal within four (4) seconds of cranking it will shut down and lock out on RPM sensor loss.

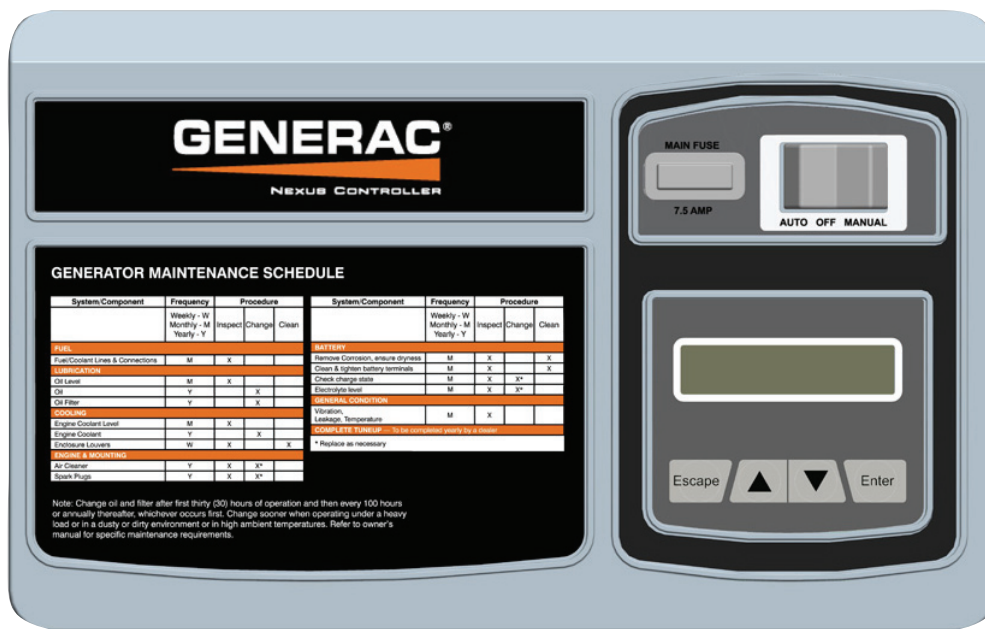
During running: If the RPM signal is lost for one full second the board will shut the engine down, wait 15 seconds, then re-crank the engine if in AUTO, it will not re-crank in MANUAL.

If no RPM signal is detected within the first four (4) seconds of cranking, the control board will shut the engine down and latch out on RPM sensor loss.

If the RPM signal is detected the engine will start and run normally. If the RPM signal is subsequently lost the control board will try two more re-cranks before latching out and flashing the RPM Sensor Failure message (if it is in AUTO).

# Control Panel

Figure 1 – Generator Control Panel



### GENERATOR MAINTENANCE SCHEDULE

System/Component	Frequency	Procedure		System/Component	Frequency	Procedure	
	Weekly - W Monthly - M Yearly - Y	Inspect	Change / Clean		Weekly - W Monthly - M Yearly - Y	Inspect	Change / Clean
<b>FUEL</b>				<b>BATTERY</b>			
Fuel/Coolant Lines & Connectors	M	X		Remove Corrosion, remove dryness	M	X	X
Generator Oil	M	X	X	Clean & replace battery terminals	M	X	X
Oil Level	M	X		Check charge state	M	X	X*
Oil	Y		X	Electrolyte level	M	X	X*
Oil Filter	Y		X	<b>GENERAL CONDITIONS</b>			
<b>COOLING</b>				Vibration, Load, Temperature	M	X	
Engine Coolant Level	M	X		<b>COMPLETE TUNEUP</b> * To be performed every 100 hours			
Engine Coolant	Y		X	* Replace as necessary			
Intake Louvers	W	X	X				
<b>FILTERS &amp; MOUNTING</b>							
Air Charge	Y	X	X*				
Spark Plugs	Y	X	X*				

Note: Change oil and filter after first thirty (30) hours of operation and then every 100 hours or annually thereafter, whichever occurs first. Change sooner when operating under a heavy load or in a dusty or dirty environment or in high ambient temperatures. Refer to owner's manual for specific maintenance requirements.

## UNDER-FREQUENCY SHUTDOWN ALARM

After starting, if the generator stays under frequency for more than 30 seconds, it will shutdown.

## LOW BATTERY ALARM

While running if the average battery voltage falls below 11.9 volts for one (1) minute, the low battery alarm will be displayed.

## LOW BATTERY WARNING

The microprocessor will continually monitor the battery voltage and display the Low Battery Voltage message if the battery voltage falls below 12.2 Volts for one (1) minute.

No other action is taken on a low battery warning condition. The warning will automatically clear if the battery voltage rises above 12.2 volts.

### NOTE:

**The battery sentinel is a separate feature that monitors battery condition.**

## LOW COOLANT LEVEL ALARM

This is a shutdown alarm. The sensor will be continuously monitored. If an error condition is seen for five (5) consecutive seconds, the alarm will be displayed.

## MISSING CAM PULSE ALARM

This is a shutdown alarm. The alarm will activate after five (5) seconds of continuously missing cam pulses.

## MISSING CRANK PULSE ALARM

This is a shutdown alarm. The alarm will activate after 12 consecutive revs where crank pulses are missing.

## LOW FUEL PRESSURE WARNING

Fuel pressure is monitored by a digital sensor with a fixed setpoint of below five (5) inches water column.

## GOVERNOR SENSOR FAULT ALARM

The governor position is monitored by an analog feedback signal. If the throttle position is seen outside of the normal operating range, a shutdown alarm is displayed. If the throttle is commanded to move, and no movement is seen, a shutdown alarm is displayed.

## WIRING ERROR ALARM

When power is first applied to the controller, the software will perform a check on the wiring of the transfer output, and ensure it does not have high voltage on the wire. If this is the case, it will signal a miswire alarm and will not run. The test can be skipped by use of the escape key.

## UNDERVOLTAGE ALARM

If the generator voltage falls below 60% for >5 seconds, an alarm will be issued.

# Control Panel

## **OVERVOLTAGE ALARM**

If the generator voltage rises above 110% for >3 seconds, an alarm will be issued.

If the generator voltage rises above 130% for >0.2 seconds, an alarm will be issued.

## **INTERNAL FAILURE SHUTDOWN ALARM**

Any internal failure that can be detected such as corrupted firmware will cause this shutdown alarm. This alarm cannot be cleared.

## **CANBUS ALARM**

Where applicable, if the Canbus communications link fails to communicate, a “Canbus alarm” will be generated. This only applies to systems with external ignition modules. The alarm may be generated if:

1. The physical link is broken.
2. The ignition module fails or resets.
3. The Nexus module fails or resets.

## **IGNITION ALARM**

When an ignition alarm occurs, a generic message “Ignition Fault” will be displayed as the fault code.

## **MAINTENANCE WARNING**

When a maintenance period expires, a warning message will be posted. The warning can be reset by hitting the Enter key. Resetting will clear the warning and reset the maintenance counters for the condition annunciated. The history log will reflect the maintenance warning.

## **ALARM CANCEL**

When the generator is shut down due to a latching alarm, the Auto /Off/ Manual switch must be set to the off position and the ENTER key pressed to unlatch any active fault and clear the corresponding fault alarm message.

## **COMMON ALARM RELAY**

The common alarm relay will be activated if there is a shutdown alarm. It will not activate on warnings or indicate that the Auto/Off/ Manual switch is in the OFF position. The OFF position will clear the alarms and the relay. The relay will not be used to indicate a generator is not activated.

## **MAINTENANCE ALERTS**

Maintenance alerts will be provided for these conditions (see the Maintenance Alert Chart).

### **SERVICE SCHEDULE ‘A’**

Inspect Accessory drive alert	1yr /100hrs
Coolant change & flush	1yr /100hrs
Inspect spark plugs alert	1yr /100hrs
Change oil & filter alert	1yr /100hrs
Inspect battery alert	1yr /100hrs
Change / Inspect air filter alert	1yr /100hrs

### **SERVICE SCHEDULE ‘B’**

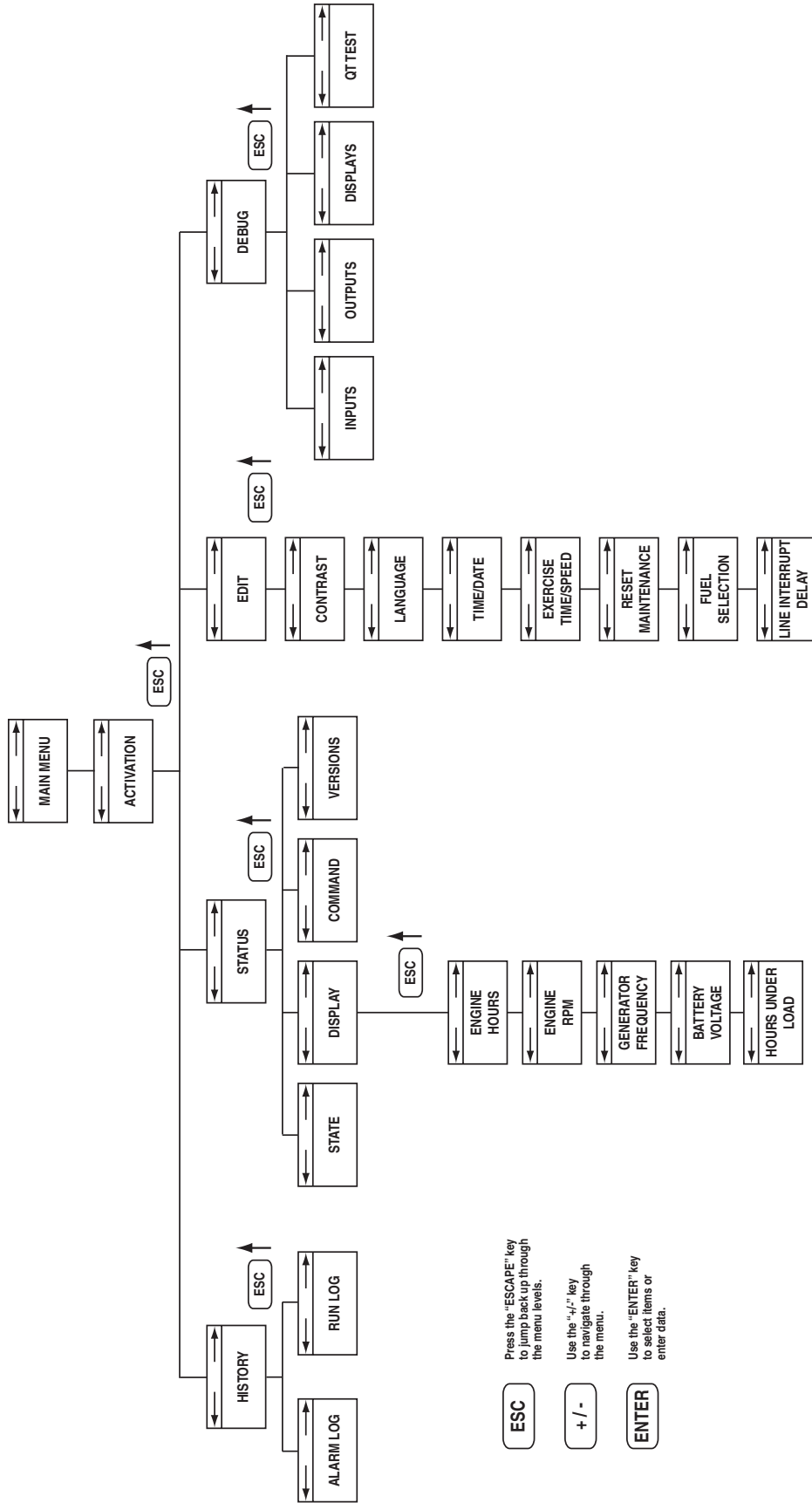
Change / Inspect spark plugs alert	2yr/ 250hr
------------------------------------	------------

## **MAINTENANCE ALERT CHART**

CONDITION	1.6 CHERY	2.4/1800 MITSU	2.4/3600 MITSU	4.2 FORD
Change oil & filter alert	3mo/30hrs break-in 1yr/100hrs	3mo/30hrs break-in 1yr/100hrs	3mo/30hrs break-in 1yr/100hrs	3mo/30hrs break-in 1yr/100hrs
Inspect/clean air inlet & exhaust alert	3mo/30hrs break-in 6mo/50hrs	3mo/30hrs break-in 6mo/50hrs	3mo/30hrs break-in 6mo/50hrs	3mo/30hrs break-in 6mo/50hrs
Change / Inspect air filter alert	1yr/100hr	1yr/100hr	1yr/100hr	1yr/100hr
Inspect spark plugs alert	1yr /100hrs	1yr /100hrs 1yr /100hrs	1yr /100hrs	1yr /100hrs
Change / Inspect spark plugs alert	2yr/ 250hr	2yr/ 250hr	2yr/ 250hr	2yr/ 250hr
Inspect Accessory drive alert	3mo/30hrs break-in 1yr /100hrs	3mo/30hrs break-in 1yr /100hrs	3mo/30hrs break-in 1yr /100hrs	3mo/30hrs break-in 1yr /100hrs
Coolant change & flush	1yr /100hrs	1yr /100hrs	1yr /100hrs	1yr /100hrs
Inspect battery alert	1yr /100hrs	1yr /100hrs	1yr /100hrs	1yr /100hrs

# MENU SYSTEM

## Control Panel



Press the "ESCAPE" key to jump back up through the menu levels.



Use the "+/-" key to navigate through the menu.



Use the "ENTER" key to select items or enter data.



## STATIONARY EMERGENCY GENERATOR CONTROL AND OPERATION

Refer to the appropriate control panel operator's manual for this unit.

### OPERATING UNIT WITH MANUAL TRANSFER SWITCH

If the Stationary Emergency Generator was installed in conjunction with a transfer switch capable of manual operation only, the following procedure applies. A manually operated transfer switch is one that will not provide automatic start-up and does not include an intelligence circuit.

#### ENGINE START-UP AND TRANSFER

For additional information, refer to the applicable control panel manual for this unit, as well as any literature pertaining to the specific transfer switch.

#### **⚠ DANGER!**

**⚠ The Maintenance Disconnect Switch and the AUTO/OFF/MANUAL switches (if so equipped) must be set properly, or the generator will crank and start as soon as the utility power to the transfer switch is turned off. Refer to applicable control panel and transfer switch manuals for more information.**

**⚠ Do not proceed until certain that utility source voltage is available to the transfer switch and the transfer switch main contacts are set to UTILITY.**

**⚠ Do not attempt manual operation until all power supplies to the transfer switch have been positively turned off, or extremely dangerous - possibly lethal - electrical shock will result.**

**⚠ Transfer switch enclosure doors should be kept closed and locked. Only authorized personnel should be allowed access to the transfer switch interior. Extremely high and dangerous voltages are present in the transfer switch.**

In order to transfer load from the utility source to the generator, follow these directions:

- Turn OFF or disconnect the utility power circuit to the transfer switch, using the means provided (such as the utility source main line circuit breaker).
- Set the transfer handle to its UTILITY (NORMAL) position with load circuits connected to the utility power supply.
- Set the generator's main line circuit breaker to its OFF (or OPEN) position.
- Start the generator.

#### **⚠ CAUTION!**

**⚠ Do not crank the engine continuously for longer than 30 seconds, or the heat may damage the starter motor.**

- Let engine stabilize and warm up.
- Check all applicable instrument and gauge readings. When certain that all readings are correct, move the transfer switch manual handle to the STANDBY (or EMERGENCY STANDBY) position, i.e., load circuits supplied by the generator.
- Set the generator's main line circuit breaker to its ON (or CLOSED) position.
- Load circuits are now powered by the generator.

#### RETRANSFER AND SHUTDOWN

For additional information, refer to the applicable control panel manual for this unit, as well as any literature pertaining to the specific transfer switch.

To transfer the load back to the utility power source and shut down the generator, follow these directions:

- Set the generator's main line circuit breaker to its OFF (or OPEN) position.
- Manually move the transfer switch handle to its UTILITY (NORMAL) position, i.e., load circuits connected to the utility.
- Turn ON the utility power supply to the transfer switch, using the means provided (such as the utility power source main line circuit breaker).
- Let the generator run at no-load for a few minutes to stabilize internal temperatures.
- Shut down the generator.

### OPERATING UNIT WITH AUTOMATIC TRANSFER SWITCH

If the Stationary Emergency Generator has been installed with an automatic transfer switch, the engine may be started and stopped automatically or manually.

#### NOTE:

**Refer to the applicable manual for your transfer switch and to "Transfer Switch Start Signal Connections". In addition, please note the dangers under "Engine Start-up and Transfer."**

## GENERAL MAINTENANCE

### ⚠ WARNING!

⚠ Before working on the Stationary Emergency Generator, ensure the following:

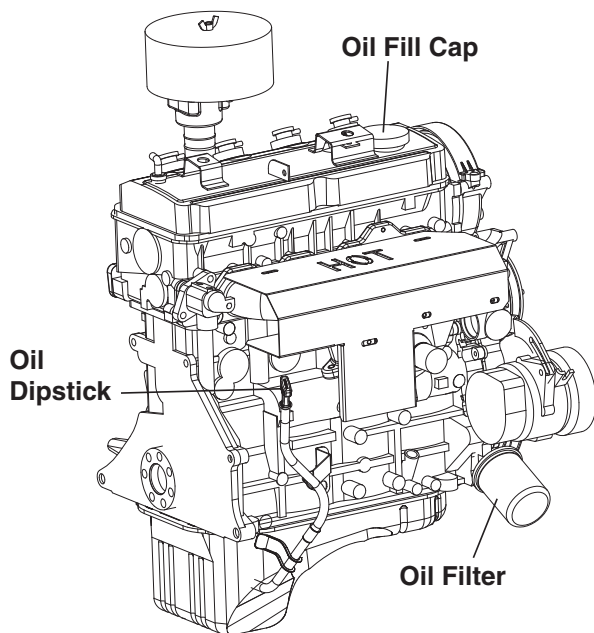
- The AUTO/OFF/MANUAL switch is in the OFF position.
- The control panel fuse has been removed from the control box.
- The 120VAC supply to the battery charger is switched OFF.
- The negative battery cable has been removed.

## CHECK ENGINE OIL

Check engine crankcase oil level (Figure 10.1) according to the Service Schedule.

- Remove oil dipstick and wipe dry with a clean, lint-free cloth.
- Install oil dipstick, then remove again.
- Oil should be between FULL and ADD marks.
- If oil level is below the dipstick ADD mark, remove oil fill cap-. Add the recommended oil to bring oil level up to the FULL mark. DO NOT FILL ABOVE THE "FULL" MARK. See "Engine Oil Recommendations" for recommended oils.

Figure 10.1 - Oil Dipstick and Oil Fill Cap



## CHANGING ENGINE OIL

### ⚠ CAUTION!

⚠ Hot oil may cause burns. Allow engine to cool before draining oil. Avoid prolonged or repeated skin exposure with used oil. Thoroughly wash exposed areas with soap.

Refer to the Service Schedule for engine oil and filter change frequencies.

Drain the oil while the engine is still warm from running. This means warm up the engine, shut it down and drain immediately as follows:

1. Remove the drain hose from its retaining clip or cut the zip-tie securing the oil drain hose.
2. Loosen and remove OIL DRAIN HOSE CAP. Drain oil completely into suitable container.
3. When all oil has drained, install and tighten OIL DRAIN HOSE CAP and secure drain hose with a new zip-tie, or place the hose in its retaining clip.
4. Turn OIL FILTER (Figure 10.1) counterclockwise and remove. Properly dispose of old filter.
5. Apply light coating of new engine oil to seal of new oil filter.-Install FILTER and tighten by hand only. DO NOT OVER TIGHTEN.
6. Remove OIL FILL CAP and add recommended oil. Crankcase oil capacity is listed in the "Specifications" section.

### ⚠ CAUTION!

⚠ After refilling the crankcase with oil, always check oil level on dipstick. NEVER OPERATE ENGINE WITH OIL BELOW THE DIPSTICK "ADD" MARK.

7. Start engine and check for oil leaks.
8. Shut OFF engine and wait 10 minutes for the oil to settle down into the oil pan. Recheck oil level on dipstick. DO NOT fill above the dipstick "FULL" mark.
9. Dispose of used oil at a proper collection center.

## COOLING INTAKE/OUTLET

Air intake and outlet openings in the generator compartment must be open and unobstructed for continued proper operation. This includes such obstructions as high grass, weeds, brush, leaves and snow.

Without sufficient cooling and ventilating air flow, the engine/generator quickly overheats, which causes it to shut down. (See the installation diagram.)

### ⚠ WARNING!

⚠ The exhaust system parts from this product get extremely hot and remains hot after shutdown. High grass, weeds, brush, leaves, etc. must remain clear of the exhaust. Such materials may ignite and burn from the heat of the exhaust system.

## INSPECT COOLING SYSTEM

- Inspect engine cooling system. See the Service Schedule.
- Check hoses for damage, deterioration, leaks, etc. Correct any discrepancies found.
- Check hose clamps for tightness.

# Maintenance

## **ENGINE COOLANT**

Check coolant level in coolant recovery bottle. See the Specifications and Service Schedule sections.

- Add recommended coolant mixture as necessary.
- Periodically remove radiator pressure cap (only when engine has cooled down) to make sure the coolant recovery system is functioning properly. Coolant should be at bottom of radiator filler neck. If coolant level is low, inspect gasket in radiator pressure cap. Replace cap, if necessary. To have pressure cap tested, contact a Service Facility. Inspect cooling system and coolant recovery system for leaks.

## **COOLANT CHANGE**

Every year, have a service facility drain, flush and refill the cooling system. See the Specifications and Service Schedule for cooling system recommendations.

## **OVERLOAD PROTECTION FOR ENGINE DC ELECTRICAL SYSTEM**

Engine cranking, start up and running are controlled by a solid state Engine Controller circuit board. Battery voltage is delivered to that circuit board via the control panel fuse. This overcurrent protection device will open if the circuit is overloaded.

### **⚠ CAUTION!**

- ⚠ If a circuit breaker opens or a fuse element melts, find the cause of the overload before resetting the circuit breaker or replacing the fuse.**

## **EXERCISE SYSTEM**

Starts the Stationary Emergency Generator engine once every seven days and lets it run for 12 minutes.

## **PERFORM VISUAL INSPECTION**

Complete a thorough visual inspection of the entire engine-generator monthly. Look for obvious damage, loose, missing or corroded nuts, bolts and other fasteners. Look for fuel, oil or coolant leaks.

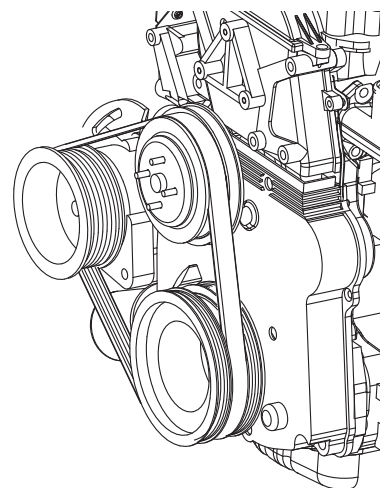
## **INSPECT EXHAUST SYSTEM**

Inspect the exhaust system at least once every year. Check all exhaust system pipes, mufflers, clamps, etc. for condition, tightness, leaks, security, damage.

## **CHECK FAN BELT**

- Inspect fan belts every year. Replace any damaged, deteriorated, worn or otherwise defective belt.
- Check fan belt tension. Thumb pressure, exerted midway between pulleys, should deflect about 3/8 to 5/8 of an inch. Adjust belt tension as required.
- Check fan belt alignment (see Figure 10.3).

**Figure 10.3 – Fan Belt**



## **INSPECT ENGINE GOVERNOR**

Visually inspect electronic governor.

### **⚠ DANGER!**

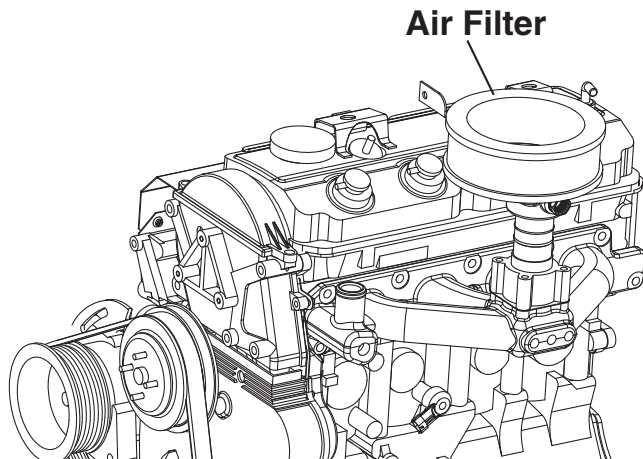
- ⚠ Do not attempt to adjust the governor. Only qualified service facilities should adjust the governor. Excessively high operating speeds are dangerous and increase the risk of personal injury. Low speeds impose a heavy load on the engine when adequate engine power is not available and may shorten engine life. Correct rated frequency and voltage are supplied only at the proper governed speed. Some connected electrical load devices may be damaged by incorrect frequency and/or voltage. Only qualified service technicians should adjust the governed speed.**

## **CHANGING THE ENGINE AIR FILTER**

To replace the engine air filter, remove the air filter cover and replace the air filter making sure it is positioned properly before reattaching the cover (Figure 10.4).

See the Service Schedule for air filter maintenance.

Figure 10.4 – Engine Air Filter



## SPARK PLUGS

Reset the spark plug gap or replace the spark plugs as necessary.

1. Clean the area around the base of the spark plugs to keep dirt and debris out of the engine. Clean by scraping or washing using a wire brush and commercial solvent. Do not blast the spark plugs to clean.
2. Remove the spark plugs and check the condition. Replace the spark plugs if worn or if reuse is questionable. See the “Service Schedule” section for recommended inspection.
3. Check the spark plug gap using a wire feeler gauge. See the Specifications section for the required spark plug gap.

## BATTERY MAINTENANCE

The battery should be inspected per the Service Schedule section. The following procedure should be followed for inspection:

1. Inspect the battery posts and cables for tightness and corrosion. Tighten and clean as necessary.
2. Check the battery fluid level of unsealed batteries and, if necessary, fill with DISTILLED WATER ONLY. DO NOT USE TAP WATER IN BATTERIES.
3. Have the state of charge and condition checked. This should be done with an automotive-type battery hydrometer.

### **⚠ DANGER!**

**⚠ Storage batteries give off explosive hydrogen gas. This gas can form an explosive mixture around the battery for several hours after charging. The slightest spark can ignite the gas and cause an explosion. Such an explosion can shatter the battery and cause blindness or other injury. Any area that houses a storage battery must be properly ventilated. Do not allow smoking, open flame, sparks or any spark producing tools or equipment near the battery.**

**⚠ Battery electrolyte fluid is an extremely corrosive sulfuric acid solution that can cause severe burns. Do not permit fluid to contact eyes, skin, clothing, painted surfaces, etc. Wear protective goggles, protective clothing and gloves when handling a battery. If fluid is spilled, flush the affected area immediately with clear water.**

**⚠ Do not use any jumper cables or booster battery to crank and start the generator engine. If the battery has completely discharged, remove it from the generator for recharging.**

### **⚠ WARNING!**

**⚠ Be sure the AUTO/OFF/MANUAL switch is set to the OFF position, before connecting the battery cables. If the switch is set to AUTO or MANUAL, the generator can crank and start as soon as the battery cables are connected.**

**⚠ Be sure the 120VAC power supply to the battery is turned OFF, or sparking may occur at the battery posts as the cables are attached and cause an explosion.**

## BATTERY REPLACEMENT

### NOTE:

**Unit DOES NOT include battery.**

When supplying or replacing the battery, the recommended number and type of battery is listed in the Specifications Section.

### NOTE:

**The BCI number should be located directly on the battery.**

## BATTERY FLUID

Check battery electrolyte fluid based on the Service Schedule. Fluid should cover separators in all battery cells. If fluid level is low, add distilled water to cover tops of separators. DO NOT USE TAP WATER IN BATTERY.

## CLEANING THE STATIONARY EMERGENCY GENERATOR

Keep the generator as clean and as dry as possible. Dirt and moisture that accumulates on internal generator windings have an adverse effect on insulation resistance.

Periodically clean generator exterior surfaces. A soft brush may be used to loosen caked on dirt. Use a vacuum system or dry, low pressure air to remove any accumulations of dirt. The generator is housed inside an all-weather enclosure, clean the enclosure with a soft, damp cloth or sponge and water.

Once each year have the generator cleaned and inspected by a Service Dealer. That dealer will use dry, low pressure air to clean internal windings.

Finally, have the insulation resistance of stator and rotor windings checked. If insulation resistances are excessively low, the generator may require drying.



# Service Schedule

## SERVICE SCHEDULE

System / Component	Frequency	Procedure		
		Inspect	Change	Clean
	Weekly - W Monthly - M Yearly - Y			
<b>Fuel</b>				
Fuel Lines & Connections	M	X		
<b>Lubrication</b>				
Oil Level	M	X*		
Oil	Y		X**	
Oil Filter	Y		X**	
<b>Cooling</b>				
Engine Coolant Lines & Connections	M	X		
Engine Coolant Level	M	X		
Engine Coolant	Y		X	
Enclosure Louvers	W	X		X
<b>Engine</b>				
Air Cleaner	Y	X	X***	
Spark Plugs	Y	X	X***	
<b>Battery</b>				
Remove Corrosion, Ensure Dryness	M	X		X
Clean & Tighten Battery Terminals	M	X		X
Check Charge State	M	X	X***	
Check Electrolyte Level	M	X	X***	
<b>General Condition</b>				
Vibration, Noise, Leakage, Temperature	M	X		
<b>Generator System</b>				
Complete Tune-up and System Inspection	Y	To be completed by an Authorized Service Dealer.		
<b>Footnotes</b>				
* Inspect the oil level monthly or every 12 hours during continuous operation.				
** Change oil and oil filter after the first 30 hours of operation and then every 100 hours or annually thereafter, whichever occurs first. Change sooner when operating under heavy load or in a dusty or dirty environment or in high ambient temperatures.				
*** Replace as necessary.				

# Troubleshooting

## TROUBLESHOOTING GUIDE

<b>PROBLEM</b>	<b>CAUSE</b>	<b>CORRECTION</b>
Engine won't crank.	<ol style="list-style-type: none"> <li>1. Control panel 7.5 amp fuse blown.</li> <li>2. Loose or corroded or defective battery cables.</li> <li>3. Defective starter contactor.</li> <li>4. Defective starter motor.</li> <li>5. Dead or Defective Battery.</li> </ol>	<ol style="list-style-type: none"> <li>1. Replace fuse.*</li> <li>2. Tighten, clean or replace battery cables as necessary.*</li> <li>3. Replace contactor.*</li> <li>4. Replace starter motor.*</li> <li>5. Remove, change or replace battery.*</li> </ol>
Engine cranks but won't start.	<ol style="list-style-type: none"> <li>1. Out of fuel.</li> <li>2. Fuel solenoid (FS) is defective</li> <li>3. Spark plugs defective.</li> </ol>	<ol style="list-style-type: none"> <li>1. Replenish fuel/turn on fuel valve.</li> <li>2. Replace solenoid.*</li> <li>3. Clean, regap or replace plugs.</li> </ol>
Engine starts hard, runs rough.	<ol style="list-style-type: none"> <li>1. Air cleaner plugged or damaged.</li> <li>2. Defective spark plugs.</li> <li>3. Fuel pressure incorrect.</li> <li>4. Insufficient fuel supply.</li> <li>5. Fuel system set to wrong fuel type.</li> </ol>	<ol style="list-style-type: none"> <li>1. Clean or replace as needed.</li> <li>2. Clean, regap or replace plugs.</li> <li>3. Confirm fuel pressure to regulator is as recommended in SPECIFICATIONS.*</li> <li>4. Confirm fuel pressure to regualtor is as recommended in SPECIFICATIONS.*</li> <li>5. Reconfigure the fuel system. (See RECONFIGURING THE FUEL SYSTEM in manual.*</li> </ol>
Engine starts then shuts down.	<ol style="list-style-type: none"> <li>1. Engine oil level is low.</li> <li>2. Engine is overheated.</li> <li>3. Defective Low Oil Pressure Switch</li> <li>4. Defective Coolant Temperature Switch</li> <li>5. Defective Control Module circuit board.</li> <li>6. Coolant Level is Low.</li> <li>7. Defective Low Coolant Level Switch</li> </ol>	<ol style="list-style-type: none"> <li>1. Check oil and add oil as needed.</li> <li>2. Check cooling system for leaks.</li> <li>3. Replace switch.*</li> <li>4. Replace switch.*</li> <li>5. Replace board.*</li> <li>6. Repair leak - Add coolant.</li> <li>7. Replace Switch.*</li> </ol>
AUTO/OFF/MANUAL Switch at OFF, engine continues to run.	<ol style="list-style-type: none"> <li>1. Defective AUTO/OFF/MANUAL switch</li> <li>2. Defective Control Module circuit board</li> </ol>	<ol style="list-style-type: none"> <li>1. Replace board.*</li> <li>2. Replace board.*</li> </ol>
No AC output from generator.	<ol style="list-style-type: none"> <li>1. Main line circuit breaker is tripped/open.</li> <li>2. Generator internal failure.</li> <li>3. Thermal circuit breaker open.</li> </ol>	<ol style="list-style-type: none"> <li>1. Reset to ON/CLOSED.</li> <li>2. *</li> <li>3. Auto-reset - Wait 5 min. and attempt restart.</li> </ol>

**\*Contact the nearest Dealer for assistance.**

# Warranty

## United States Environmental Protection Agency Warranty Statement Warranty Rights, Obligations and Coverage

The United States Environmental Protection Agency (EPA) and Generac Power Systems, Inc. (Generac), are pleased to explain the Emission Control System Warranty on your new stationary emergency engine. If during the warranty period, any emission control system or component on your engine is found defective in materials or workmanship Generac will repair your engine at no cost to you for diagnosis, replacement parts and labor provided it be done by an Authorized Warranty Service Facility. Your emission control system may include parts such as the fuel metering, ignition, and exhaust systems and other related emission related components listed below. Generac will warrant the emissions control systems on your 2009 and later model year engines provided there has been no abuse, neglect, unapproved modification or improper maintenance of your engine. For engines less than 130 HP the warranty period is two years from the date of sale to the ultimate purchaser. For engines greater than or equal to 130 HP the warranty period is three year from the date of the engine being placed into service.

### Purchaser's/Owner's Warranty Responsibilities

As the engine purchaser/owner you are responsible for the following. 1.) The engine must be installed and configured in accordance to the installation specifications. 2.) The completion of all maintenance requirements listed in your Owner's Manual. 3.) Any engine setting adjustment must be done in accordance and consistent with the instructions in the Owner's Manual. 4.) Any emission control system or component must be maintained and operated appropriately in order to ensure proper operation of the engine and control system to minimize emissions at all times.

Generac may deny any, or all Emission Control System Warranty coverage or responsibility of the engine, or an emission control system or component on your engine thereof, if it has failed due to abuse, neglect, unapproved modification or improper maintenance, or the use of counterfeit and/or 'gray market' parts not made, supplied or approved by Generac. Warranty service/scheduled maintenance can be arranged by contacting your selling dealer or an Authorized Warranty Service dealer. The purchaser/owner shall be responsible for any expenses or other charges incurred for service calls and/or transportation of the product to/from the inspection or repair facilities. The purchaser/owner shall be responsible for any and/or all damages or losses incurred while the engine is being transported/shipped for inspection or warranty repairs.

### Emission Related Parts Include the Following (if so equipped)

- |   |  |
|---|--|
| 1) Fuel Metering System                                   | 3) Ignition System including                   |
| 1.1) Gasoline Carburetor assembly and internal components | a) Spark plug, b) Ignition module,             |
| a) Fuel filter, b) Carburetor, c) Fuel Pump               | c) ignition coil, d) Spark plug wirers         |
| 1.2) Carburetion assembly and its components              | 4) Exhaust system                              |
| a) Fuel controller, b) Carburetor and its gaskets,        | a) Catalyst assembly, b) Exhaust manifold,     |
| c) Mixer and it gaskets, d) Primary gas regulator         | c) Muffler, d) Exhaust pipe, e) Muffler gasket |
| e) Liquid vaporizer                                       | 5) Crankcase Breather Assembly including       |
| 1.3) Fuel Regulator                                       | a) Breather connection tube, b) PCV valve      |
| 2) Air Induction System including                         | 6) Oxygen Sensor                               |
| a) Intake pipe/manifold, b) Air cleaner                   | 7) Diagnostic Emission-Control System          |

### **United States Environmental Protection Agency Compliance Requirements**

#### **Purchaser's/Owner's Recordkeeping Responsibilities**

The United States Environmental Protection Agency (EPA) and Generac Power Systems, Inc. (Generac), are pleased to explain your recordkeeping requirements for compliance with Subpart JJJJ – Standards of Performance for Stationary Spark Ignition Internal Combustion Engines as listed in the Electronic Code of Federal Regulations Title 40 Part 60. As the engine purchaser/owner who operates and maintains their certified emergency stationary engine and emission control system according to applicable emission related guidelines as specified in this Owner's Manual you are required to meet the following notification and recordkeeping requirements to demonstrate compliance. 1.) Maintain documentation that the engine is certified to meet emission standards. 2.) Recordkeeping of maintenance conducted. 3.) Recordkeeping of the provision allowing natural gas engines to operate using propane for a maximum of 100 hours per year as an alternate fuel solely during emergency operations provided the engine is not certified to operate on propane. 4.) Meet all compliance notifications submitted to the purchaser/owner and maintain all supporting documentation. 5.) Recordkeeping of hours of operation, including what classified the operation as emergency and how many hours are spent for non-emergency operation. For emergency engines greater than or equal to 130 HP, recordkeeping of hours of operation begins January 1, 2011. For emergency engines less than 130 HP, recordkeeping of hours of operation begins January 1, 2009; Engines are equipped with non-resettable hour meters to facilitate recordkeeping.

Specific Air Quality Management or Air Pollution Control Districts may have different and additional record keeping/ reporting requirements. Your permit to construct and/or operate the engine may be contingent upon compliance with those requirements. Check with your local Air Quality Management or Air Pollution Control District for specific requirements.

Emergency stationary internal combustion engines (ICE) may be operated for the purpose of maintenance checks and readiness testing, provided that the tests are recommended by Federal, State or local government, Generac, or the insurance company associated with the engine. Maintenance checks and readiness testing of such units is limited to 100 hours per year. There is no time limit on the use of emergency stationary ICE in emergency situations. The purchaser/owner may petition the Administrator for approval of additional hours to be used for maintenance checks and readiness testing, but a petition is not required if the owner maintains records indicating that Federal, State, or local standards require maintenance and testing of emergency ICE beyond 100 hours per year. Emergency stationary ICE may operate up to 50 hours per year in non-emergency situations, but those 50 hours are counted towards the 100 hours per year provided for maintenance and testing. The 50 hours per year for non-emergency situations cannot be used for peak shaving or to generate income for a facility to supply power to an electric grid or otherwise supply power as part of a financial arrangement with another entity. For purchaser/owner of emergency engines, any operation other than emergency operation, maintenance and testing, and operation in non-emergency situations for 50 hours per year, as permitted in this section is prohibited.

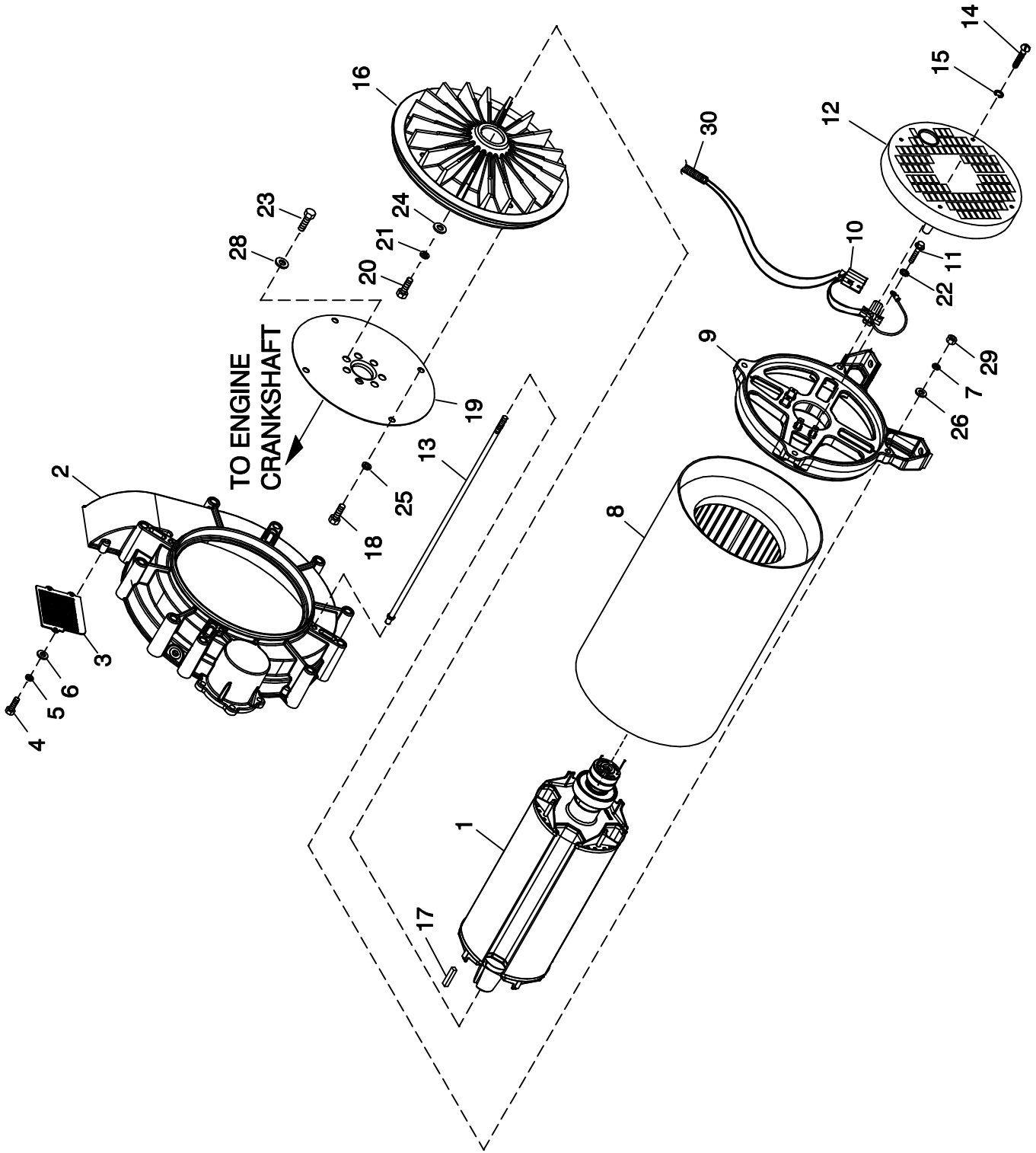
If you operate and maintain your certified emergency stationary SI internal combustion engine and emissions control systems in accordance with the specifications and guidelines in the Owner's Manual, EPA will not require engine performance testing. If not, your engine will be considered non-certified and you must demonstrate compliance according to Subpart JJJJ – Standards of Performance for Stationary Spark Ignition Internal Combustion Engines as listed in the Electronic Code of Federal Regulations Title 40 Part 60.

#### **Emission-Related Installation Instructions**

Your certified emergency stationary engine has pre-set emission control systems or components that require no adjustment. Inspection and replacement of an emissions related component is required to be done in accordance with the requirements cited in the United States Environmental Protection Agency Warranty Statement or can be arranged by contacting your selling dealer or an Authorized Warranty Service dealer. Failing to follow these instructions when installing a certified engine in a piece of nonroad equipment violates federal law 40 CFR 1068.105 (b), subject to fines or penalties as described in the Clean Air Act.



# GROUP A



EXPLODED VIEW:  
ALT COMMON PARTS 2.4L 10" ALT 22KW & 27KW  
DRAWING #: 0G8881

## EXPLODED VIEW: ALT COMMON PARTS 2.4L 10" ALT 22KW &amp; 27KW

DRAWING #: 0G8881

GROUP A

APPLICABLE TO:

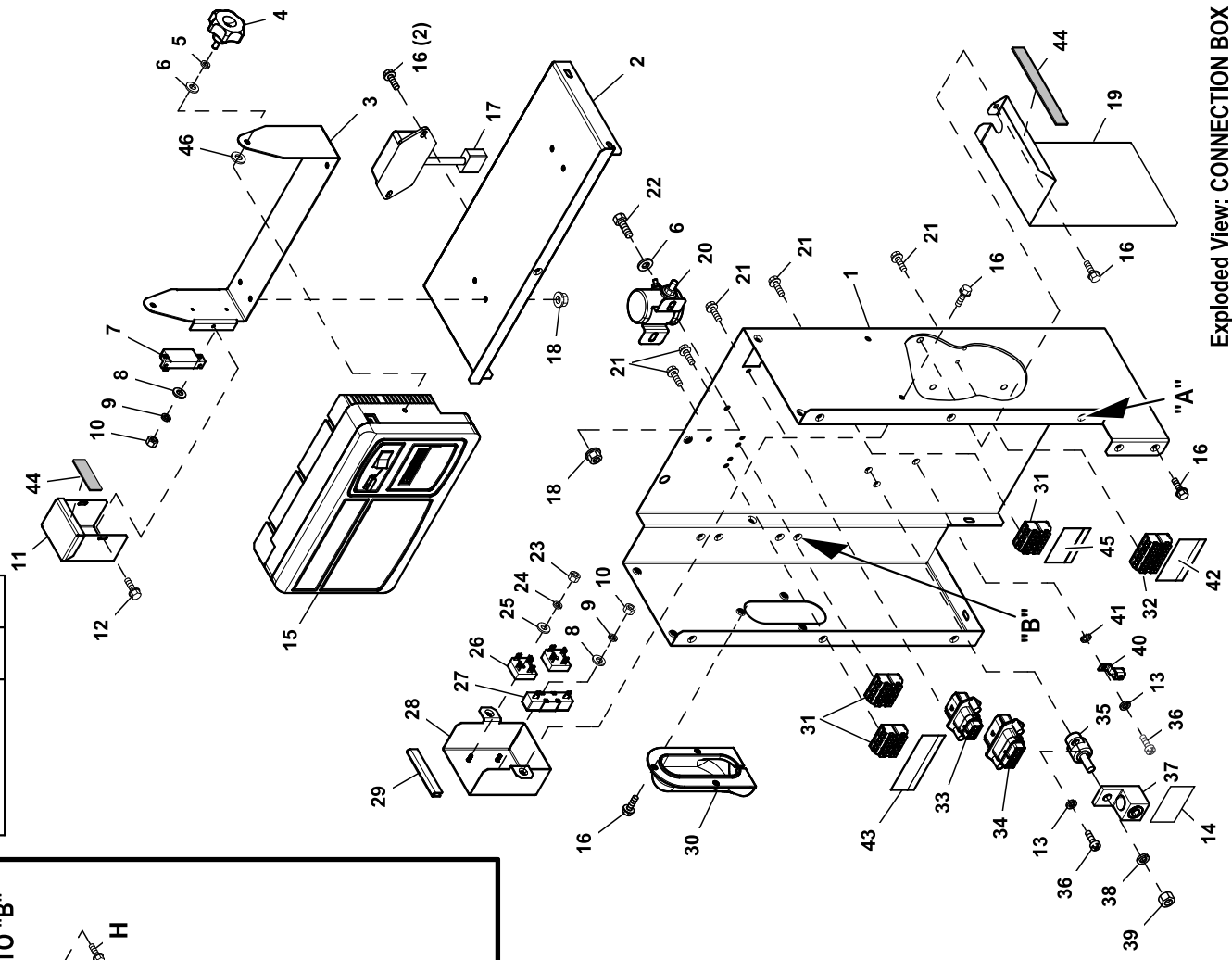
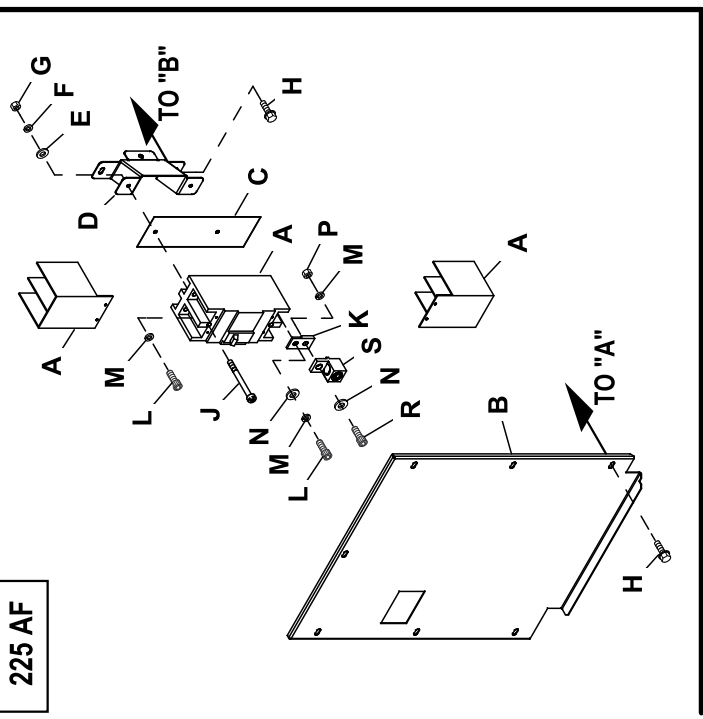
ITEM	PART #	QTY.	DESCRIPTION
1	0G9009	1	RTR-104-22AD1 HI EFF
	0G9011	1	RTR-104-27AD2 HI EFF
	0G9341	1	RTR-104-22GD1 HI EFF
	0G9342	1	RTR-104-27GD2 HI EFF
2	0G8318A	1	HOUSING BLOWER MACHINED 2.4L
3	0G8366	1	BLOWER HOUSING SCREEN
4	020746	3	SCREW PPHM M5-0.8 X 8 ZINC
5	049226	3	WASHER LOCK M5
6	051713	3	WASHER FLAT M5
7	022129	4	WASHER LOCK M8-5/16
8	0G9008	1	STR-104-22AD1 HI EFF
	0G9010	1	STR-104-27AD1 HI EFF
	0G9339	1	STR-104-22GD1 HI EFF
	0G9340	1	STR-104-27GD1 HI EFF
9	0A5382A	1	BEARING CARRIER REAR LG PILOT
10	075591	1	ASSY HOLDER BRUSH
11	051787	4	SCREW HHC M4-0.7 X 16 G8.8
12	0A5601A	1	COVER REAR BEARING
13	0G8827	4	STUD M8-1.25 475 LONG (27KW)
	0G8827A	4	STUD M8-1.25 418 LONG (22KW)
14	0A9375	4	SCREW RHM #10-24 X 2
15	022152	4	WASHER LOCK #10
16	0G8311	1	FLYWHEEL & RINGGEAR ASSY 2.4L
17	042558	1	KEY SQ 3/8 X 1 STEEL
(1) 18	051756	4	SCREW HHC M10-1.5 X 20 C8.8
19	0G8364	1	PLATE FLEX 2.4L 10" ALT
(1) 20	053607	1	SCREW HHC M12-1.75 X 35 G8.8
21	051769	1	WASHER LOCK M12
22	023365	4	WASHER SHAKEPROOF INT #8
(1) 23	0G0114	7	SCREW HHC M12-1.25 X 15 C10.9
24	072578	1	SPACER ROTOR SHAFT
25	0D8427	4	WASHER LOCK M10 RIBBED ZINC
26	0A8830	4	WASHER FLAT .34 ID X .75 OD
27	029333A	7	TIE WRAP UL 7.4"X .19" BLK (NOT SHOWN)
28	063076	7	WASHER FLAT .531ID X 1.062OD
29	045771	4	NUT HEX M8-1.25 G8 CLEAR ZINC
30	077043A	1	CONDUIT FLEX .38"ID ( 18" LG)
31	077043C	1	CONDUIT FLEX .75"ID ( 18" LG) (NOT SHOWN)

(1) APPLY MEDIUM STRENGTH BLUE THREADED LOCKING FLUID TO THREADS.

225 AF

GROUP A

CI LIFE BREAKER SELECTION	ITEM 7 PARTING	ITEM 7 P/N
22KX/22XN - 10	3A	054002
28KX/28XN - 10	4EA	040978
28KX/28XN - 30	5EA	054480
22KX/22XN - 50	6A	040805



Exploded View: CONNECTION BOX C1 CPL  
Drawing No.: 0H7234



**EXPLODED VIEW: CONNECTION BOX C1 CPL**

**DRAWING #: 0H7234**

**GROUP A**

**APPLICABLE TO:**

ITEM	PART#	QTY.	DESCRIPTION
1	0H6795	1	CONBOX BACK/SIDES C1 CPL
2	0H6796	1	CONBOX TOP C1 CPL
(4)3	0H67330STOR	1	BRACKET GIMBAL CONTROL PNL RAW
4	0H7115	2	KNOB M6-1.0 CONTROL PANEL
5	022097	2	WASHER LOCK M6-1/4
6	022473	4	WASHER FLAT 1/4-M6 ZINC
(3)7	SEE CHART	1	CIRCUIT BREAKER
8	052777	3	WASHER FLAT M3
9	043182	3	WASHER LOCK M3
10	051714	3	NUT HEX M3-0.5 G8 CLEAR ZINC
(4)11	0H81040ASOR	1	COVER DPE BREAKER NEXUS
12	045764	2	SCREW HHTT M4-0.7 X 8 ZP
13	022264	3	WASHER LOCK #8-M4
14	0A9457	1	DECAL NEUTRAL
15	0H7668A	1	ASSY CTRL 2010 CPL PROGRAMMED
16	0C2454	18	SCREW HWHT M6-1 X 16 N WA Z/JS
(2)17	0A1354A	1	REGULATOR - DC ALT
18	0D3700	6	NUT FLANGE M6-1.0 NYLON
(4)19	0H88380STOR	1	SHIELD HIGH/LOW C1 RAW
20	056739	1	RELAY SOLENOID 12VDC PNL MNT
21	0F5458	12	SCREW HHSP #10 X 3/8 HI-LOW
22	042568	2	SCREW HHC M6-1.0 X 20 C8.8
23	051716	2	NUT HEX M5-0.8 G8 CLEAR ZINC
24	049226	2	WASHER LOCK M5
25	051713	2	WASHER FLAT M5
26	0D7177V	2	DIODE BRIDGE 1P 35A 1000V
27	0F5752F	1	RES WW 15R 5% 25W QK CONN
28	0H6267	1	COVER VOLTAGE SHIELD
29	056326	1	TRIM VINYL BLACK 1/8GP (3"LG)
30	0G3524	1	COVER BELL HOUSING CONBOX
(1)31	0D7393T	REF	TERM BLOCK 3P UL 12-20AWG
(1)32	0D7393U	REF	TERM BLOCK 4P UL 12-20AWG
(1)33	0F5376S0AR	REF	MX150L SLRRMNT 22-18 8P W/O GA
(1)34	0F5396S0AR	REF	MX150L SLRRMNT 22-18 12P W/OGA
35	057073	1	JUNCTION BLOCK 3/8-16
36	0C2265	3	SCREW PHTT M4-0.7 X 12 ZP
37	057329	1	LUG SLDLSS 350-#6X13/32 AL/CU
38	022237	1	WASHER LOCK 3/8
39	022241	1	NUT HEX 3/8-16 STEEL
40	025433	1	LUG SLDLSS #6-14 X 13/64 CU
41	023762	1	WASHER LOCK EXT #10 STL
42	0H7292	1	DECAL CUSTOMER CONTROL CONNECT
43	0H7293	1	DECAL CONBOX TB1 CONNECTIONS
44	029289	1	TAPE ELEC 1/2 FOAM (9" LG)
45	0H7291	1	DECAL CUSTOMER POWER CONNECT
46	0A2115	2	WASHER NYLON .257
47	0F6146	1	HANG TAG 2 WIRE START (NOT SHOWN)
48	0H6692	1	HARN CONBOX NEXUS (NOT SHOWN)
			UL CIRCUIT BREAKER (225AF)
A	0G5249	1	CB 150A 2 POLE 240V 225AF
B	0H6846	1	COVER CB G 225AF C1 CONBOX
C	0F8432A	1	INSULATOR CB 2P 225AF
D	0G5734	1	SPRT CIRCUIT BREAKER G 225AF
E	038150	2	WASHER FLAT #8 ZINC
F	022264	2	WASHER LOCK #8-M4
G	022471	2	NUT HEX #8-32 STEEL
H	0C2454	10	SCREW HWHT M6-1 X 16 N WA Z/JS
J	053640	2	SCREW RHM #8-32 X 3-1/4
K	0F8843	2	BUS BAR 200A LUG ADAPTOR
L	049897	4	SCREW SHC M8-1.25 X 20 G8
M	022129	6	WASHER LOCK M8-5/16

**EXPLODED VIEW: CONNECTION BOX C1 CPL**

**DRAWING #: 0H7234**

**GROUP A**

**APPLICABLE TO:**

ITEM	PART#	QTY.	DESCRIPTION
N	022145	4	WASHER FLAT 5/16-M8 ZINC
P	045771	2	NUT HEX M8-1.25 G8 CLEAR ZINC
R	058306	2	SCREW SHC M8-1.25 X 25 C12.9
S	0F8451	2	LUG SLDLSS 300 MCM-6 AL/CU

(1) ITEMS INCLUDED WITH HARNESS P/N 0H6692.

(2) ITEMS USED ON 1.6L MODELS ONLY.

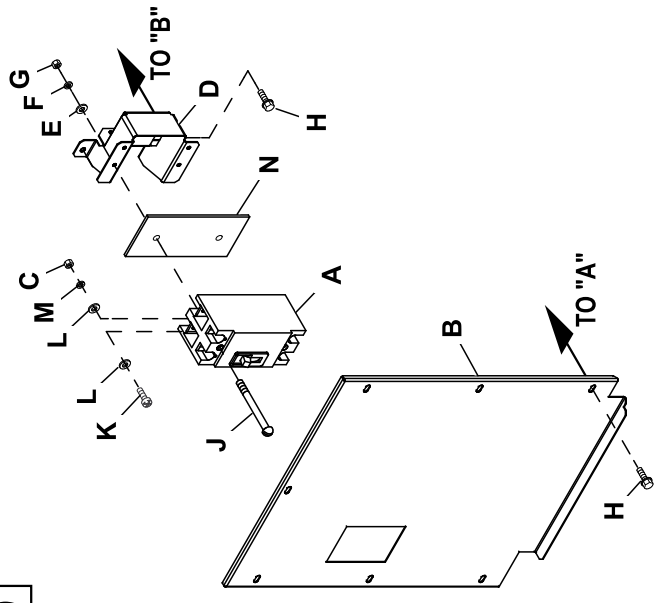
(3) SEE "C1 DPE BREAKER SELECTION" TABLE.

(4) SHEET METAL PARTS LISTED IN THE BOM TABLE ARE REPRESENTING GENERIC PARTS (NO COLOR).

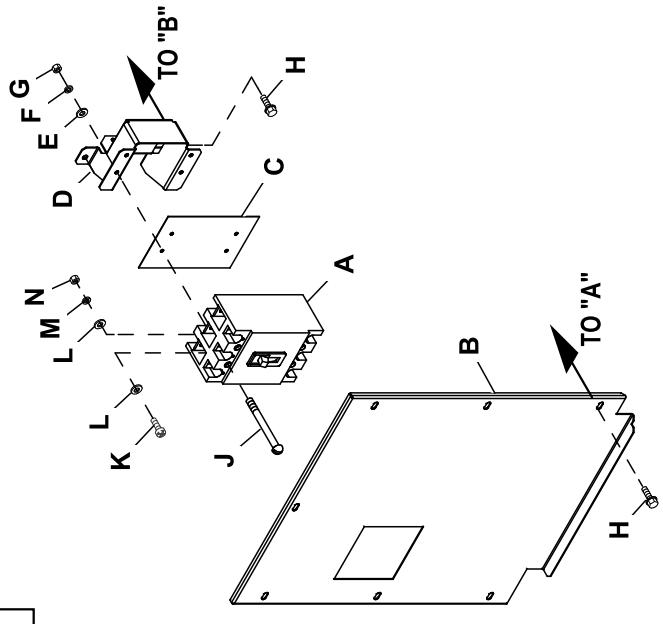
- **MANUFACTURING:** FOR CORRECT MATERIAL AND COLOR REFER TO AS400 BOM.
- **CUSTOMER:** FOR CORRECT MATERIAL AND COLOR OF REPLACEMENT PARTS REFER TO "REPLACEMENT SHEET METAL PARTS ORDERING GUIDE-0H7169" INCLUDED IN THE MANUAL OR AVAILABLE ON THE GENERAC WEBSITE.

# GROUP A

CC (2P)



CC (3P)

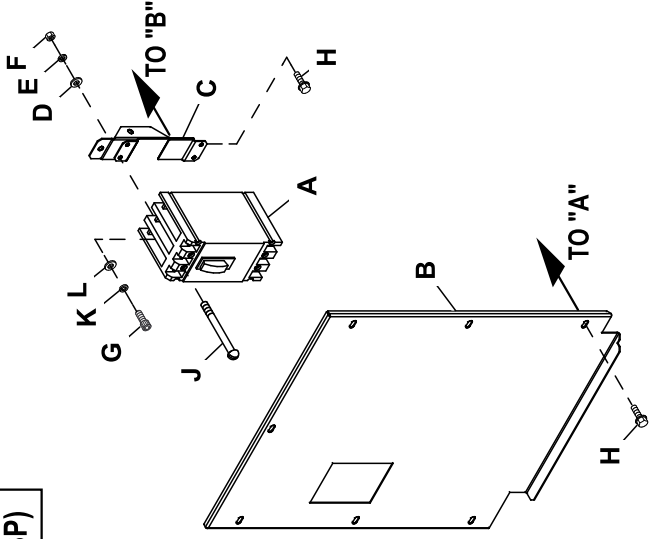


**EXPLODED VIEW: CONNECTION BOX C1 CPL****DRAWING #: 0H7234****GROUP A****APPLICABLE TO:**

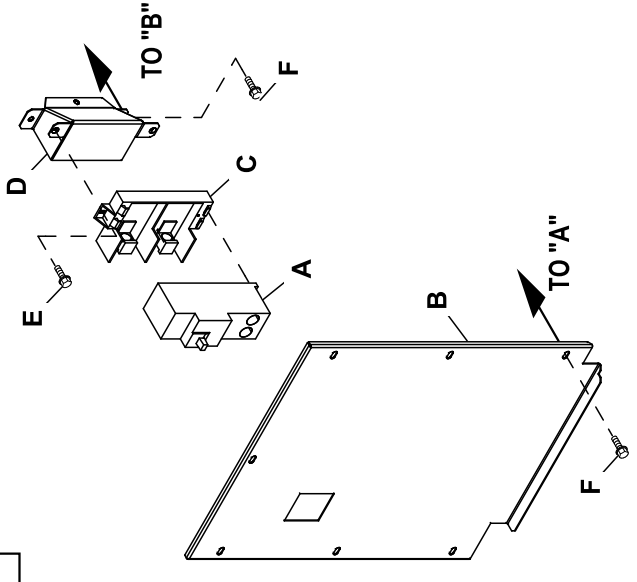
ITEM	PART#	QTY.	DESCRIPTION
			UL CIRCUIT BREAKER (CC 2P)
A	0H4745	1	CB 0100A 2P 240V E CC LL
B	0H6847	1	COVER CB E CC 2P C1 CONBOX
C	051716	2	NUT HEX M5-0.8 G8 CLEAR ZINC
D	0H4656	1	CIRCUIT BREAKER SUPPORT (CC)
E	038150	2	WASHER FLAT #8 ZINC
F	022264	2	WASHER LOCK #8-M4
G	022471	2	NUT HEX #8-32 STEEL
H	0C2454	10	SCREW HWHT M6-1 X 16 N WA Z/JS
J	053640	2	SCREW RHM #8-32 X 3-1/4
K	091526	2	SCREW PPHM M5-0.8 X 12 ZNC
L	023897	4	WASHER FLAT #10 ZINC
M	049226	2	WASHER LOCK M5
N	0H4698	1	INSULATOR CB 2P E TYPE CC
			UL CIRCUIT BREAKER (CC 3P)
A	0H4914	1	CB 0125 3P 240V E CC LL
B	0H7294	1	CB COVER E CC/FG 3P C1 CONBOX
C	0H4698A	1	INSULATOR CB 3P E TYPE CC/FG
D	0H4656	1	CIRCUIT BREAKER SUPPORT (CC)
E	038150	4	WASHER FLAT #8 ZINC
F	022264	4	WASHER LOCK #8-M4
G	022471	4	NUT HEX #8-32 STEEL
H	0C2454	10	SCREW HWHT M6-1 X 16 N WA Z/JS
J	053640	4	SCREW RHM #8-32 X 3-1/4
K	091526	3	SCREW PPHM M5-0.8 X 12 ZNC
L	023897	6	WASHER FLAT #10 ZINC
M	049226	3	WASHER LOCK M5
N	051716	3	NUT HEX M5-0.8 G8 CLEAR ZINC

# GROUP A

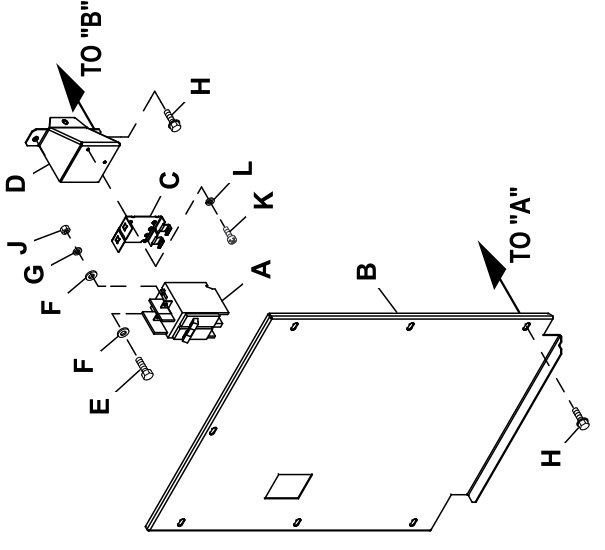
ED (3P)



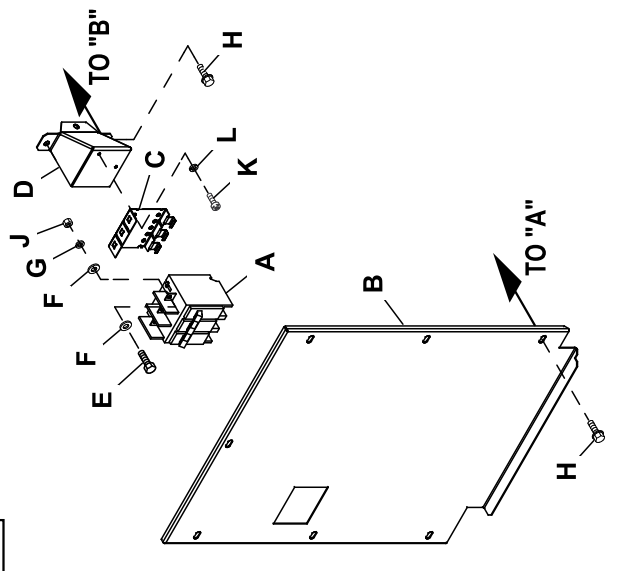
QN2



BQ (2P)



BQ (3P)



**EXPLODED VIEW: CONNECTION BOX C1 CPL**

**DRAWING #: 0H7234**

**GROUP A**

**APPLICABLE TO:**

ITEM	PART#	QTY.	DESCRIPTION
UL CIRCUIT BREAKER (BQ 2P)			
A	0A2077	1	CB 0125A 2P 240V S BQ2 LL
B	0H6842	1	COVER CB S BQ2 C1 CONBOX
C	0E7890	1	BRKT CB MTG BACK
D	0G4497	1	CIRCUIT BREAKER SUPPORT (BQ)
E	052619	2	SCREW HHC M5-0.8 X 20 G8.8
F	023897	4	WASHER FLAT #10 ZINC
G	049226	2	WASHER LOCK M5
H	0C2454	10	SCREW HWHT M6-1 X 16 N WA Z/JS
J	051716	2	NUT HEX M5-0.8 G8 CLEAR ZINC
K	0G9708	2	SCREW PHTT M4-0.7 X 8 ZP
L	022264	2	WASHER LOCK #8-M4
UL CIRCUIT BREAKER (BQ 3P)			
A	040532	1	CB 0100A 3P 240V S BQ3 LL
B	0H6843	1	COVER CB S BQ3 C1 CONBOX
C	0E6002	1	MTG TRACK BQ SIEMENS CB 3P
D	0G4497	1	CIRCUIT BREAKER SUPPORT (BQ)
E	052619	3	SCREW HHC M5-0.8 X 20 G8.8
F	023897	6	WASHER FLAT #10 ZINC
G	049226	3	WASHER LOCK M5
H	0C2454	10	SCREW HWHT M6-1 X 16 N WA Z/JS
J	051716	3	NUT HEX M5-0.8 G8 CLEAR ZINC
K	0G9708	2	SCREW PHTT M4-0.7 X 8 ZP
L	022264	2	WASHER LOCK #8-M4
UL CIRCUIT BREAKER (ED 3P)			
A	0D9693	1	CB 0125A 3P 480V S ED4 LL
B	0H6844	1	COVER CB S ED3 C1 CONBOX
C	0G4498	1	CIRCUIT BREAKER SUPPORT (ED)
D	038150	4	WASHER FLAT #8 ZINC
E	022264	4	WASHER LOCK #8-M4
F	022471	4	NUT HEX #8-32 STEEL
G	0A8278	3	SCREW SHC 1/4-28 X 3/4 G8.8 NZ
H	0C2454	10	SCREW HWHT M6-1 X 16 N WA Z/JS
J	066715	4	SCREW RHM #8-32 X 4-1/2
K	022097	3	WASHER LOCK M6-1/4
L	0D5621	3	WASHER-STEP 1/2ODX9/32ID BRASS
UL CIRCUIT BREAKER (QN2 2P)			
A	0E7283	1	CB 0150A 2P 240V S QN2 LL
B	0H6845	1	COVER CB S QN2 C1 CONBOX
C	0E3664	1	BASE, QN CIRCUIT BREAKER
D	0G4112	1	BREAKER SUPPORT BRACKET 30KW
E	074908	2	SCREW HHTT M5-0.8 X 10 BP
F	0C2454	10	SCREW HWHT M6-1 X 16 N WA Z/JS

**EXPLODED VIEW: CONNECTION BOX C1 CPL**

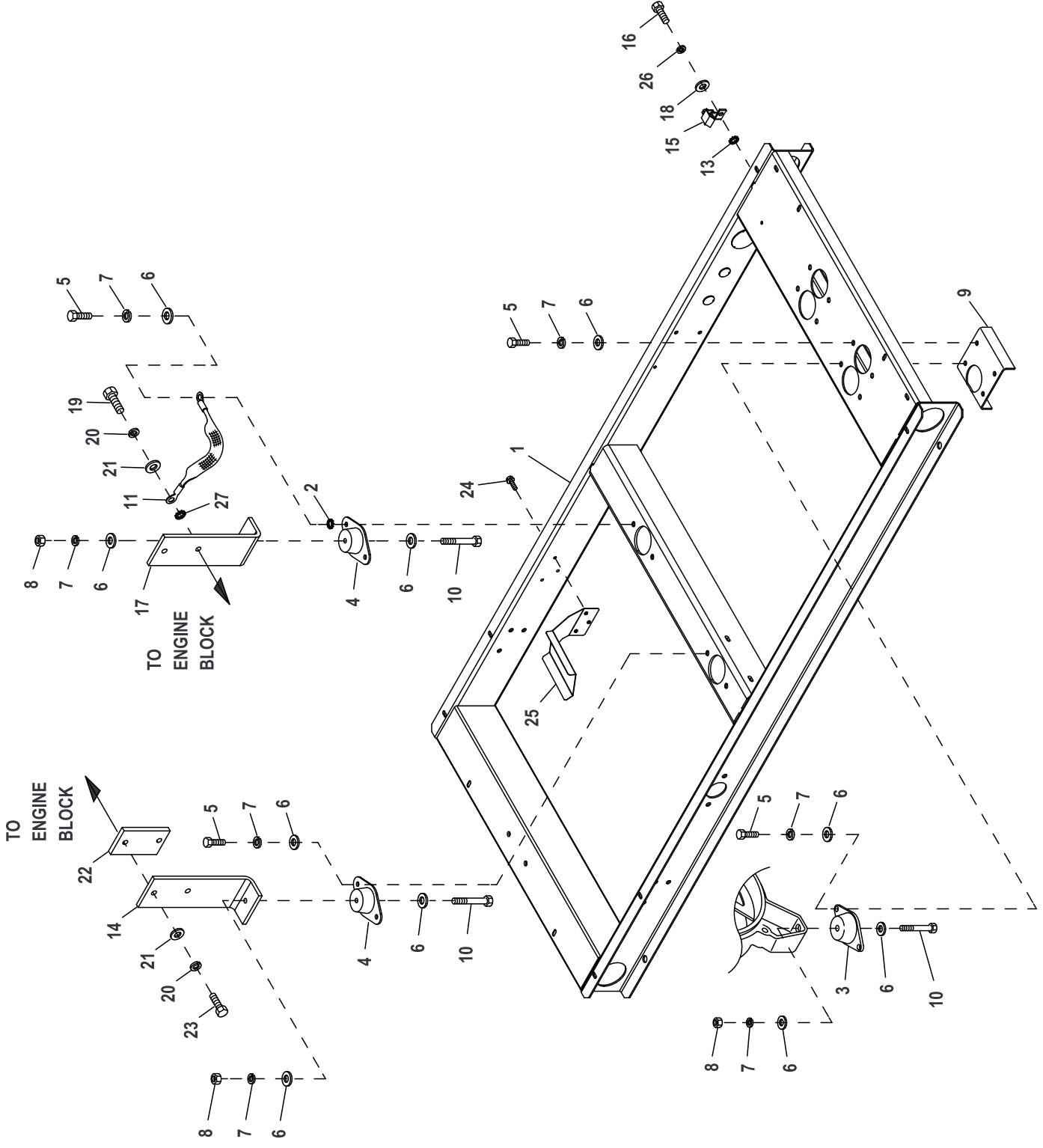
**DRAWING #: 0H7234**

**APPLICABLE TO:**

**GROUP A**

**THIS PAGE LEFT INTENTIONALLY BLANK**

# GROUP C

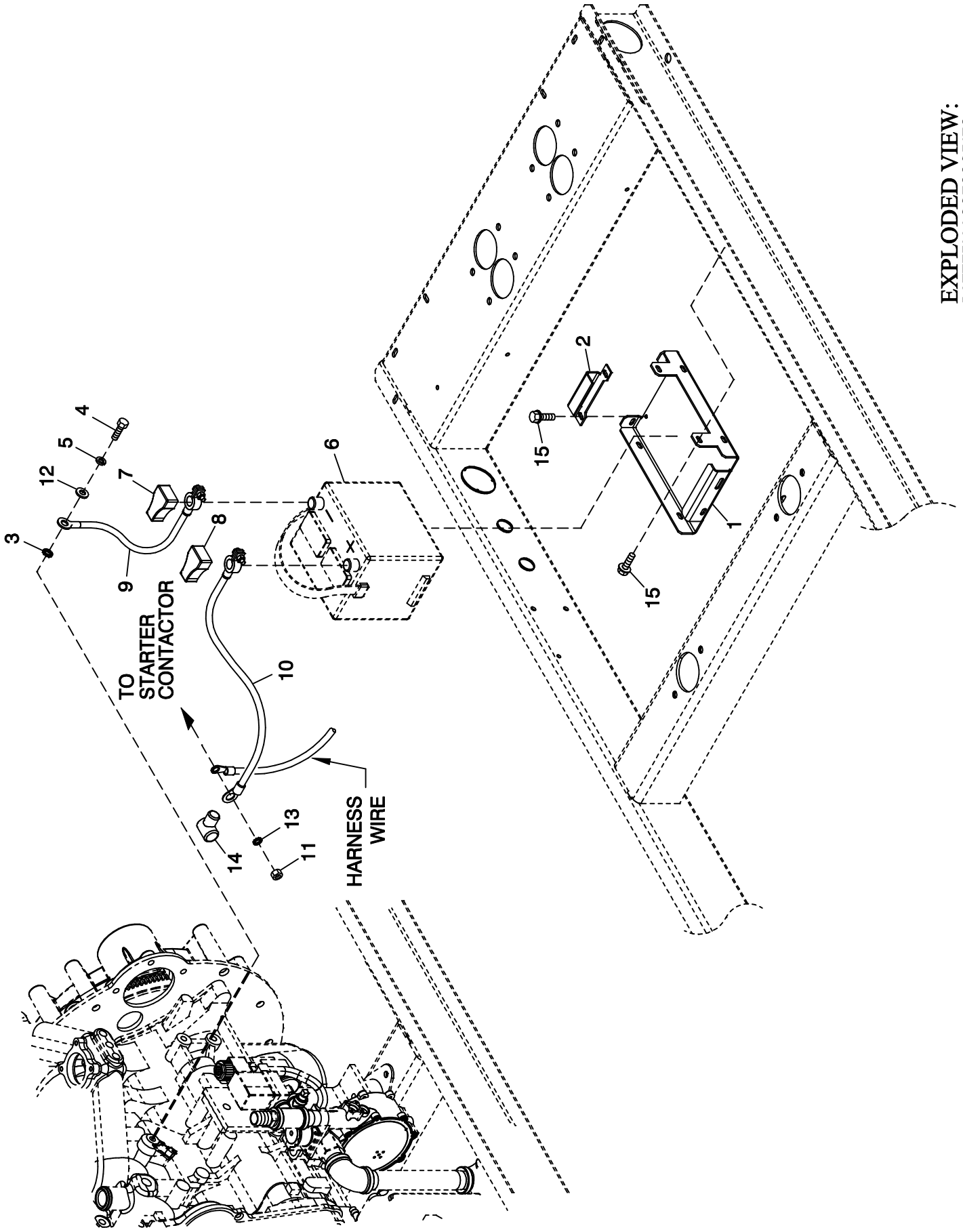




**EXPLODED VIEW: MOUNTING BASE 2.4L****DRAWING #: 0G8784****GROUP C****APPLICABLE TO:**

ITEM	PART#	QTY.	DESCRIPTION
1	0G83760ST03	1	MOUNTING BASE 2.4L
2	027482	2	WASHER SHAKEPROOF EXT 5/16 STL
3	070936	2	DAMPENER VIBRATION
4	070936C	2	VIB. ISO. 70-75 DURO
5	039253	12	SCREW HHC M8-1.25 X 20 G8.8
6	022145	20	WASHER FLAT 5/16 ZINC
7	022129	16	WASHER LOCK M8-5/16
8	045771	4	NUT HEX M8-1.25 G8 YEL CHR
9	0G3461	2	ALTERNATOR SUPPORT BLOCK OFF
10	051730	4	SCREW HHC M8-1.25 X 60 G8.8
11	021991	1	EARTH STRAP
13	026850	1	WASHER SHAKEPROOF EXT 1/4 STL
14	0G8429AST03	1	SUPPORT ENGINE LEFT SIDE
15	055414	1	LUG SLDLSS #2-#8 X 17/64 CU
16	047411	1	SCREW HHC M6-1.0 X 16 G8.8
17	0G84290ST03	1	SUPPORT ENGINE RIGHT SIDE
18	022473	5	WASHER FLAT 1/4-M6 ZINC
19	062963	2	SCREW HHC M10-1.25 X 30 C8.8
20	046526	4	WASHER LOCK M10
21	022131	4	WASHER FLAT 3/8-M10 ZINC
22	0F9596A	1	SPACER LH ENGINE MOUNT
23	052211	2	SCREW HHC M10-1.25 X 40 C8.8
24	0C2454	3	SCREW HWHT M6-1 X 16 N WA Z/JS
25	0H6121	1	HEAT SHIELD 2.4L G2
26	022097	1	WASHER LOCK M6-1/4
27	025507	1	WASHER LOCK EXT 7/16 STL

GROUP C



EXPLODED VIEW:  
BATTERY ACCESSORIES  
DRAWING #: 0G8894

EXPLODED VIEW: BATTERY ACCESSORIES

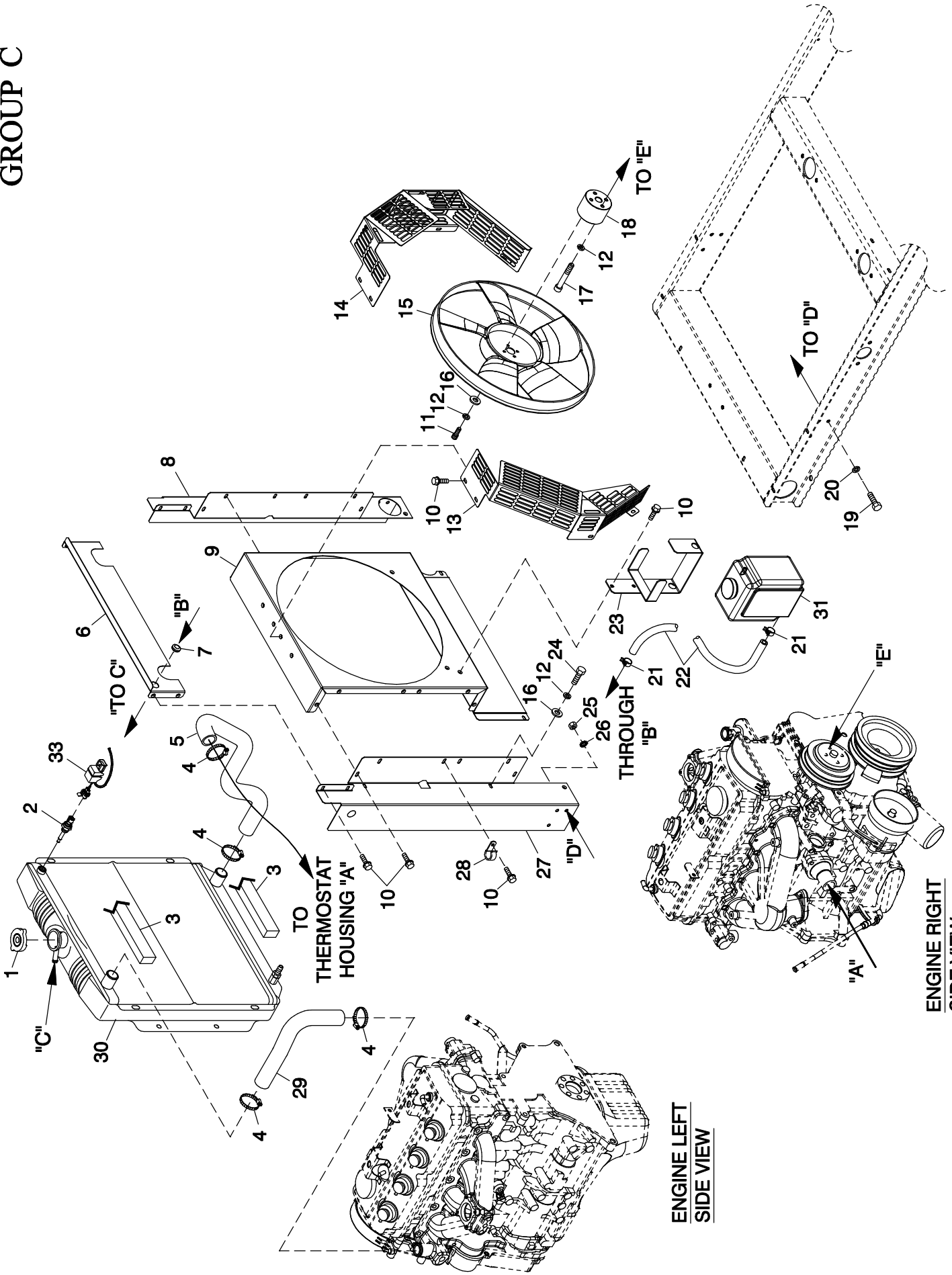
DRAWING #: 0G8894

GROUP C

APPLICABLE TO:

ITEM	PART #	QTY.	DESCRIPTION
1	0F3408C	1	BATTERY TRAY, C1 & C2
2	0F3411	1	STRAP BATTERY RETAINMENT
3	025507	1	WASHER SHAKEPROOF EXT 7/16 STL
4	052212	1	SCREW HHC M10-1.25 X 25 C8.8
5	046526	1	WASHER LOCK M10
6	077483	REF	BATTERY 12VDC 75-AH 26 (SOLD AS AN OPTION)
7	050331A	REF	BATTERY POST COVER RED +
8	050331	REF	BATTERY POST COVER BLK -
9	038805J	1	CABLE BATTERY BLACK #1 X 30.00
10	038804M	1	CABLE BATTERY RED #1 X 21.00
11	045771	REF	NUT HEX M8-1.25 G8 YEL CHR
12	022131	1	WASHER FLAT 3/8-M10 ZINC
13	027482	1	WASHER SHAKEPROOF EXT 5/16 STL
14	0F3976	1	BOOT CONTACTOR CABLES
15	0C2454	6	SCREW THF M6-1 X 16 N WA Z/JS

# GROUP C



EXPLODED VIEW:  
COOLING SYSTEM 2.4L C1  
DRAWING #: 0G8886

## EXPLODED VIEW: COOLING SYSTEM 2.4L C1

DRAWING #: 0G8886

GROUP C

APPLICABLE TO:

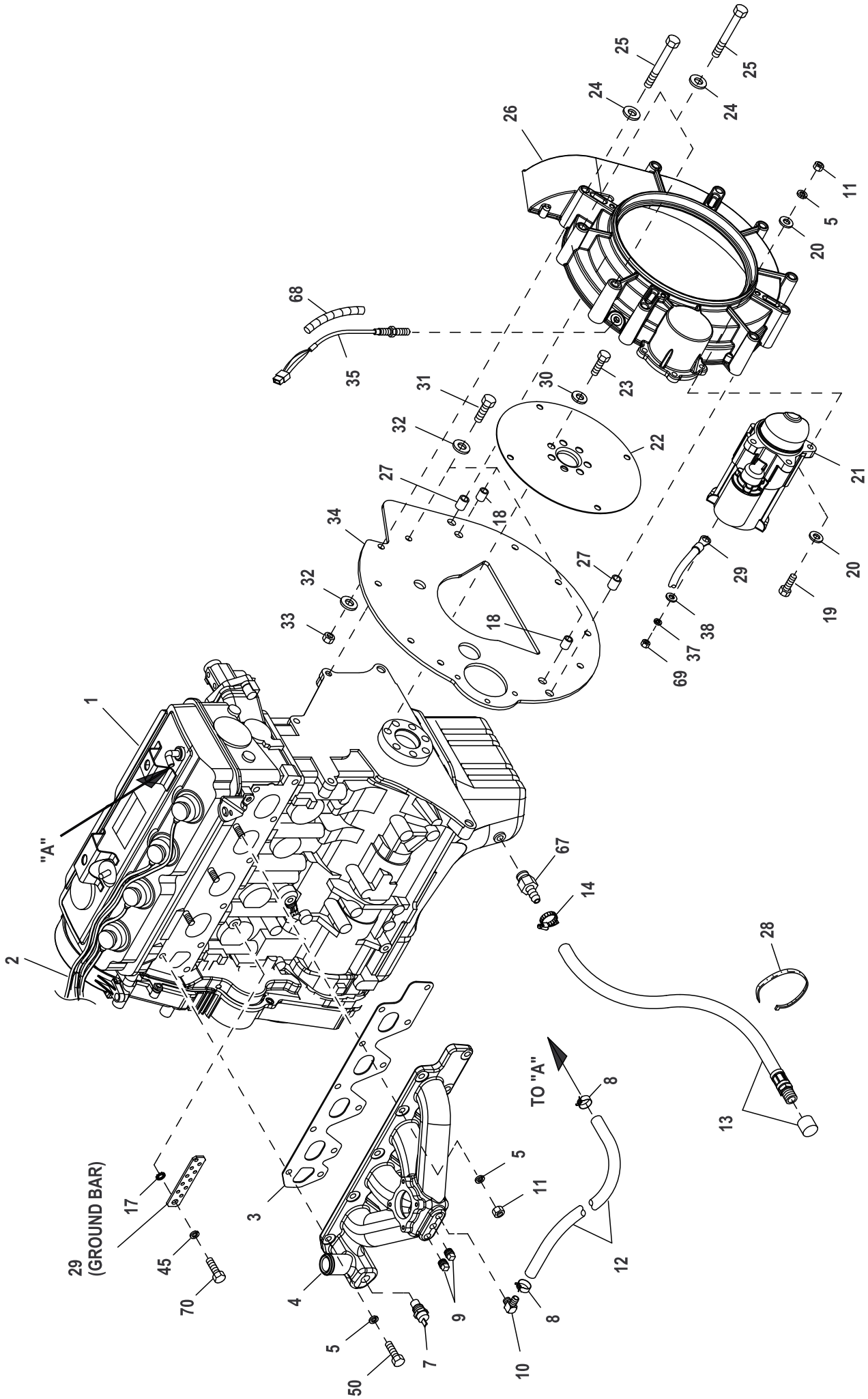
ITEM	PART #	QTY.	DESCRIPTION
1	046627	1	CAP RADIATOR 14PSI
2	0E2507	1	PROBE COOLANT LEVEL 3/8NPTF
	0H1827	1	PROBE COOLANT LEVEL 3/8-18NPTF (USE WITH I/N 33, P/N 0H1851)
3	052250	2	TAPE FOAM 1 X 1 (21" LG)
4	099502	4	CLAMP HOSE #24 B1.06-2.00
5	0G8831	1	HOSE LOWER RADIATOR 2.4L
6	0G81290GS0R	1	BLOCK OFF RADIATOR 2.4L
7	0F9504	1	GROMMET 5/8"X 1 1/8"X 5/16"
8	0G81280GS0R	1	SUPPORT RADIATOR RH SIDE 2.4L
9	0G81260GS0R	1	VENTURI 2.4L
10	0C2454A	25	SCREW THF M6-1 X 12 N WA Z/JS
11	042568	4	SCREW HHC M6-1.0 X 20 G8.8
12	022097	12	WASHER LOCK M6-1/4
13	0G89420GS0R	1	GUARD FAN LH
14	0G89430GS0R	1	GUARD FAN RH
15	0G8803	1	FAN COOL 460MM DIA 5 BLADE
16	022473	8	WASHER FLAT 1/4-M6 ZINC
(1) 17	082460	4	SCREW SHC M6-1.0 X 65 C12.9
18	0G8993	1	ADAPTER FAN 2.4L
(1) 19	039253	6	SCREW HHC M8-1.25 X 20 G8.8
20	022129	6	WASHER LOCK M8-5/16
(2) 21	048031C	2 (REF)	CLAMP HOSE BAND 1/4
22	029032	1	HOSE 9/32 ID (47" LG)
23	080713	1	BRACKET COOLANT TANK
24	0C8566	4	SCREW HHFC M6-1.0 X 20 G8.8
25	045771	6	NUT HEX M8-1.25 G8 CLEAR ZINC
26	027482	6	WASHER SHAKEPROOF EXT 5/16 STL
27	0G81270GS0R	1	SUPPORT RADIATOR LH SIDE 2.4L
28	082121A	1	CLIP-J VINYL COAT .375 ID
29	0G8830	1	HOSE UPPER RADIATOR 2.4L
30	0E9837C	1	RADIATOR
31	076749	1	TANK COOLANT RECOVERY
32	029333A	9	TIE WRAP UL 7.4" X .19" BLK (NOT SHOWN)
(3) 33	0H1851	1	ASSY PCB LCL SENSOR (USE WITH I/N 2, P/N 0H1827 ONLY)

(1) APPLY MEDIUM STRENGTH BLUE THREAD LOCKING FLUID TO THREADS.

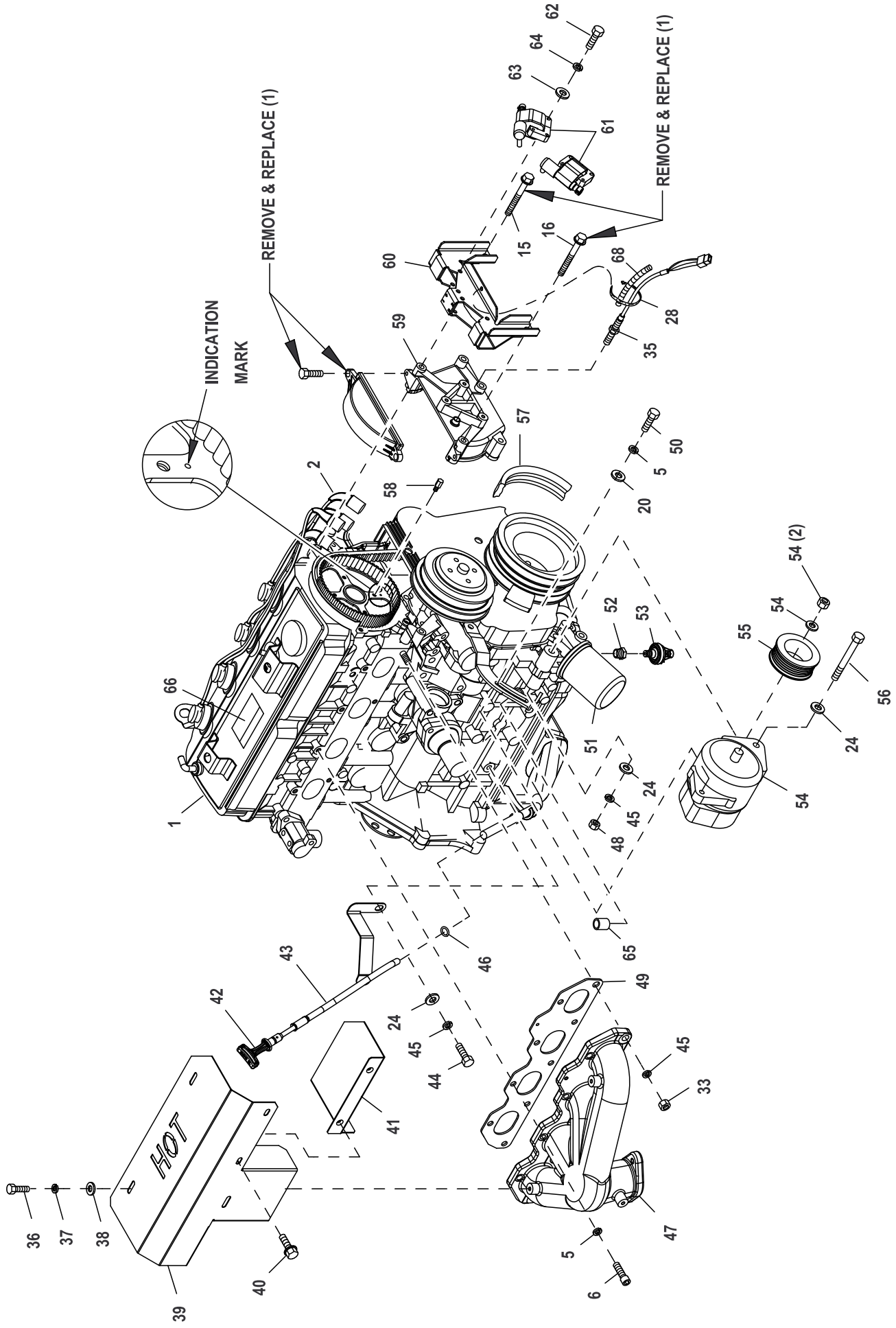
(2) INCLUDED WITH I/N 25.

(3) USE WITH R-200 CONTROL PANEL ONLY.

# GROUP D



# GROUP D



## EXPLODED VIEW: ENGINE COMMON PARTS 2.4L G2

DRAWING #: 0H7325

GROUP D

APPLICABLE TO:

ITEM	PART#	QTY.	DESCRIPTION
1	0H1619	1	ENGINE 2.4L G2
2	0G8854	1	SPARK PLUG WIRE SET 2.4L G2 IG
(1) 3	0G0950	1(REF)	GASKET INTAKE MANIFOLD G2
4	0G8488	1	MANIFOLD INTAKE (MACHINED)
5	022129	22	WASHER LOCK M8-5/16
6	058306	7	SCREW SHC M8-1.25 X 25 C12.9
7	0A6751	1	SWITCH HI-TEMP 245D X 3/8 NPT
	0E0502	1	TEMPERATURE SENDER, DELPHI
8	048031J	2	CLAMP HOSE BAND .63
9	026073A	2	PLUG STD PIPE 1/4 STEEL SQ HD
10	049340	1	BARBED EL 90 1/4 NPT X 3/8
11	045771	6	NUT HEX M8-1.25 G8 CLEAR ZINC
12	047290	1	HOSE 3/8 ID SINGLE BRAID (15" LG)
13	069860B	1	HOSE OIL DRAIN ASSY 16"
14	0C7649	1	CLAMP HOSE .38-.87
(1) 15	052203	1(REF)	SCREW HHC M8-1.25 X 70 C8.8
(1) 16	052265	1(REF)	SCREW HHC M8-1.25 X 65 C8.8
17	025507	1	WASHER SHAKEPROOF EXT 7/16 STL
18	0G8759A	2	BUSHING GUIDE 11.3MM LONG
19	039287	3	SCREW HHC M8-1.25 X 45 C8.8
20	022145	7	WASHER FLAT 5/16-M8 ZINC
21	0G7461	1	MOTOR STARTER
22	0G8364	1(REF)	PLATE FLEX 2.4L 10" ALT
(2) 23	0G0114	7(REF)	SCREW HHC M12-1.25 X 15 C10.9
24	022131	13	WASHER FLAT 3/8-M10 ZINC
25	0G9255	10	SCREW HHC M10-1.25 X 100 PC8.8
26	0G8318A	1(REF)	HOUSING BLOWER MACHINED 2.4L
27	0G8759	2	BUSHING GUIDE 19.3MM LONG
28	029333A	3	TIE WRAP UL 7.4"X .19" BLK
29	0H6689	1	HARN ENG G2.4L G2 NEXUS (NOT SHOWN)
30	063076	7(REF)	WASHER FLAT .531 ID X 1.062 OD
31	052830	3	SCREW HHC M10-1.25 X 45 C8.8
32	0D8427	11	WASHER LOCK M10 RIBBED ZINC
33	046525	10	NUT HEX M10-1.25 G8 YEL CHR
34	0G8365	1	ADAPTER ENGINE PLATE 2.4L G2
(2) 35	0D2244M	2	ASSY MAGPICKUP (3/8-24 MALE)
36	043116	3	SCREW HHC M6-1.0 X 12 G8.8
37	022097	4	WASHER LOCK M6-1/4
38	022473	4	WASHER FLAT 1/4-M6 ZINC
39	0G92210AS0R	1	SHIELD EXHAUST
40	0D6029	3	SCREW HHTT M6-1.0 X 16 ZYC
41	0G0792A	1	SHIELD HEAT SML
42	0F2664H	1	ASSY DIPSTICK W/TEXT GTH-530
43	0G8427A	1	ASSY DIPSTICK TUBE 2.4 G2
44	052213	1	SCREW HHC M10-1.25 X 20 C8.8
45	046526	5	WASHER LOCK M10
46	0G3823	1	O-RING SIZE 9.0MM X 2.0MM NITR
47	0G3910	1	EXHAUST MANIFOLD G2 (MACHINE)
48	045772	1	NUT HEX M10-1.5 G8 YEL CHR
(1) 49	0G0951	1(REF)	GASKET EXHAUST MANIFOLD
50	0A8258	9	SCREW HHC M8-1.25 X 25 C10.9
(1) 51	0A45310244	1(REF)	FILTER 1.5L/2.4L G2 OIL
52	042574	1	ADAPTOR 1/8 NPTF TO 1/8 BSPT
53	0A8584	1	SWITCH OIL PRESSURE 10 PSI 2 POL
(2) 54	0E9868A	1	ALTERNATOR DC W/OUT PULLEY
55	0G2750	1	PULLEY 69 OD DC ALTERNATOR
56	0E4507	1	SCREW HHC M10-1.5 X 120 C8.8
57	0D3488S	1	BELT SERPENTINE 37.0"
58	0G1472A	1	CAM SENSOR PIN ASSY
59	0G1477	1(REF)	COVER CAM GEAR G2 REWORKED
60	0G8852	1	BRACKET ASM-2.4L COIL G2
61	0G8853	4	COIL-2.4L G2 IGNITION
62	034413	8	SCREW HHM #10-32 X 1-1/4
63	023897	8	WASHER FLAT #10 ZINC



**EXPLODED VIEW: ENGINE COMMON PARTS 2.4L G2**

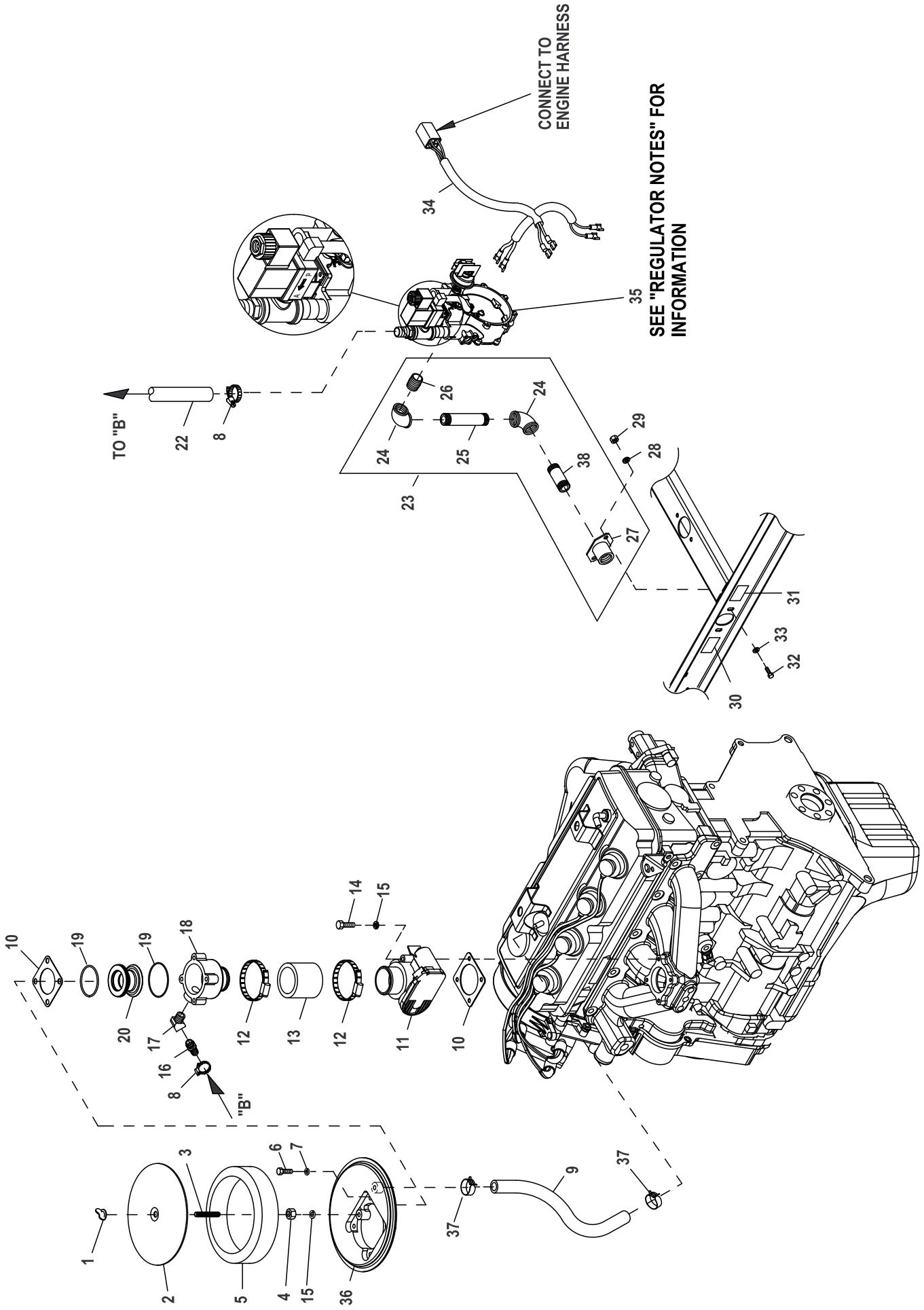
**DRAWING #: 0H7325**

**GROUP D**

**APPLICABLE TO:**

ITEM	PART#	QTY.	DESCRIPTION
64	022152	8	WASHER LOCK #10
(1) 65	0G9520	1 (REF)	PLUG TAPER
66	0G7313	1 (REF)	DECAL EMISSION CTRL INFO 2.4L
67	0C1852	1	ADAPTER DRAIN OIL
68	077043H	2	CONDUIT FLEX .25"ID (6"LG)
69	049813	1	NUT HEX M6 X 1.0 G8 YEL CHR
70	052213	1	SCREW HHC M10-1.25 X 20 C8.8

# GROUP E



**EXPLODED VIEW: FUEL SYSTEM 2.4L G2 22&27KW****DRAWING #: 0H7578****GROUP E****APPLICABLE TO:**

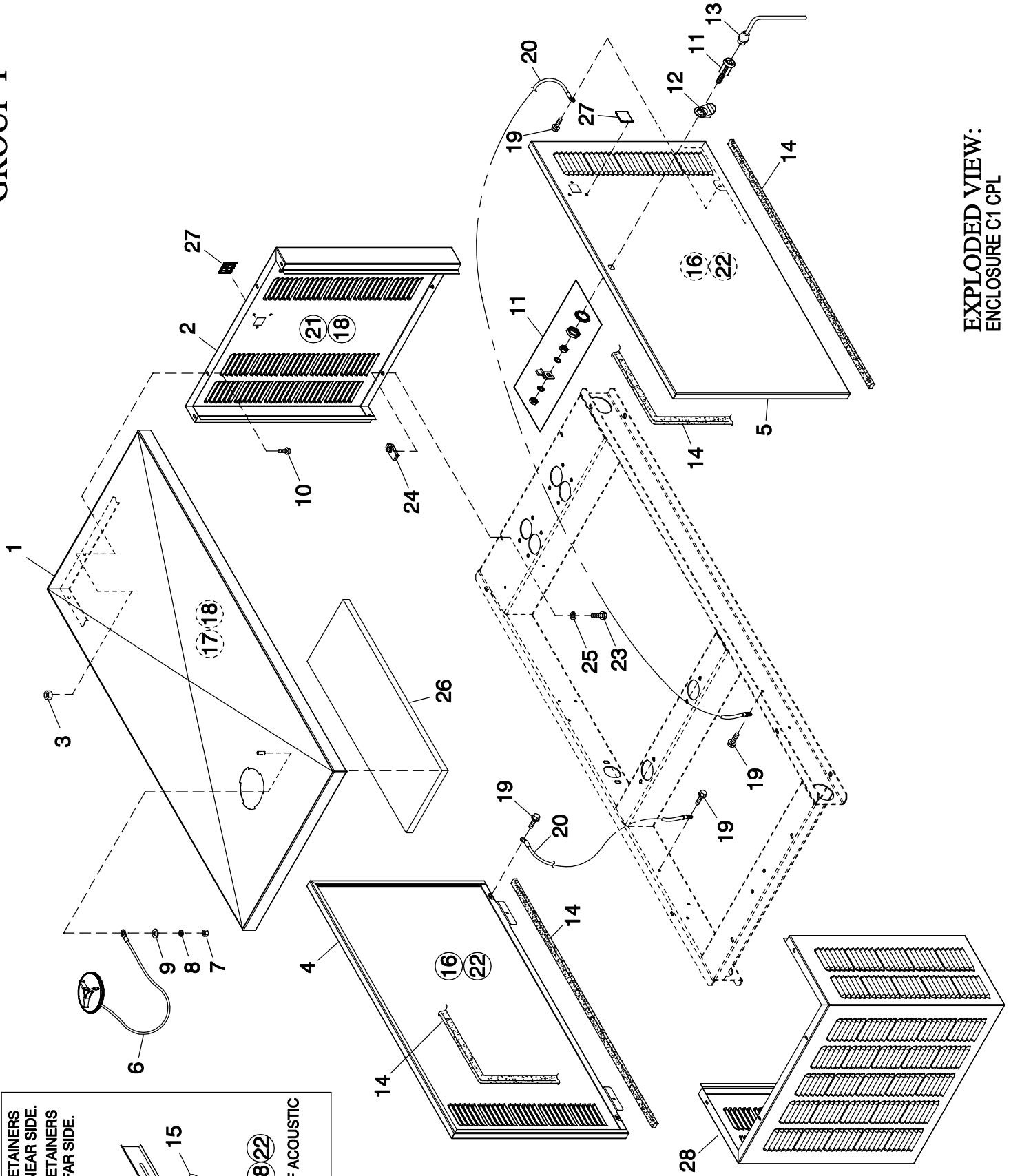
ITEM	PART#	QTY.	DESCRIPTION
1	037561	1	NUT WING 1/4-20 NYLK
2	0A5547	1	COVER AIR CLEANER
3	062522	1	STUD TH 1/4-20 X 3 G2 ZNC FULL
4	022127	1	NUT HEX 1/4-20 STEEL
5	059402	1	FILTER ELEMENT
6	091526	4	SCREW PPHM M5-0.8 X 12 ZNC
7	049226	4	WASHER LOCK M5
8	057823	2	CLAMP HOSE #10 .56-1.06
9	047290	1	HOSE 3/8 ID SINGLE BRAID (15" LG)
10	0E6586	2	GASKET BOSCH 32
11	0E4395	1	ACTUATOR BOSCH 32 GOVERNOR
12	035685	2	CLAMP HOSE #28 1.32-2.25
13	057753B	1	HOSE 1.5 ID X 2 LG 20R4
14	051767	4	SCREW HHC M6-1.0 X 45 C8.8 FTH
15	022097	5	WASHER LOCK M6-1/4
16	047527	1	BARBED STR 1/2 NPT X 3/4
17	0E8286	1	STREET EL 45D 1/2 NPT BRASS
18	0G4573C	1	MIXER ACTUATOR 32MM MACHINED
19	0E7121	2	O-RING 47.625 ID X 2.38 WIDTH
20	0F7790H	1	VENTURI THROTTLE 19MM
22	059057	1	HOSE 3/4 ID SAE-30R2 (18" LG)
23	0G9348	1	ASSY REG INLET NPT FITTINGS
(1) 24	026812	2	ELBOW 90D 3/4 NPT
(1) 25	076691	1	NIPPLE PIPE 3/4NPTX4.5 BLK IRN
(1) 26	026915	1	NIPPLE CLOSE 3/4 X 1.375
(1) 27	075580	1	FLANGE FUEL INLET
28	022129	2	WASHER LOCK M8-5/16
29	045771	2	NUT HEX M8-1.25 G8 YEL CHR
30	0D1509	1	DECAL INLET PRESSURE
31	075436	1	DECAL - FUEL INLET
32	039253	2	SCREW HHC M8-1.25 X 20 G8.8
33	022145	2	WASHER FLAT 5/16 ZINC
34	0H7436	1	HARN FUEL JUMPER SINGLE REG
35	0G1397C	1	FUEL REG REWORK 2.4 1800 22/27
36	0E0519A	1	ADAPTER, CARBURETOR W/PVC CONN
37	048031J	2	CLAMP HOSE BAND .63
(1) 38	026490	1	NIPPLE PIPE 3/4NPT X 2

(1) INCLUDED IN I/N 23 (ASSY REG INLET NPT FITTINGS )

**REGULATOR NOTES:**

REGULATOR (I/N 11) AS SHOWN IN ILLUSTRATION IS SET UP FOR NATURAL GAS APPLICATION.  
 TO CONFIGURE REGULATOR FOR LP VAPOR, REFER TO THE "RECONFIGURING THE FUEL SYSTEM" SECTION OF THIS MANUAL.

# GROUP F



○ INSULATION AND RETAINERS LOCATED ON THE NEAR SIDE.  
 ○ INSULATION AND RETAINERS LOCATED ON THE FAR SIDE.

RETAINER 18 22

TYPICAL MOUNTING OF ACOUSTIC INSULATION.

EXPLODED VIEW:  
ENCLOSURE C1 CPL  
DRAWING #: 0G3534

APPLICABLE TO:

ITEM	PART #	QTY.	DESCRIPTION
(2) 1	0G33370ST0R	1	ROOF 1.6L C1
(2) 2	0G33360ST0R	1	REAR INTAKE WRAP 1.6L C1
(1) 3	077992	10	NUT HEX LOCK M6-1.0 SS NY INS
(2) 4	0G33410ST0R	1	DOOR LEFT/RIGHT SIDE 1.6L C1
(2) 5	0G3341AST0R	1	DOOR LEFT/RIGHT SIDE 1.6L C1
6	0F4487A	1	ASSY ACCESS COVER
7	022127	1	NUT HEX 1/4-20 STEEL
8	022097	1	WASHER LOCK M6-1/4
9	022473	1	WASHER FLAT 1/4-M6 ZINC
10	0C2454	10	SCREW THF M6-1 X 16 N WA Z/JS
11	0F5048D	2	WISE-ACTION LATCH, SLOTTED CIR
12	0F5049	2	TAB PULL
13	0F8869D	1	KEY VISE-ACTION LATCH,SLOT CIR
14	089961	1	FOAM STRIP 3/4"WIDE X 3/16"THK (294"LG)
15	078115	18	WASHER SELF LOCKING DOME
16	0H7518	2	INSULATION SIDE DOOR C1
17	0H7518A	1	INSULATION ROOF C1
18	0F3890	5	RETAINER INSULATION (450)
19	0E3257	4	SCREW HWHTF M6-1.0 X 16
20	0912970090	2	ASSY WIRE 14AWG GRN/YEL (32.25"LG)
21	0H7518B	1	INSULATION REAR C1
22	0F3890B	4	RETAINER INSULATION (820)
23	0C8566	10	SCREW HHFC M6-1.0 X 20 G8.8
24	0H0412	10	NUT SPRINGCLIP M6-1.0
25	022097	10	WASHER LOCK M6-1/4
(3) 26	0H7529	1	FOIL ALUMINUM WITH ADHESIVE
27	0H1208A	2	RF COVER PLATE-PLASTIC-BISQUE
	0H1208B	2	RF COVER PLATE-PLASTIC-GREY
(2) 28	0G33350ST0R	1	FRONT DISCHARGE WRAP 1.6L C1

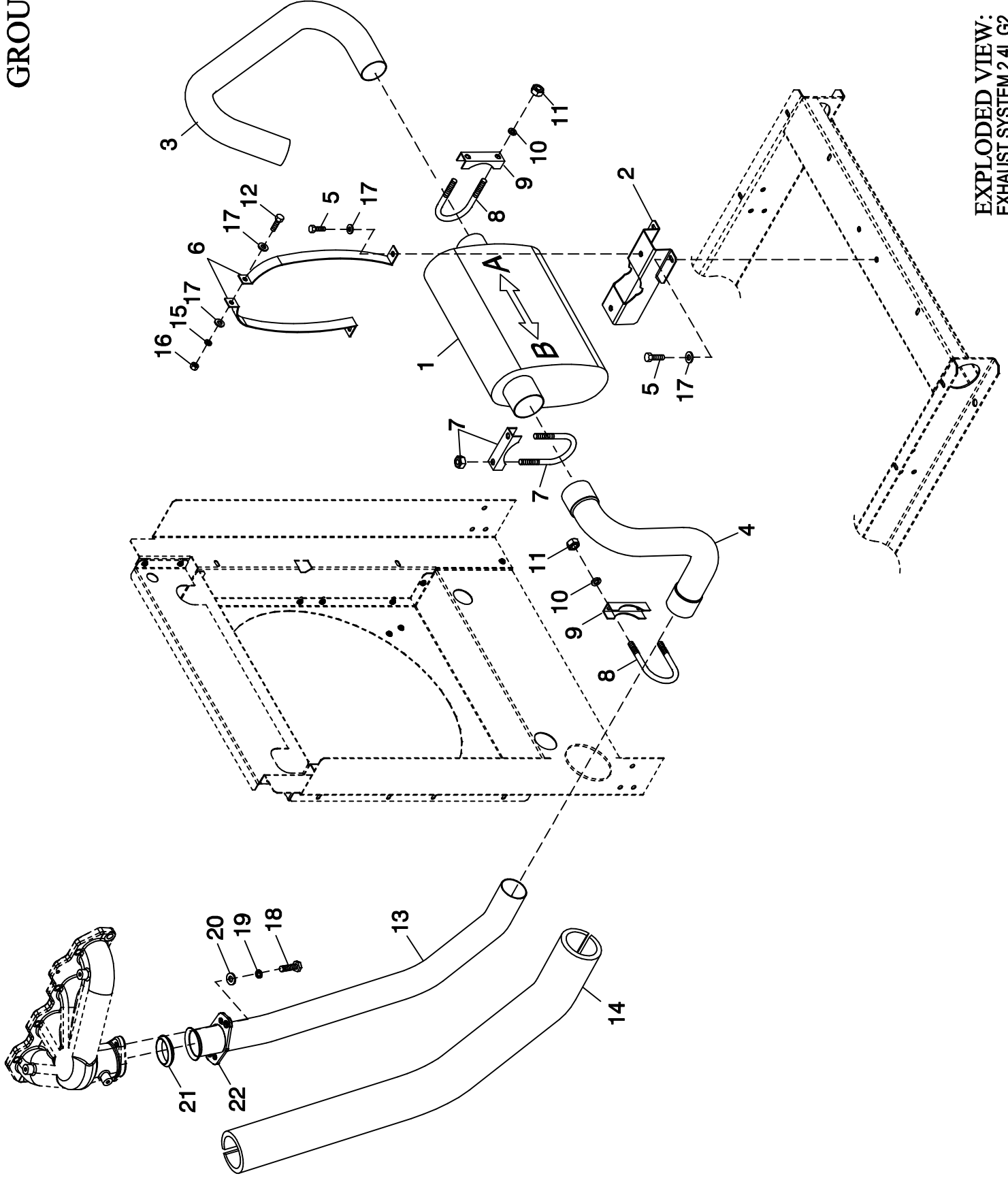
(1) ALUMINUM ENCLOSURE NOTE: ALL ROOF PANELS ARE TO BE SECURED USING ITEM NUMBERS 10 (THREAD FORMING FASTENER) & 3 (LOCK NUT). THE LOCK NUT IS TO BE INSTALLED AFTER THREAD FORMING FASTENER HAS PENETRATED THROUGH EXTRUSIONS IN ENCLOSURE PANELS.

(2) SHEET METAL PARTS LISTED IN THE BOM TABLE ARE REPRESENTING GENERIC PARTS (NO COLOR).

- MANUFACTURING: FOR CORRECT MATERIAL AND COLOR REFER TO AS400 BOM.
- CUSTOMER: FOR CORRECT MATERIAL AND COLOR OF REPLACEMENT PARTS REFER TO "REPLACEMENT SHEET METAL PARTS ORDERING GUIDE-0H7169" INCLUDED IN THE MANUAL OR AVAILABLE ON THE GENERAC WEBSITE.

(3) USED ON 1.6L UNITS ONLY.

# GROUP F



EXPLODED VIEW:  
EXHAUST SYSTEM 2.4L G2  
DRAWING #: 0G8890

**EXPLODED VIEW: EXHAUST SYSTEM 2.4L G2****DRAWING #: 0G8890****GROUP F**

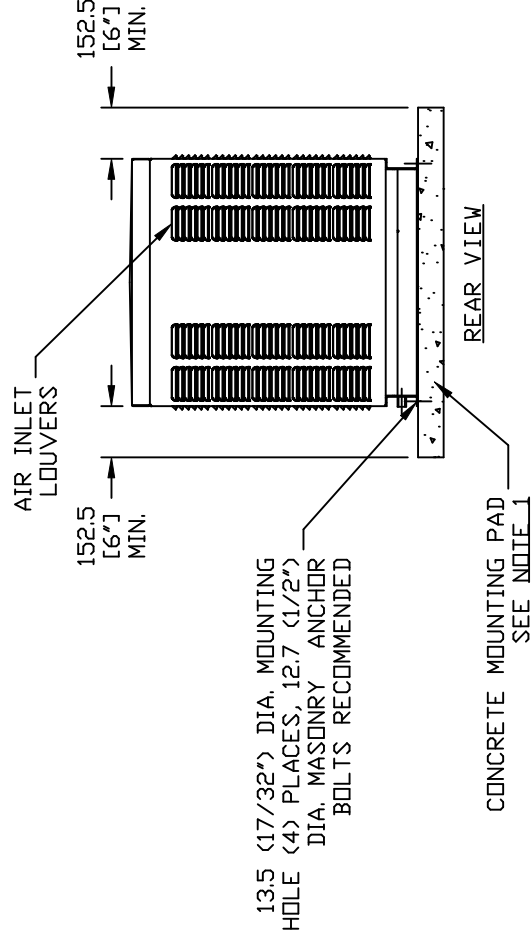
APPLICABLE TO:

<b>ITEM</b>	<b>PART #</b>	<b>QTY.</b>	<b>DESCRIPTION</b>
1	0F7366	1	MUFFLER C1
2	0F7647	1	MUFFLER SADDLE
3	0F8095	1	PIPE EXHAUST OUTLET
4	0G8614	1	EXHAUST ELBOW 2.4L G2
5	0E3257	4	SCREW HWHTF M6-1.0 X 16
6	0F7644	2	MUFFLER STRAP
7	0C6119	1	BOLT U 5/16-18 X 2-1/4
8	036434	2	BOLT U 5/16-18 X 2.09
9	036449	2	SADDLE 2 INCH
10	022129	4	WASHER LOCK M8-5/16
11	022259	4	NUT HEX 5/16-18 STEEL
12	038750	1	SCREW HHC M6-1.0 X 30 G8.8
13	0G8613	1	EXHAUST PIPE 2.4L G2
14	0F3794B	1	EXHAUST BLANKET 700MM LONG
15	022097	1	WASHER LOCK M6-1/4
16	049813	1	NUT HEX M6 X 1.0 G8 YEL CHR
17	022473	6	WASHER FLAT 1/4-M6 ZINC
18	0D2611	2	SCREW HHC 3/8-16 X 1-3/4 SS
19	085917	2	WASHER LOCK 3/8 SS
20	088775	2	WASHER FLAT 3/8 SS
21	044149	1	GASKET EXHAUST RING
22	0E8816	1	FLANGE EXHAUST 2" PIPE

# GROUP G

**NOTES:**

- 1) MINIMUM RECOMMENDED CONCRETE PAD SIZE: 1041 (41.0") WIDE X 1892 (74 1/2") LONG. REFERENCE INSTALLATION GUIDE SUPPLIED WITH UNIT FOR CONCRETE PAD GUIDELINES.
- 2) ALLOW SUFFICIENT ROOM ON ALL SIDES OF THE GENERATOR FOR MAINTENANCE AND SERVICING, THIS UNIT MUST BE INSTALLED IN ACCORDANCE WITH CURRENT APPLICABLE NFPA 37 AND NFPA 70 STANDARDS AS WELL AS ANY OTHER FEDERAL, STATE AND LOCAL CODES FOR MINIMUM DISTANCES FROM OTHER STRUCTURES.
- 3) CIRCUIT BREAKER INFORMATION:  
SEE SPECIFICATION SHEET WITHIN OWNERS MANUAL.
- 4) INSIDE STUB-UP AREA FOR AC LOAD LEAD CONDUIT CONNECTION, NEUTRAL CONNECTION, BATTERY CHARGER 120 VOLT AC (0.5 AMP MAX.) CONNECTION, ACCESS TO TRANSFER SWITCH CONTROL WIRES, AND TRANSFER SWITCH CONNECTION (IF SO EQUIPPED). REMOVE FRONT COVER FOR ACCESS.
- 4A) ONE 1-1/2" NEMA ELECTRICAL KNOCKOUT AND TWO 1/2" NEMA ELECTRICAL KNOCKOUTS PROVIDED FOR OUTSIDE AC LOAD CONDUIT CONNECTION, NEUTRAL CONNECTION, BATTERY CHARGER 120 VOLT AC (0.5 AMP MAX.) CONNECTION, ACCESS TO TRANSFER SWITCH CONTROL WIRES, AND TRANSFER SWITCH CONNECTION (IF SO EQUIPPED). REMOVE FRONT COVER FOR ACCESS.
- 5) REFERENCE OWNERS MANUAL FOR LIFTING WARNINGS.
- 6) REMOVE LIFT-OFF ENCLOSURE TO ACCESS EXHAUST MUFFLER.



WEIGHT DATA				
ENGINE/KW	ENCLOSURE MATERIAL	WEIGHT (GENSET ONLY) KG [LBS]	WEIGHT (SHIPPING CARTON/SKID) KG [LBS]	SHIPPING WEIGHT (GENSET, SKID, & CARTON) KG [LBS]
2. 4L/22KW	ALUMINUM	383 [843]	30 [66]	413 [909]
2. 4L/27KW	ALUMINUM	405 [891]		434 [957]

EXPLODED VIEW:  
INSTALLATION DRAWING C1 CPL  
DRAWING #: 0G9370

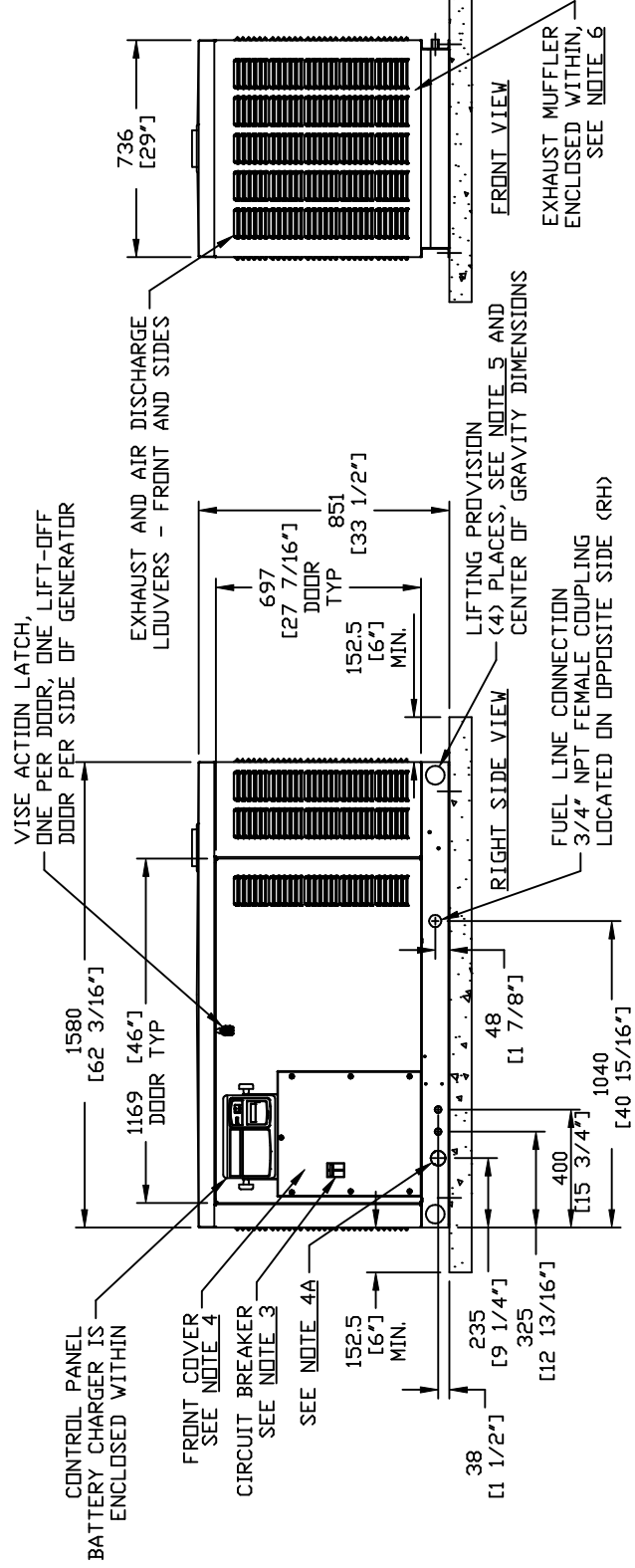
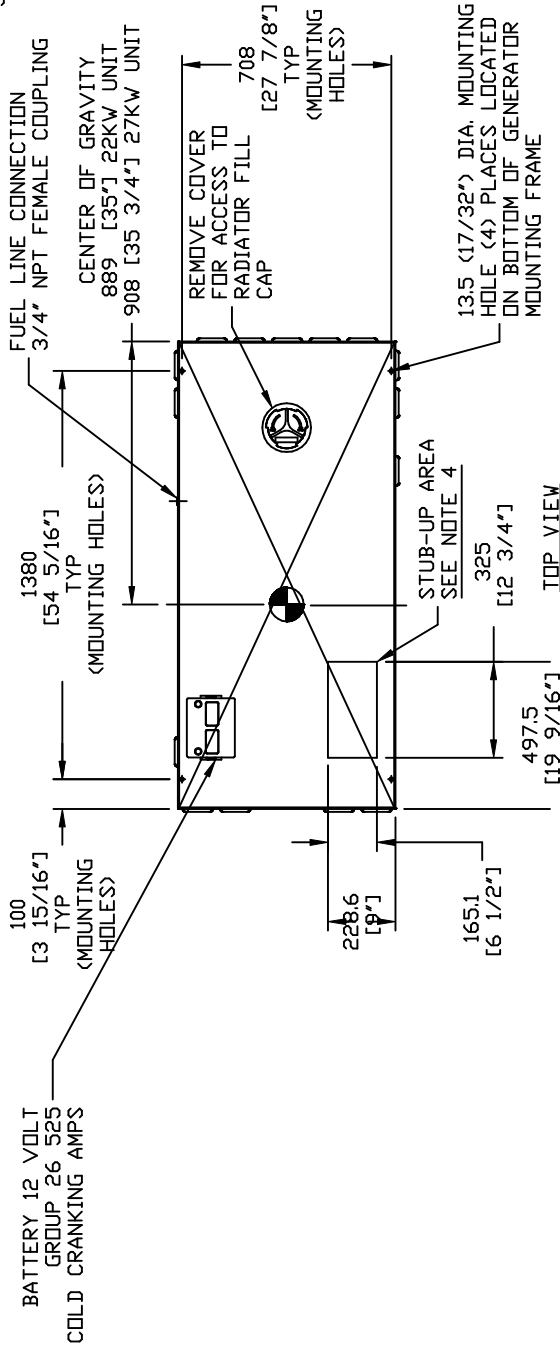


# GROUP G

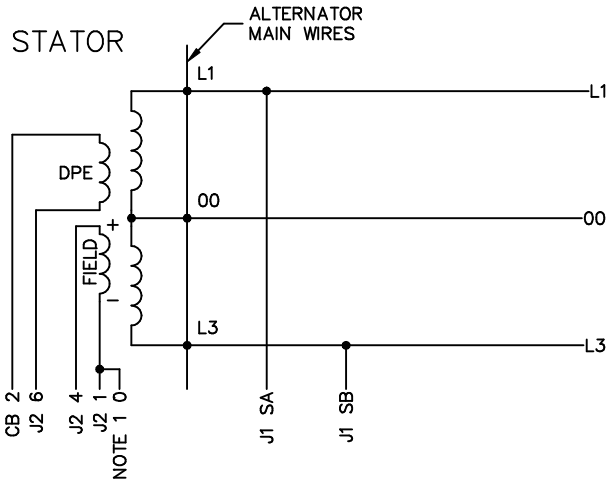
SERVICE ITEM ACCESSIBILITY CHART

SERVICE ITEM	ACCESS
OIL FILL CAP	THRU RIGHT DOOR
OIL DIP STICK	THRU RIGHT DOOR
OIL FILTER	THRU RIGHT DOOR
OIL DRAIN HOSE	THRU LEFT DOOR
RADIATOR DRAIN HOSE	THRU LEFT DOOR
AIR CLEANER ELEMENT	THRU LEFT DOOR
SPARK PLUGS	THRU LEFT DOOR
MUFFLERS	SEE NOTE 6
FAN BELT	THRU RIGHT DOOR
BATTERY	THRU LEFT DOOR

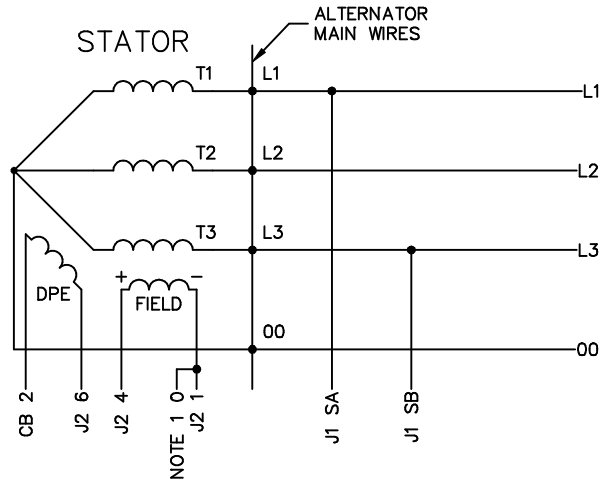
REFERENCE OWNERS MANUAL  
FOR PERIODIC REPLACEMENT  
PART LISTINGS



EXPLODED VIEW:  
INSTALLATION DRAWING C1 CPL  
DRAWING #: 0G9370



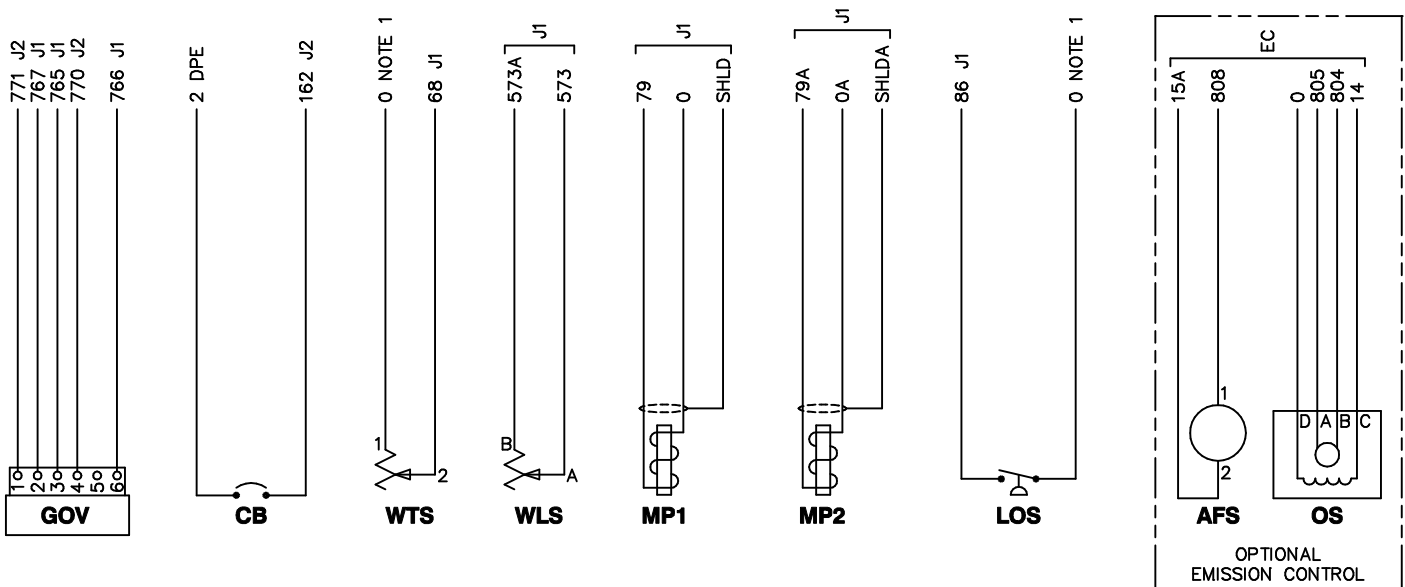
ALTERNATOR CONNECTIONS FOR 1Ø UNITS

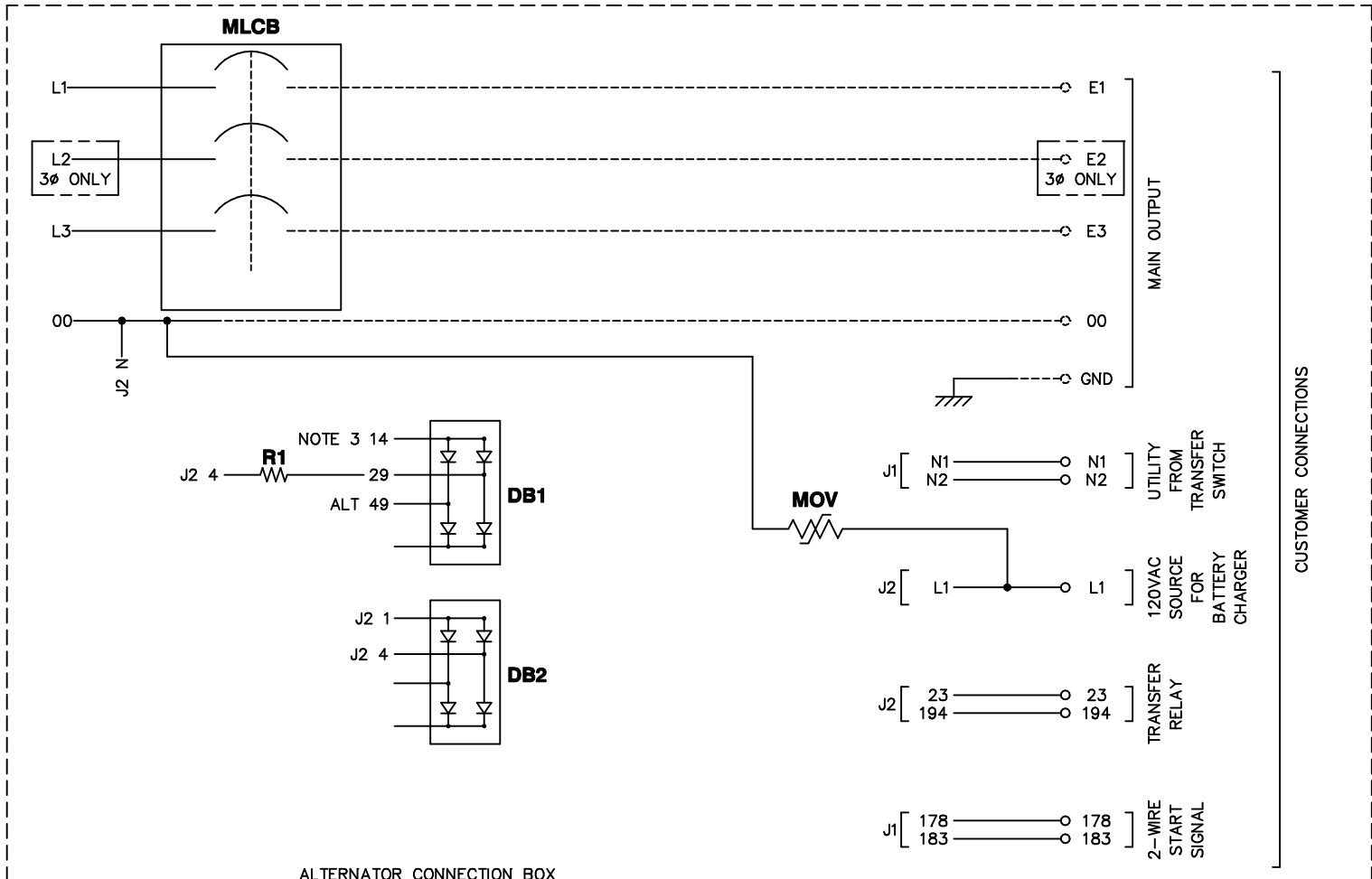


ALTERNATOR CONNECTIONS FOR 3Ø UNITS

ALTERNATOR CONNECTION BOX

GENERATOR SET

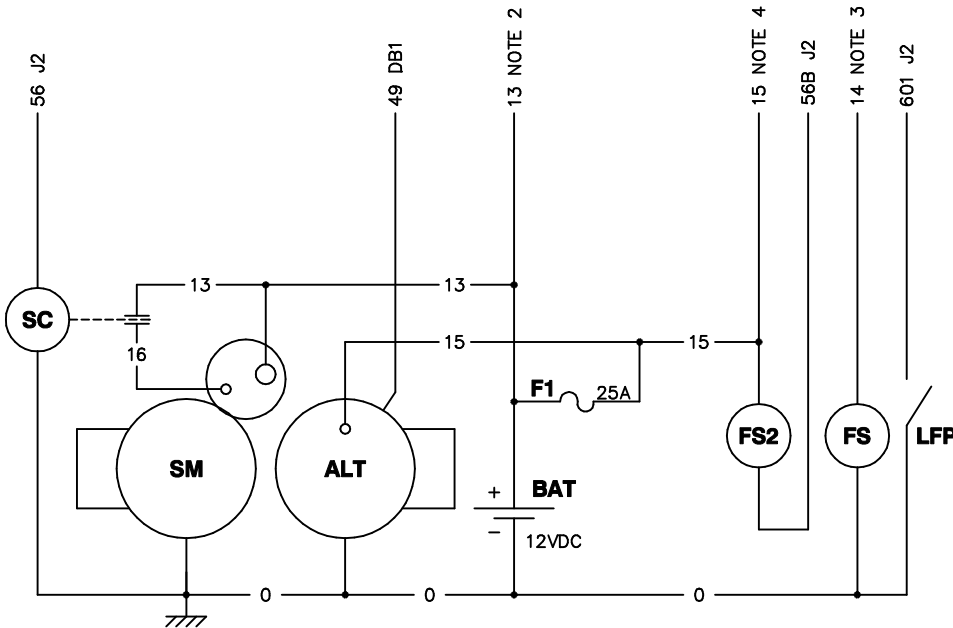




ALTERNATOR CONNECTION BOX

GENERATOR SET

NOTE:  
FOR FIELD WIRING TO CUSTOMER CONNECTIONS  
(TERMINAL BLOCKS)  
MAXIMUM WIRE SIZE: #12 AWG



**NOTES:**

- 1) WIRE #0 IS CHASSIS GROUND (BATTERY-) UNLESS NOTED OTHERWISE.
- 2) WIRE #13 IS UNFUSED +12VDC (BATTERY+).
- 3) WIRE #14 IS FUSED +12VDC WHEN GENERATOR IS CRANKING OR RUNNING.
- 4) WIRE #15 IS FUSED +12VDC FOR GENERAL USE.
- 5) WIRE #15A IS FUSED +12VDC FOR THE AIR/FUEL SOLENOID OPTION AND FOR THE IGNITION COILS.

**BWR CONNECTOR**

PIN	WIRE	TO	FUNCTION
1	820	J1-12	+5V POWER FOR BASIC REMOTE
2	817	J1-4	REMOTE DISPLAY SYSTEM READY
3	818	J1-5	REMOTE DISPLAY ALARM
4	819	J1-17	REMOTE DISPLAY MAINTENANCE
5	0	GND	NOTE 1

**EC CONNECTOR**

PIN	WIRE	TO	FUNCTION
1	0	GND	NOTE 1
2	14	J2-8	NOTE 3
3	15A	J2-23	NOTE 5
4	808	J2-2	AIR/FUEL RATIO SOLENOID DRIVER
5	805	J1-35	OXYGEN SENSOR RETURN
6	804	J1-34	OXYGEN SENSOR +

**ENGINE CONTROL MODULE CONNECTIONS**

**J1**

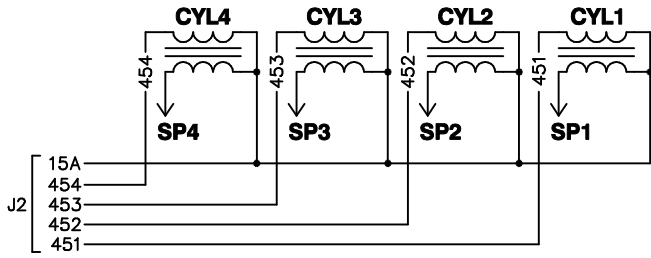
PIN	WIRE	TO	FUNCTION
1	178	CUST CON	REMOTE START RETURN
4	817	BWR-2	REMOTE DISPLAY SYSTEM READY
5	818	BWR-3	REMOTE DISPLAY ALARM
6	15	F1	NOTE 4
7	15	F1	NOTE 4
8	0	GND	NOTE 1
9	0	GND	NOTE 1
10	0	MP1-2	FLYWHEEL SENSOR -
11	0A	MP2-2	CAM SENSOR -
12	820	BWR-1	+5V POWER FOR BASIC REMOTE
13	SA	MLCB	OUTPUT VOLTAGE SENSING A
14	183	CUST CON	REMOTE START
15	SHLDA	MP2-1	CAM SENSOR DRAIN
16	SHLD	MP1-1	FLYWHEEL SENSOR DRAIN
17	819	BWR-4	REMOTE DISPLAY MAINTENANCE
18	767	GOV-2	THROTTLE POSITION FEEDBACK RETURN
19	765	GOV-3	THROTTLE POSITION FEEDBACK SOURCE
20	766	GOV-6	THROTTLE POSITION FEEDBACK SIGNAL
21	68	WTS-2	COOLANT TEMP SIGNAL
22	79A	MP2-3	CAM SENSOR +
23	79	MP1-3	FLYWHEEL SENSOR +
24	SB	MLCB	OUTPUT VOLTAGE SENSING B
25	N1	CUST CON	UTILITY VOLTAGE SENSING 1
26	N2	CUST CON	UTILITY VOLTAGE SENSING 2
31	573A	WLS-B	COOLANT LEVEL SIGNAL RETURN
32	573	WLS-A	COOLANT LEVEL SIGNAL
33	86	LOS-NC	LOW OIL PRESSURE SIGNAL
34	804	EC-6	OXYGEN SENSOR +
35	805	EC-5	OXYGEN SENSOR RETURN

**J2**

PIN	WIRE	TO	FUNCTION
1	770	GOV-4	THROTTLE DRIVE HI
2	808	EC-4	AIR/FUEL RATIO SOLENOID DRIVER
3	56B	FS2	STARTING FUEL SOLENOID CONTROL
4	451	CYL1	IGNITION COIL DRIVE 1
5	452	CYL2	IGNITION COIL DRIVE 2
6	453	CYL3	IGNITION COIL DRIVE 3
7	454	CYL4	IGNITION COIL DRIVE 4
8	14	DB1/FS/EC-2	NOTE 3
9	771	GOV-1	THROTTLE DRIVE LO
12	23	CUST CON	TRANSFER RELAY COIL CONTROL
13	194	CUST CON	TRANSFER RELAY COIL +
14	601	LFP	LOW FUEL PRESSURE
16	6	DPE	EXCITER RETURN
17	162	CB	EXCITER OUTPUT (BREAKER PROTECTED)
18	4	FIELD	FIELD (BRUSH) +
19	1	FIELD	FIELD (BRUSH) -
20	L1	CUST CON	120VAC SOURCE FOR BATTERY CHARGER
21	N	00	NEUTRAL
22	56	SC	STARTER CONTACTOR DRIVER
23	15A	EC-3/CYL1-CYL4	NOTE 5

**LEGEND**

00 - NEUTRAL	EC - EMISSIONS CONNECTOR	MP_ - MAGNETIC PICKUP
AFS - AIR/FUEL SOLENOID	F1 - FUSE INLINE	OS - OXYGEN SENDER
ALT - DC CHARGE ALTERNATOR	FS_ - FUEL SOLENOID	R1 - RESISTOR
BAT - BATTERY	GOV - ELECTRONIC GOVERNOR ACTUATOR	SC - STARTER CONTACTOR
BWR - BASIC WIRELESS RECEPTACLE	J_ - ENGINE CONTROL MODULE CONNECTOR	SHLD - SHIELD
CB - CIRCUIT BREAKER	LFP - LOW FUEL PRESSURE SWITCH	SM - STARTER MOTOR
CYL_ - CYLINDER IGNITION COIL	LOS - LOW OIL PRESSURE SWITCH	SP_ - SPARK PLUG
DB_ - DIODE BRIDGE	MLCB - MAIN LINE CIRCUIT BREAKER	WLS - COOLANT LEVEL SENDER
DPE - EXCITER	MOV - METAL OXIDE VARISTOR	WTS - COOLANT TEMPERATURE SENDER



### LEGEND

- |   |   |
|---|---|
| AFS - AIR/FUEL SOLENOID                   | J1 - ENGINE CONTROL MODULE 35-PIN CONNECTOR |
| ALT - DC CHARGE ALTERNATOR                | J2 - ENGINE CONTROL MODULE 23-PIN CONNECTOR |
| AS - ALTERNATOR STATOR                    | LFP - LOW FUEL PRESSURE SWITCH              |
| BA - BRUSH ASSEMBLY                       | LOS - LOW OIL PRESSURE SWITCH               |
| BAT - BATTERY                             | LVP - LOW VOLTAGE PLUG 8-PIN (BULKHEAD)     |
| BWR - BASIC WIRELESS RECEPTACLE           | LVR - LOW VOLTAGE RECEPTACLE 8-PIN          |
| CB - CIRCUIT BREAKER                      | MLCB - MAIN LINE CIRCUIT BREAKER            |
| CYL - CYLINDER IGNITION COIL              | MOV - METAL OXIDE VARISTOR                  |
| DB - DIODE BRIDGE                         | MP - MAGNETIC PICKUP                        |
| EC - EMISSIONS CONNECTOR                  | NB - NEUTRAL BLOCK                          |
| F1 - FUSE INLINE (25A ATO)                | OS - OXYGEN SENDER                          |
| FS - FUEL SOLENOID                        | R1 - RESISTOR                               |
| FSP - FUEL SOLENOID PLUG                  | SC - STARTER CONTACTOR                      |
| FSR - FUEL SOLENOID RECEPTACLE            | SM - STARTER MOTOR                          |
| GND - GROUND CONNECTION                   | TB - TERMINAL BLOCK, CAGE CLAMP             |
| GOV - ELECTRONIC GOVERNOR ACTUATOR        | WLS - COOLANT LEVEL SENDER                  |
| HVP - HIGH VOLTAGE PLUG 12-PIN (BULKHEAD) | WTS - COOLANT TEMPERATURE SENDER            |
| HVR - HIGH VOLTAGE RECEPTACLE 12-PIN      |   |

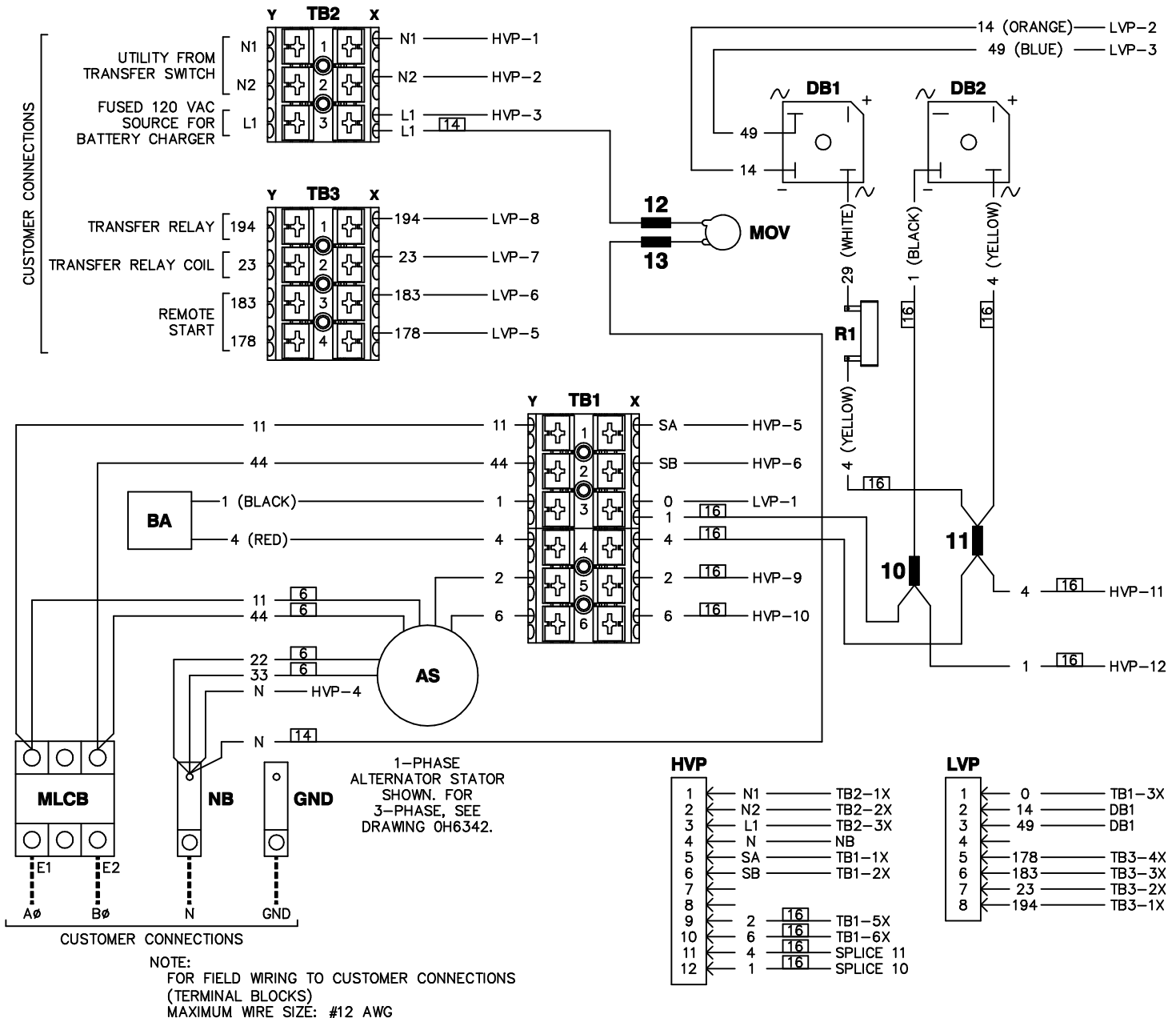
NOTE: ALL WIRES 18 AWG  
300V UL LISTED UNLESS  
SHOWN OTHERWISE

SPLICE NUMBER

WIRE SPLICE

NOTE: ALL WIRES ON THIS  
PAGE ARE 600V RATED

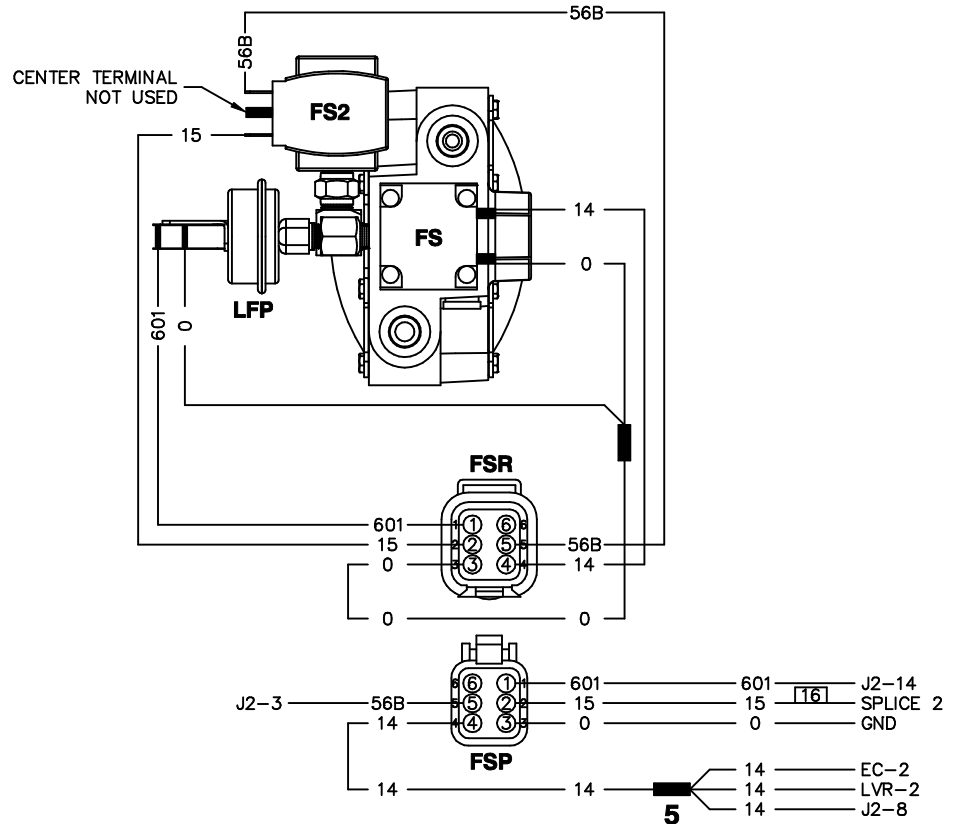
### COMPONENTS LOCATED IN CUSTOMER CONNECTION BOX



COMPONENTS LOCATED ON ENGINE

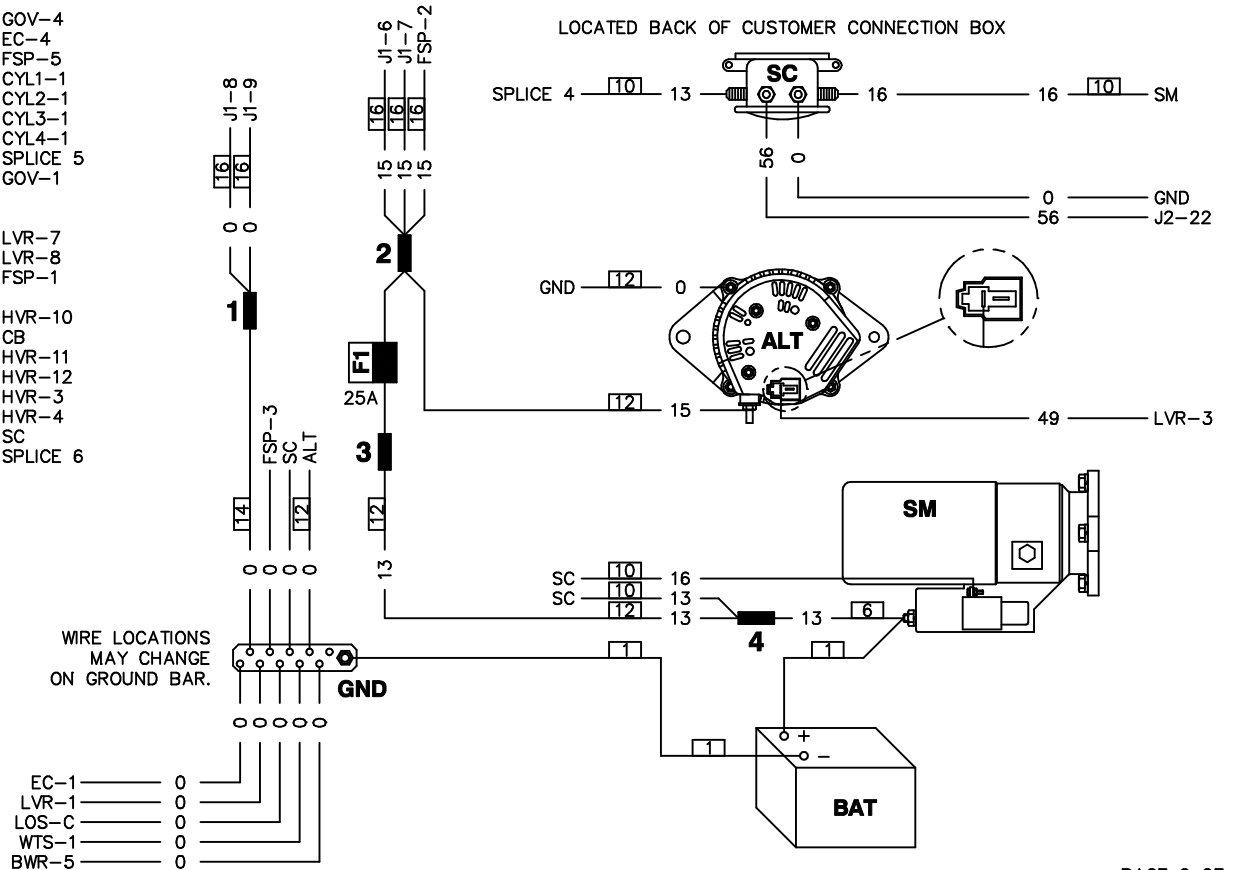
**J1**

1	178	LVR-5
2		
3		
4	817	BWR-2
5	818	BWR-3
6	15	SPLICE 2
7	15	SPLICE 2
8	0	SPLICE 1
9	0	SPLICE 1
10	0	MP1-2
11	0A	MP2-2
12	820	BWR-1
13	SA	HVR-5
14	183	LVR-6
15	SHLDA	MP2-1
16	SHLD	MP1-1
17	819	BWR-4
18	767	GOV-2
19	765	GOV-3
20	766	GOV-6
21	68	WTS-2
22	79A	MP2-3
23	79	MP1-3
24	SB	HVR-6
25	N1	HVR-1
26	N2	HVR-2
27		
28		
29		
30		
31	573A	WLS-B
32	573	WLS-A
33	86	LOS-NC
34	804	EC-6
35	805	EC-5



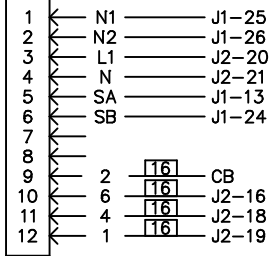
**J2**

1	770	GOV-4
2	808	EC-4
3	56B	FSP-5
4	451	CYL1-1
5	452	CYL2-1
6	453	CYL3-1
7	454	CYL4-1
8	14	SPLICE 5
9	771	GOV-1
10		
11	23	LVR-7
12	194	LVR-8
13	601	FSP-1
14		
15		
16	6	HVR-10
17	162	CB
18	4	HVR-11
19	1	HVR-12
20	L1	HVR-3
21	N	HVR-4
22	56	SC
23	15A	SPLICE 6

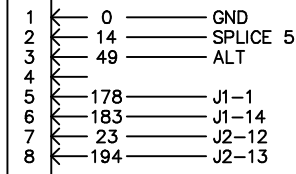


## COMPONENTS LOCATED ON ENGINE

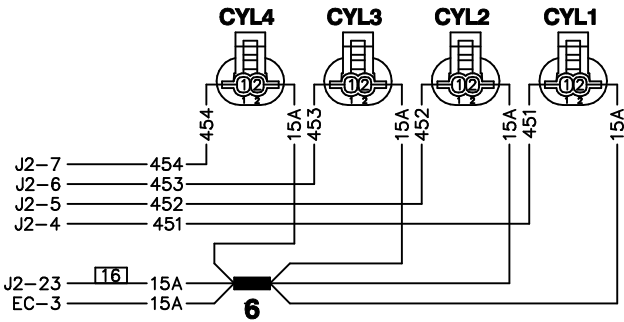
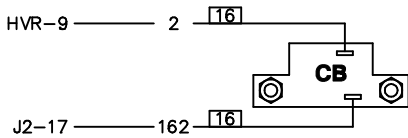
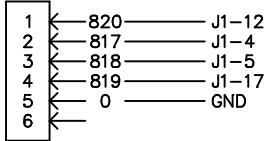
### HVR



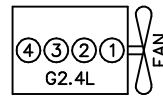
### LVR



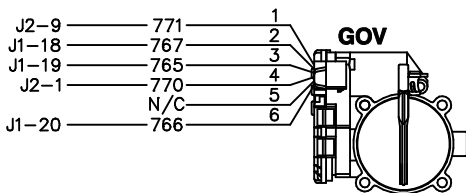
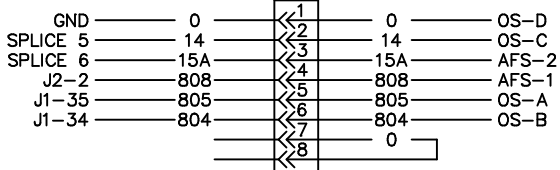
### BWR



ENGINE BLOCK TOP VIEW

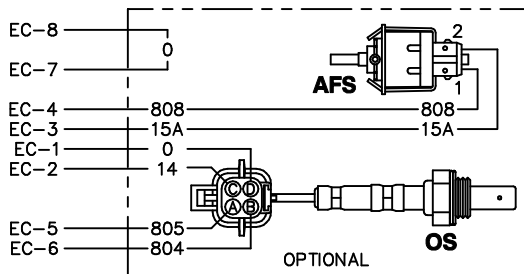
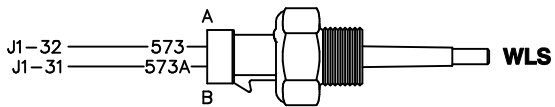
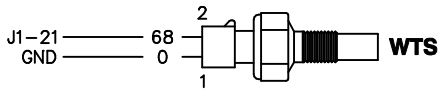
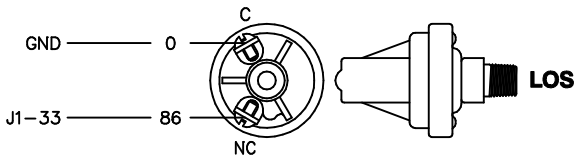
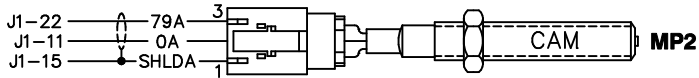
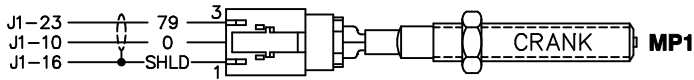


### EC

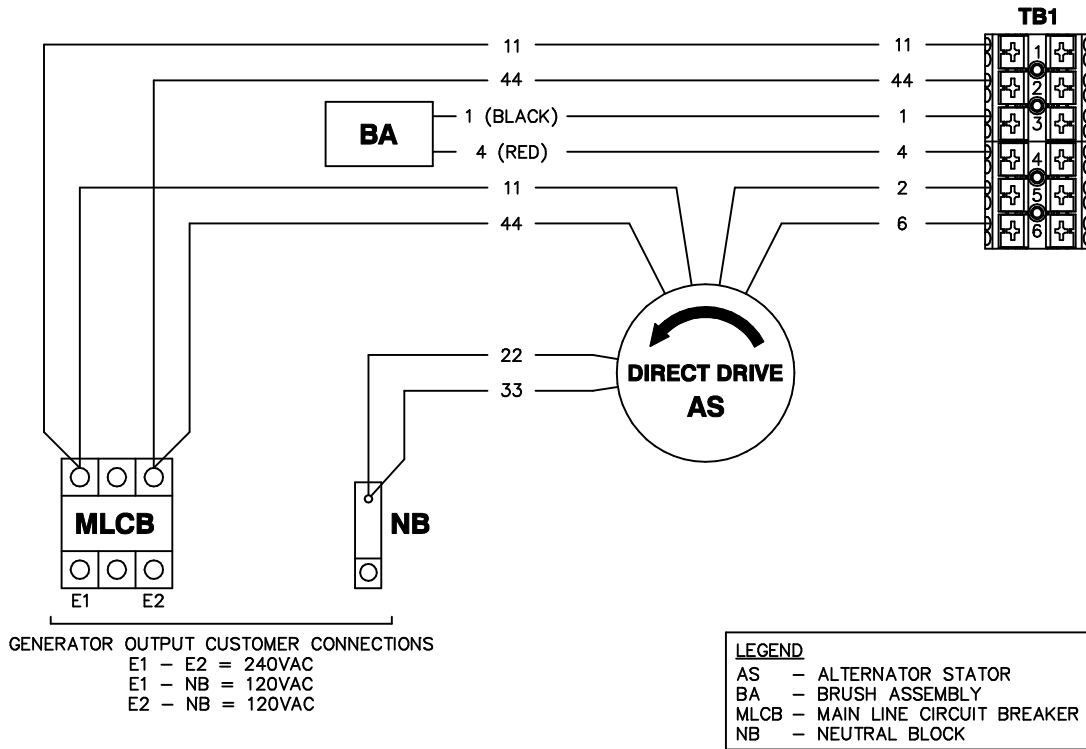




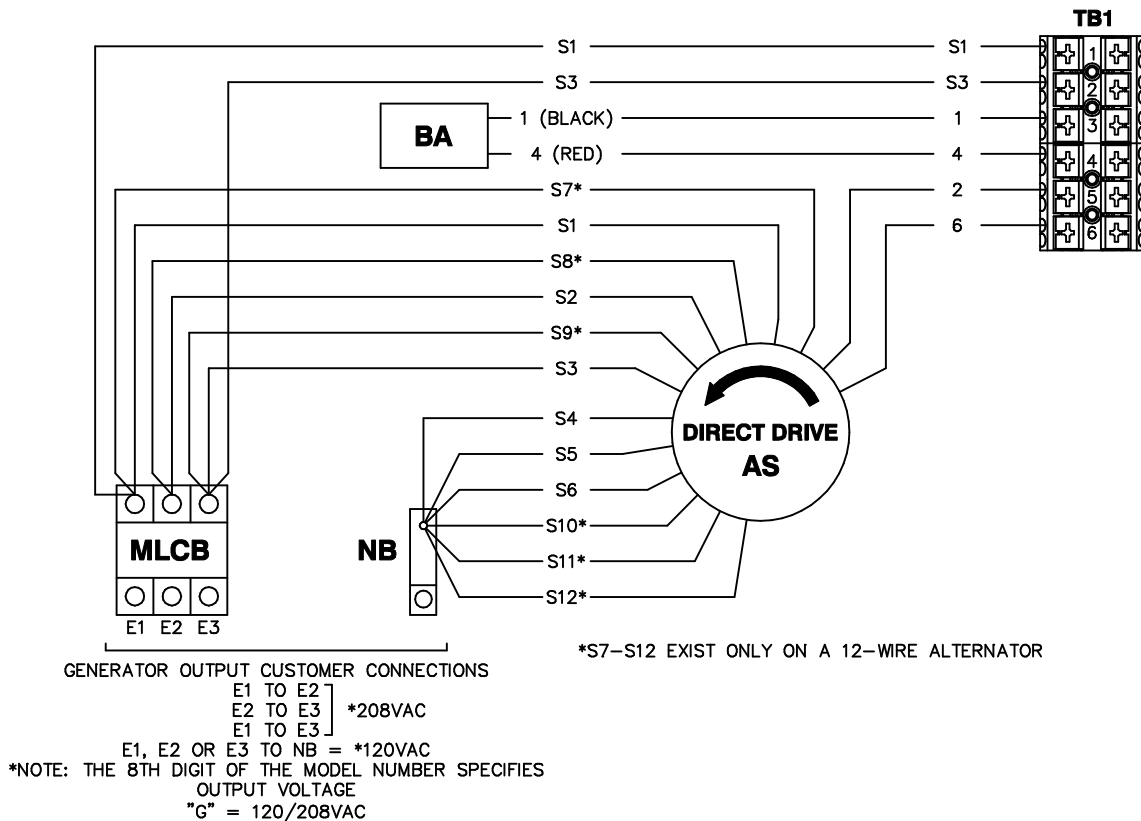
COMPONENTS LOCATED ON ENGINE



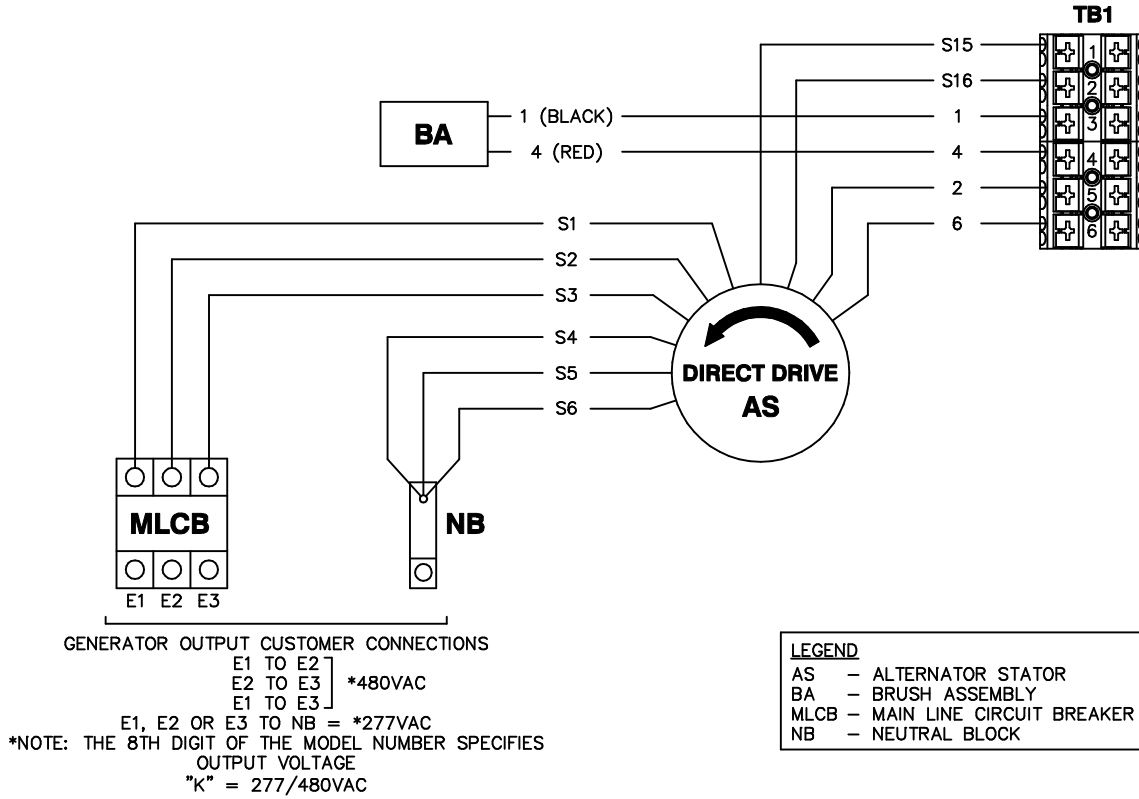
**OPTION 1 - SINGLE PHASE, NEXUS CONTROL PANEL, 240V**



**OPTION 2 - THREE PHASE, NEXUS CONTROL PANEL, 120/208**



**OPTION 3 - THREE PHASE, NEXUS CONTROL PANEL, 6-WIRE 277/480V**



**OPTION 4 - THREE PHASE DELTA, NEXUS CONTROL PANEL, 7-WIRE 120/240V**

