

INSTALLATION MANUAL

# Cascade<sup>®</sup> Series

## WHOLE HOUSE FAN SYSTEMS

MODELS: CA2, CA3, CA4, CA5



### ITEMS INCLUDED:

- Fan Assembly with steel support straps, hardware and 20 foot power cord
- Duct Support Straps & hardware
- Acoustic Flex Duct, 7 foot length with collars
- Gravity Damper Assembly
- "Eggcrate" style Inlet Grille (white) with mounting screws
- Wall Mount Controls with 2-Speed On/Off Switch, white decora wall plate and plastic single gang wall box.

This device MUST be installed by a qualified agency in accordance with the manufacturer's installation instructions. The definition of a qualified agency is: any individual, firm, corporation or company which either in person or through a representative is engaged in, and is responsible for, the installation and operation of HVAC appliances, who is experienced in such work, familiar with all the precautions required, and has complied with all the requirements of the authority having jurisdiction.

Please retain these instructions after installation.

Installed By: \_\_\_\_\_ Phone: \_\_\_\_\_ Installation Date: \_\_\_\_\_

**CASCADE**<sup>™</sup>  
*Series*

(THIS PAGE LEFT INTENTIONALLY BLANK)

Thank you for purchasing a Cascade® ducted Whole House Fan. This fan has been designed to provide many years of natural, quiet, and energy-efficient cooling.

Please take a few minutes to read over this manual and its accompanying documents to make sure you are prepared to install the Whole House Fan system. In particular:

- The homeowner/resident should read the **WHERE TO LOCATE** section so that the fan will be correctly located to maximize its effectiveness and efficiency.
- The **VENTILATION REQUIREMENTS** section is also particularly important, as it describes the minimum attic ventilation necessary to operate the fan.
- The **INSTALLATION: GRAVITY DAMPER** section contains important information regarding the constraints within which this fan's gravity damper must be installed.

The Eggcrate Inlet Grille and Gravity Damper Assemblies come in different size openings. Verify which gravity damper component design is part of your Whole House Fan Assembly by actual measurement of the gravity damper opening section before beginning installation of gravity damper section.

Before installing this fan, inspect it and all of its parts for any damage it may have sustained during shipping. **DO NOT INSTALL DAMAGED EQUIPMENT.** If you suspect this fan has been damaged during shipping, contact your retailer.

Whole House Fans are designed to be installed within a home's attic, which makes them and their sub-components difficult to access once installed. **TEST THIS FAN OUTSIDE OF THE ATTIC BEFORE INSTALLING IT PERMANENTLY.**

## SAFETY CONSIDERATIONS



Some of the principles of safe installation and operation of this product are not immediately obvious. Read the following safety information before continuing further:

- Never operate this fan without a window or door opened.
- This fan is meant for general ventilation. It has NOT been designed to ventilate particle laden and/or explosive mixtures of air and must NOT be used for such.
- This fan is NOT for use in kitchens
- Before installing or servicing this fan, switch power off at the home's electrical panel to reduce the risk of damaging circuit boards, fire, electrical shock, or injury.
- Install this fan in accordance with this manual and all local codes and standards.

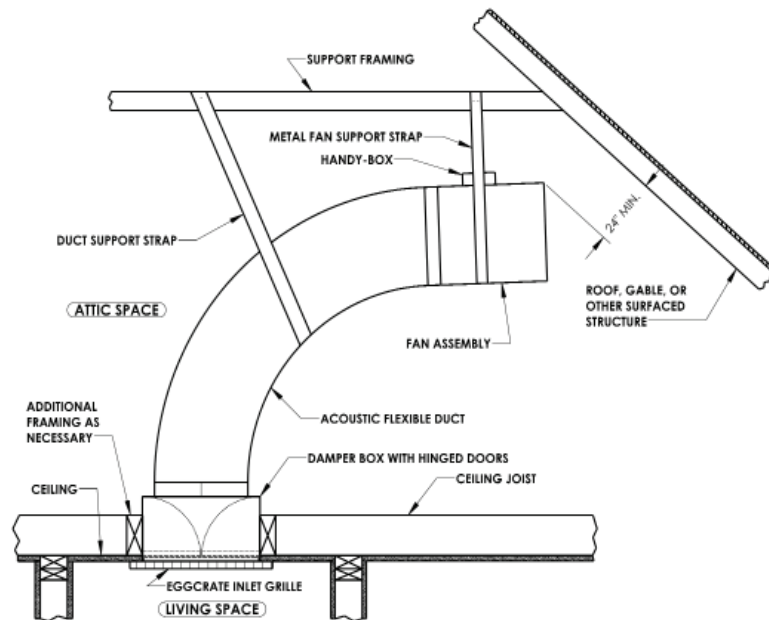

## GRAVITY DAMPER INFORMATION

The Cascade Series fan systems include gravity-closed gravity damper doors that are opened by air pressure created by fan operation. The dampers serve to block entry of air from the attic into the living space, and are provided with foam sealing and insulating material in the doors to reduce heat transfer from the attic space.



**The Cascade Series Whole House Fan Systems have different gravity damper sizes, depending on the specific model to be installed. Verify which gravity damper size is provided with your system prior to beginning installation of the product.**

## ELECTRICAL REQUIREMENTS

The Cascade Series Whole-House Fan Systems require a 115 volt electrical power supply of minimum 15A ampacity and maximum 15 Amp circuit overcurrent protection. We strongly recommend providing a dedicated circuit for this fan system.

All electrical components, whether included with the system or supplied by others, must be rated for the fan system's electrical load requirements; please refer to the Cascade Series specifications table for the electrical load requirements of the specific model to be installed.

All wiring and connections must be made according to this manual and all applicable electrical wiring codes and standards. All applicable electrical codes must be followed to the satisfaction of the local authority having jurisdiction.

Cascade Series Whole-House Fan Systems are shipped with a pre-wired 20 foot 115V power cord that may be used to operate the fan by means of a switched or remote-controlled 115V grounded outlet mounted in the attic. A wall switch rated for the fan system's electrical load requirements may be mounted in the living space and used for simple single-speed control of the fan. The power cord is pre-wired to operate the fan on high speed only but may be re-wired for low speed operation if desired; please refer to the appropriate wiring diagrams for further information. If a remote-controlled outlet is used for fan control, the remote outlet must be rated for the electrical load requirements of the specific model to be installed.

Cascade Series Whole-House Fan Systems include wall mount electrical control components including a multi-speed switch, a white Decora duplex wall plate, and plastic single gang wall box. These controls may be installed to provide multi-speed control of the fan from within the living space. Please refer to the appropriate wiring diagrams for further information on the proper wiring configuration: either 2 speed hardwired or single speed operation using pre-wired power cord.

# VENTILATION REQUIREMENTS

It is very important that the attic be sufficiently ventilated for the fan system to operate properly. Without adequate ventilation, hot air exhausted from the home cannot easily escape from the attic, which creates back-pressure that will substantially reduce the fan's performance. Operating this fan in an attic with less net free ventilation area than recommended will decrease its airflow and energy efficiency.

**If subject to the California Title 24 requirements for whole-house fan ventilation, the fan system must be installed to the minimum ventilation requirements as found in the standard.**

**In the absence of applicable local code regarding whole-house ventilation, we recommend a minimum of 1 square foot of "net free" ventilation area per 500 cfm at a fan's highest speed for proper operation. Refer to specification table for required Net Free Ventilation Area in Attic at HVI fan rating.**

**Net Free Ventilation Area can be provided by any combination of gable, eyebrow, roof cap, soffit, or ridge vents, or any other method of ventilating the attic space. The openings of most vents are partially obstructed by grilles, louvers, and/or screens. A vent's "net free" ventilation area is the surface area of its opening minus the surface area of any grilles, louvers, or screening covering it. Different types of vents have different ratios of net free area to total area.**

**While most properly constructed homes have adequately ventilated attics, not all do. Because sufficient ventilation is a very strong factor in this fan's performance, it is important that the home's existing ventilation be verified before it is installed.**

**Manufacturers typically publish their vents' net free ventilation areas and/or ratios in their products' specification documents. If this information is unavailable, a ratio of 50% net free area to total area is usually a good rule of thumb. A notable exception to this rule of thumb are ridge vents. The industry standard net free ventilation area for ridge vents is 13% of the vent's length in feet.**

**Since most attics have multiple vents, often of different types, it is necessary to count each vent, noting its type and size. Apply the appropriate ratio to the dimensions of each vent to find its net free area, and sum these values to find the attic's total ventilation. An example of how these calculations are made is given in the table below:**

Vent Type	Dimensions	Total Area	Net Free Area Ratio ("NFA")	Net Free Ventilation Area (=Total Area x NFA)
Two Louvers	24" x 24"	$24" \times 24" / 144 = 4 \text{ ft.}^2$	50%	$2 \times 4 \text{ ft.}^2 \times .50 = 4 \text{ ft.}^2$
Ridge	32 feet	n/a	13%	$32 \text{ feet} \times .13 = 4.16 \text{ ft.}^2$
Round Soffit	10" diameter	$3.14 \times 5" \times 5" / 144 = .55 \text{ ft.}^2$	50%	$.55 \text{ ft.}^2 \times .50 = 0.28 \text{ ft.}^2$
Total Net Free Ventilation Area:				8.44 ft. <sup>2</sup>

Please consult a roofing professional if the attic's net free ventilation area remains uncertain. Additional ventilation may be required for proper operation of the fan system.

**Refer to specification table for required minimum Open Window Ventilation Area in square feet when operating whole house fan. Without adequate Open Window Ventilation Area, the quantity of cooler air pulled into the home to be exhausted to the attic may substantially reduce the fans overall performance.**

## WHERE TO LOCATE THIS FAN

The best location for this fan is determined by an understanding of its theory of operation: As a home heats up during the day, a large amount of heat is retained in its structure and contents. These materials give up their heat slowly and, in doing so, continue to heat the home's interior even though the outdoor temperature may, in fact, be very comfortable in the evening and at night. Thus, homeowners are forced to either endure the hot conditions inside of their homes or turn on their air conditioners and bear the expense thereof.

When operated properly, this whole house fan can resolve this dilemma by forcing the hot air inside a home out and drawing cool air from outside in. The illustration to the right depicts how this fan exhausts hot air into the attic and draws cool air into the house from outdoors through open windows and/or doors.

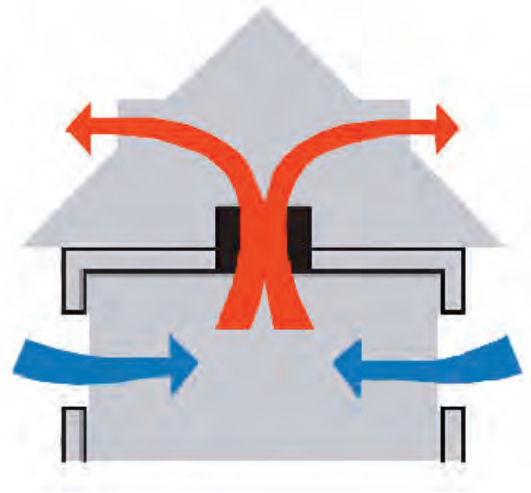

By running this fan through the night, homeowners can extract the maximum possible amount of heat from their home's structure and contents. This essentially "pre-cools" the home ahead of the rise in temperature the next day, which can reduce or even eliminate the need for air conditioning. This Cascade Whole House Fan has been designed specifically for quiet and efficient operation. As such, we strongly recommend homeowners run this fan through the night to reduce their energy expense.

With these principles of operation in mind, adhere to the following guidelines when choosing a location for this fan:

- Locate this fan in a central location, away from windows that will be opened during its operation. Installing this fan centrally promotes an even replacement of air throughout the home, and the longer the path of air travels from an open window to the fan, the greater the cooling effect.
- The damper provided with this fan can only be installed in a horizontal orientation, thereby requiring the unit to be installed in the ceiling.
- Locate this fan at the highest point possible. This exploits natural convection and helps the fan exhaust the hottest indoor air from the home.
- Typically, the ideal location for this fan in a two-story home is in the open area at the top of the stairs.
- Avoid locating this fan in a narrow space or over hard flooring as sound reflecting off of hard surfaces can amplify its perceived noise.
- Even though the Cascade series fan systems are engineered to be extremely quiet, we specifically recommend against installing it in a bedroom as humans' perception of noise is far greater when the surrounding environment is quiet (such as within a bedroom at night).

# INSTALLATION: GRAVITY DAMPER

## GRAVITY DAMPER ORIENTATION NOTE

The ideal orientation of unit's gravity damper is in a level position. If necessary, however, the damper can be installed at a slight angle. TIP: before beginning the installation, make sure that the fan assembly is undamaged, and that the fan blade rotates freely. Brace or clamp the fan assembly to a secure object, and temporarily plug in the fan's power cord into a grounded power outlet to verify smooth and correct operation.



**Be aware that the fan is quite powerful and will draw in loose objects or debris, and will blow dirt, debris and other objects with force!**



**Use eye protection when operating the fan to avoid injury from blowing sand or debris! Keep hands and other objects away from the rotating fan blade!**

TIP: Before beginning the installation, verify that the damper assembly is undamaged, and that the damper doors operate freely, opening and closing fully without binding or restriction.

1. From consideration of the principles of whole-house fan operation, determine the best general area for installation of the gravity damper assembly. The damper assembly is to be mounted in the attic with its bottom edge opening into and flush with the ceiling of the living space. The eggcrate inlet grille is to be mounted on the ceiling of the living space, covering and engaging with the opening of the damper assembly.
2. Using the cardboard from the fan system's packaging, or other suitable material, make a rectangular template for the rough opening of the damper assembly to these dimensions (making sure all sides are at right angles to each other):
  - a. Cascade CA2 and CA3 models: 14-1/4" wide, 22-1/4" long
  - b. Cascade CA4 and CA5 models: 14-1/4" wide, 30-1/4" long

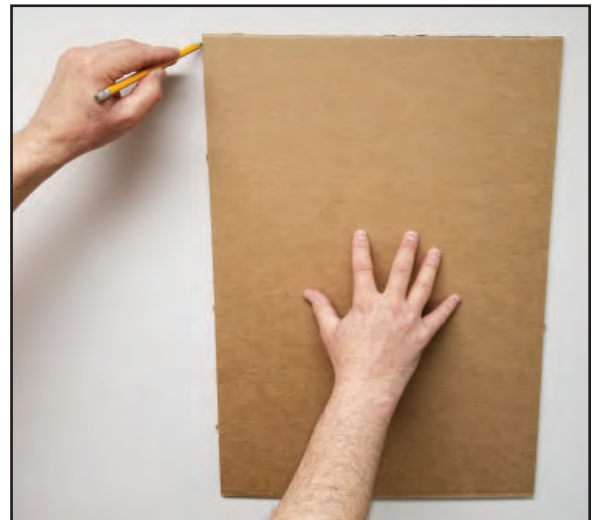

FIGURE 1 - TEMPLATE

3. Take the template into the attic, above the general area for installation, and determine the exact desired location for the rough opening for installation of the damper assembly. There must be at least 36" of vertical clearance above the damper assembly location, and the damper assembly must be fastened to secure framing (ceiling joist, roof truss, or additional framing) along at least one long side or both short sides of the damper assembly! Add additional framing as required to support the weight of the damper assembly and duct.
  - a. For existing construction, the flanges surrounding the opening of the damper assembly may be removed for clearance (as with 16" on-center framing) and/or to allow the side or sides of the damper assembly to make direct contact with the framing used to support the damper assembly. Leave flanges in place if they will not be fastened to framing, if possible. Additional framing may be added after the damper assembly is placed into the rough opening, so the flanges can remain in place if space allows.
  - b. For new construction, before the ceiling drywall is hung, frame in a rough opening for installation of the damper assembly from below. Leave the assembly flanges in place and simply attach the damper assembly to the bottom of the framing using appropriate fasteners installed through the flanges. Skip all following steps regarding cutting the rough opening into the ceiling and proceed with installation of the duct and fan assembly.

4. Make sure that the exact location chosen for the rough opening will allow installation of the eggcrate inlet grille, and will not interfere with any lighting fixtures, smoke alarms, or other objects installed in the ceiling.
5. Remove any insulation from the area of the exact chosen location, and make sure that no wiring, plumbing, bracing or other building elements will interfere with the damper assembly installation.
6. With the template laying on top of the ceiling in the exact chosen location, mark the outline of the template onto the ceiling. If the ceiling hole is to be cut from below, drill or punch a small hole at each corner of the template, and mark the outline of the template from below the ceiling.

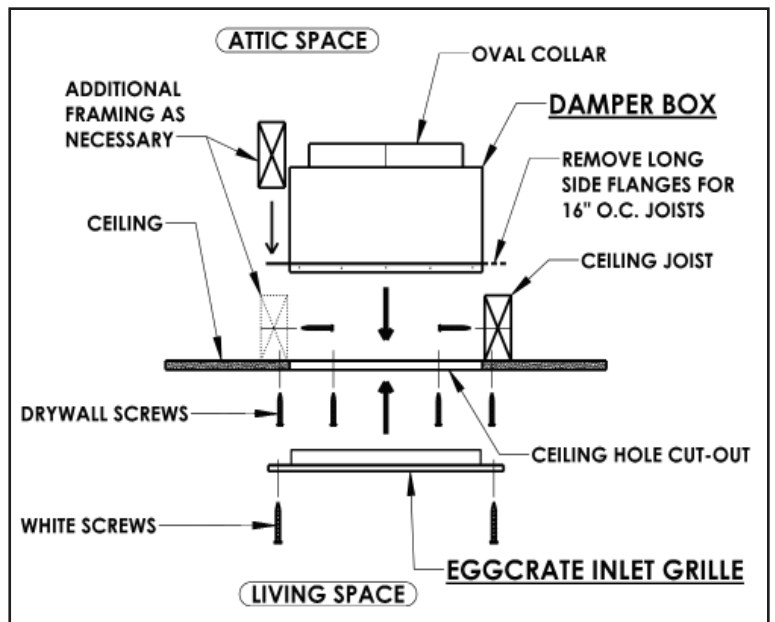

FIGURE 2 - DAMPER BOX INSTALLATION

7. Using a drywall saw or other appropriate device, carefully cut out the rough opening into the ceiling. Use care to avoid damaging the surrounding areas of the ceiling that will not be covered by the edges of the eggcrate inlet grille.
8. Place the fan assembly, flexible duct, and damper assembly in the attic space. If necessary, the fan and damper assemblies may be passed through the rough opening into the attic. It may be necessary to detach the flexible duct from the fan assembly to allow passage of the fan and duct into the attic space. It is recommended to pre-attach the flex ductwork to fan assembly prior to placing unit in attic.
9. Move the damper assembly into place in the rough opening, with the bottom edge of the assembly protruding into the opening. If more than two flanges were removed from the damper assembly for installation clearance, make sure that the bottom edge of the damper assembly does not protrude below the surface of the ceiling.
10. Attach the damper assembly to the framing by installing drywall screws (as supplied) or wood screws through the inside wall(s) of the damper assembly into the framing. If addition framing is to be added, place the framing over the damper assembly flanges and fasten in place.



**If using fasteners long enough to penetrate through the framing, use extreme caution to avoid drilling into hidden wiring, plumbing, or other building elements of concern!**

11. From below, install drywall screws through the ceiling and through the flanges of the damper assembly, and into any addition framing positioned above the flanges. Use care to avoid installing screws outside of the area that will be covered by the eggcrate inlet grille!
12. Hold the eggcrate grille in position on the ceiling, and install the included white screws through the holes in the flange of the grille, through the ceiling, and into the damper assembly flanges and/or framing above.



**Make sure that the eggcrate grille mounting screws penetrate into either the damper box flanges or framing above, and that the grille is securely fastened in place!**



# INSTALLATION: FAN & DUCT

## NOTES:

- The fan assembly must be soundly supported by attachment to structurally sound framing. Provide additional framing with minimum 2-by-4 lumber as needed for fan support.
- The fan assembly should be positioned with at least 24" of free space in front of the fan, for air to be freely blown into the attic by the fan.
- Position the fan with a slight upward angle and in a direction minimizing disturbance to attic insulation.
- The acoustical duct should be installed with a gentle bend of close to 90 degrees, from vertical to nearly horizontal, to minimize fan sound inside the living space. It must not be kinked or bent sharply, especially where leading into the fan.
- The acoustical duct must be installed with the air flow direction arrow (as marked on the duct) pointing downstream (towards the fan).

1. Lay the fan assembly on top of the ceiling joists, within a few feet of the damper assembly and underneath the area where the fan will be suspended in place.
2. Rotate and brace the fan assembly so that the electrical handy-box on the fan is in the 12-o'clock position (on the top of the fan). This is important to avoid twisting the duct, while having the fan's electrical handy-box within the 10- to 2-o'clock position once installed.
3. Adjust the flexible duct collar on the upstream end of the duct to be as loose as possible. Squeeze and position the flexible acoustic duct collar over the oval-shaped collar on the damper box, and attach using 3 of the screws provided, or other suitable screws. Note that twisting the duct will cause the fan to try to roll out of position. Seal the joint with approved duct tape, mastic, or other approved means.

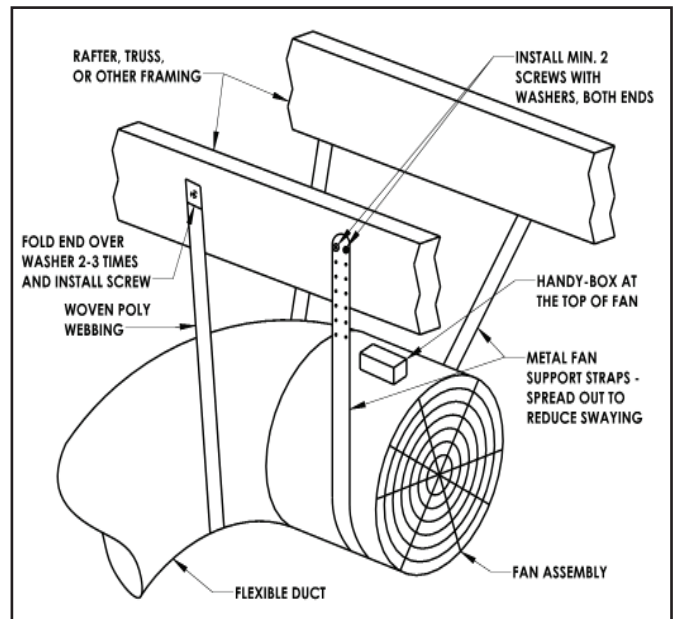

FIGURE 3: FAN & DUCT STRAPS DETAIL

4. Lift and support the fan assembly into position beneath the rafters, truss structure or other framing to be used to support the fan, with the electrical handy box at approximately the twelve-o-clock position. Attach both ends of the metal fan support strap to the framing using a minimum of two screws for each end of the strap. 1" drywall screws and large washers are supplied; other fasteners of appropriate strength may also be used.
5. Using the black woven poly strapping, support the acoustic flex duct by attaching the strapping to attic framing as shown. Fold each end over a large washer 2-3 times and fasten to the framing by driving the supplied 1" drywall screws or other appropriate fasteners through the washer and into the framing. The strapping may be cut to length with ordinary scissors if desired.
6. Replace the insulation around and over the damper assembly. Additional insulation may be added to further reduce heat transfer and fan noise from the attic to the living space.

## INSTALLATION: WIRING & CONTROLS



The Cascade PSC Series Whole-House Fan Systems require a 115 volt electrical power supply of minimum 15A ampacity and maximum 15 Amp circuit overcurrent protection.



All electrical components, whether included with the Cascade system or supplied by others, must be rated for the fan system's electrical load requirements; please refer to the Cascade Series specifications table for the electrical load requirements of the specific model to be installed.



All wiring and connections must be made according to this manual and all applicable electrical wiring codes and standards. All applicable electrical codes must be followed to the satisfaction of the local authority having jurisdiction.



A dedicated circuit is strongly recommended for this fan system.

1. In the living space, install the single gang plastic outlet box (provided) in the desired location.
2. Run a 15-amp 115 VAC power circuit to the plastic outlet box installed in the living space using romex 14-2 with ground wire (minimum). Refer to minimum ampacity and maximum overload protection requirements listed for this power run. Note: a dedicated circuit is recommended.

Note: Romex wire is defined as "wire Gauge - # of conductors" (ie: 14-2, 14-3). Always use Romex wire with Ground or equivalent wire to meet branch circuit ampacity.

3. For CA2-CA5 models WHF installation using power cord supplied with fan (reference Diagram: 1), pull 14-2 romex wire (minimum wire size) from the single gang box to separate single-gang outlet box installed in the attic less than 10 feet away from the fan assembly. The single-gang outlet box will require a NEMA5-15R receptacle and cover plate. The romex wire, single-gang outlet box, NEMA5-15R receptacle and cover plate are not supplied with product. Wall switch will allow fan to operate in single speed operation.

For CA2-CA5 models WHF installation hardwired (reference Diagram: 2), pull 14-3 romex wire (minimum wire size) from the single gang plastic box directly to the fan assembly electrical box and remove the fan power cord. Wall switch will allow fan to operate in two speed operation.

4. Make the wiring connections to the included switch as shown in Diagrams 1 and 2 for the fan model, control kit provided and desired method of wiring (power cord or hardwired).
5. Install the switch into the outlet box, and install the included wall plate.
6. In the attic, make the wiring connections as shown in the appropriate wiring diagram in the fan assembly handy-box or boxes.
7. Verify that grounding continuity is maintained properly to the fan assembly housing or housings.
8. Re-install the handy-box cover or covers.

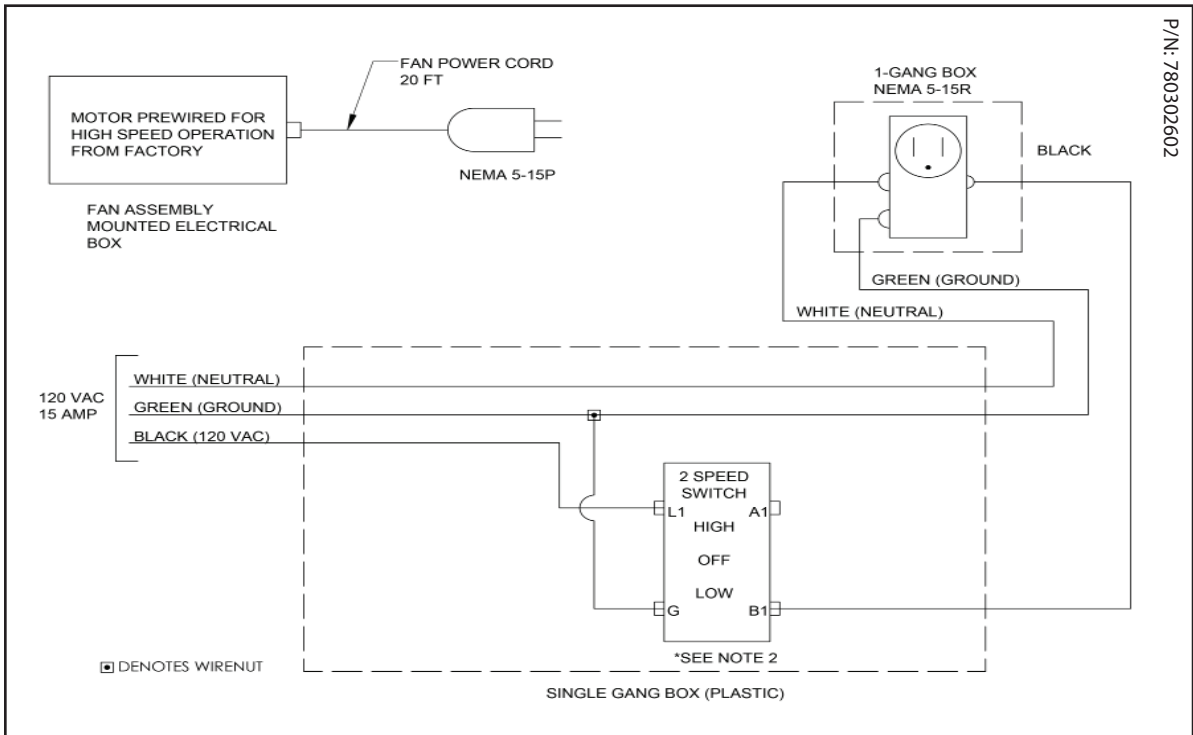

DIAGRAM 1: For CA2-CA5 Models with Single Speed & hardwired to Fan Assembly

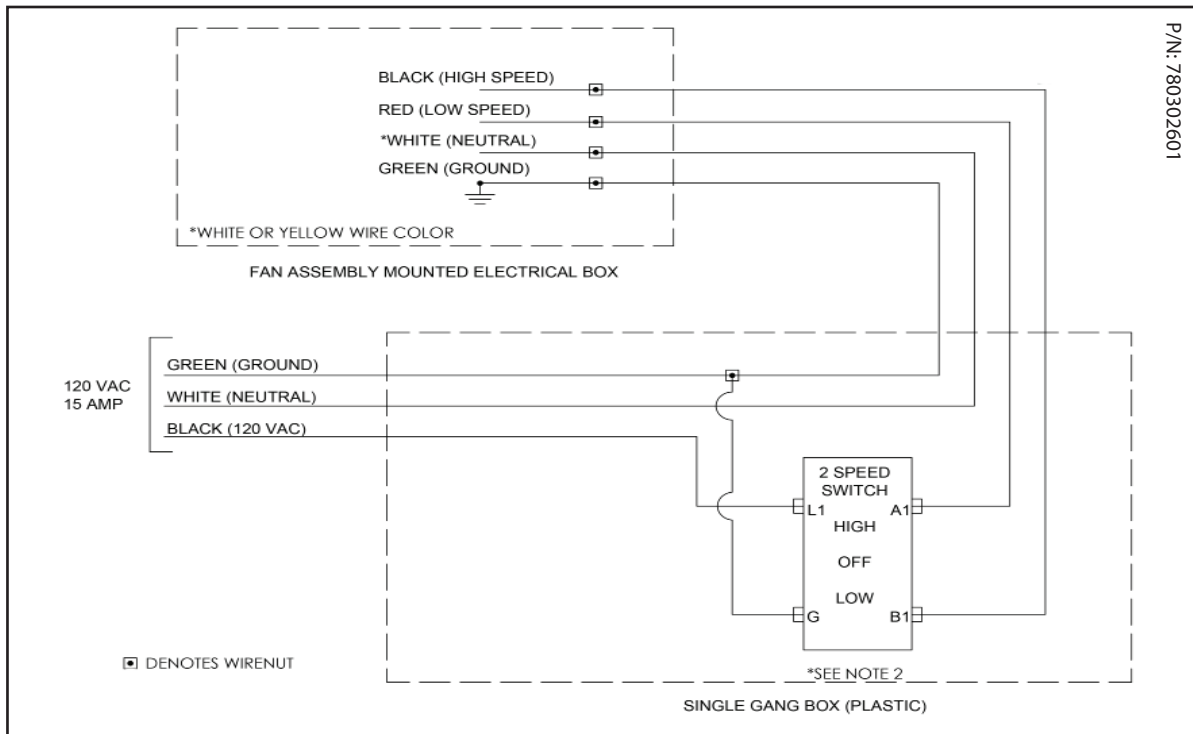

DIAGRAM 2: For CA2-CA5 Models with 2 Speed Wall Control



FIGURE 4 : STANDARD 2-SPEED SWITCH

## OPERATION

Before starting this fan for the first time, verify that:

- All wiring and connections have been made according to this manual and all applicable wiring codes and standards.
  - No tools or construction debris have been left in, on, or around the fan.
1. Switch the hi/off/low fan speed switch to off . Turn on power at breaker panel to whole house fan.
  2. Switch the fan speed switch to the desired fan speed.
  3. The fan will turn off if the speed switch is switched to off .

## IMPORTANT OPERATING TIPS

The following important tips for operating this fan have also been provided.

- **NEVER** operate this fan without also opening a window or door. Doing so can excessively depressurize the home.
- Only operate this fan when the outdoor air temperature is cooler than the indoor temperature.
- Make sure the home's air conditioner and furnace are OFF before turning on this fan. Running either of these together with this whole house fan wastes money because the fan will force expensively conditioned or heated air out of the home.
- We recommend running this fan through the night. The goal of using a whole house fan is to cool the entire home, not just the air inside it. Once heated, the home's structure and contents continue to radiate heat until reaching the temperature of the surrounding air. Running this fan through the night speeds up this cooling process and can then further "pre-cool" the home, reducing or eliminating the need to use air conditioning the next day.
- If the home has a basement, extra cooling can be achieved by drawing in air through the basement windows.
- This fan's cooling effect can be increased or concentrated in particular areas by adjusting the location of open windows. Visualize the path air will travel from the windows to your fan's opening. Generally, the longer the path, the more cooling.

## MAINTENANCE & TROUBLESHOOTING

Make sure the appropriate circuit breakers at the home's electrical panel are turned OFF before servicing this fan. There is no routine maintenance required for this fan other than making sure the fan assembly and gravity damper are kept clean of any possible buildup of debris.

Blocking this fan's exhaust can cause it to fail prematurely. Keep the area in front of the fan as unobstructed as possible: no object should be closer than 24" to the face of the fan.

This fan has been factory tested. If problems are encountered, please take a few moments to run through the following troubleshooting procedures before calling for assistance:

- If the fan does not turn on, check power to the unit and the wiring at both ends of the switch and the fan-mounted junction box.
- If the damper flaps do not open or close, visually inspect the damper for any debris obstructing their movement.

If the suggestions above do not work, contact your retailer for further assistance.

## SPECIFICATIONS\*

Speed Settings:	2
Gravity Damper Rough Opening Dimensions:	CA2, CA3: 14.5" W X 22.25" L CA4 & CA5: 14.5" W X 30.25" L
Grille Construction:	Aluminum Cube Core, Steel frame with White Powder Coat
Fan Diameter:	CA2, CA3: 18.75" CA4: 20.75" CA5: 22.75"
Duct Length:	7 ft.
Duct Diameter:	CA2: 16" CA3: 18" CA4 & CA5: 20"
Electrical:	115VAC, 60 Hz
Fan Motor: (HP/FLA)	CA2 & CA3: 1/3 HP / 4.9 CA4 & CA5: 1/2 HP / 6.5
Damper Door Insulation:	R5
Installation:	Installs easily on 24 inches or 16 inches O.C. framing
Attic Net Free Ventilation Area (Sq ft)	CA2: 3.86 CA3: 5.52 CA4: 7.28 CA5: 8.25
Open Window Ventilation Area (sq ft)	CA2: 7.73 CA3: 11.04 CA4: 14.56 CA5: 16.49

\*Due to our continual product improvement efforts, performance ratings and specifications are subject to change without notice.

\*\*Attic Net Free Ventilation and Open Window Ventilation Areas are listed as minimum requirements. Actual lower ventilation areas may reduce fans overall performance at high speeds.

(THIS PAGE LEFT INTENTIONALLY BLANK)

Item No.	Part Number	Description	Whole House Fan Model				
			CA2	CA3	CA4	CA5	
1	602601413	Fan Motor, 1/3 HP, 2 Speed	X	X			
2	602601412	Fan Motor, 1/2 HP, 2 Speed			X	X	
3	602601472	Motor Fastener Kit	X	X	X	X	
4	602601481	Fan Inlet Cone, 18 to 16	X				
5	602601482	Fan Inlet Cone, 22 to 20				X	
6	602601451	Flexible Duct Assembly, 16" Dia	X				
7	602601452	Flexible Duct Assembly, 18" Dia		X	X	X	
8	602601453	Flexible Duct Assembly, 20" Dia	X	X	X	X	
9	620074303	Cascade 2 Speed Control Kit	X	X	X	X	
10	602601407	2 Speed Fan Switch	X	X	X	X	
11	602601602	Damper Assembly, 14"x22", 16" Dia Inlet	X				
12	602601603	Damper Assembly, 14"x22", 18" Dia Inlet		X			
13	602601604	Damper Assembly, 14"x30", 20" Dia Inlet			X	X	
14	602601432	Capacitor, 10mF, 370V			X	X	
15	602601463	Capacitor, 7.5 mF, 370V for Century Motor	X	X			
15	602601465	Capacitor, 5.0 mF, 370V for US Motor/Nidec	X	X			
16	602601432	Fan Outlet Grille, 18" Dia	X	X			
17	602601434	Fan Outlet Grille, 20" Dia			X		
18	602601435	Fan Outlet Grille, 22" Dia				X	
19	602601471	Power Cord, 20 Ft Long	X	X	X	X	
20	602601422	Fan Blade, 18" Dia	X				
21	602601423	Fan Blade, 18" Dia		X			
22	602601424	Fan Blade, 20" Dia			X		
23	602601425	Fan Blade, 22" Dia				X	
24	602601141	Egg Crate Return Air Grille, 22x16	X	X			
25	602601142	Egg Crate Return Air Grille, 30x16			X	X	
26	602601475	Replacement Hardware Kit	X	X	X	X	
27	602601476	Replacement Nylon Strapping	X	X	X	X	
28	602601477	Strap, Fan Mounting Metal	X	X	X	X	
29	820100901	Box Wall Plastic Single Gang	X	X	X	X	

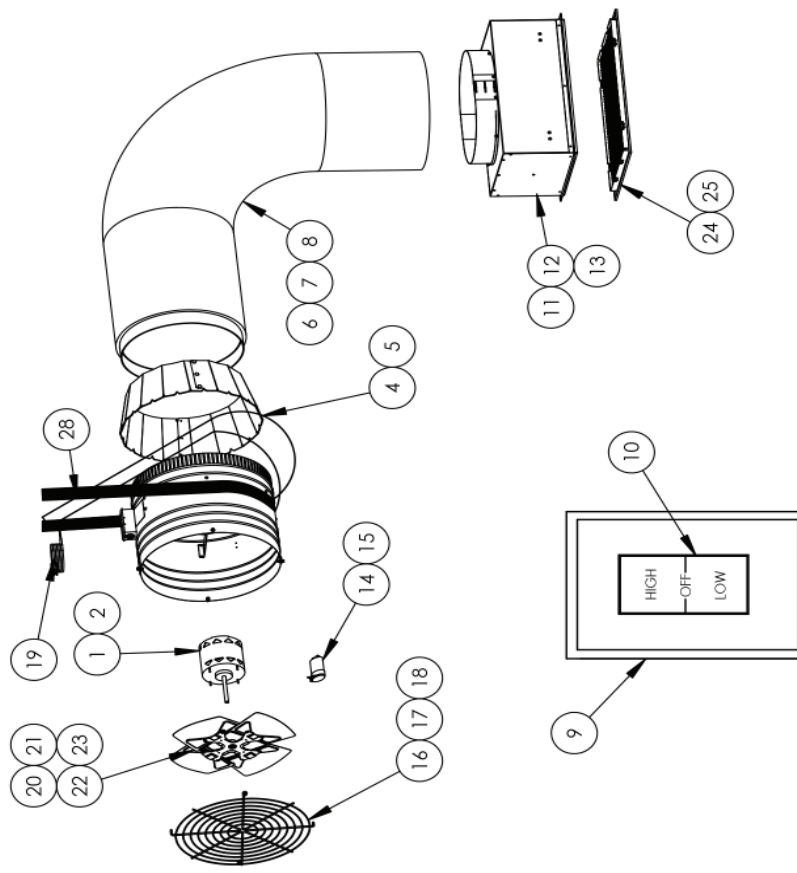

FIGURE 5: CASCADE REPLACEMENT PARTS

# air+health

## Whole House Fans



### Twelve (12) Year Limited Warranty

#### Provisions:

1. Contact Retailer for which original purchase has been made with warranty claim
2. Valid proof of purchase
3. Provide model number, serial number, and date code
4. Labor charges are not covered as part of the limited warranty

a. IN NO EVENT SHALL COMPANY BE LIABLE FOR ANY INDIRECT, SPECIAL, INCIDENTAL, CONSEQUENTIAL, OR SIMILAR DAMAGES (INCLUDING, BUT NOT LIMITED TO, LOST PROFITS OR REVENUE, INABILITY TO USE PRODUCT, OR OTHER ASSOCIATED EQUIPMENT, THE COST OF SUBSTITUTE EQUIPMENT, AND CLAIMS BY THIRD PARTIES) RESULTING FROM THE USE OF PRODUCT. Some states do not allow the exclusion or limitation of incidental or consequential damages, so the above limitation or exclusion may not apply to you.

b. THIS WARRANTY AND REMEDIES ARE EXCLUSIVE AND IN LIEU OF ALL OTHER WARRANTIES, REMEDIES AND CONDITIONS, WHETHER ORAL, WRITTEN, EXPRESS, STATUTORY, OR IMPLIED. TO THE EXTENT PERMITTED BY LAW, COMPANY DISCLAIMS ALL IMPLIED AND STATUTORY WARRANTIES, INCLUDING WARRANTIES OF MERCHANTABILITY AND FITNESS FOR A PARTICULAR PURPOSE.

c. Product that has been subjected to misuse, accident, shipping or other physical damage, improper installation or application, abnormal operation or handling, neglect, fire, water, or other liquid intrusion are not covered by the warranty.

