



# SOLANA™ ELECTRIC COUNTERFLOW FURNACE



The Solana™ Electric Counterflow Furnace is the practical choice for those areas where natural or propane gas installation is not convenient. Providing low-cost, floor-to-ceiling comfort and easy installation, this totally automatic, thermostat- controlled (*sold separately*) furnace is ideal for heating one or two rooms.

Freestanding or recessed, this furnace is at home almost anywhere and the decorator styling with a glossy white, red, gray or black will complement any decor.

## FEATURES

- Freestanding or recessed, the Solana Electric Counterflow Furnace is ideal for homes, apartments, offices, schools, cabins and many other applications
- Heating capacity of 31,400 BTU/hour
- Multi-room heating with optional outlet kits
- Glossy black, intergalactic (or space gray), red, or white-coated, high-heat resistant finish to complement any decor.
- Counterflow blower system circulates ceiling-to-floor warm air
- Occupies less than one square foot of floor space
- Automatic fan controls and safety devices

SOLANA™ ELECTRIC COUNTERFLOW FURNACE  
31,400 BTU/hr.



# SOLANA™ ELECTRIC COUNTERFLOW FURNACE

MODEL NO.	GLOSS COLOR	kW INPUT	HEATING OUTPUT BTU/hr.		OPERATING VOLTAGE MIN - MAX	DIMENSIONS INCHES			CFM 115V	CIRCUIT AMPS	DISCHARGE AIR TEMP AT 240V	SHIP WEIGHT LBS.
			@240V	@208V		WIDTH	DEPTH	HEIGHT				
3144030BC	Black	9.2	31,400	23,600	207 - 253	14.5	7.875	72.625	375	50	80 ° F RISE	60
3144030RC	Red	9.2	31,400	23,600	207 - 253	14.5	7.875	72.625	375	50	80 ° F RISE	60
3144030WG	White	9.2	31,400	23,600	207 - 253	14.5	7.875	72.625	375	50	80 ° F RISE	60
3144030IG	Gray	9.2	31,400	23,600	207 - 253	14.5	7.875	72.625	375	50	80 ° F RISE	60

## FEATURES

All wiring and controls are easily accessible from the front. Transformer, terminal block, relay and motor are factory pre-wired with thermostat wires pigtail outside. The total system plus individual elements are protected by safety limit switches.

### CONTEMPORARY FINISH

Glossy black, intergalactic (or space gray), red, or white-coated, high-heat resistant finish to complement any decor.

### BLOWER SYSTEM

Powerful, lint-free patented peripheral blower system and heavy-duty motor combine to deliver warm air smoothly and quietly on vibration-free mountings. Blower features a self-cleaning air scoop design. Motor, collid by a centrifugally swept air-stream, is equipped with self-aligning porous bearings. No filter is required.

### DIMENSIONS AND CLEARANCES

6" to an intersecting wall  
0" to finished floor

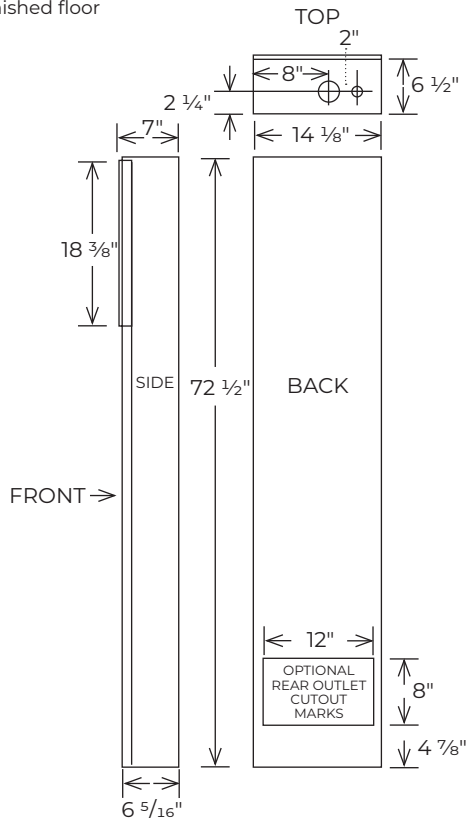

## ACCESSORIES

**THERMOSTAT SOLD SEPARATELY** part number 8967

### REAR-OUTLET REGISTER

Allows heated air to be delivered to a second room behind the furnace.

**MODEL 6501** Rear-Outlet Register with 10" boot Shipping weight 7 lbs.

### EASY INSTALLATION

This Solana™ Electric Counterflow Wall Furnace requires less than one square foot of floor space and provides warm air circulation for maximum comfort.

The 9.2kW input, 31,400 BTU/hr. output model delivers heat into one or two rooms via a large quiet blower. This model may be recessed into the stud space or surface mounted. With a cabinet depth of just under eight inches, recessed installation provides a projection of only three inches into the living space. A freestanding application solves the problem in otherwise hard-to-heat areas. Totally automatic fan controls and safety devices are factory supplied.

### TYPICAL INSTALLATIONS

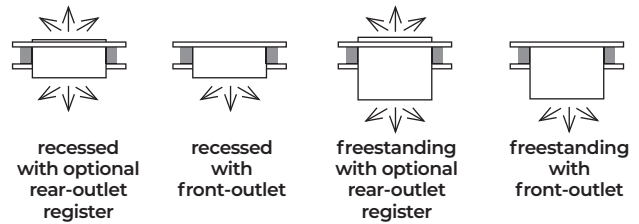

### IMPORTANT

**ANY WARRANTY CONSIDERATIONS ARE CONTINGENT ON INSTALLATION BY A QUALIFIED INSTALLER (CONTRACTOR). SELF-INSTALLATION IS PROHIBITED AND WILL INVALIDATE YOUR WARRANTY.**

- Read owner's manual before using/installing.
- Photographs are representative only.
- Check local codes and ordinances for permitted uses.
- Consult installation manual for clearances prior to installation.
- We reserve the right to amend product specifications without notice.
- Installation and servicing recommended by a qualified service person.
- Please read the warranty for any limitations of disclaimers. Combustion chamber carries a 10-year limited warranty. All other parts carry a one-year limited warranty.



**WARNING:** This product can expose you to chemicals including epichlorohydrin which is known to the State of California to cause cancer and birth defects and/or other reproductive harm. For more information go to [www.p65warnings.ca.gov](http://www.p65warnings.ca.gov)