

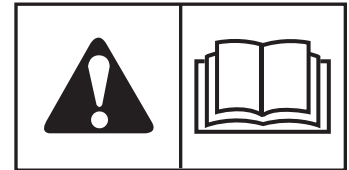

Operator's Manual



ZT4000 Series

Mfg. No.
5900707
5900765
5900960

Description

ZT4000B2444, Zero-Turn Rider w/ 44" Mower
ZT4000B2648, Zero-Turn Rider w/ 48" Mower
ZT4000B2748, Zero-Turn Rider w/ 48" Mower

Reproduction

General Information

Thank you for purchasing this quality-built Simplicity product. We're pleased that you've placed your confidence in the Simplicity brand. When operated and maintained according to the instructions in this manual, your Simplicity product will provide many years of dependable service.

This manual contains safety information to make you aware of the hazards and risks associated with this machine and how to avoid them. This machine is designed and intended to be used and maintained according to the manual for finish cutting of established lawns and is not intended for any other purpose. It is important that you read and understand these instructions thoroughly before attempting to start or operate this equipment. **Save these original instructions for future reference.**

PRODUCT REFERENCE DATA	
Unit Model Number	Unit SERIAL Number
Mower Deck Model Number	Mower Deck SERIAL Number
Dealer Name	Date Purchased
ENGINE REFERENCE DATA	
Engine Make	Engine Model
Engine Type/Spec.	Engine Code/Serial Number

See **Features & Controls** for the location of Identification Numbers

Technical Manuals

The Illustrated Parts List for this machine can be downloaded from www.simplicitymfg.com. Please provide model and serial number when ordering replacement parts.

Briggs & Stratton Power Products Group, LLC.
Copyright © 2012 Briggs & Stratton Corporation
Milwaukee, WI, USA. All rights reserved.

SIMPLICITY is a trademark of Briggs & Stratton Corporation, Milwaukee, WI, USA.

WARNING

The engine exhaust from this product contains chemicals known to the State of California to cause cancer, birth defects, or other reproductive harm.

WARNING

Battery posts, terminals, and related accessories contain lead and lead compounds – chemicals known to the State of California to cause cancer and reproductive harm. Wash hands after handling.

Table of Contents

Operator Safety	4
Safety Rules & Information	4
Safety Decals	13
Safety Icons & Interlock System	14
Features & Controls	15
Identification Numbers	15
Control Functions	16
Operation.....	18
General Operating Safety	18
Checks Before Starting	18
Check Tire Pressures	19
Seat Adjustment.....	19
Pushing the Rider by Hand.....	19
Mowing Height Adjustment	20
Foot Pedal Adjustment	20
Starting the Engine	21
Stopping the Rider	21
Zero Turn Driving Practice.....	22
Storage	24
Mowing.....	24
Mowing Recommendations.....	24
Mowing Methods.....	25
Attaching a Trailer.....	26
Regular Maintenance	27
Maintenance Schedule	27
Checking/Adding Fuel.....	28
Fuel Filter	28
Change Oil & Filter	28
Inspect Muffler and Spark Arrester.....	28
Battery Charging.....	28
Check Hydraulic Oil Level.....	29
Change Hydraulic Oil Filter	29
Battery Maintenance.....	29
Lubrication	30
Servicing the Mower Blades	31
Ground Speed Control Lever Adjustment.....	33
Speed Balancing Adjustment.....	33
Neutral Adjustment	34
Return-to-Neutral Adjustment	34
Parking Brake Adjustment	35
Hydraulic Pump Drive Belt Replacement	35
Suspension Adjustment	36
Deck Lift Rod Timing Adjustment	37
Deck Leveling Adjustment	37
Mower Belt Replacement.....	38
Troubleshooting	40
Troubleshooting the Tractor.....	40
Troubleshooting the Mower	41
Troubleshooting Common Cutting Problems.....	42
Specifications	43
Slope Identification Guide	44

NOTE: In this manual, “left” and “right” are referred to as seen from the operating position.

Operator Safety



Operating Safety

Congratulations on purchasing a superior-quality piece of lawn and garden equipment. Our products are designed and manufactured to meet or exceed all industry standards for safety.

Do not operate this machine unless you have been trained. Reading and understanding this operator's manual is a way to train yourself.

Power equipment is only as safe as the operator. If it is misused, or not properly maintained, it can be dangerous! Remember, you are responsible for your safety and that of those around you.

Use common sense, and think through what you are doing. If you are not sure that the task you are about to perform can be safely done with the equipment you have chosen, ask a professional: contact your local authorized dealer.

Read the Manual

The operator's manual contains important safety information you need to be aware of BEFORE you operate your unit as well as DURING operation.

Safe operating techniques, an explanation of the product's features and controls, and maintenance information is included to help you get the most out of your equipment investment.

Be sure to completely read the Safety Rules and Information found on the following pages. Also completely read the Operation section.

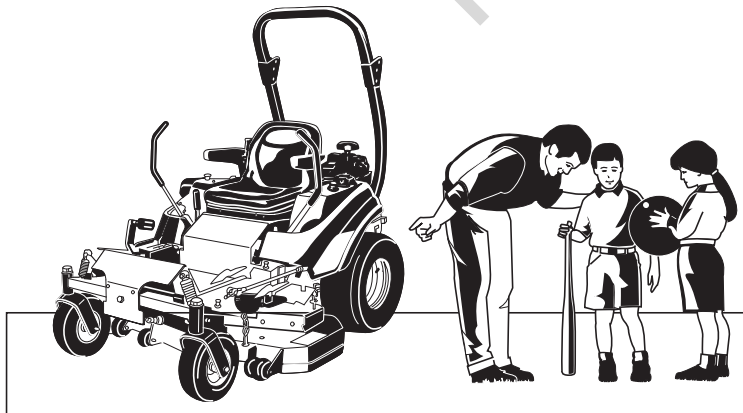
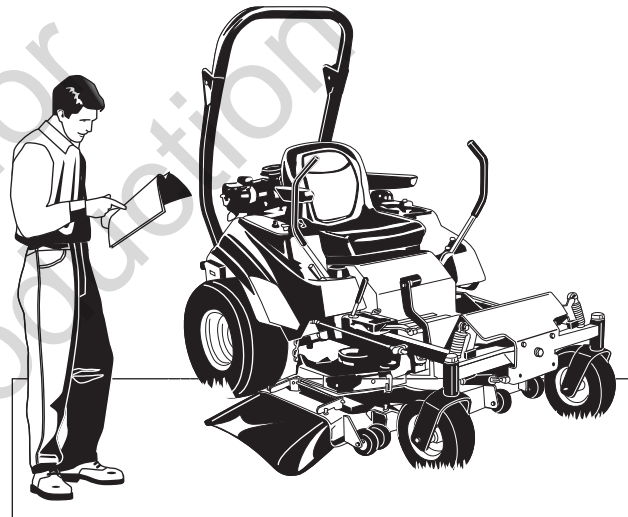

Children

Tragic accidents can occur with children. Do not allow them anywhere near the area of operation. Children are often attracted to the unit and mowing activity. Never assume that children will remain where you last saw them. If there is a risk that children may enter the area where you are mowing, have another responsible adult watch them.

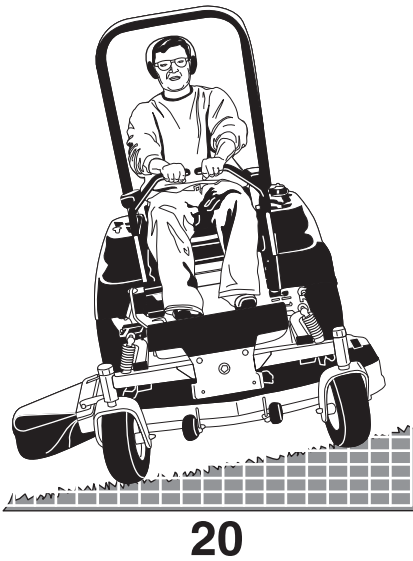

5.4

20

Slope Operation

Operation on slopes can be dangerous. Using the unit on a slope that is too steep where you do not have adequate wheel traction (and control) can cause sliding, loss of steering, control, and possible rollover. You should not operate on a slope greater than a 5.4 foot rise over a 20 foot length (15 degrees).

Always mow across slopes, not up and down (to maintain traction on the wheels) and avoid sudden turns or rapid speed changes. Reduce speed and use extreme caution on ALL slopes.

Also, note that the surface condition you are on can greatly impact your ability to safely operate this machine. Operating on wet or slippery slopes can cause sliding and loss of steering and control. Do not operate on slopes that are slippery, wet, or have soft soil conditions.

If you feel unsure about operating the unit on a slope, don't do it. It's not worth the risk.

Thrown Objects

This unit has spinning mower blades. These blades can pick up and throw debris that could seriously injure a bystander. Be sure to clean up the area to be mowed and remove objects that could be thrown by the blade BEFORE you start mowing.

Do not operate this unit without the entire grass catcher or discharge guard (deflector) in place.

Also, do not allow anyone in the area while the unit is running! If someone does enter the area, shut the unit off immediately until they leave

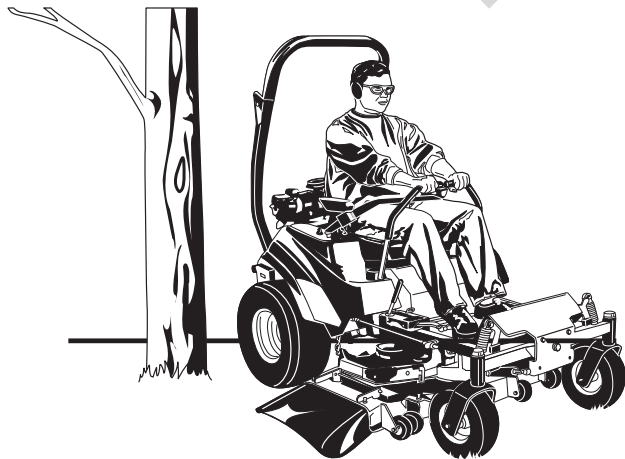
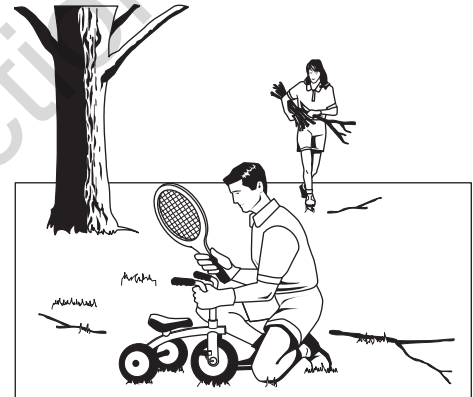

Moving Parts

This equipment has many moving parts that can injure you or someone else. However, if you stay in the operator zone (stay seated in the seat), and follow the safety rules in this operator's manual, the unit is safe to operate.

The mower deck has spinning mower blades that can amputate hands and feet. Do not allow anyone near the unit while it is running! Keep safety devices (guards, shields, and switches) in place and working.

To help you, the operator, use this equipment safely, it is equipped with an operator-present safety system. Do NOT attempt to alter or bypass the system. See your dealer immediately if the system does not pass all the safety interlock system tests found in this manual.



Roll Bar Use

Keep the roll bar in position and fasten the seat belt. Do not jump off if the mower tips (it is safer to be secured by the seat belt.)

NEVER remove the roll bar.

Retaining Walls, Drop-offs, and Water

Retaining walls and drop-offs around steps and water are a common hazard. Give yourself a minimum of two mower widths of clearance around these hazards and hand-trim with a walk behind mower or string trimmer. Wheels dropping over retaining walls, edges, ditches, embankments, or into water can cause rollovers, which may result in serious injury, death, or drowning.

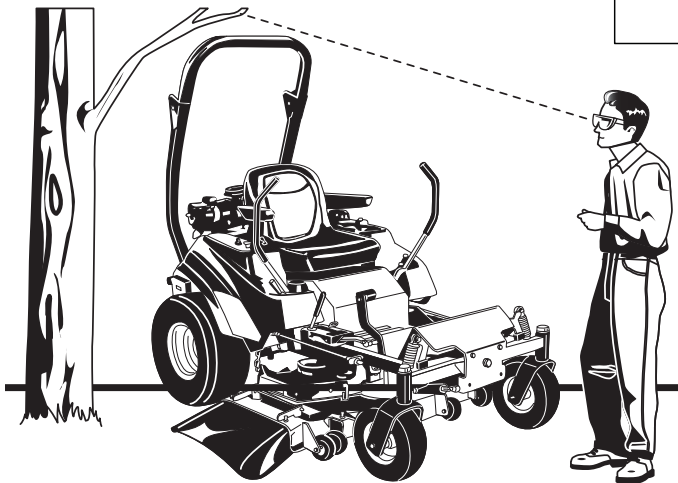
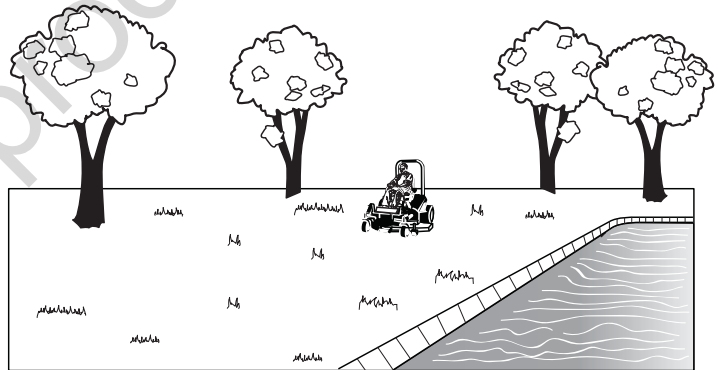
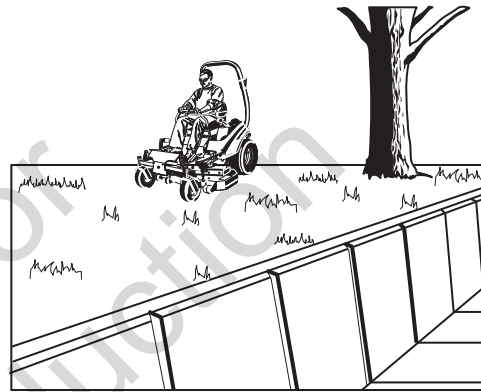

Overhead Obstacles

Check for overhead clearances before driving under any objects. Do not allow the roll bar to contact low overhanging obstacles such as tree branches and guide wires.

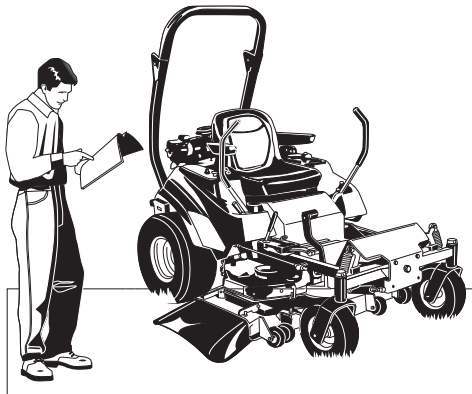
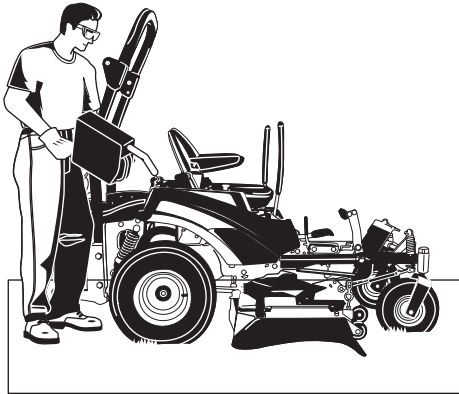

Fuel and Maintenance

Always disengage all drives, shutoff the engine, and remove the key before doing any cleaning, refueling, or servicing.

Gasoline and its vapors are extremely flammable. Do not smoke while operating or refueling. Do not add fuel while engine is hot or running. Allow engine to cool for at least 3 minutes prior to adding fuel.

Do not add fuel indoors, in an enclosed trailer, garage, or any other enclosed area that is not well ventilated. Gasoline spills should be cleaned up promptly and before operation begins.

Gasoline should be stored only in sealed containers approved for fuel.

Proper maintenance is critical to the safety and performance of your unit. Keep the unit free of grass, leaves, and excess oil. Be sure to perform the maintenance procedures listed in this manual, especially periodically testing the safety system.

Enclosed Areas

Only operate this unit outdoors and away from unventilated areas such as inside garages or enclosed trailers. The engine emits poisonous carbon monoxide gas and prolonged exposure in an enclosed area can result in serious injury or death.

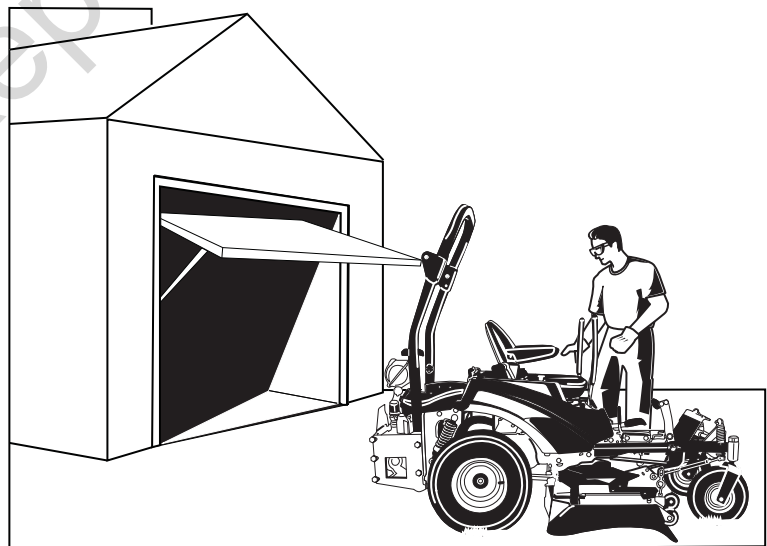



Read these safety rules and follow them closely. Failure to obey these rules could result in loss of control of unit, severe personal injury or death to you, or bystanders, or damage to property or equipment. **This mowing deck is capable of amputating hands and feet and throwing objects.** The triangle  in text signifies important cautions or warnings which must be followed.

General Operation

1. Read, understand, and follow all instructions in the manual and on the unit before starting.
2. Do not put hands or feet near rotating parts or under the machine. Keep clear of the discharge opening at all times.
3. Only allow responsible adults, who are familiar with the instructions, to operate the unit (local regulations can restrict operator age).
4. Clear the area of objects such as rocks, toys, wire, etc., which could be picked up and thrown by the blade(s).
5. Be sure the area is clear of other people before mowing. Stop the unit if anyone enters the area.
6. Never carry passengers.
7. Do not mow in reverse unless absolutely necessary. Always look down and behind before and while travelling in reverse.
8. Never direct discharge material toward anyone. Avoid discharging material against a wall or obstruction. Material may ricochet back toward the operator. Stop the blade(s) when crossing gravel surfaces.
9. Do not operate the machine without the entire grass catcher, discharge guard (deflector), or other safety devices in place and operational.
10. Slow down before turning.
11. Never leave a running unit unattended. Always disengage the blades (PTO), set parking brake, stop engine, and remove keys before dismounting.
12. Disengage blades (PTO) when not mowing. Shut off engine and wait for all parts to come to a complete stop before cleaning the machine, removing the grass catcher, or unclogging the discharge guard.
13. Operate the machine only in daylight or good artificial light.
14. Do not operate the unit while under the influence of alcohol or drugs.
15. Watch for traffic when operating near or crossing roadways.
16. Use extra care when loading or unloading the unit into a trailer or truck.
17. Always wear eye protection when operating this unit.
18. Data indicates that operators, age 60 years and above, are involved in a large percentage of power equipment-related injuries. These operators should evaluate their ability to operate the equipment safely enough to protect themselves and others from injury.
19. Follow the manufacturer's recommendations for wheel weights or counterweights.
20. Keep in mind the operator is responsible for accidents occurring to other people or property.
21. All drivers should seek and obtain professional and practical instruction.
22. Always wear substantial footwear and trousers. Never operate when barefoot or wearing sandals.
23. Before using, always visually check that the blades and blade hardware are present, intact, and secure. Replace worn or damaged parts.
24. Disengage attachments before: refueling, removing an attachment, making adjustments (unless the adjustment can be made from the operator's position).
25. When the machine is parked, stored, or left unattended, lower the cutting means unless a positive mechanical lock is used.
26. Before leaving the operator's position for any reason, engage the parking brake (if equipped), disengage the blades (PTO), stop the engine, and remove the key.
27. To reduce fire hazard, keep the unit free of grass, leaves, & excess oil. Do not stop or park over dry leaves, grass, or combustible materials.
28. OSHA regulations may require the use of hearing protection when exposed to sound levels greater than 85 dBA for an 8 hour time period.

WARNING

It is a violation of California Public Resource Code, Section 4442, to use or operate the engine on any forest-covered, brush-covered, or grass-covered land unless the exhaust system is equipped with a spark arrester, as defined in Section 4442, maintained in effective working order. Other states or federal jurisdictions may have similar laws. Contact an Authorized Service Dealer to obtain a spark arrester designed for the exhaust system installed on this engine.

WARNING



Extended exposure to excessively high sound levels can result in hearing loss.

- This machine produces sound levels in excess of 85 dBA at the operator's ear and can cause hearing loss through extended periods of exposure.
- Wear hearing protection when operating this machine.

Transporting and Storage

1. When transporting the unit on an open trailer, make sure it is facing forward, in the direction of travel. If the unit is facing backwards, wind lift could damage the unit.
2. Always observe safe refueling and fuel handling practices when refueling the unit after transportation or storage.
3. Never store the unit (with fuel) in an enclosed poorly ventilated structure. Fuel vapors can travel to an ignition source (such as a furnace, water heater, etc.) and cause an explosion. Fuel vapor is also toxic to humans and animals.
4. Always follow the engine manual instructions for storage preparations before storing the unit for both short and long term periods.
5. Always follow the engine manual instructions for proper start-up procedures when returning the unit to service.
6. Never store the unit or fuel container inside where there is an open flame or pilot light, such as in a water heater. Allow unit to cool before storing.

Slope Operation

Slopes are a major factor related to loss-of-control and tip-over accidents, which can result in severe injury or death. Operation on all slopes requires extra caution. If you cannot back up the slope or if you feel uneasy on it, do not operate on it.

Control of a walk-behind or ride-on machine sliding on a slope will not be regained by the application of the brake. The main reasons for loss of control are: insufficient tire grip on the ground, speed too fast, inadequate braking, the type of machine is unsuitable for its task, lack of awareness of the ground conditions, incorrect hitching and load distribution.

1. Mow across slopes, not up and down.
2. Watch for holes, ruts, or bumps. Uneven terrain could overturn the unit. Tall grass can hide obstacles.
3. Choose a slow speed so that you will not have to stop or change speeds while on the slope.
4. Do not mow on wet grass. Tires may lose traction.
5. Avoid starting, stopping, or turning on a slope. If tires lose traction (i.e. machine stops forward motion on a slope), disengage the blade(s) (PTO) and drive slow off the slope.
6. Keep all movement on slopes slow and gradual. Do not make sudden changes in speed or direction, which could cause the machine to rollover.
7. Use extra care while operating machines with grass catchers or other attachments; they can affect the stability of the unit. Do not use on steep slopes.
8. Do not try to stabilize the machine by putting your foot on the ground (ride-on units).
9. Do not mow near drop-offs, ditches, or embankments. The mower could suddenly turn over if a wheel is over the edge of a cliff or ditch, or if an edge caves in.
10. Do not use grass catchers on steep slopes.
11. Do not mow slopes if you cannot back up them.
12. See your authorized dealer/retailer for recommendations of wheel weights or counterweights to improve stability.
13. Remove obstacles such as rocks, tree limbs, etc.
14. Use slow speed. Tires may lose traction on slopes even though the brakes are functioning properly.
15. Do not turn on slopes unless necessary, and then, turn slowly and gradually uphill, if possible. Never mow down slopes.

Towed Equipment (Ride-On Units)

1. Tow only with a machine that has a hitch designed for towing. Do not attach towed equipment except at the hitch point.
2. Follow the manufacturer's recommendations for weight limit for towed equipment and towing on slopes. See attaching a trailer under OPERATION.
3. Never allow children or others in or on towed equipment.
4. On slopes, the weight of the towed equipment may cause loss of traction and loss of control.
5. Travel slowly and allow extra distance to stop.
6. Do not shift to neutral and coast down hill.

Children

Tragic accidents can occur if the operator is not alert to the presence of children. Children are often attracted to the unit and the mowing activity. Never assume that children will remain where you last saw them.

1. Keep children out of the mowing area and under the watchful care of another responsible adult.
2. Be alert and turn unit off if children enter the area.
3. Before and during reverse operation, look behind and down for small children.
4. Never carry children, even with the blade(s) off. They may fall off and be seriously injured or interfere with safe unit operation. Children who have been given rides in the past may suddenly appear in the mowing area for another ride and be run over or backed over by the machine.
5. Never allow children to operate the unit.
6. Use extra care when approaching blind corners, shrubs, trees, or other objects that may obscure vision.

Emissions

1. Engine exhaust from this product contains chemicals known, in certain quantities, to cause cancer, birth defects, or other reproductive harm.
2. Look for the relevant Emissions Durability Period and Air Index information on the engine emissions label.

Ignition System

1. This spark ignition system complies with Canadian ICES-002.

⚠ WARNING	
	<p>Operating on steep slopes can be dangerous.</p>
<ul style="list-style-type: none"> • Never operate on slopes greater than 15°. • Select slow ground speed before driving onto a slope. Use extra caution when operating on slopes with a rear-mounted grass catcher. • Mow across the face of slopes, not up and down, use caution when changing directions and DO NOT START OR STOP ON A SLOPE. 	

Service and Maintenance

Safe Handling of Gasoline

1. Extinguish all cigarettes, cigars, pipes, and other sources of ignition.
2. Use only approved gasoline containers.
3. Never remove the gas cap or add fuel with the engine running. Allow the engine to cool before refueling.
4. Never fuel the machine indoors.
5. Never store the machine or fuel container where there is an open flame, spark, or pilot light such as near a water heater or other appliance.
6. Never fill containers inside a vehicle or on a truck bed with a plastic bed liner. Always place containers on the ground away from your vehicle before filling.
7. Remove gas-powered equipment from the truck or trailer and refuel it on the ground. If this is not possible, then refuel such equipment on a trailer with a portable container, rather than from a gasoline dispenser nozzle.
8. Keep nozzle in contact with the rim of the fuel tank or container opening at all times until fueling is complete. Do not use a nozzle lock-open device.
9. If fuel is spilled on clothing, change clothing immediately.
10. Never over-fill the fuel tank. Replace gas cap and tighten securely.
11. Use extra care in handling gasoline and other fuels. They are flammable and vapors are explosive.
12. If fuel is spilled, do not attempt to start the engine but move the machine away from the area of spillage and avoid creating any source of ignition until fuel vapors have dissipated.
13. Replace all fuel tank caps and fuel container caps securely.

Service & Maintenance

1. Never run the unit in an enclosed area where carbon monoxide fumes may collect.
2. Keep nuts and bolts, especially blade attachment bolts, tight and keep equipment in good condition.
3. Never tamper with safety devices. Check their proper operation regularly and make necessary repairs if they are not functioning properly.
4. Keep unit free of grass, leaves, or other debris build-up. Clean up oil or fuel spillage. and remove any fuel-soaked debris. Allow machine to cool before storage.
5. If you strike an object, stop and inspect the machine. Repair, if necessary, before restarting.
6. Never make adjustments or repairs with the engine running.
7. Check grass catcher components and the discharge guard frequently and replace with manufacturer's recommended parts, when necessary.
8. Mower blades are sharp. Wrap the blade or wear gloves, and use extra caution when servicing them.
9. Check brake operation frequently. Adjust and service as required.
10. Maintain or replace safety and instructions labels, as necessary.
11. Do not remove the fuel filter when the engine is hot as spilled gasoline may ignite. Do not spread

- fuel line clamps further than necessary. Ensure clamps grip hoses firmly over the filter after installation.
12. Do not use gasoline containing METHANOL, gasohol containing more than 10% ETHANOL, gasoline additives, or white gas because engine/fuel system damage could result.
13. If the fuel tank must be drained, it should be drained outdoors.
14. Replace faulty silencers/mufflers.
15. Maintain or replace safety and instruction labels as necessary.
16. Use only factory authorized replacement parts when making repairs.
17. Always comply with factory specifications on all settings and adjustments.
18. Only authorized service locations should be utilized for major service and repair requirements.
19. Never attempt to make major repairs on this unit unless you have been properly trained. Improper service procedures can result in hazardous operation, equipment damage and voiding of manufacturer's warranty.
20. On multiple blade mowers, take care as rotating one blade can cause other blades to rotate.
21. Do not change engine governor settings or over-speed the engine. Operating the engine at excessive speed can increase the hazard of personal injury.
22. Disengage drive attachments, stop the engine, remove the key, and disconnect the spark plug wire(s) before: clearing attachment blockages and chutes, performing service work, striking an object, or if the unit vibrates abnormally. After striking an object, inspect the machine for damage and make repairs before restarting and operating the equipment.
23. Never place hands near the moving parts, such as a hydro pump cooling fan, when the tractor is running. (Hydro pump cooling fans are typically located on top of the transaxle).
24. Units with hydraulic pumps, hoses, or motors: **WARNING:** Hydraulic fluid escaping under pressure may have sufficient force to penetrate skin and cause serious injury. If foreign fluid is injected into the skin it must be surgically removed within a few hours by a doctor familiar with this form of injury or gangrene may result. Keep body and hands away from pin holes or nozzles that eject hydraulic fluid under high pressure. Use paper or cardboard, and not hands, to search for leaks. Make sure all hydraulic fluid connections are tight and all hydraulic hoses and lines are in good condition before applying pressure to the system. If leaks occur, have the unit serviced immediately by your authorized dealer.
25. **WARNING:** Stored energy device. Improper release of springs can result in serious personal injury. Springs should be removed by an authorized technician.
26. Models equipped with an engine radiator: **WARNING:** Stored energy device. To prevent serious bodily injury from hot coolant or steam blow-out, never attempt to remove the radiator cap while the engine is running. Stop the engine and wait until it is cool. Even then, use extreme care when removing the cap

Roll Bar Instructions

For models equipped with factory-installed Roll Over Protection System (ROPS).

WARNING

In order to avoid serious injury or death from roll over, it is important to follow the warnings listed below.

Operational Warnings

- Always use the seat belt when the roll bar is in the raised position.
- Never use the seat belt when the roll bar is in the down position.
- Remember there is no roll over protection when the roll bar is in the down position so it is very important to always keep the roll bar in the raised position whenever possible.
- Lower the roll bar to the down position only when it is absolutely necessary.
- Check for overhead clearances before driving under any objects. Do not allow roll bar to contact low overhanging obstacles such as tree branches and guide wires.
- Never remove the roll bar from the vehicle.
- Do not exceed the machine weight rating of the roll bar.
- Read and follow all of the instructions shown below regarding the inspection and maintenance of the roll bar structure and the seat belt.

Inspection of the Roll Bar Protective Structure

WARNING

Failure to properly inspect and maintain the Roll Bar protective structure can cause serious injury or death.

A ROLL BAR, like any other safety device, needs to be periodically inspected to verify that the integrity of the device has not been compromised through normal machine use, misuse, age degradation, modifications, or a roll over.

To maintain operator roll over protection and roll bar effectiveness:

- If a ROLL BAR becomes damaged for any reason, such as a collision, roll over or impact, the ROLL BAR must be replaced. Small undetectable cracks can reduce the effectiveness of the ROLL BAR. Never weld, straighten, or repair the ROLL BAR.
- Never alter the ROLL BAR by welding anything to it or by drilling additional holes.

- **Before First Time Use** - Inspect the ROLL BAR structure and mounting hardware for:

- 1) Check to make sure the machine GVW (Gross Vehicle Weight), including attachments, restrained payload, fuel and operator, is not in excess of the maximum weight specified on the ROLL BAR label.
- 2) Make sure there isn't any missing, damaged, or loose mounting hardware.
- 3) Make sure the ROLL BAR has been correctly and completely installed.

- **Every 100 Hours** - Inspect the ROLL BAR structure and mounting hardware for:

- 1) Any cracks in the structure (structural members and/or welds).
- 2) Significant corrosion on any part of the ROLL BAR structure or hardware.
- 3) Missing, damaged, or loose mounting hardware.
- 4) Mounting hardware that is of a grade lesser than specified.
- 5) Machine GVW (Gross Vehicle Weight), including attachments, restrained payload, fuel and operator, in excess of the maximum weight specified on the ROLL BAR label.
- 6) Any modifications that have been made, such as unauthorized welds and holes.
- 7) Any permanent deformation or twisting of the ROLL BAR structure.
- 8) That the ROLL BAR label is still in place and is readable.
- 9) That the ROLL BAR on-product warning labels are still on the ROLL BAR and are readable.

- If there is any doubt as to the condition of the ROLL BAR, remove the machine from service and contact your dealer for assistance.

Inspection and Maintenance of the Roll Bar Seat Belt

⚠ WARNING

Failure to properly inspect and maintain the seat belt can cause serious injury or death.

- The seat belt like the ROLL BAR, needs to be periodically inspected to verify that the integrity has not been compromised through normal machine use, misuse, age degradation, modifications, or a roll over. If the seat belt does not pass all of the following tests, it should be replaced.
- **Before Each Use** – Conduct the following inspections/maintenance of the seat belt and retraction mechanism:
 - 1) Check for dirt or debris in the retraction mechanism. If dirt or debris is found, it should be removed.
 - 2) Check to make sure the retraction mechanism retracts easily and completely.
 - 3) Check for damage to any part of the seat belt such as nicks, cuts, loose stitching, or fraying.
 - 4) Check that the buckle and latch operate properly and that the latch plate is not excessively worn, deformed, or the buckle is damaged or cracked. The seat belt should latch and release easily.

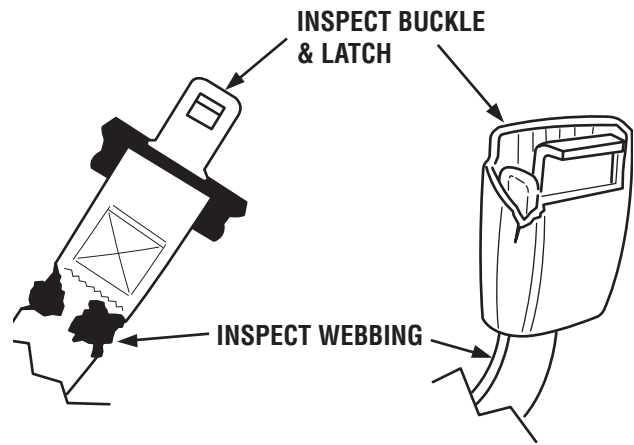

Safety Decals

This unit has been designed and manufactured to provide you with the safety and reliability you would expect from an industry leader in outdoor power equipment manufacturing.

Although reading this manual and the safety instructions it contains will provide you with the necessary basic knowledge to operate this equipment safely and effectively, we have placed several safety labels on the unit to remind you of this important information while you are operating your unit.

All DANGER, WARNING, CAUTION and instructional messages on your rider and mower should be carefully read and obeyed. Personal bodily injury can result when these instructions are not followed. The information is for your safety and it is important! The safety decals below are on your rider and mower.

If any of these decals are lost or damaged, replace them at once. See your local dealer for replacements.

These labels are easily applied and will act as a constant visual reminder to you, and others who may use the equipment, to follow the safety instructions necessary for safe, effective operation.

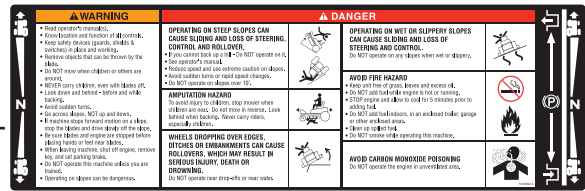

1

2

3

4

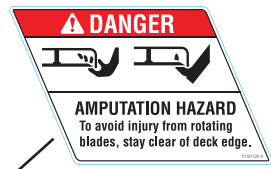

(2 per unit. Located behind Roll Bar on each side of the unit.)



WARNING
AVOID SERIOUS INJURY OR DEATH FROM ROLL OVER:
 Keep roll bar in the raised position and use seat belt.
THERE IS NO ROLL OVER PROTECTION WHEN THE ROLL BAR IS DOWN
 Lower the roll bar only when necessary and NEVER remove it.
 Do NOT use seat belt when the roll bar is down.
 Raise the roll bar as soon as clearance permits.
 Do NOT jump off if mower tips.
 Read and follow all operating instructions and warnings in the operator's manual.

ADVERTENCIA
EVITE LESIONES GRAVES O LA MUERTE POR VOLCADURAS:
 Mantenga la barra antivuelco en la posición elevada y utilice el cinturón de seguridad.
NO TENDRÁ PROTECCIÓN CUANDO LA BARRA ANTI-VUELCO ESTÁ ABAJO
 Baje la barra antivuelco solamente cuando sea necesario y NO la quite NUNCA.
 NO utilice el cinturón de seguridad cuando la barra antivuelco está abajo.
 Suba la barra antivuelco tan pronto como lo permita el espacio.
 NO salte de la podadora cuando ésta se vuelque.
 Lea el manual del operador y siga las instrucciones de operación y las advertencias ahí incluidas.

CAUTION
ROLL OVER PROTECTIVE STRUCTURE
 To maintain operator protection and roll bar certification:
 Replace a damaged roll bar; do NOT attempt to repair or modify.
 Any alteration of the roll bar must be approved by the manufacturer.
DO NOT exceed the machine weight rating of the roll bar.

PRECAUCIÓN
ESTRUCTURA PROTECTORA CONTRA VOLCADURAS
 Para mantener protegido al operador y la certificación de la barra antivuelco:
 Reemplace la barra antivuelco dañada; NO intente repararla ni modificarla.
 Cualquier cambio a la barra antivuelco debe ser aprobado por el fabricante.
NO exceda la clasificación de peso de la máquina que especifica la barra antivuelco.

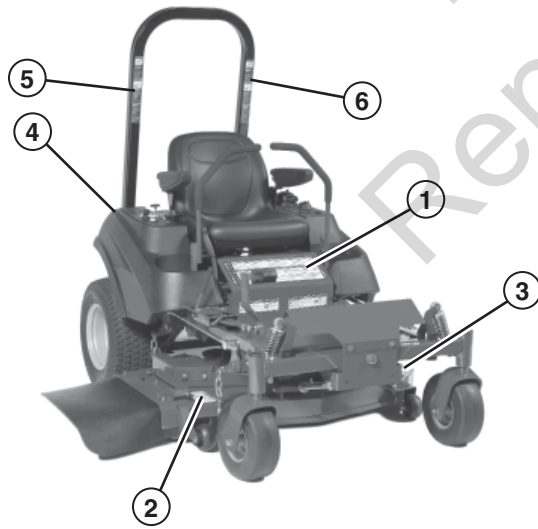

5

6



Safety Interlock System

This unit is equipped with safety interlock switches. These safety systems are present for your safety, do not attempt to bypass safety switches, and never tamper with safety devices. Check their operation regularly.

Operational SAFETY Checks

Test 1 — Engine should NOT crank if:

- PTO switch is engaged, OR
- Parking brake is not engaged, OR
- Motion control handles are not in the NEUTRAL position.

Test 2 — Engine SHOULD crank if:

- PTO switch is NOT engaged, AND
- Parking brake is engaged, AND
- Motion control handles are locked in the NEUTRAL position.

Test 3 — Engine should SHUT OFF if:

- Operator rises off seat with PTO engaged, OR
- Operator rises off seat with parking brake disengaged.
- Operator moves motion control handles out of their neutral positions before disengaging parking brake.

Test 4 — Blade Brake Check

Mower blades and mower drive belt should come to a complete stop within five (5) seconds after electric PTO switch is turned off (or operator rises off seat). If mower drive belt does not stop within five (5) seconds, see your dealer.

NOTE: Once the engine has stopped, PTO switch must be turned off, parking brake must be engaged, and the motion control handles must be locked in the NEUTRAL position after the operator returns to the seat in order to start the engine.

⚠ WARNING

If the unit does not pass a safety test, do NOT operate it. See your authorized dealer. Under no circumstance should you attempt to defeat the purpose of the safety interlock system.

Safety Icons

The alert symbol (⚠) is used to identify safety information about hazards that can result in personal injury. A signal word (DANGER, WARNING, or CAUTION) is used with the alert symbol to indicate the likelihood and the potential severity of the injury. In addition, a hazard icon may be used to represent the type of hazard. An explanation of hazard levels and icons are as follows:

⚠ DANGER
This indicates a hazard which, if not avoided, will result in serious injury or death.
⚠ WARNING
This indicates a hazard which, if not avoided, could result in serious injury or death.
⚠ CAUTION
This indicates a hazard which, if not avoided, might result in serious injury or death.
NOTICE
This message presented without the alert symbol indicates a situation where the unit or property could be damaged.

North American Safety Icons

Alert	Toxic Fumes	Read the Manual	Open Flame Hazard
Fire Hazard	Amputation - Rotating Parts	Amputation - Hand In Blade	Amputation - Foot In Blade
Thrown Objects	Hot Surface	Wear Protective Gear	Pinch Point
Rollover Hazard	Overhead Obstacles	Tipover	Dropoffs
Slippery Slopes	Keep Children Away	Kickback	Remove Key Before Servicing

Features and Controls

Identification Numbers



North American Models

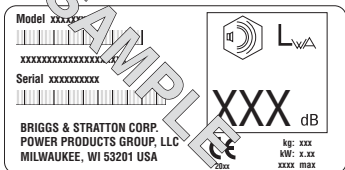

CE Models

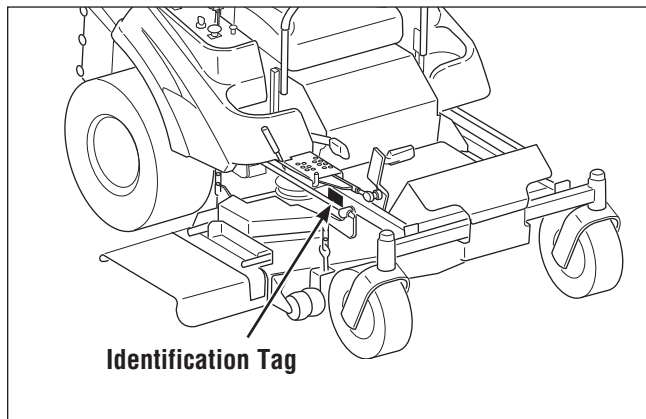

Identification Tag

When contacting your authorized dealer for replacement parts, service, or information you MUST have these numbers.

Record your model name/number, manufacturer's identification numbers, and engine serial numbers in the space provided for easy access. These numbers can be found in the locations shown.

NOTE: For location of engine identification numbers, refer to the engine owner's manual.

CE Identification Tag Markings

- A. Manufacturer's Identification Number
- B. Product Description
- C. Serial Number
- D. Manufacturer's Address
- E. CE Compliance Logo
- F. Year of Manufacture
- G. Maximum Engine Speed in Rotations per Minute
- H. Power Rating in Kilowatts
- I. Mass of Unit in Kilograms
- J. Sound Power in Decibels *

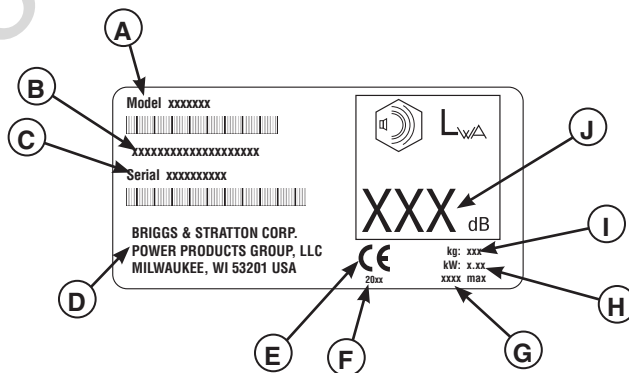

This unit complies with European Harmonized Lawn Mower Standard EN 836, European Machinery Directive 98/37/EC, and European EMC Directive 2004/108/EEC

* Tested according to 2000/14/EC

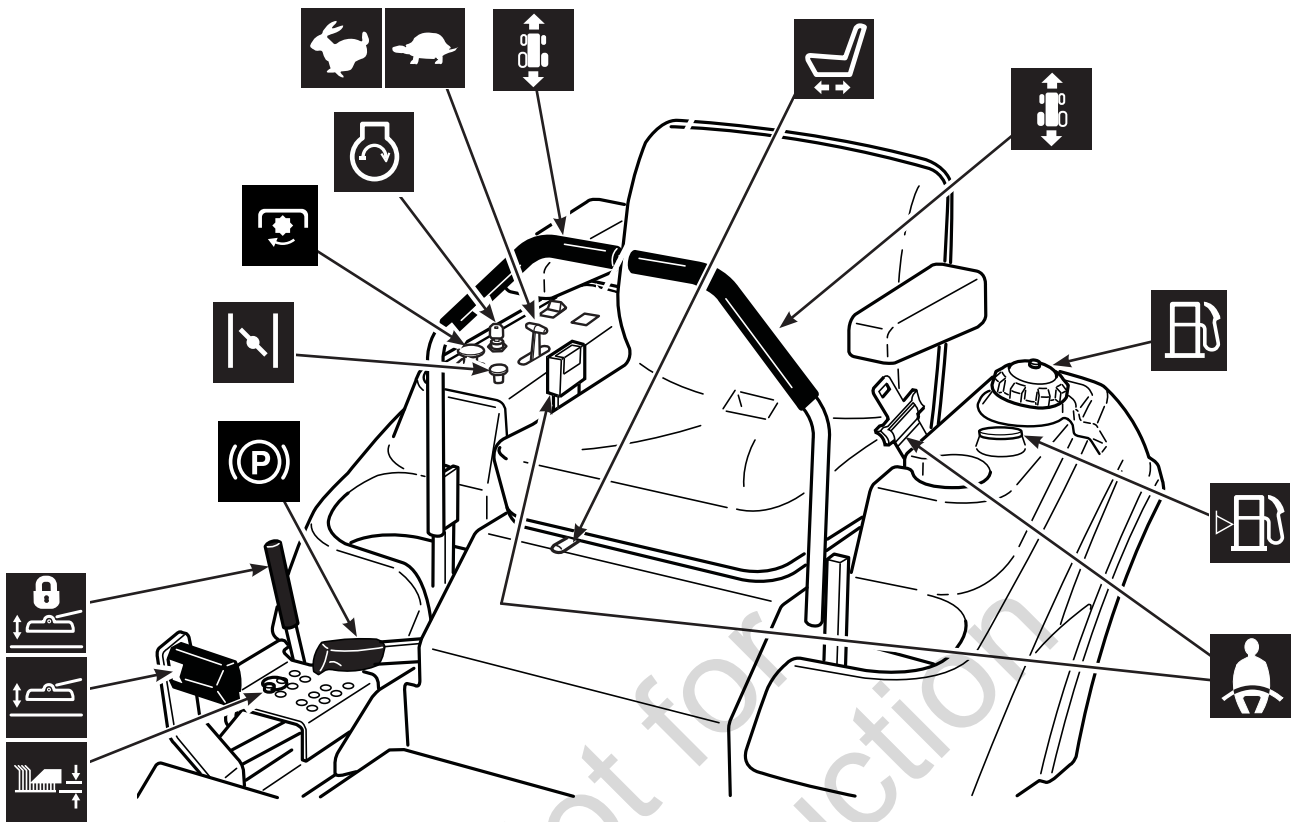

Control Functions

The information below briefly describes the function of individual controls. Starting, stopping, driving, and mowing require the combined use of several controls applied in specific sequences. To learn what combination and sequence of controls to use for various tasks see the OPERATION section.



Deck Lift Pedal, Cutting Height Adjustment Pin & Deck Lift Lock Lever

These control the cutting height of the mower deck. Depress the pedal until it locks into the 4-1/2" (11,4 cm) position. Place the adjustment pin in the desired cutting height and release the lift lock lever.



Parking Brake



DISENGAGE Releases the parking brake.



ENGAGE Locks the parking brake.

Pull the parking brake lever back to engage the parking brake. Move the lever fully forward to disengage the parking brake. *NOTE: To start the unit the parking brake must be engaged.*



Choke

Close the choke for cold starting. Open the choke once the engine starts. A warm engine may not require choking. Pull the knob UP to close the choke. Push to knob DOWN to open the choke.





PTO (Power Take Off) Switch

The PTO switch engages and disengages the mower. Pull UP on the switch to engage, and push DOWN to disengage.



Ignition Switch

The ignition switch starts and stops the engine, it has three positions:

-  OFF Stops the engine and shuts off the electrical system.
-  RUN Allows the engine to run and powers the electrical system.
-  START Cranks the engine for starting

NOTE: Never leave the ignition switch in the RUN position with the engine stopped-this drains the battery.



Throttle Control

The throttle controls engine speed. Move the throttle forward to increase engine speed and back to decrease engine speed. Always operate at FULL throttle



Ground Speed Control Levers

These levers control the ground speed of the rider. The left lever controls the left rear drive wheel and the right lever controls the right rear drive wheel.

Moving a lever forward increases the FORWARD speed of the associated wheel, and pulling back on a lever increases the REVERSE speed.

Note: The further a lever is moved away from the neutral position the faster the drive wheel will turn.

See the Operating the Zero Turn Rider section for steering instructions.



Hour Meter

The hour meter measures the number of hours the PTO has been engaged. The hour meter has a self contained power source so the total hours are always visible.



Seat Adjustment Lever

The seat can be adjusted forward and back. Move the lever towards the left, position the seat as desired, and release the lever to lock the seat in position.



Fuel Tank Cap

To remove the cap, turn counterclockwise.



Fuel Level Gauge

Displays the fuel level in the tank.



Retractable Seat Belt

The seat belt is used to secure the operator to the seat.

The seat belt should **always** be worn when using this equipment with a roll bar.

Operation

General Operating Safety

Before first time operation:

- Be sure to read all information in the Safety and Operation sections before attempting to operate this tractor and mower.
- Become familiar with all of the controls and how to stop the unit.
- Drive in an open area without mowing to become accustomed to the unit.

⚠ WARNING	
	<p>Operating on steep slopes can be dangerous.</p>
<ul style="list-style-type: none"> • Never operate on slopes greater than 15°. • Select slow ground speed before driving onto a slope. Use extra caution when operating on slopes with a rear-mounted grass catcher. • Mow across the face of slopes, not up and down, use caution when changing directions and DO NOT START OR STOP ON A SLOPE. 	

⚠ WARNING	
	
<ul style="list-style-type: none"> • Never allow passengers to ride on the unit. • Before leaving the operator's position for any reason, engage the parking brake, disengage the PTO, stop the engine and remove the key. • To reduce fire hazard, keep the engine, tractor and mower free of grass, leaves and excess grease. Do NOT stop or park tractor over dry leaves, grass or combustible materials. • Gasoline is highly flammable and must be handled with care. Never fill the tank when the engine is still hot from recent operation. Do NOT allow open flame, smoking or matches in the area. Avoid over-filling and wipe up any spills. 	

Checks Before Starting

- Check that crankcase is filled to full mark on dipstick (**B, Figure 1**). See the engine Operator's Manual for instructions and oil recommendations.
- Make sure all nuts, bolts, screws and pins are in place and tight.
- Adjust the seat position (**C**), and make certain you can reach all the controls from operator's position.
- Fill the fuel tank (**A**) with fresh fuel. Refer to the engine manual for fuel recommendations.

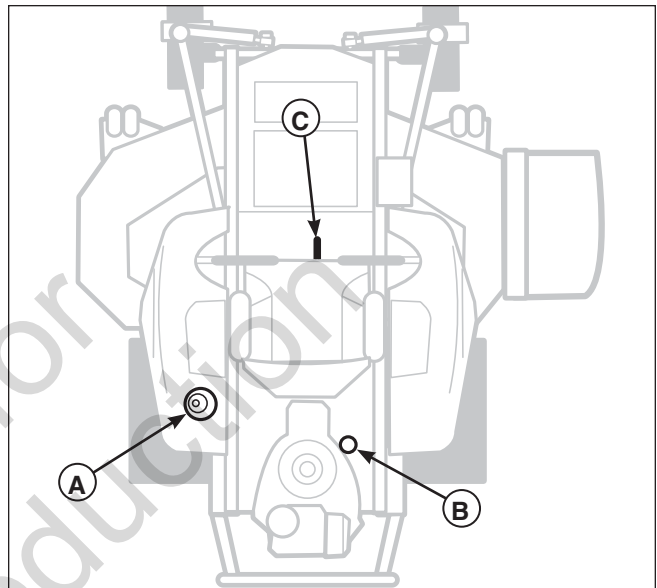

Figure 1. Pre-start Checks

- A. Fuel Tank Cap
- B. Crankcase Oil Fill
- C. Seat Adjustment Lever

⚠ WARNING	
<ul style="list-style-type: none"> • Do NOT load this zero-turn rider on a trailer or truck using two separate ramps. Only use a single ramp that is at least one foot wider than the width of the rear wheels of this rider. This rider has a zero turning radius and the rear wheels could fall off the ramps, or the rider could tip over injuring the operator or bystanders. 	
	

Check Tire Pressures

Tire pressure should be checked periodically, and maintained at the levels shown in the chart. Note that these pressures may differ slightly from the “Max Inflation” stamped on the side-wall of the tires. The pressures shown provide proper traction, improve cut quality, and extend tire life.

Tire	Serial Number	Pressure	
		psi	bar
Front	2013129510 & Below	40	2,76
Front	2013129511 & Above	25	1,72
Rear	All	15	1,03

Seat Adjustment

See Figure 3. The seat can be adjusted forward and back. Move the lever (**A, Figure 3**) towards the left, position the seat as desired, and release the lever to lock the seat into position.

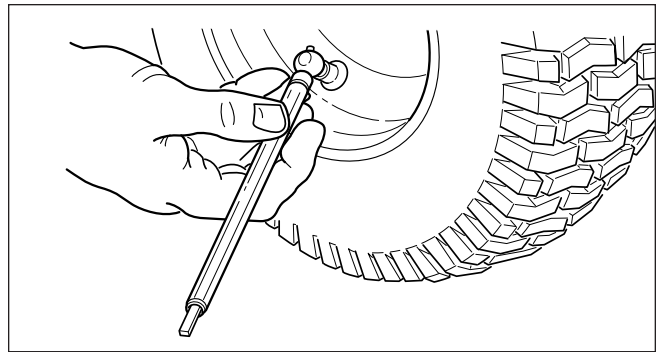

Figure 2. Checking Tire Pressure

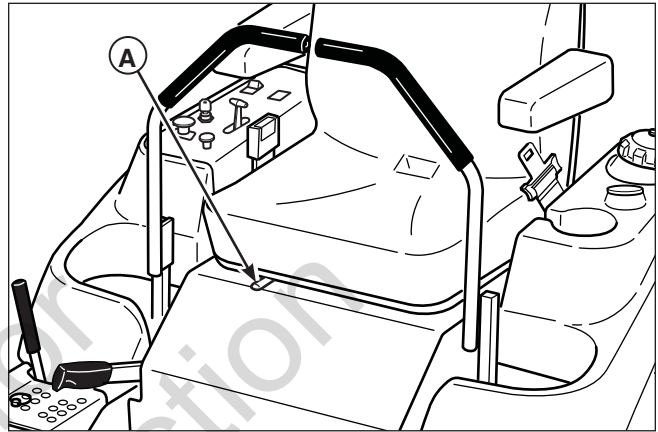

Figure 3. Seat Adjustment
A. Seat Adjustment Lever

Pushing the Rider by Hand

NOTICE

- Towing the unit will cause hydraulic pump and wheel motor damage.
- Do NOT tow rider.
- Do NOT use another vehicle to push or pull this unit.

1. Disengage the PTO, engage the parking brake, turn the ignition OFF, and remove the key.
2. Lift the seat plate to gain access to the hydraulic pumps.
3. To disengage the pumps (free-wheel position), turn the hydraulic release valves (**A, Figure 4**) located on the pumps COUNTER-CLOCKWISE a maximum of 2 full turns.
4. Disengage the parking brake.
The tractor can now be pushed by hand.
5. After moving the tractor, re-engage the pumps (drive position) by turning the release valves CLOCKWISE and tighten to 80-120 in. lbs. (9.04 - 13.56 Nm) of torque.

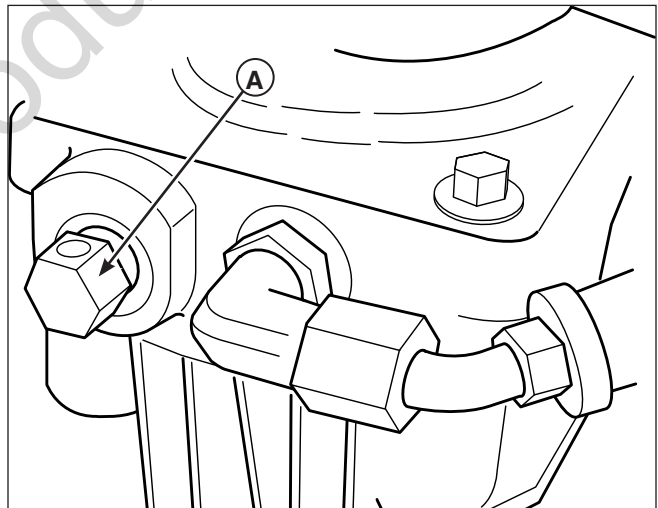

Figure 4. Hydraulic System By-Pass
A. Hydraulic Release Valve
(left-hand pump shown)

Mowing Height Adjustment

The cutting height adjustment pin (**A, Figure 5**) controls the mower cutting height. The cutting height is adjustable between 1-3/4" (4,4 cm) and 4-1/2" (11,4 cm) in 1/4" (0,64 cm) increments.

1. Depress the deck lift foot pedal (**B**) until it locks into the 4-1/2" (11,4 cm) position.
2. Place the cutting height adjustment pin in the desired cutting height.
3. Depress the deck lift foot pedal then push the lock lever (**C**) towards the right to release the lock.
4. Release the deck lift foot pedal until it comes to rest against the cutting height adjustment pin.

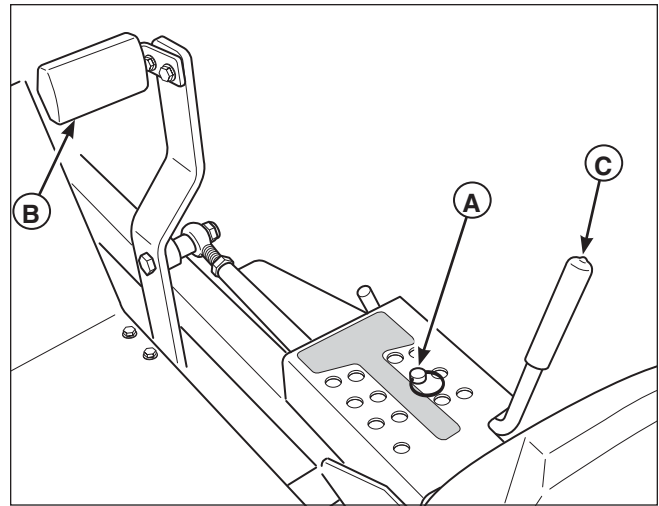

Figure 5. Mowing Height Adjustment

- A. Cutting Height Adjustment Pin
- B. Deck Lift Foot Pedal
- C. Deck Lift Lock Lever

Foot Pedal Adjustment

The deck lift foot pedal can be adjusted to accommodate the operator's height for optimal comfort.

To Adjust Pedal Position:

1. Remove the foot pedal (**A, Figure 6**) from the pedal mount tab (**B**).
2. Remove the pedal mount hardware (**C**) and rotate the tab 180 degrees.
3. Reinstall the pedal mount hardware and tighten securely.
4. Reinstall the foot pedal on the pedal mount tab in the proper orientation as shown in Figure 6.

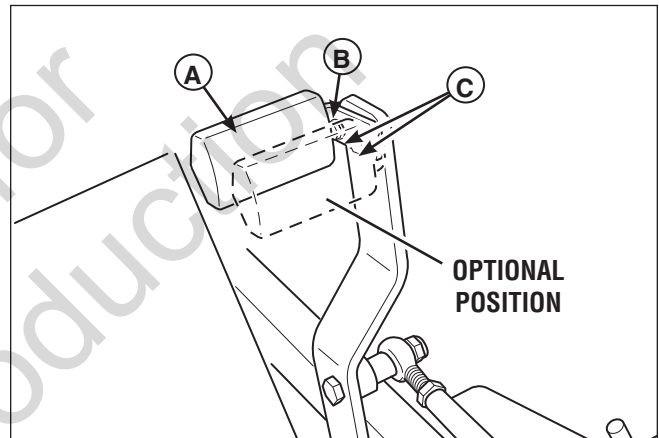

Figure 6. Foot Pedal Adjustment

- A. Deck Lift Foot Pedal
- B. Pedal Mount Tab
- C. Pedal Mount Hardware

⚠ WARNING**Read the Operator's Manual before attempting to operate the machine.**

- If you do not understand how a specific control functions, or have not yet thoroughly read the FEATURES and CONTROLS section, do so now.
- Do NOT attempt to operate the tractor without first becoming familiar with the location and function of ALL controls.

Starting the Engine

1. While sitting in the operator's seat, engage the parking brake and make sure the PTO switch is disengaged and the motion control handles are locked in the NEUTRAL position.
2. **NOTE: A warm engine may not require choking.**
Set the engine throttle control to FAST throttle position. Then fully close the choke by pulling the knob OUT fully.
3. Insert the key into the ignition switch and turn it to START.
4. After the engine starts, gradually open the choke (push knob down fully). Reduce to half throttle speed and allow to warm up.

Warm up the engine by running it for at least a minute before engaging the PTO switch or driving the rider.

5. **After warming the engine, ALWAYS operate the unit at FULL THROTTLE when mowing.**

In the event of an emergency the engine can be stopped by simply turning the ignition switch to STOP.

Use this method only in emergency situations. For normal engine shut down follow the procedure given in STOPPING THE RIDER.

Stopping the Rider

1. Returning the ground speed control levers to the middle position will stop rider movement. Pivot the levers outward and lock them in NEUTRAL.
2. Disengage the PTO by pushing down on the PTO switch.
3. Engage the parking brake by pulling the handle up until it locks into position.
4. Move the throttle control to mid-throttle position and turn the ignition key to OFF. Remove the key.

Zero-Turn Driving Practice

The lever controls of the Zero Turn rider are responsive, and learning to gain a smooth and efficient control of the rider’s forward, reverse, and turning movements will take some practice.

Spending some time going through the maneuvers shown and becoming familiar with how the unit accelerates, travels, and steers — before you begin mowing — is absolutely essential to getting the most out of the Zero Turn rider.

Locate a smooth, flat area of your lawn — one with plenty of room to maneuver. (Clear the area of objects, people and animals before you begin.) Operate the unit at mid-throttle during this practice session (ALWAYS operate at full throttle when mowing), and turn slowly to prevent tire slippage and damage to your lawn.

We suggest you begin with the Smooth Travel procedure to the right, and then advance through the forward, reverse, and turning maneuvers.

You must release the parking brake prior to moving the control levers inward.

Smooth Travel

The lever controls of the Zero Turn rider are responsive.

The BEST method of handling the ground speed control levers is in three steps — as shown in Figure 7.

FIRST place your hands onto the levers as shown.

SECOND, to go forward gradually push the levers forward with your palms.

THIRD, to speed up move the levers farther forward. To slow down smoothly, slowly move the levers toward neutral.

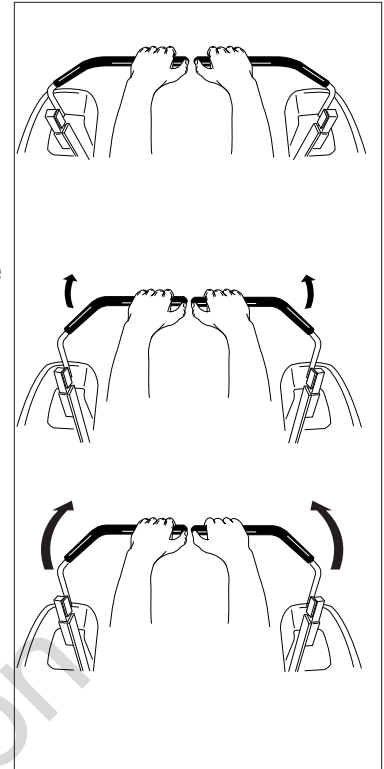

Figure 7. Move Control Levers Gradually

Basic Driving

Forward Travel Practice

Gradually move both ground speed control levers — evenly FORWARD from neutral. Slow down and repeat.

NOTE: Straight forward travel takes practice. If necessary, top speed can be balance-adjusted — see the Speed Balancing Adjustment in the Adjustments section near the back of this manual.

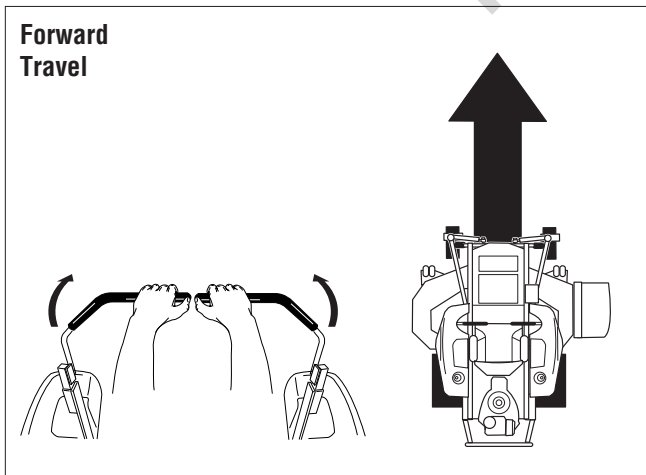

Figure 8. Forward Travel

Reverse Travel Practice

LOOK DOWN & BEHIND, then gradually move both ground speed control levers evenly BACK from neutral. Slow down and repeat.

NOTE: Practice backing up for several minutes before attempting to do so near objects. The rider turns sharply in reverse as well as forward, and backing up straight takes practice.

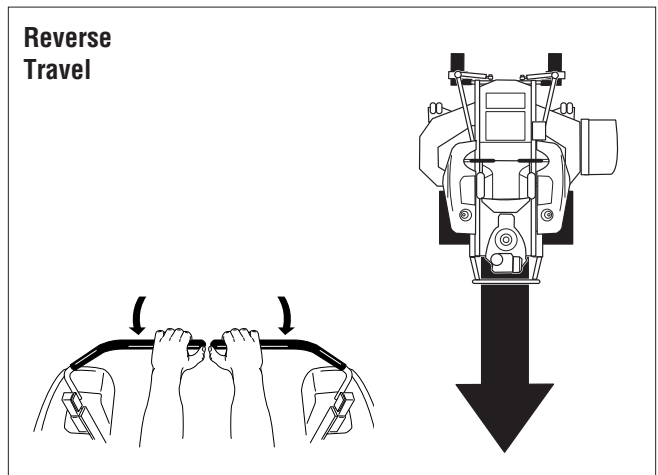

Figure 9. Reverse Travel

Practice Turning Around a Corner

While traveling forward allow one handle to gradually return back toward neutral. Repeat several times.

NOTE: To prevent pivoting directly on the tire tread, it is best to keep both wheels going at least slightly forward.

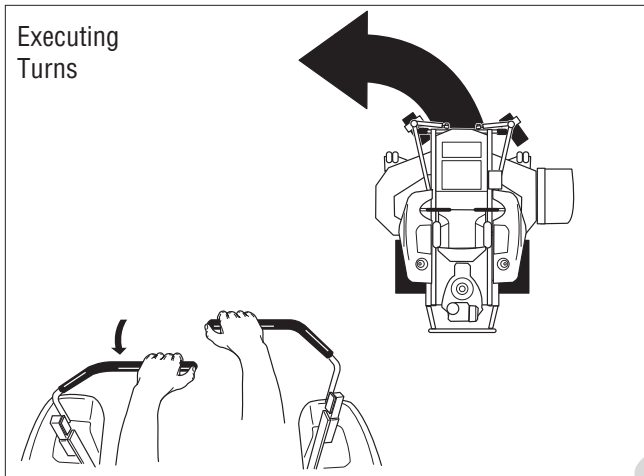

Figure 10. Turning Around a Corner

Practice Turning In Place

To turn in place, “Zero Turn,” gradually move one ground speed control lever forward from neutral and one lever back from neutral simultaneously. Repeat several times.

NOTE: Changing the amount each lever is pulled—forward or back, changes the “pivot point” you turn on.

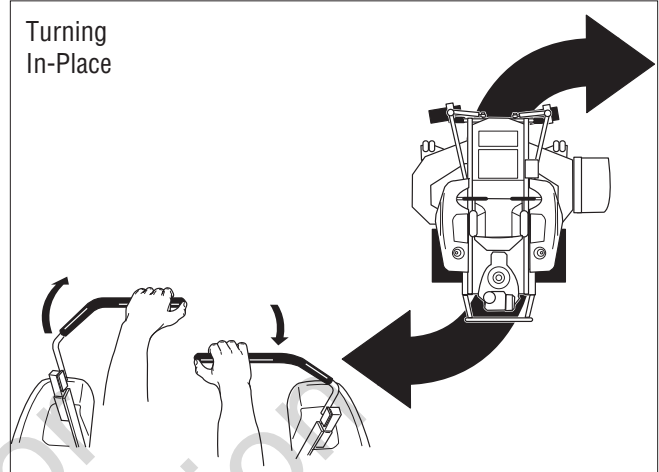

Figure 11. Turning in Place

Advanced Driving

Executing an End-Of-Row Zero Turn

Your Zero Turn Rider’s unique ability to turn in place allows you to turn around at the end of a cutting row rather than having to stop and Y-turn before starting a new row.

For example, to execute a left end-of row zero turn:

1. Slow down at the end of the row.
2. Move the RIGHT ground speed control lever forward slightly while moving the LEFT ground speed control lever back to center and then slightly back from center.
3. Begin mowing forward again.

This technique turns the rider LEFT and slightly overlaps the row just cut—eliminating the need to back up and re-cut missed grass.

As you become more familiar and experienced with operating the Zero Turn rider, you will learn more maneuvers that will make your mowing time easier and more enjoyable.

Remember, the more you practice, the better your control of the Zero Turn will be!

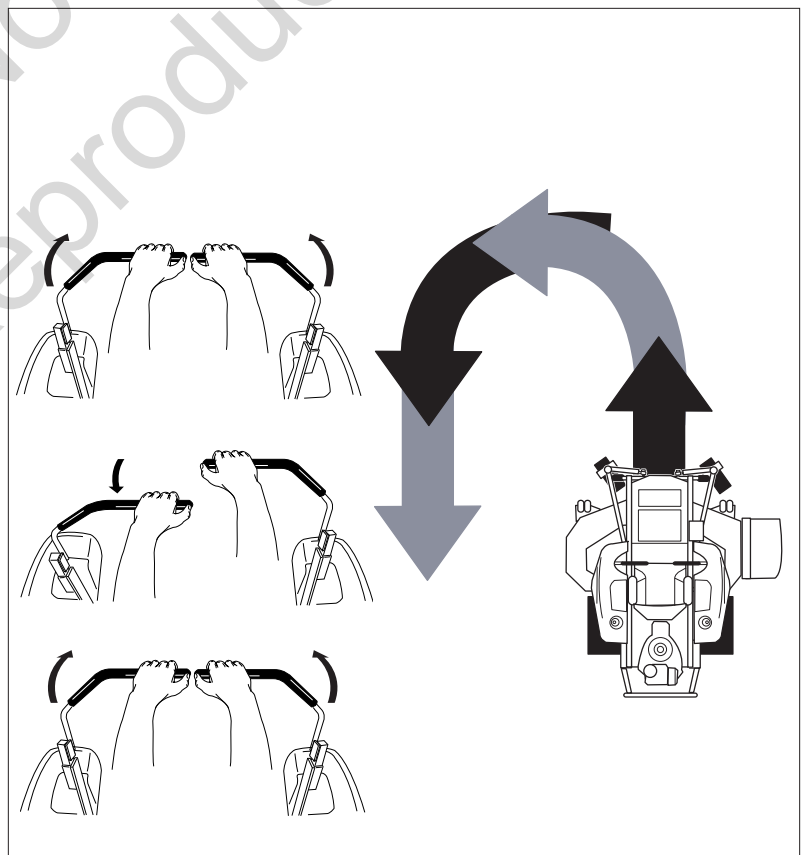



Figure 12. Executing an End-Of-Row Turn

Storage

⚠ WARNING	
 	<p>Fuel and its vapors are extremely flammable and explosive.</p> <p>Fire or explosion can cause severe burns or death.</p>
<ul style="list-style-type: none"> • Never store the unit, with gasoline in the engine or fuel tank, in a heated shelter or in enclosed, poorly ventilated enclosures. Gasoline fumes may reach an open flame, spark or pilot light (such as a furnace, water heater, clothes dryer, etc.) and cause an explosion. • Handle gasoline carefully. It is highly flammable and careless use could return in serious fire damage to your person or property. • Drain fuel into an approved container outdoors away from open flame or sparks. 	

Before you store your unit for the off-season, read the Maintenance and Storage instructions in the Safety Rules section, then perform the following steps:

- Disengage the PTO, set the parking brake, & remove the key.
- Perform engine maintenance and storage measures listed in the engine owner’s manual. This includes draining the fuel system, or adding stabilizer to the fuel (do not store a fueled unit in an enclosed structure - see warning).
- Battery life will be increased if it is removed, put in a cool, dry place and fully charged about once a month. If the battery is left in the unit, disconnect the negative cable.

Before starting the unit after it has been stored:

- Check all fluid levels. Check all maintenance items.
- Perform all recommended checks and procedures found in engine owner’s manual.
- Allow the engine to warm up for several minutes before use.

Mowing

Before mowing, set the cutting height as described in the *Operation* section.

1. Engage the parking brake. Make sure the PTO switch is disengaged and the ground speed control levers are in the NEUTRAL position.
2. Start the engine (see STARTING THE ENGINE).
3. Set the throttle to FULL.
4. Engage the PTO by pulling up on the PTO switch.
5. Begin mowing. See *Mowing Recommendations* section for tips on mowing patterns and lawn care. See Troubleshooting section for information on troubleshooting common cutting problems.
6. When finished, shut off the PTO.
7. Stop the engine (see STOPPING THE TRACTOR AND ENGINE).

Height of Grass

Often cutting height is a matter of personal preference. Typically, you should mow the grass when it is between three and five inches high. The proper cutting height range for a specific lawn will depend upon several factors, including the type of grass, the amount of rainfall, the prevailing temperature, and the lawn’s overall condition.

Cutting the grass too short causes weak, thin grass plants, which are easily damaged by dry periods and pests. Cutting too short is often more damaging than allowing the grass to be slightly higher.

Letting grass grow a bit longer—especially when it is hot and dry—reduces heat build-up, preserves needed moisture and protects the grass from heat damage and other problems. However, allowing grass to grow too high can cause thin turf and additional problems.

Cutting off too much at one time shocks the plant’s growth system and weakens the grass plants. **A good rule of thumb is the 1/3 rule: to cut no more than one third of the grass height, and never more than 1 inch at a time.**

Mowing Recommendations

Several factors can affect how well your machine cuts grass. Following proper mowing recommendations can improve the performance and life of your machine.

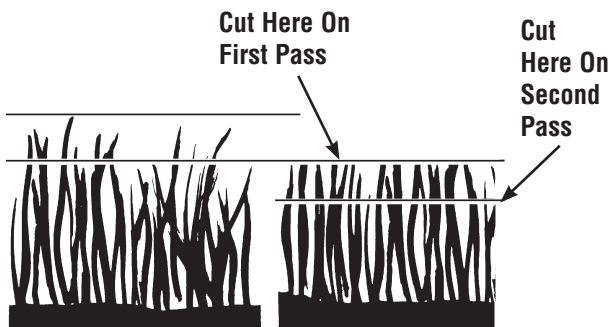

Figure 14. Incremental Cutting

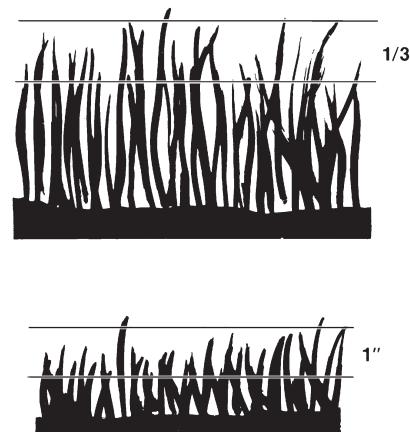

Figure 15. Proper Cutting Height

The amount of grass you are able to cut in one pass is also effected by the type of mowing system you are using (for example, broadcasting with side discharge decks can process a much larger volume of grass than mulching does).

Tall Grass Requires Incremental Cutting

For extremely tall grass, set the cutting height at maximum for the first pass, and then reset it to the desired height and mow a second or third time.

Don't cover the grass surface with a heavy layer of clippings. Consider using a grass collection system and starting a compost pile.

When and How Often to Mow

The time of day and condition of the grass greatly affect the results you'll get when mowing. For the best results, follow these guidelines:

1. Mow when the grass is between three and five inches high.
2. Mow with sharp blades. Short clippings of grass one inch or shorter decompose more quickly than longer blades. Sharp mower blades cut grass cleanly and efficiently, preventing frayed edges which harm the grass.
3. Mow at time of day when the grass is cool and dry. Late afternoon or early evening often provide these ideal mowing conditions.
4. Avoid mowing after rain or even heavy dew, and never mulch when the grass is wet (moist grass does not mulch well, and clumps beneath the mower deck).

Mowing Patterns

Always start mowing on a smooth, level area.

The size and type of area to be mowed will determine the best mowing pattern to use. Obstructions such as trees, fences and buildings, and conditions such as slopes and grades must also be considered.

1. Cut long straight strips overlapping slightly.
2. Where possible, change patterns occasionally to eliminate matting, graining or a corrugated appearance.
3. For a truly professional cut, mow across the lawn in one direction, then recut the lawn by mowing perpendicular to the previous cut.

Note: Always operate the engine at full throttle when mowing.

If you hear the engine slowing down, you are mowing too fast—using a slower ground speed will improve the cutting efficiency of the blades and prevents many common cutting problems. Use an appropriate ground speed for the thickness and height of the grass you are cutting (3rd gear or slower for manual gear models). If you hear the engine slowing down you are mowing too fast, use a slower ground speed.

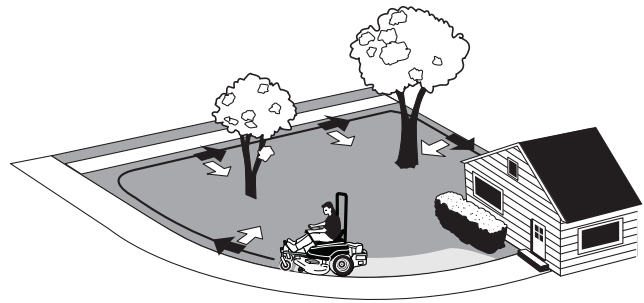

Where possible, make one or two passes around the outside of the area discharging the grass INTO the lawn to keep the cut grass off fences and walks.

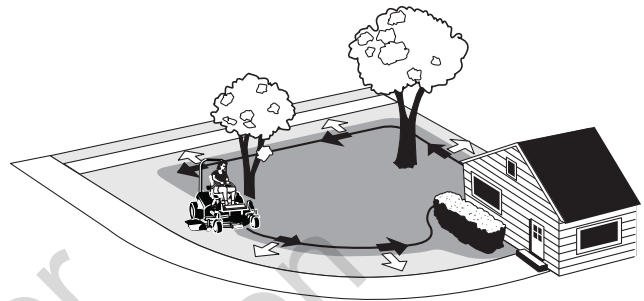

The remainder of the mowing should be done in the opposite direction so that the clippings are dispersed OUT onto the area of lawn previously cut.

Mowing Methods

Proper Broadcast Mowing

Broadcasting, or side-discharging, disperses fine clippings evenly over the entire lawn. Many golf courses use this method. Your mower has a deep dish deck to allow freer circulation of clippings so they are broadcast evenly over the lawn.

Engine Speed & Ground Speed for Broadcasting

Always operate the engine at full throttle when mowing. If you hear the engine slowing down, you are mowing too fast—using a slower ground speed will improve the cutting efficiency of the blades and prevents many common cutting problems.

ALWAYS use an appropriate ground speed for the thickness and height of the grass you are cutting (3rd gear or slower for manual gear models). If you hear the engine slowing down you are mowing too fast, use a slower ground speed.

How Much Grass to Cut Off When Broadcasting

Mow when the grass is 3-5 inches long. Do not cut the grass shorter than 2 to 2-1/2 inches. Do not cut off more than 1 inch of grass in a single pass

Proper Mulching

Mulching consists of a mower deck which cuts and recuts clippings into tiny particles and which then blows them down INTO the lawn. These tiny particles decompose rapidly into by-products your lawn can use. UNDER PROPER CONDITIONS, your mulching mower will virtually eliminate noticeable clippings on the lawn surface.

NOTE: When mulching under heavy cutting conditions, a rumbling sound may be present and is normal.

Mulching Requires EXCELLENT Mowing Conditions

Mulching mowers cannot function properly if the grass is wet, or if the grass is simply too high to cut. Even more than normal mowing, mulching requires that the grass be dry and the appropriate amount is cut.

Do not use the mower as a mulching mower during the first two or three mowings in the spring. The long grass blades, quick growth, and often wetter conditions are more suitable for broadcasting (side-discharging) or grass bagging operation.

Engine Speed & Ground Speed for Broadcasting

Use full engine throttle matched with a slow ground speed so that clippings will be finely cut. Ground speed while mulching should be HALF of the speed that would be used when broadcasting (side discharging) under similar conditions. Since mulching requires more horsepower than broadcasting, using a slower ground speed is vitally important for proper mulching operation.

How Much Grass to Mulch

The best mulching action typically results from cutting only the top 1/2 inch to 3/4 inch of grass blade. This provides short clippings which decompose properly (much more quickly than longer clippings). The ideal cutting height will vary with climate, time of year, and quality of your lawn. We recommend that you experiment with both the cutting height and ground speed until you achieve the best cut. Start with a high cutting height and using progressively lower settings until you find a cutting height that is matched to your mowing conditions and preferences.

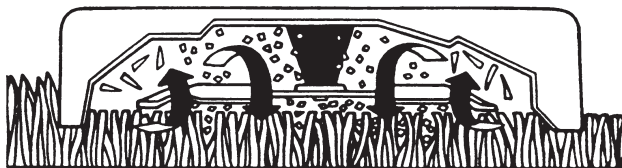

Figure 16. Mulching Action

Attaching a Trailer

The maximum weight of a towed trailer should be less than 200 lbs (91kg). Secure the trailer with an appropriately sized clevis pin (A, Figure 17) and clip (B).

Excessive towed loads can cause loss of traction and loss of control on slopes. Reduce towed weight when operating on slopes. The surface being driven on greatly impacts traction and stability. Wet or slippery surfaces can greatly reduce traction and the ability to stop or turn. Carefully evaluate the surface conditions before operating the unit and trailer, and never operate on slopes greater than 10°. See SLOPE OPERATION and TOWED EQUIPMENT in the safety section of this manual for additional safety information.

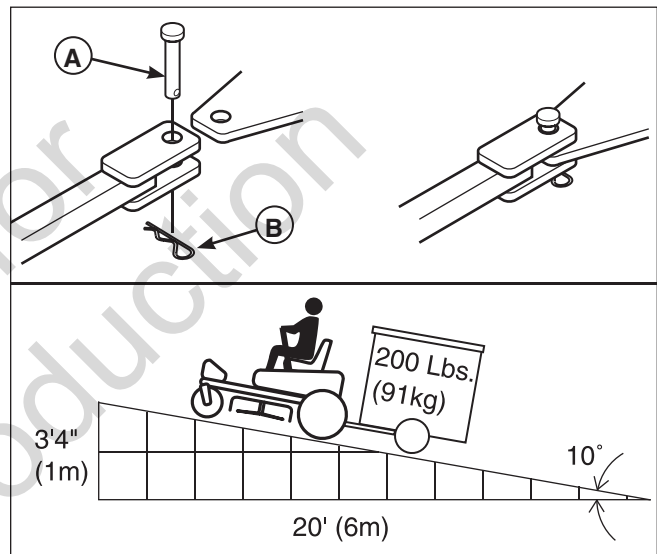

Figure 17. Trailer Weight Recommendations

- A. Clevis Pin
- B. Clip

Regular Maintenance

Maintenance Schedule

The following schedule should be followed for normal care of your rider and mower. You will need to keep a record of your operating time. Determining operating time is easily accomplished by observing the elapsed time recorded by the hour meter.

MOWER MAINTENANCE
Before Each Use
Check Safety Interlock System
Check Rider Brakes
Check Rider / Mower for loose hardware
Check Hydraulic Oil
Every 25 Hours
Check Deck & Check / Replace Mower Blades*
Lubricate Rider & Mower*
Check Tire Pressure
Every 100 Hours
Check Mower Blade Stopping Time
Clean Battery & Cables
Every 250 Hours
Change Hydraulic Oil & Filter*

* More often in hot (over 85° F: 30° C) weather or dusty operating conditions.

ENGINE MAINTENANCE
Before Each Use
Check Engine Oil Level
Every 25 Hours
Check / Clean Cooling Fins & Intake*
Every 50 Hours
Check Clean Spark Arrester**
Refer to Engine Owner's Manual
Service Air Filter
Change Oil & Filter
Check / Replace Spark Plugs
Check / Replace Fuel Filter

* More often in hot (over 85° F: 30° C) weather or dusty operating conditions.

** If equipped replace if damaged.

Checking / Adding Fuel

To add fuel:

1. Stop the engine and allow to cool for at least 3 minutes.
2. Remove the fuel cap (see **Figure 1**).
3. Fill the tank to the bottom of the filler neck. This will allow for fuel expansion.

NOTE: Do not overfill. Refer to your engine manual for specific fuel recommendations.

4. Install and hand tighten the fuel cap.

Fuel Filter

The fuel filter is located in the fuel line between fuel tank and carburetor, near the fuel pump. If filter is dirty or clogged, replace as follows:

1. Disconnect the negative battery cable.
2. Place a container below the filter to catch spilled fuel.
3. Using a pliers, open and slide hose clamps from fuel filter.
4. Remove hoses from filter.
5. Install new filter in proper flow direction in fuel line.
6. Secure with hose clamps.
7. Reconnect the negative battery cable when finished.

Change Oil & Filter

1. Warm engine by running for a few minutes. (Refer to the engine operator's manual for oil & filter replacement instructions.)
2. Remove the oil drain hose (**A, Figure 18**) from the cable clamp (**B**) on the right-hand side of the frame and route the hose through hole in the engine deck as shown in **Figure 15**.
3. Place a small pan under the oil drain hose to catch the oil. Using the appropriate tools, remove the cap (**C**) from the oil drain hose (**A**) and drain the engine oil.
4. After draining, replace the cap and wipe up any spilled oil. Reinstall the oil drain hose into the cable clamp to retain the hose during normal operation.
5. Place an absorbent shop cloth under the engine oil filter. Remove the engine oil filter and replace with a new one.
6. Remove the shop cloth and wipe up any spilled oil.

Inspect Muffler and Spark Arrester

Inspect the muffler for cracks, corrosion, or other damage. Remove the spark arrester, if equipped, and inspect for damage or carbon blockage. If replacement parts are required, make sure to use only original equipment replacement parts.

⚠ WARNING

Replacement parts must be the same and installed in the same position as the original parts or fire could result.

⚠ WARNING



Fuel and its vapors are extremely flammable and explosive.
Fire or explosion can cause severe burns or death.

- Gasoline is highly flammable and must be handled with care. Never fill the tank when the engine is still hot from recent operation. Do NOT allow open flame, smoking or matches in the area. Avoid over-filling and wipe up any spills.
- Do NOT remove fuel filter when engine is hot, as spilled gasoline may ignite. Do NOT spread hose clamps further than necessary. Ensure clamps grip hoses firmly over filter after installation.

NOTICE

Do NOT use gasoline containing METHANOL, gasohol containing more than 10% ethanol, gasoline additives, premium gasoline, or white gas because engine/fuel system damage could result.

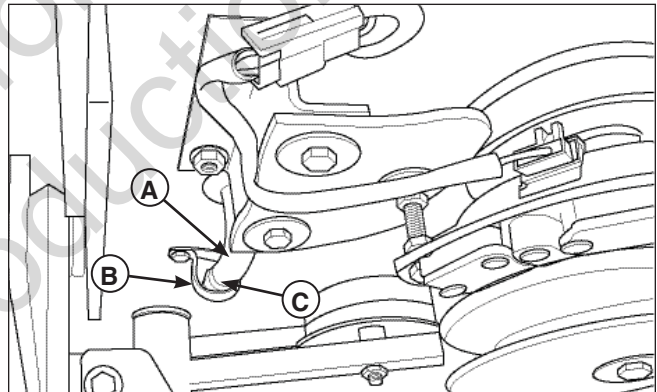

Figure 18. Engine Oil Drain

- A. Oil Drain Hose
- B. Cable Clamp
- C. Cap

Battery Charging

A dead battery or one too weak to start the engine may be the result of a defect in the charging system or other electrical component. If there is any doubt about the cause of the problem, see your dealer. If you need to replace the battery, follow the steps under Cleaning the Battery & Cables in the **Regular Maintenance** section.

To charge the battery, follow the instructions provided by the battery charger manufacturer as well as all warnings included in the safety rules section of this book. Charge the battery until fully charged (until the specific gravity of the electrolyte is 1.250 or higher and the electrolyte temperature is at least 60° F). Do not charge at rate higher than 10 amps.

Check Hydraulic Oil Level

1. Before removing the reservoir cap, make sure the area around the reservoir cap and fill neck of the reservoir is free of dust, dirt, or other debris.
2. Unscrew the reservoir cap (**B, Figure 19**).
3. Look down the filler neck of the hydraulic oil reservoir (**A**) and observe the oil level. When cold, the oil level should be approximately 4" (10 cm) below top of the filler neck.
4. If necessary, add SAE 20W-50 motor oil. **DO NOT** use synthetic oils.
5. Reinstall the reservoir cap.

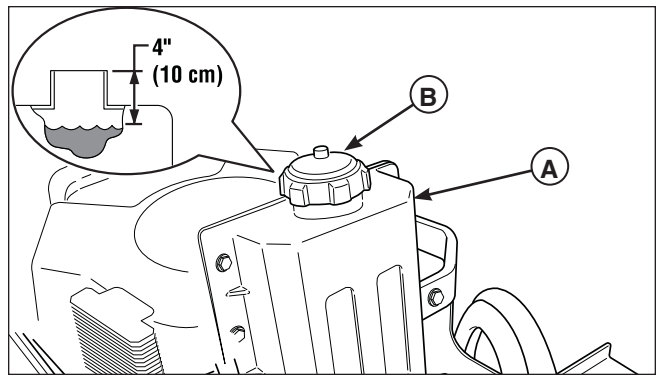

Figure 19. Checking Hydraulic Oil Level
 A. Hydraulic Oil Reservoir
 B. Reservoir Cap

Change Hydraulic Oil Filter

Change Interval: Every 250 Hours

Filter Part Number: 1719168

NOTE: Removing the oil filter from the filter base will drain the oil reservoir. Have a suitable container ready to catch any spilled oil. Simplicity recommends this be a dealer-only service item.

1. Locate the transmission oil filter (**A, Figure 20**).
2. Lubricate the new filter base with a few drops of transmission oil. Fill the filter half full of oil.
3. Clean the area around the filter base and remove the filter. Do NOT drain the hydraulic system oil.
4. Thread the new filter onto the filter base until the gasket makes contact, then tighten 3/4 of a turn more.
5. Run the unit for several minutes and check the transmission oil level.

IMPORTANT NOTE: Use caution after changing the filter; air in the hydraulic system may affect the responsiveness of the control levers. Repeat step 5 until the air is out of the system.

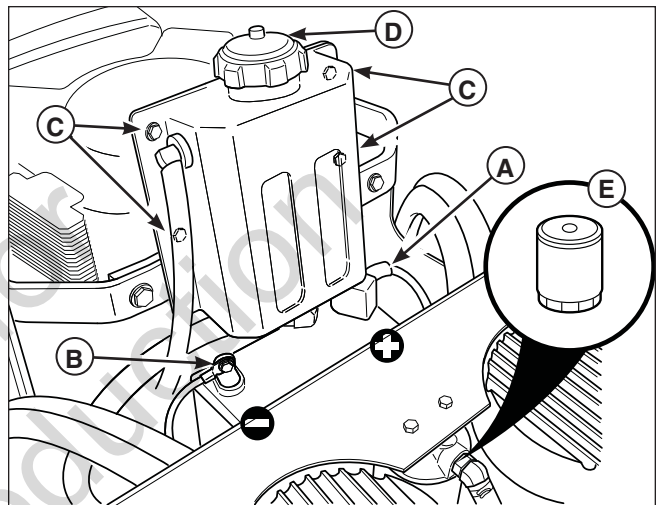



Figure 20. Battery Compartment
 A. Positive (+) Cable & Terminal
 B. Negative (-) Cable & Terminal
 C. Reservoir Mounting Hardware
 D. Hydraulic Oil Reservoir
 E. Hydraulic Oil Filter

Battery Maintenance

NOTE: This unit is equipped with a maintenance-free BCIU1 battery.

Cleaning the Battery and Cables

1. Remove the hydraulic oil reservoir mounting hardware (**C, Figure 20**) and then move the reservoir (**D**) forward to expose the battery.
2. Disconnect the cables from the battery, negative (black) cable first (**B**).
3. Clean the battery terminals and cable ends with a wire brush until shiny.
4. Reinstall the battery and reattach the battery cables, positive (red) cable first (**A**).
5. Coat the cable ends and battery terminals with petroleum jelly or non-conducting grease.
6. Reposition the oil reservoir and secure in place with the hardware previously removed.

⚠ WARNING	
	Keep open flames and sparks away from the battery.
<ul style="list-style-type: none"> • Be careful when handling the battery. Avoid spilling electrolyte. Keep flames and sparks away from the battery. • When removing or installing battery cables, disconnect the negative cable FIRST and reconnect it LAST. If not done in this order, the positive terminal can be shorted to the frame by a tool. 	

Lubrication

Lubricate the unit at the locations shown in Figures 21 through 25 as well as the following lubrication points.

Grease:



- front caster wheel axles & yokes
- deck lift pivot blocks
- mower deck spindles
- mower deck idler arm

Use grease fittings when present. Disassemble parts to apply grease to moving parts when grease fittings are not installed.

Not all greases are compatible. Use automotive-type lithium grease.

Oil:



- control handle pivots
- seat plate pivots
- deck lift pivots
- discharge chute hinge

Generally, all moving metal parts should be oiled where contact is made with other parts. Keep oil and grease off belts and pulleys. Remember to wipe fittings and surfaces clean both before and after lubrication.

Lubricating the Front Casters:

Front casters should be lubricated annually.

1. Remove the 1/4-28 bolt (A, Figure 24) screwed into the front caster and install a 1/4-28 grease fitting.
2. Grease the front caster.
3. Remove the 1/4-28 grease fitting and reinstall the 1/4-28 bolt.
4. Repeat process for the other side of the machine.

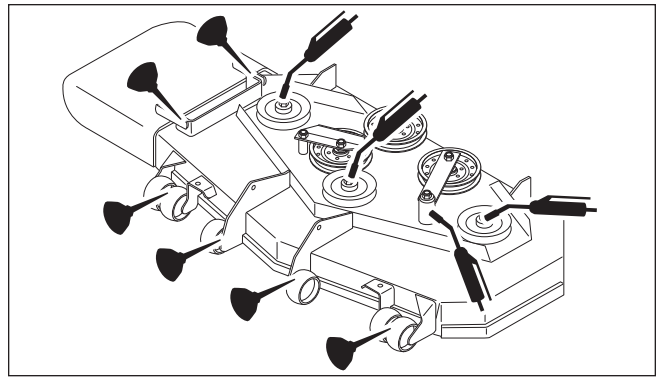

Figure 21. Deck Lubrication

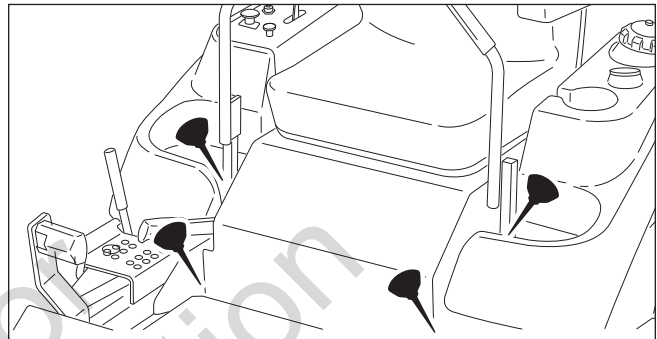

Figure 22. Control Handle Pivots & Seat Plate Pivots

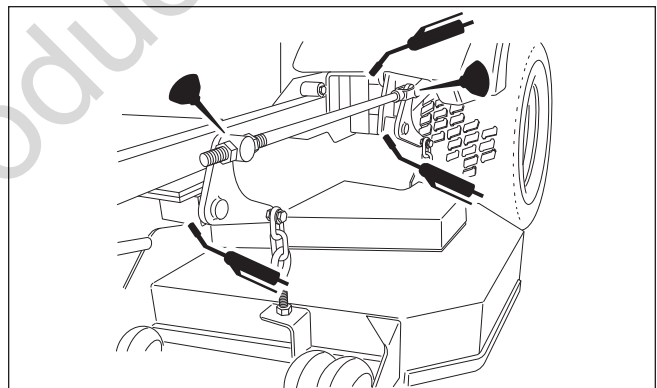

Figure 23. Deck Lift Linkage Pivots

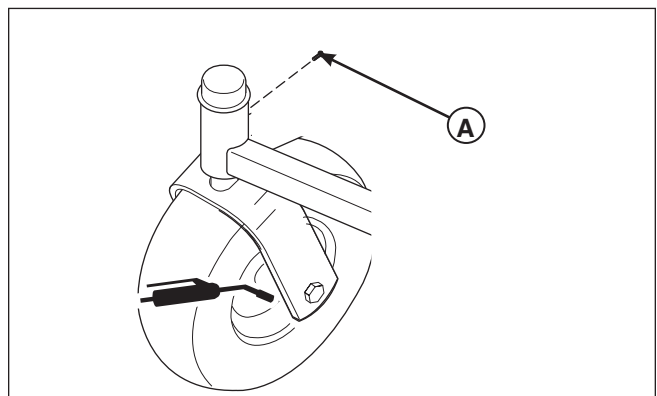



Figure 24. Front Caster & Wheel
A. 1/4-28 Bolt

Servicing The Mower Blades

Removing the Mower Blade

⚠ WARNING	
	Avoid injury! Mower blades are sharp.
Always wear gloves when handling mower blades or working near blades.	

1. Wedge a wooden block between the mower blade and the mower deck housing to keep the mower blade from turning.
2. To remove the mower blade, use a 15/16" wrench to remove the mower blade mounting bolt (**Figure 25**).

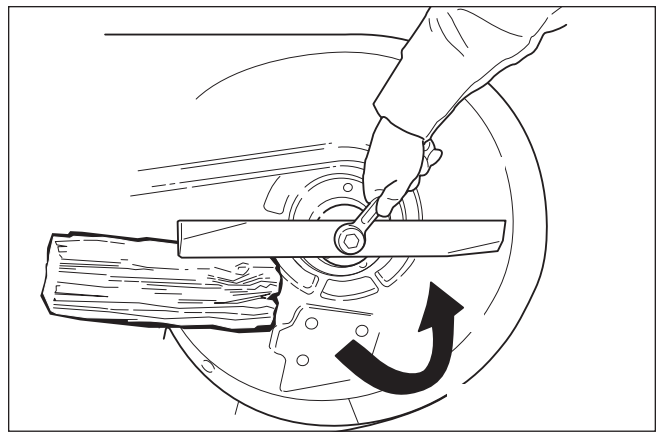



Figure 25. Loosening the Mower Blade for Removal

Inspecting the Mower Blades

⚠ WARNING	
	Avoid injury! A worn or damaged blade can break, and a piece of the mower blade could be thrown into the operator's or bystander's area, resulting in serious personal injury or death.
<ul style="list-style-type: none"> • Inspect the mower blade every 25 hours or atleast once a year. • If the mower blade hits a solid object, stop the engine immediately and inspect the mower blades. • Never weld or straighten bent mower blades. 	

1. Inspect the mower blade (**Figures 26 & 27**). **Discard the mower blade if it has any of the below conditions.**
 - Has more than .5" (12,7 mm) of the mower blade metal removed from previous sharpening or wear (**D**, **Figure 27**).
 - The air lifts are excessively eroded (**B & C**, **Figure 27**) and the notch (**C**) is .25" (6,35 mm) deep or greater.
 - Mower blade is bent or broken.
2. If the cutting edges are not sharp or have nicks, sharpen the blades. *See Sharpening the Mower Blades.*

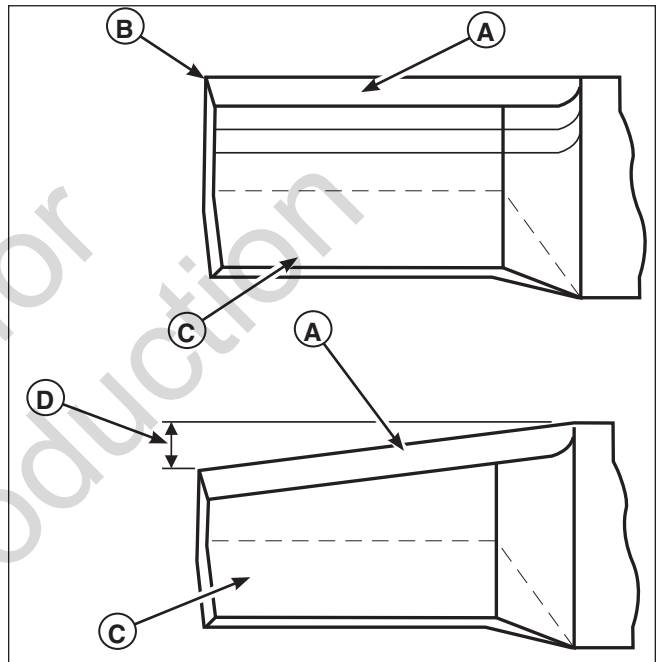

Figure 26. Inspecting the Mower Blade Tips

- A. Mower Blade Cutting Edge
- B. Square Corner
- C. Air Lift
- D. Wear Measurement - **DISCARD Mower Blade If greater than .5" (12,7 mm)**

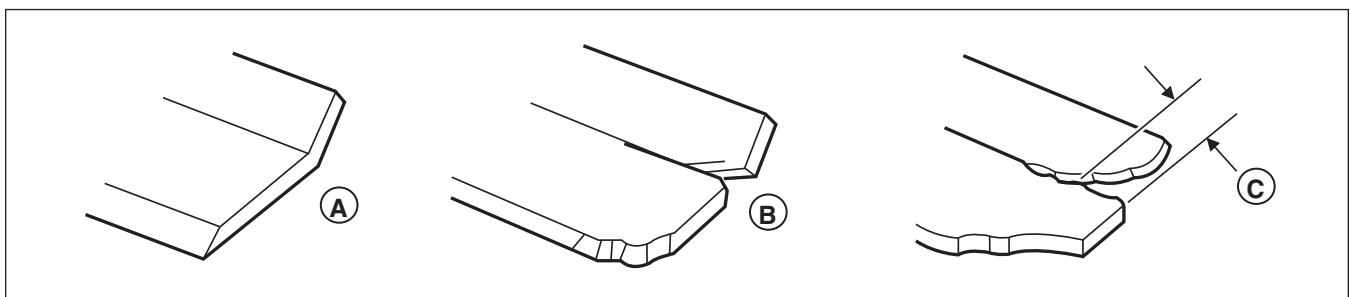



Figure 27. inspecting the Mower Blade Air Lifts

- A. New Mower Blade
- B. Mower Blade at Wear Limit (A notch begins to form)
- C. Mower Blade in Dangerous Condition (Notch measures .25" (6,35 mm) or greater **DO NOT USE**. Replace with new mower blade.)

Sharpening the Mower Blade

⚠ WARNING	
	Avoid injury! Mower blades are sharp.
<ul style="list-style-type: none"> • Always wear gloves when handling mower blades or working near blades. • Always wear safety eye protection when grinding. 	

1. Sharpen the mower blades with grinder, hand file, or electric blade sharpener.
2. Sharpen the mower blade by removing an equal amount of material from each end of the mower blade.
3. Keep the original bevel (**A**, **Figure 28**) when grinding. **DO NOT** change the mower blade bevel.
4. The mower blade should have a maximum 1/64" (0,40 mm) cutting edge (**B**) or less.
5. Balance the mower blades before installing.

Balancing the Mower Blades

⚠ WARNING	
	Avoid injury! Keep mower blades balanced.
<p>An unbalanced mower blade can create excessive vibration and damage the unit or cause mower blade failure.</p>	

1. Clean the mower blade to remove any dried grass or other debris.
2. See Figure 29. Put the mower blade on a nail in a vise and turn the mower blade to the horizontal position.
3. Check the balance of the mower blade. If either end of the mower blade moves downward, sharpen the heavy end until the mower blade is balanced. *See Sharpening the Mower Blades* for proper sharpening instructions.
4. Repeat the process until the mower blade remains in the horizontal position.

Reinstalling the Mower Blades

1. Wedge a wooden block between the mower blade and the mower deck housing to keep the mower blade from turning.
2. Reinstall each mower blade with the air lifts pointing up towards the mower deck as shown in Figure 30. Secure with the mower blade mounting bolt and flat washer (**A & B**, **Figure 30**) and torque to 70 ft. lbs (94 Nm).

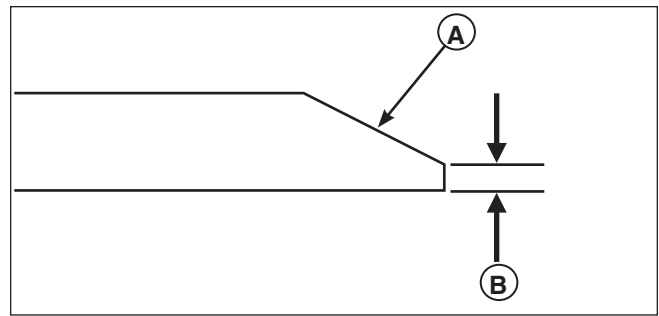

Figure 28. Sharpening the Mower Blade
 A. Mower Blade Bevel
 B. Mower Blade Cutting Edge

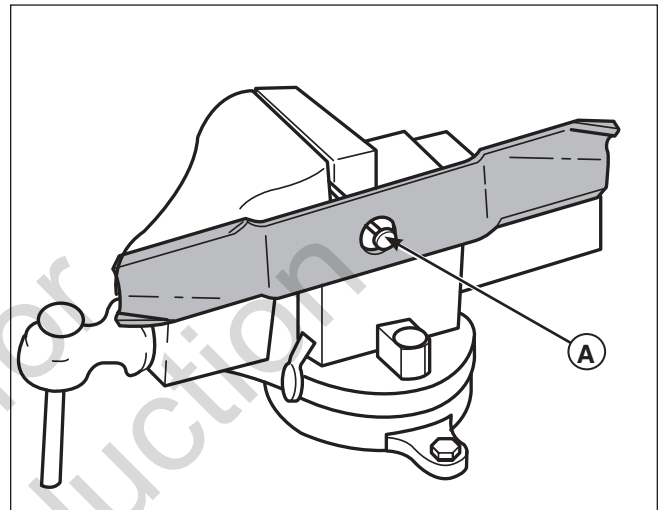

Figure 29. Balancing the Mower Blade
 A. Nail

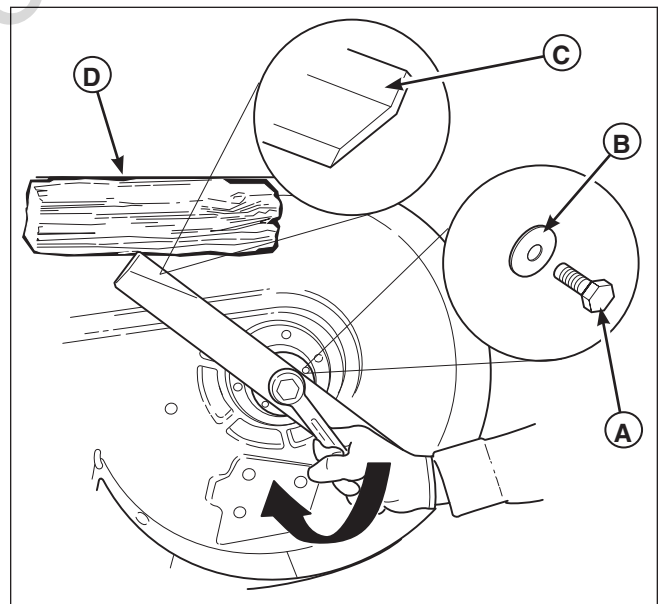

Figure 30. Tightening the Mower Blade for Installation
 A. Mower Blade Mounting Bolt
 B. Flat Washer
 C. Mower Blade Air Lift (Points Up For Installation)
 D. 4 X 4 Wooden Block

Ground Speed Control Lever Adjustment

The control levers can be adjusted in three ways. The alignment of the control levers, the placement of the levers (how close the ends are to one another) and the height of the levers can be adjusted.

To Adjust the Handle Alignment

Loosen the mount bolts (**A, Figure 31**) and pivot the lever(s) (**C**) to align with each other.

To Adjust the Handle Placement

Loosen the jam nuts and adjust the placement bolt (**B**) in or out to properly adjust the lever end spacing.

To Adjust the Handle Height

Remove the mounting hardware and reposition the handle either up or down from its original position. You will need to readjust the handle alignment as described above.

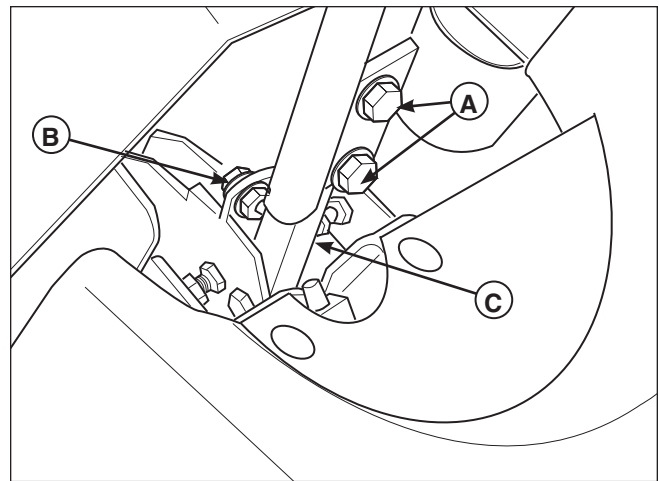

Figure 31. Control Lever Adjustment

- A. Alignment Hardware
- B. Placement Hardware
- C. Ground Speed Control Lever

Speed Balancing Adjustment

If the rider veers to the right or left when the ground speed control levers are in the maximum forward position, the top speed of each of these levers can be balanced by turning the adjustment bolt(s) (**A, Figure 32**). Only adjust the speed of the wheel that is traveling faster.

To Reduce the Speed of the Faster Wheel

1. Loosen the securing nut.
2. Turn the top speed adjustment bolt COUNTER-CLOCKWISE to reduce the speed.
3. Retighten the securing nut when adjustment is complete.

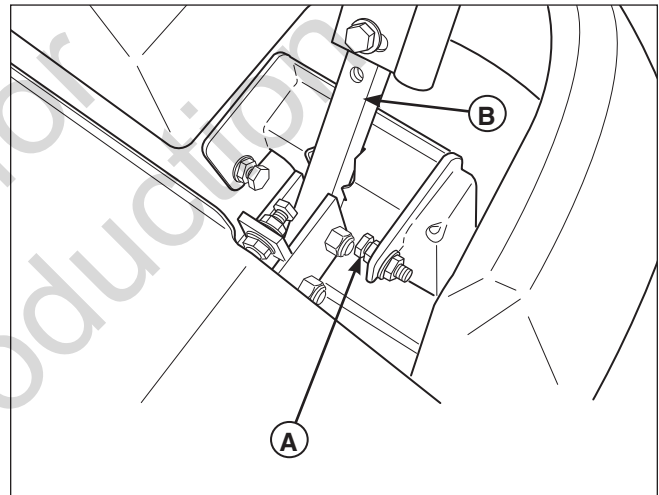

Figure 32. Top Speed Adjustment

- A. Top Speed Adjustment Bolt
- B. Control Lever Base

⚠ WARNING

Do NOT adjust the tractor for a faster overall speed forward or reverse than it was designed for.

Neutral Adjustment

If the tractor “creeps” while the ground speed control levers are locked in NEUTRAL, then it may be necessary to adjust the linkage rod.

NOTE: Perform this adjustment on a hard, level surface such as a concrete floor.

1. Disengage the PTO, engage the parking brake and turn off the engine.
2. The locking nuts (**D**, **Figure 33**) are to be used together to turn the rod. Loosen the jam nut that locks against the ball joint (**B**) and turn the linkage rod (**A**) to adjust. If the machine creeps forward, turn the rod CLOCKWISE (while standing at the rear of the machine, facing forward), if the machine creeps backward, turn the rod COUNTER-CLOCKWISE.
3. Lock the jam nut (**B**) against the ball joint (**C**) when neutral is achieved.

NOTE: This adjustment should not be performed while the machine is running. It may take several attempts to achieved neutral, depending upon how much the machine creeps.

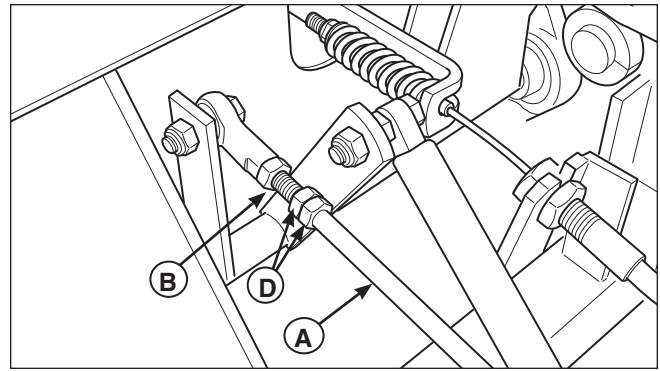

Figure 33. Neutral Adjustment (RH side shown)

- A. Adjustment Linkage Rod
- B. Jam Nut
- C. Ball Joint
- D. Locking Nuts

Return-to-Neutral Adjustment

To determine if it is necessary to adjust the neutral return, perform the following steps.

1. Disengage the PTO, engage the parking brake and turn off the engine.
2. Move the ground speed control levers into the operating position, pull levers rearward and release.
3. Move the ground speed control levers out towards the neutral position. If the levers do not align with the notches in the neutral lock plate, it is necessary to adjust the neutral return rod.

To Adjust:

1. Lock the ground speed control lever in the neutral position.
2. Measure the length of the neutral return spring (**C**, **Figure 34**) it should be set at 3.25” (8,23cm). If the spring does not measure 3.25” (8,23cm) loosen the front set collar (**D**) and the rear set collar (**A**), then move the front set collar forward or back on the neutral return rod (**B**) until the spring length equals 3.25” (8,23cm). Retighten the front set collar.
3. Make sure that the neutral return bushing (**E**) is seated correctly in the spring stop plate (**F**).
4. Position the rear set collar so that it sets tightly against neutral return bushing and tighten.
5. Pull the ground speed control lever rearward and release to check position again. Adjust as necessary to align the ground speed control levers with the notches in the neutral lock plate.

It is important to note that after every adjustment of the neutral return rod, the lever must be pulled rearward and released to properly check the neutral position.

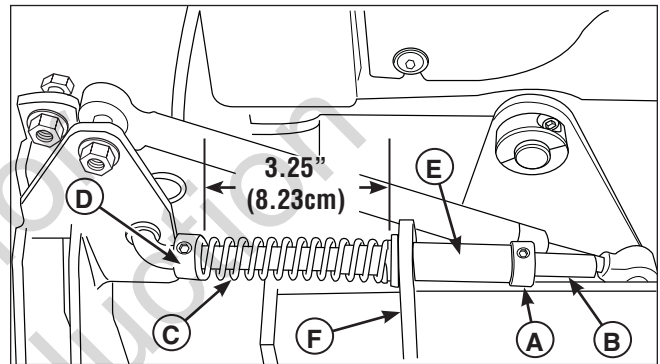

Figure 34. Neutral Return Spring Adjustment

- A. Rear Set Collar
- B. Neutral Return Rod
- C. Neutral Return Spring
- D. Front Set Collar
- E. Neutral Return Bushing
- F. Spring Stop Plate

Parking Brake Adjustment

1. Disengage the PTO, engage the parking brake, stop the engine and remove the ignition key.
2. Raise the seat plate.
3. Locate the brake spring (**A**, **Figure 35**).
4. With the parking brake engaged, measure the compressed spring length. The spring should be $1\frac{15}{16}'' - 2''$ (4,9 - 5,1 cm) when compressed.
5. If the spring is not within this range, release the parking brake and turn the adjustment nut (**B**) to compress or relax the spring.
6. Engage the parking brake and remeasure the spring

NOTICE

Do NOT adjust the spring shorter than $1\frac{15}{16}''$ (4,9 cm) when compressed. This may damage the brake mechanism.

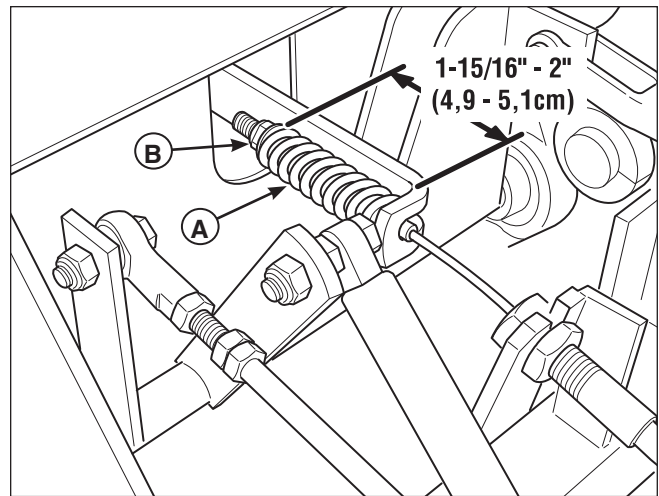

Figure 35. Parking Brake Adjustment

- A. Brake Spring
B. Adjustment Nut

Hydraulic Pump Drive Belt Replacement

1. Park the tractor on a smooth, level surface such as a concrete floor. Disengage the PTO, engage the parking brake, turn off the engine, and remove the ignition key.
2. Remove the PTO drive belt (see MOWER BELT REPLACEMENT for removal instructions).
3. Remove the hardware that secures the clutch anchor pad to the PTO clutch.
4. Loosen the nut towards the front of the machine on the spring anchor hook (**G**, **Figure 36**) to release the majority of the belt tension. Use caution and remove the nut to completely release the tension.
5. Remove the old belts and replace it with the new ones. Make sure the V-side of the belt runs in the grooves of the crankshaft pulley and pump pulleys (**B & C**).
6. Reinstall the anchor hook (**G**) into the anchor tab and loosely fasten the nut. Adjust the anchor hook until a measurement of $8\frac{3}{8}''$ (21,2 cm) is achieved from the outside of the spring hooks. Tighten nut.
7. Reinstall the clutch anchor pad to the PTO clutch and secure with the hardware previously removed.
8. Reinstall the PTO drive belt.

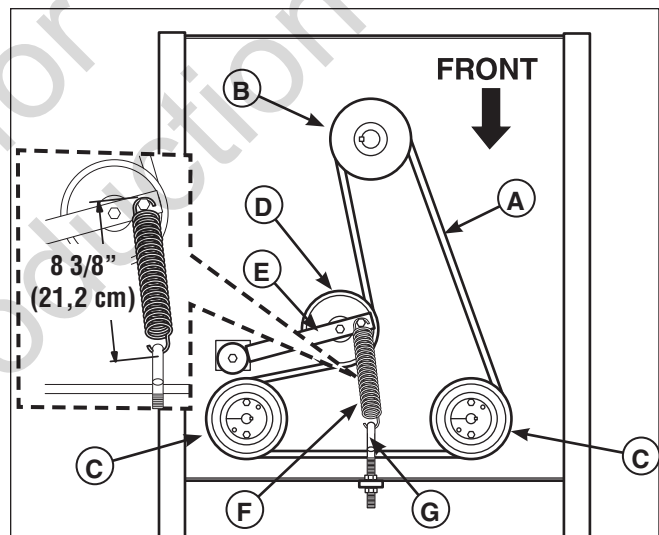

Figure 36. Hydraulic Pump Drive Belt Replacement

- A. Pump Drive Belt
B. Crankshaft Pulley
C. Pump Pulley
D. Idler Pulley
E. Idler Arm
F. Spring
G. Spring Anchor Hook

Rear Suspension Adjustment

The shock assembly can be adjusted to allow the operator to customize the ride according to operator's weight and/or operating conditions. You have the option of adjusting the spring pre-load.

Items to consider before adjusting the suspension.

- Less spring pre-load should be used with light weight operators, which will provide a softer, more cushioned ride.
- More spring pre-load should be used with heavy weight operators, or when a rear-mount grass bagger system is installed, which will provide a stiffer, more rigid ride.

To adjust the spring pre-load:

1. Park machine on a flat, level surface. Disengage the PTO, stop the engine and engage the parking brake.
2. Raise the rear of the machine and secure with jackstands. Chock the front wheels to prevent the machine from rolling.
3. Remove the rear drive tires.
4. See Figure 37. Using the supplied spanner wrench (p/n 5022853), insert the tip of the wrench into the notch in the pre-load adjuster. While holding the wrench in place with one hand, turn COUNTER-CLOCKWISE to increase the pre-load, turn CLOCKWISE to decrease the pre-load. Make sure both shocks are set to the same amount of pre-load.
5. Reinstall the rear drive tires. Torque the lug bolts to 85-95 ft/lbs. (115-129 Nm). Remove the jackstands from under the machine.

NOTE: Spanner wrench is located under the seat on the right-hand side of the machine.

NOTE: It is recommended that the rear suspension be adjusted stiffer due to the added weight of the collection system.

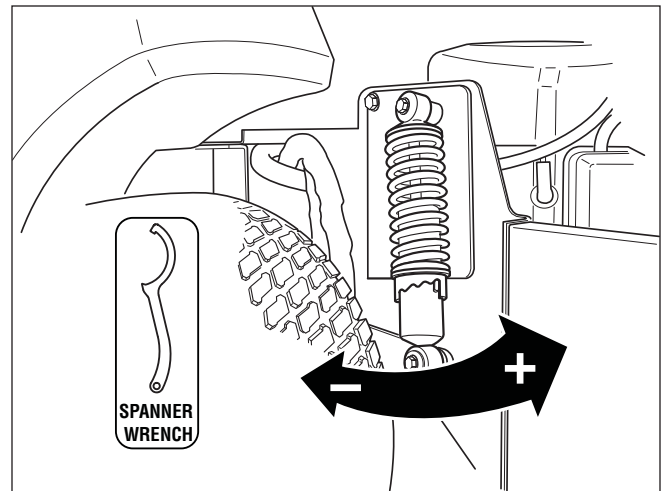



Figure 37. Rear Suspension Adjustments

⚠ WARNING	
	Spring loaded components can kick back causing injury.
Use two hands when adjusting the shock assemblies. This will prevent the wrench from slipping while pressure is being applied.	

Deck Lift Rod Timing And Leveling Adjustment

1. Park machine on a flat, level surface. Disengage the PTO, stop the engine and engage the parking brake. Rear tires must be inflated to 15 psi (1,03 bar); front tires to 40 psi (2,76 bar).
 2. To check the lift rod timing, measure and record the distance between the lift pivots and the rod pivots. Repeat for other side of unit. See Figure 38.
 3. If the measurements are equal, skip to Step 5. If the measurements are NOT equal (greater than 1/8" (3,17mm) difference), adjustment is required, continue with Step 4.
 4. Refer to Figure 39. To adjust the lift rod timing, adjust the 5/8" hex nuts on either side of the front lift pivot until the measurements are equal. Repeat for other side.
 5. Place the deck height adjustment pin in the 4" (10,2 cm) position.
- 44" Models: All; 48" Models: S/N: 2014720668 & Below:**
6. Refer to Figure 40. Place 2 x 4 blocks under each corner of the mower deck with the 3-1/2" sides being vertical. Place a 1/4" (0,64 cm) thick spacer on top of the rear 2 x 4 blocks.
 7. Adjust the front eyebolts until the chains are tight and the deck is still resting on the 2 x 4's. Tighten jam nuts. See Figure 41.
 8. Loosen the nuts and allow the rear of the deck to rest on the 2 x 4's and 1/4" spacers. Slide the chains in the slots until the chains are tight and tighten the nuts. See Figure 41.
 9. Remove all 2 x 4 blocks and spacers from under the mower deck.
- 48" Models: S/N: 2014720669 & Above:**
6. Refer to Figure 40. Place 2 x 4 blocks under each corner of the mower deck with the 3-1/2" sides being vertical.
 7. Adjust the front eyebolts until the chains are tight and the deck is still resting on the 2 x 4's. Tighten jam nuts. See Figure 41.
 8. Loosen the nuts and allow the rear of the deck to rest on the 2 x 4's. Slide the chains in the slots until the chains are tight and tighten the nuts. See Figure 41.
 9. Remove all 2 x 4 blocks from under the mower deck.

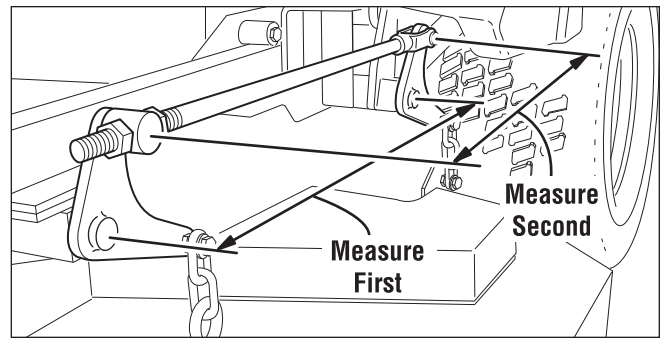

Figure 38. Check Lift Rod Timing

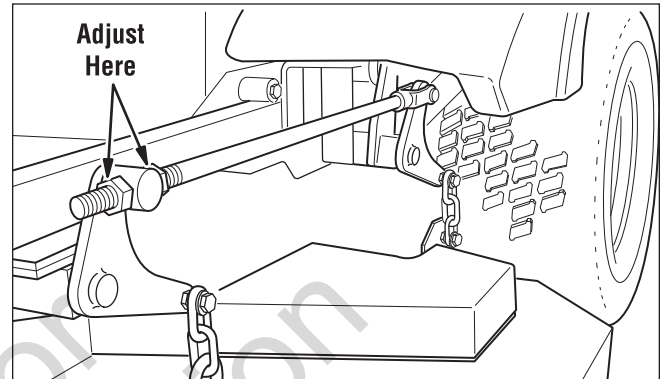

Figure 39. Adjust Lift Rod Timing

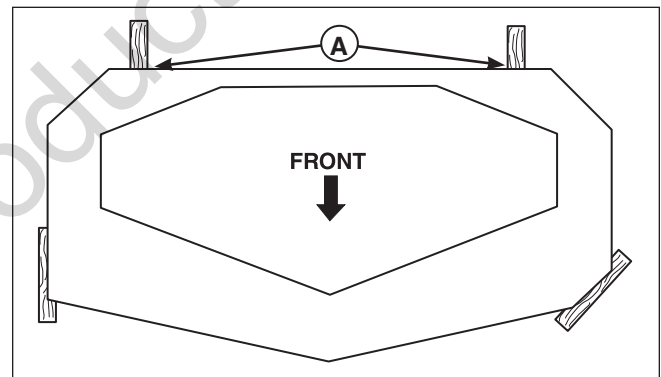

Figure 40. 2 x 4 Locations
A. 1/4" Spacers

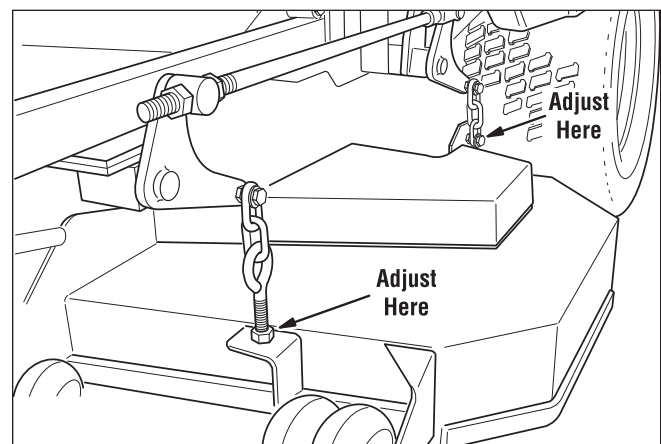

Figure 41. Hanger Chain Adjustment

Mower Belt Replacement

NOTICE

To avoid damaging belts, do NOT pry belts over pulleys.

1. Park the tractor on a smooth, level surface such as a concrete floor. Disengage the PTO, engage the parking brake, turn off the engine, and remove the ignition key.
2. Lower the mower deck to its lowest cutting position and remove the mower deck guards.

WARNING



Spring loaded components can kick back causing injury.

Use extreme caution when rotating the idler arm with the breaker bar, due to the increased tension in the spring as the idler arm is being rotated. Injury may result in the breaker bar is prematurely release while the spring is under tension.

3. Using a 1/2" breaker bar, place the square end in the square hole located in the end of the idler arm (A, **Figure 42**). Carefully rotate the breaker bar clockwise, which will relieve the tension on the belt exerted from the idler arm.
4. Slide the drive belt over the edge of the stationary idler pulley (B). Carefully release the tension on the breaker bar.
5. Remove the old belt and replace with a new one. Make sure the V-side of the belt runs in the pulley grooves (**Figure 43**).
6. Install the drive belt on the PTO pulley, the spindle pulleys and all idler pulleys except the stationary pulley (B, **Figure 43**). Carefully rotate the breaker bar clockwise and install the belt on the stationary idler pulley (B). Carefully release the tension on the breaker bar.
7. Reinstall the mower deck guards.
8. Run the mower under no-load condition for about 5 minutes to break-in the new belt.

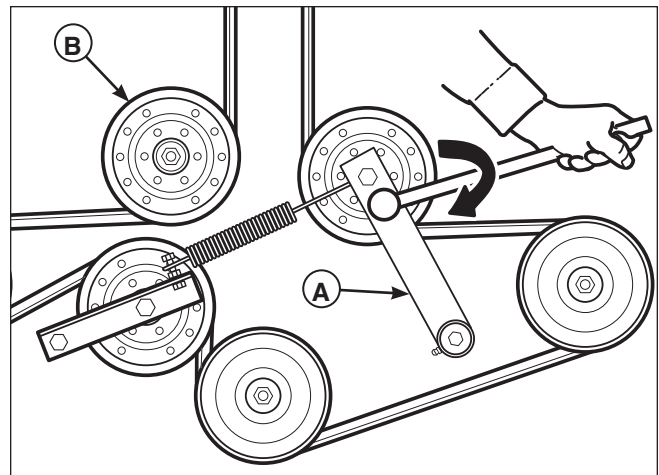

Figure 42. Mower PTO Belt

- A. Idler Arm
- B. Stationary Idler Pulley

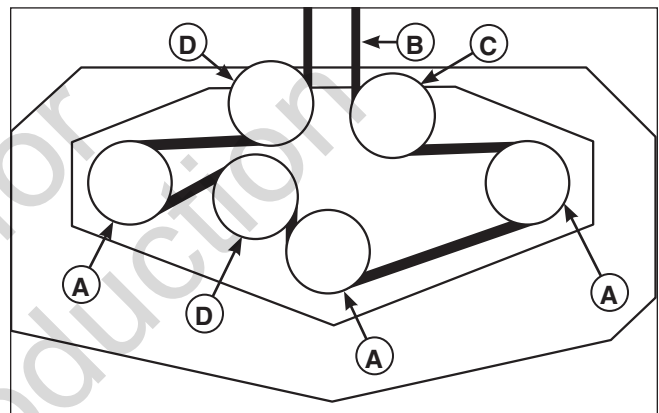

Figure 43. Mower PTO Belt Routing

- A. Spindle Pulley
- B. PTO Drive Belt
- C. Spring-loaded Idler Pulley
- D. Stationary Idler Pulley

Check the Mower Belt Tensioner Spring Length - 44" Models (All) & 48" Models (S/N: 2014720668 & Below)

With the spring anchor (A, Figure 44) adjusted in the second hole (B) of the spring bracket (C) the coil-to-coil spring length should measure 7-1/4" (18,42 cm).

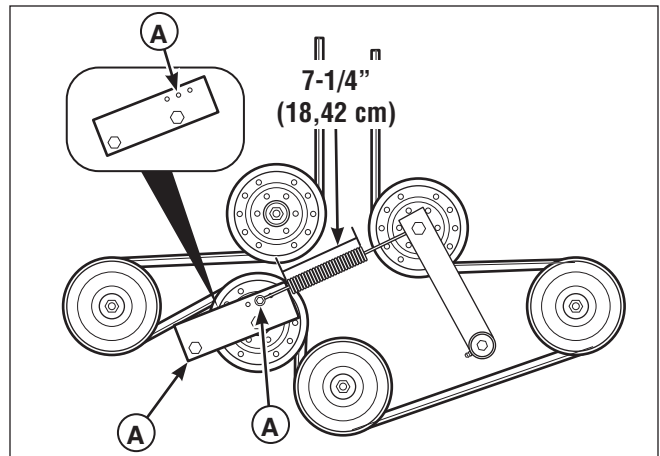

Figure 44. Check the Mower Belt Tensioner Spring Length
 A. Spring Anchor
 B. Second Hole
 C. Spring Bracket

Check the Mower Belt Idler Tensioner Spring Length - 48" Models (S/N: 2014720669 & Above)

1. Park the machine on a smooth level surface such as a concrete floor. Disengage the PTO, engage the parking brake, turn off the engine and remove the ignition key.
2. Lower the mower deck to its lowest cutting position.
3. Measure the coil length of the mower belt tensioner spring (A, Figure 45). The measurement should equal 7-1/4" (18,42 cm). If the measurement does not equal 7-1/4" (18,42 cm), adjust the anchor eyebolt (B).

Adjusting the Mower Belt Idler Spring Length - 48" Models (S/N: 2014720669 & Above)

1. Loosen the jam nut (C).
2. Turn the adjustment nut (D) until a measurement of 7-1/4" (18,42 cm) is achieved.
3. Retighten the jam nut.

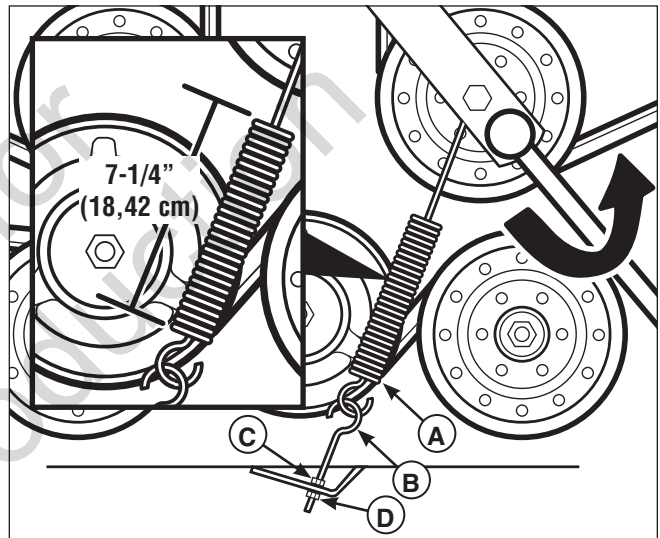



Figure 45. Mower Belt Idler Spring Length
 A. Mower Belt Tensioner Spring
 B. Anchor Eyebolt
 C. Jam Nut
 D. Adjustment Nut

Troubleshooting

While normal care and regular maintenance will extend the life of your equipment, prolonged or constant use may eventually require that service be performed to allow it to continue operating properly.

The troubleshooting guide below lists the most common problems, their causes and remedies.

See the information on the following pages for instructions on how to perform most of these minor adjustments and service repairs yourself. If you prefer, all of these procedures can be performed for you by your local authorized dealer.

⚠ WARNING	
	Remove the ignition key prior to performing maintenance on the unit.
<ul style="list-style-type: none"> To avoid serious injury, perform maintenance on the tractor or mower only when the engine is stopped and the parking brake is engaged. Always remove the ignition key, disconnect the spark plug wire and fasten it away from the plug before beginning the maintenance, to prevent accidental starting of the engine. 	

Troubleshooting the Rider		
PROBLEM	CAUSE	REMEDY
Engine will not turnover or start.	<ol style="list-style-type: none"> Parking brake not engaged. PTO (electric clutch) switch in ON position. Out of fuel Engine flooded. Fuse blown. Battery terminals require cleaning. Battery discharged or dead. Wiring loose or broken. Solenoid or starter motor faulty. Safety interlock switch faulty. Spark plug(s) faulty, fouled or incorrectly gapped. Water in fuel. Gas is old or stale. 	<ol style="list-style-type: none"> Engage parking brake. Place in OFF position. If engine is hot allow to cool, then refill the fuel tank. Move choke control to CLOSED position. Replace fuse. Clean the battery terminals. Recharge or replace. Visually check wiring & replace broken or frayed wires. Tighten loose connections. Repair or replace. See authorized dealer. Replace as needed. See authorized service dealer. Clean and gap or replace. See engine manual. Drain fuel & replace with fresh fuel. Drain fuel & replace with fresh fuel.
Engine starts hard or runs poorly.	<ol style="list-style-type: none"> Fuel mixture too rich. Spark plug(s) faulty, fouled, or incorrectly gapped. 	<ol style="list-style-type: none"> Clean air filter. Check choke adjustment. Clean and gap or replace. See engine manual.
Engine knocks	<ol style="list-style-type: none"> Low oil level. Using wrong grade oil. 	<ol style="list-style-type: none"> Check/add oil as required. See engine manual.
Excessive oil consumption	<ol style="list-style-type: none"> Engine running too hot. Using wrong weight oil. Too much oil in crankcase. 	<ol style="list-style-type: none"> Clean engine fins, blower screen and air cleaner. See engine manual. Drain excess oil.
Engine exhaust is black.	<ol style="list-style-type: none"> Dirty air filter. Engine choke control is in CLOSED position. 	<ol style="list-style-type: none"> Replace air filter. See engine manual. Open choke control.

Troubleshooting the Rider continued		
PROBLEM	CAUSE	REMEDY
Engine runs, but rider will not drive.	<ol style="list-style-type: none"> 1. Hydraulic release valve(s) in "open" position. 2. Belt is broken. 3. Drive belt slips. 4. Brake is not fully released. 	<ol style="list-style-type: none"> 1. Turn hydraulic release valve(s) CLOCKWISE to close. 2. See Drive Belt Replacement. 3. See Problem and Cause below. 4. See authorized service dealer.
Rider drive belt slips.	<ol style="list-style-type: none"> 1. Pulleys or belt greasy or oily. 2. Tension too loose. 3. Belt stretched or worn. 	<ol style="list-style-type: none"> 1. Clean as required. 2. Adjust spring tension. See Drive Belt Replacement. 3. Replace belt.
Brake will not hold.	<ol style="list-style-type: none"> 1. Brake is incorrectly adjusted. 2. Brake pads worn. 	<ol style="list-style-type: none"> 1. See Brake Adjustment. 2. Replace with new brake pads.
Rider steers or handles poorly.	<ol style="list-style-type: none"> 1. Steering linkage is loose. 2. Improper tire inflation. 	<ol style="list-style-type: none"> 1. Check and tighten any loose connections. 2. See Operation section.
Troubleshooting the Mower		
PROBLEM	CAUSE	REMEDY
Mower will not raise.	<ol style="list-style-type: none"> 1. Lift linkage not properly attached or damaged. 	<ol style="list-style-type: none"> 1. See authorized service dealer for repair.
Engine stalls easily with mower engaged.	<ol style="list-style-type: none"> 1. Engine speed too slow. 2. Ground speed too fast. 3. Cutting height set too low. 4. Discharge chute jamming with cut grass. 	<ol style="list-style-type: none"> 1. Set to full throttle. 2. Decrease ground speed. 3. Cut tall grass at maximum cutting height during first pass. 4. Cut grass with discharge pointing towards previously cut area.
Excessive mower vibration.	<ol style="list-style-type: none"> 1. Blade mounting bolts are loose. 2. Mower blades, spindles or pulleys are bent. 3. Mower blades are out of balance. 4. Belt installed incorrectly. 	<ol style="list-style-type: none"> 1. Tighten to 70 ft.lbs (94 Nm) 2. Check and replace as necessary. 3. Remove, sharpen and balance blades. See Maintenance section. 4. Reinstall correctly.
Excessive belt wear or breakage.	<ol style="list-style-type: none"> 1. Bent or rough pulleys. 2. Using incorrect belt. 	<ol style="list-style-type: none"> 1. Repair or replace. 2. Replace with correct belt.
Mower drive belt slips or fails to drive.	<ol style="list-style-type: none"> 1. Idler pulley spring broken or not properly attached. 2. Mower drive belt broken. 	<ol style="list-style-type: none"> 1. Repair or replace as needed. 2. Replace drive belt.
Mower does not engage.	<ol style="list-style-type: none"> 1. Electrical wiring damage. 2. Battery voltage too low. 	<ol style="list-style-type: none"> 1. Locate and repair damaged wire. 2. Recharge battery and check alternator. See Battery Maintenance section.

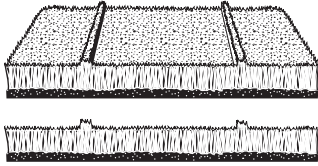
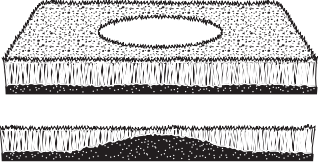
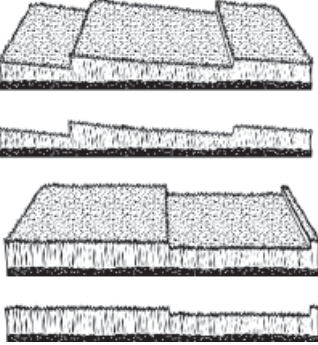
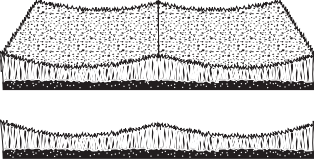
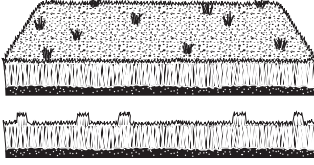
Troubleshooting Common Cutting Problems		
PROBLEM	CAUSE	REMEDY
Streaking		
	<ol style="list-style-type: none"> 1. Blades are not sharp. 2. Blades are worn down too far. 3. Engine speed is too slow. 4. Ground speed is too fast. 5. Deck is plugged with grass. 6. Not overlapping cutting rows enough. 7. Not overlapping enough when turning. 	<ol style="list-style-type: none"> 1. Sharpen your blades. 2. Replace your blades. 3. Always mow at FULL throttle. 4. Slow down. 5. Clean out the mower. 6. Overlap your cutting rows. 7. When turning your effective cutting width decreases—overlap more when turning.
Scalping		
	<ol style="list-style-type: none"> 1. Lawn is uneven or bumpy. 2. Mower deck cutting height is set too low. 3. Ground speed is too fast. 4. Deck is not levelled correctly. 5. Tire pressure is low or uneven. 	<ol style="list-style-type: none"> 1. Roll or level the lawn. 2. Raise the cutting height. 3. Slow down. 4. Correctly level the deck. 5. Check and inflate the tires.
Stepped Cutting.		
	<ol style="list-style-type: none"> 1. Deck is not leveled correctly. 2. Tires are not properly inflated. 3. Blades are damaged. 4. Deck shell is damaged. 5. Mower spindle is bent or loose. 6. Blades are installed incorrectly. 	<ol style="list-style-type: none"> 1. Level the deck correctly. 2. Check and inflate the tires. 3. Replace the blades. 4. Repair or replace the deck. 5. Repair or replace the spindle. 6. Reinstall the blades correctly.
Uneven Cutting		
	<ol style="list-style-type: none"> 1. Deck is not leveled correctly. 2. Blades are dull or worn. 3. Blades are damaged. 4. Deck is clogged with grass clippings. 5. Deck shell is damaged. 6. Mower spindle is bent or loose. 7. Blades are installed incorrectly. 8. Tires are not properly inflated. 	<ol style="list-style-type: none"> 1. Level the deck correctly. 2. Sharpen or replace the blades. 3. Replace the blades. 4. Clean out the deck. 5. Repair or replace the deck. 6. Repair or replace the spindle. 7. Reinstall the blades correctly. 8. Check and inflate the tires.
Stingers		
	<ol style="list-style-type: none"> 1. Blades are not sharp or nicked. 2. Blades are worn down too far. 3. Engine speed is too low. 4. Ground speed is too fast. 5. Deck is plugged with grass. 	<ol style="list-style-type: none"> 1. Sharpen your blades. 2. Replace your blades. 3. Always mow at full throttle. 4. Slow down. 5. Clean out the mower.

Specifications

Specifications are correct at time of printing and are subject to change without notice.

ENGINE:

24 Gross HP* Briggs & Stratton

Make	Briggs & Stratton
Model	44M777-0113-E1 (S/N: 2013156319 & Below) 44M777-0133-G1 (S/N: 2013156320 & Above)
Displacement	44.18 Cu. in (724 cc)
Electrical System	12 Volt, 16 amp. Alternator, Battery: 340 CCA
Oil Capacity	2 qt. (1.89 L) w/ Filter

26 Gross HP* Briggs & Stratton

Make	Briggs & Stratton
Model	44P777-0124-G1 (S/N: 2013156319 & Below) 44P777-0135-G1 (S/N: 2013156320 & Above)
Displacement	44.18 Cu. in (724 cc)
Electrical System	12 Volt, 16 amp. Alternator, Battery: 340 CCA
Oil Capacity	2 qt. (1.89 L) w/ Filter

27 Gross HP* Briggs & Stratton

Make	Briggs & Stratton
Model	44Q777-0146-G1
Displacement	44.18 Cu. in (724 cc)
Electrical System	12 Volt, 16 amp. Alternator, Battery: 340 CCA
Oil Capacity	2 qt. (1.89 L) w/ Filter

CHASSIS:

Fuel Tank	Capacity: 6 Gallons (22.7 L) Total
Rear Wheels	Tire Size: 20 x 8.00 -10 Inflation Pressure: 15 psi (1,03 bar)
Front Wheels	Tire Size: 11 x 4.00 - 5 Inflation Pressure: 40 psi (2,76 bar)

***Power Ratings:** The gross power rating for individual gas engine models is labeled in accordance with SAE (Society of Automotive Engineers) code J1940 (Small Engine Power & Torque Rating Procedure), and rating performance has been obtained and corrected in accordance with SAE J1995 (Revision 2002-05). Torque values are derived at 3060 RPM; horsepower values are derived at 3600 RPM. The gross power curves can be viewed at www.BRIGGSandSTRATTON.COM. Net power values are taken with exhaust and air cleaner installed whereas gross power values are collected without these attachments. Actual gross engine power will be higher than net engine power and is affected by, among other things, ambient operating conditions and engine-to-engine variability. Given the wide array of products on which engines are placed, the gas engine may not develop the rated gross power when used in a given piece of power equipment. This difference is due to a variety of factors including, but not limited to, the variety of engine components (air cleaner, exhaust, charging, cooling, carburetor, fuel pump, etc.), application limitations, ambient operating conditions (temperature, humidity, altitude), and engine-to-engine variability. Due to manufacturing and capacity limitations, Briggs & Stratton may substitute an engine of higher rated power for this Series engine.

TRANSMISSIONS:

S/N: 2012670667 & Below:

LH	PG-1HQQ-DV1X-XXXX (5100072) HGM-12C-4025 (5023316)
RH	PG-1KQQ-DV1X-XXXX (5100073) HGM-12C-4025 (5023316)

2012670668 - 2013259904

LH	PE-1HQQ-DV1X-XXXX (5101403) HGM-12C-4025 (5023316)
RH	PE-1KQQ-DV1X-XXXX (5101404) HGM-12C-4025 (5023316)

2013259905 - 2014454549

LH	PE-1HQQ-DV1X-XXXX (5101403) TF0195LS080AAKZ (5102728)
RH	PE-1KQQ-DV1X-XXXX (5101404) TF0195LS081AAKZ (5102729)

2014454550 & Above

LH	PE-1HQQ-DV1X-XXXX (5101403) TL0195LS080AAKZ (5102184)
RH	PE-1KQQ-DV1X-XXXX (5101404) TL0195LS081AAKZ (5102185)

Type	Pump and Wheel Motor
Hydraulic Fluid	SAE 20W-50 motor oil
Speeds	Forward: 0-8 MPH (0-12.88 km/h)
@ 3400 rpm	Reverse: 0-4 MPH (0-6.44 km/h)
Continuous Torque Output	222 ft. lbs. (301 Nm)
Maximum Weight on Axle	750 lbs. (340 Kg)

DIMENSIONS:

Overall Length	79" (201 cm)
Overall Width	61" (155 cm)
Height	65" (165 cm)
Weight (apx..)	945 lbs. (429 kg)

SLOPE IDENTIFICATION GUIDE

1 FOLD ALONG APPROPRIATE DOTTED LINE

THIS IS A 15 DEGREE SLOPE
THIS IS A 10 DEGREE SLOPE

ALIGN THIS EDGE WITH A VERTICAL SURFACE
(TREE, POLE, FENCE POST, BUILDING, ETC)

2

3 COMPARE THE ANGLE OF THE FOLD TO THE ANGLE OF THE SLOPE

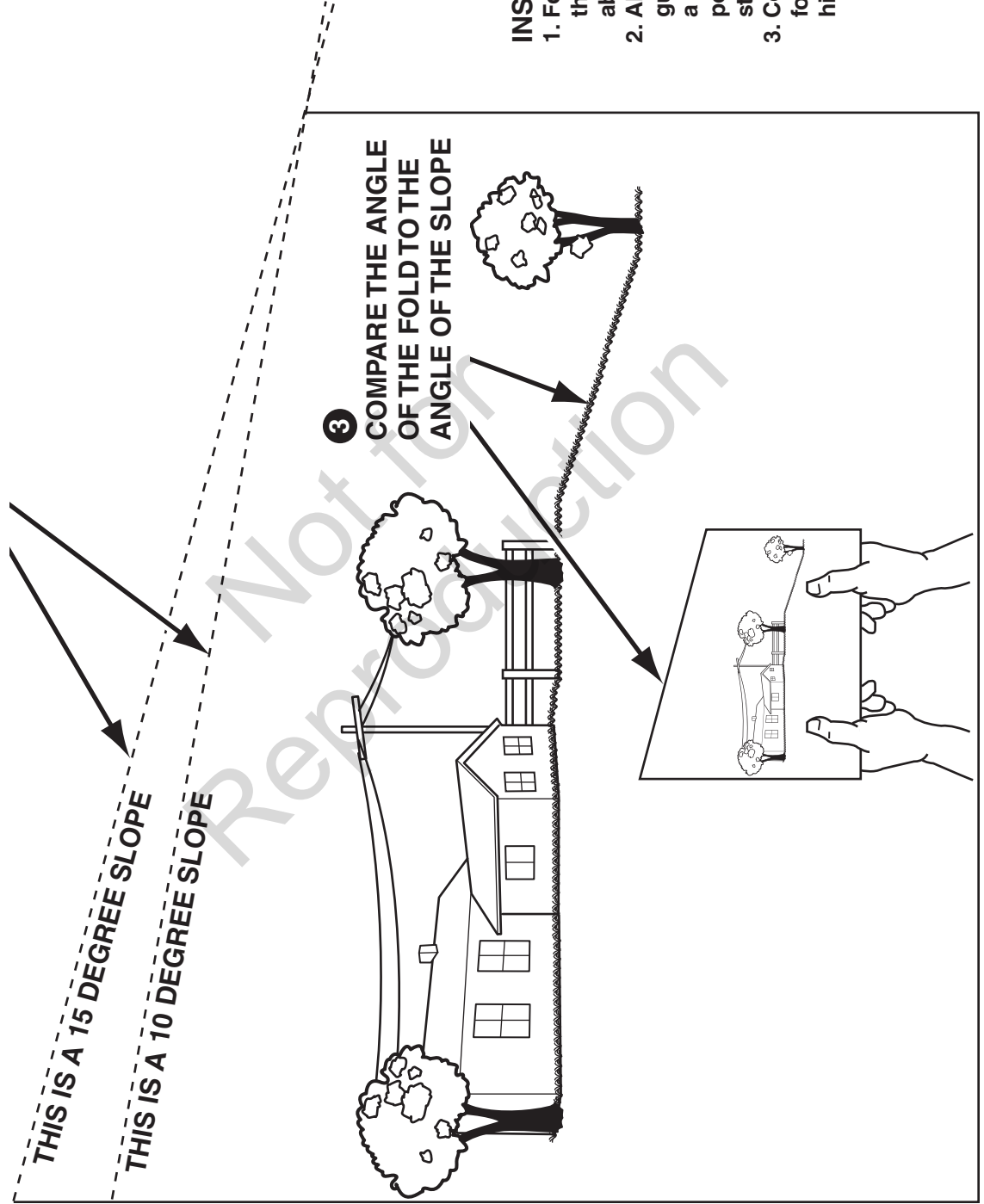

INSTRUCTIONS

1. Fold this page along the dotted line indicated above.
2. Align the left edge of this guide with a vertical tree, a power line pole, a fence post, or any vertical structure.
3. Compare the angle of the fold with the angle of the hill.

Notes

Not for
Reproduction

Notes

Not for
Reproduction

LIMITED WARRANTY

Briggs & Stratton Power Products Group, LLC will repair and/or replace, free of charge, any part(s) of the equipment that is defective in material or workmanship or both. Briggs & Stratton Corporation will repair and/or replace, free of charge, any part(s) of the Briggs and Stratton engine* (if equipped) that is defective in material or workmanship or both. Transportation charges on product submitted for repair or replacement under this warranty must be borne by purchaser. This warranty is effective for the time periods and subject to the conditions stated below. For warranty service, find the nearest Authorized Service Dealer using our dealer locator at www.Simplicitymfg.com.

There is no other express warranty. Implied warranties, including those of merchantability and fitness for a particular purpose, are limited to one year from purchase or to the extent permitted by law. Liability for incidental or consequential damages are excluded to the extent exclusion is permitted by law.

Some states or countries do not allow limitations on how long an implied warranty lasts, and some states or countries do not allow the exclusion or limitation of incidental or consequential damages, so the above limitation and exclusion may not apply to you. This warranty gives you specific legal rights and you may also have other rights which vary from state to state or country to country.

WARRANTY PERIOD

<u>Item</u>	<u>Consumer Use</u>	<u>Commercial Use:</u>
Equipment	2 Years	90 Days
Engine*	2 Years	1 Year
Battery	1 Year	1 Year

The warranty period begins on the date of purchase by the first retail consumer or commercial end user, and continues for the period of time stated above. "Consumer use" means personal residential household use by a retail consumer. "Commercial use" means all other uses, including use for commercial, income producing or rental purposes. Once product has experienced commercial use, it shall thereafter be considered as commercial use for purposes of this warranty.

No warranty registration is necessary to obtain warranty on Briggs & Stratton products. Save your proof of purchase receipt. If you do not provide proof of the initial purchase date at the time warranty service is requested, the manufacturing date of the product will be used to determine warranty eligibility.

ABOUT YOUR WARRANTY

We welcome warranty repair and apologize to you for being inconvenienced. Warranty service is available only through servicing dealers authorized by Briggs & Stratton or BSPPG, LLC.

Most warranty repairs are handled routinely, but sometimes requests for warranty service may not be appropriate. This warranty only covers defects in materials or workmanship. It does not cover damage caused by improper use or abuse, improper maintenance or repair, normal wear and tear, or stale or unapproved fuel.

Improper Use and Abuse - The proper, intended use of this product is described in the Operator's Manual. Using the product in a way not described in the Operator's Manual or using the product after it has been damaged will void your warranty. Warranty is not allowed if the serial number on the product has been removed or the product has been altered or modified in any way, or if the product has evidence of abuse such as impact damage, or water/chemical corrosion damage.

Improper Maintenance or Repair - This product must be maintained according to the procedures and schedules provided in the Operator's Manual, and serviced or repaired using genuine Briggs & Stratton parts. Damage caused by lack of maintenance or use of non-original parts is not covered by warranty.

Normal Wear - Like all mechanical devices, your unit is subject to wear even when properly maintained. This warranty does not cover repairs when normal use has exhausted the life of a part or the equipment. Maintenance and wear items such as filters, belts, cutting blades, and brake pads (engine brake pads are covered) are not covered by warranty due to wear characteristics alone, unless the cause is due to defects in material or workmanship.

Stale Fuel - In order to function correctly, this product requires fresh fuel that conforms to the criteria specified in the Operator's Manual. Damage caused by stale fuel (carburetor leaks, clogged fuel tubes, sticking valves, etc) is not covered by warranty.

* Applies to Briggs and Stratton engines only. Warranty coverage of non-Briggs and Stratton engines is provided by the engine manufacturer.



Not for
Reproduction



MANUFACTURING, INC.
PO Box 702
Milwaukee, WI, 53201-0702
1-800-837-6836
www.simplicitymfg.com