

**NEW  
PRODUCT**

## TF TRANQUIL BATHROOM FANS

Continental Fan's TF Tranquil Bathroom Fans are available in non-lighted and lighted versions, suitable for all interiors. The built-in damper prevents a backdraft, keeping tempered air in a home when the fan is not operating.



TF & TF-L Tranquil Bathroom Fans

### Design Features

- Superior ventilation & efficient performance
- Whisper-quiet, under 1 sone
- Non-lighted (TF80 & TF110) & lighted (TF80L & TF110L) versions
- Clean, simple grille design
- Galvanized steel housing
- Easy installation
- Double hanger mounting brackets adjust up to 24" span
- Built-in backdraft damper
- Efficient AC motor
- 120V, 60 Hz operation
- Automatic reset thermal overload protection
- Max 26W GU24 fluorescent light
- Available to fit duct sizes 4" & 6"
- TF110 & TF110L are HVI certified and Energy Star qualified for 6" duct only



ETL In Process

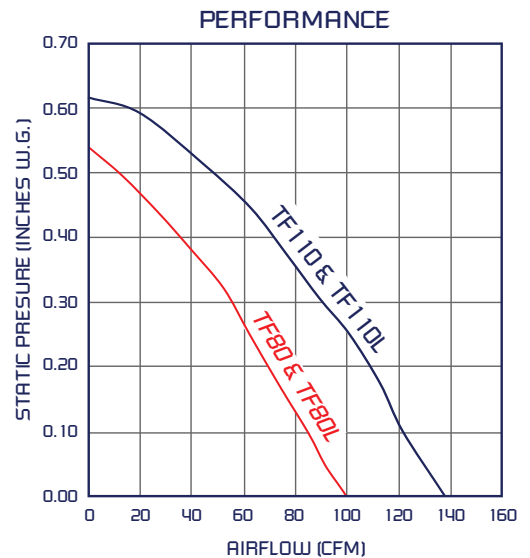
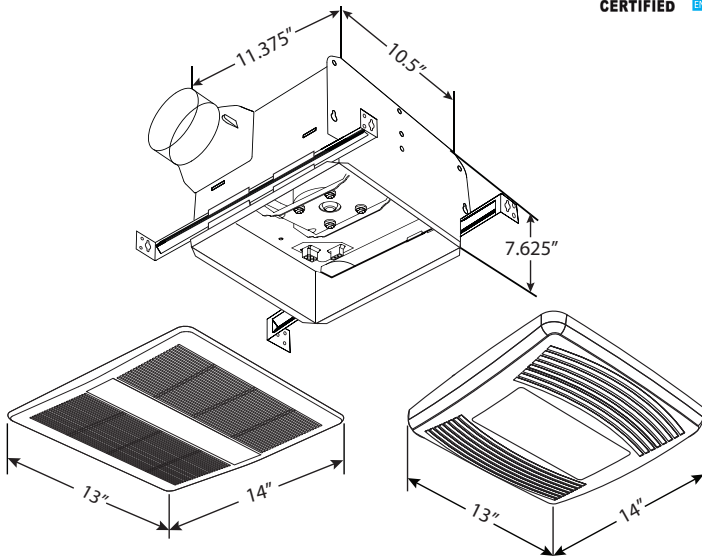

Model	NON-LIGHTED FANS		LIGHTED FANS	
	TF80	TF110	TF80L	TF110L
Air Volume (cfm @ 0.1" SP)	80	110	80	110
Air Volume (cfm @ 0.25" SP)	58	100	58	100
Noise (Sones)	0.4	0.9	0.4	0.9
Power Consumption (W)	25	33	25	33
Power Rating (V/Hz)	120V / 60 Hz	120V / 60 Hz	120V / 60 Hz	120V / 60 Hz
Duct Diameter (In.)	4 & 6	4 & 6	4 & 6	4 & 6
Grille Size (In.)	13 x 14	13 x 14	13 x 14	13 x 14
Housing Size - L x W x H (In.)	11.375 x 10.5 x 7.625	11.375 x 10.5 x 7.625	11.375 x 10.5 x 7.625	11.375 x 10.5 x 7.625

**\*DO NOT USE FOR CONSTRUCTION**

**CONSULT FACTORY FOR CERTIFIED PRINTS**

**Continental Fan Manufacturing Inc.**  
203 Eggert Road  
Buffalo, New York 14215

**Continental Fan Canada Inc.**  
12-205 Matheson Blvd E  
Mississauga, Ontario L4Z 3E3

**Continental Fan Manufacturing Inc.**  
6274 Executive Blvd.  
Dayton, Ohio 45424