

SDC

12Vdc Oil Burner Manual

Beckett

RESIDENTIAL BURNERS

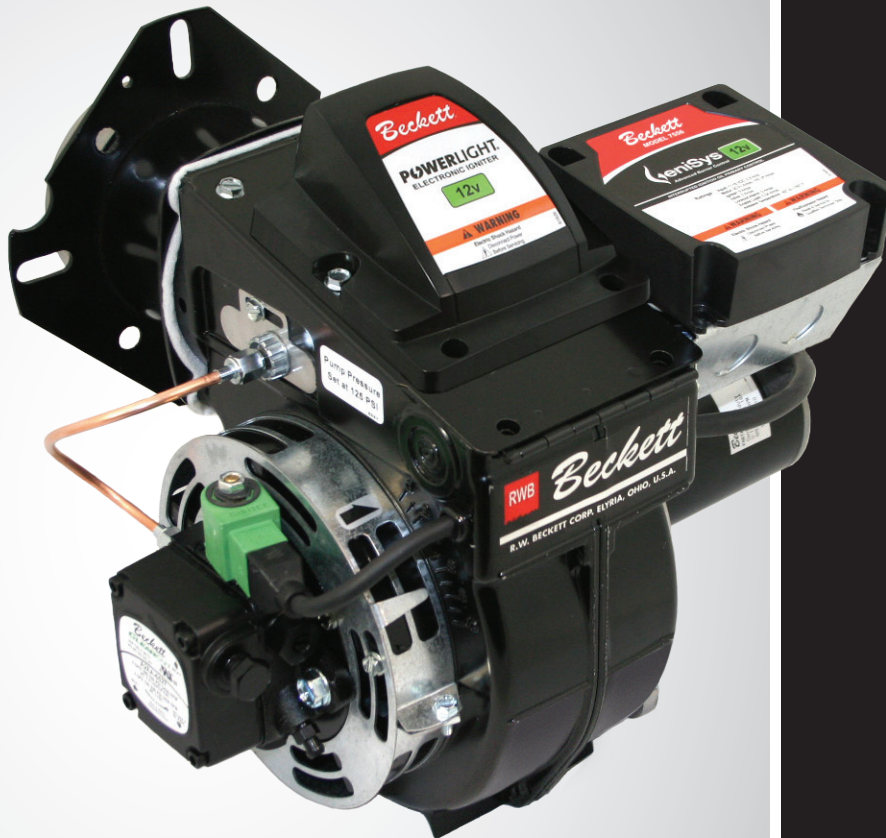

WARNING

Potential for Fire, Smoke and Asphyxiation Hazards



Incorrect installation, adjustment, or misuse of this burner could result in death, severe personal injury, or substantial property damage.

To the Homeowner or Equipment Owner:

- Please read and carefully follow all instructions provided in this manual regarding your responsibilities in caring for your heating equipment.
- Contact a professional, qualified service agency for installation, start-up or service work.
- READ THESE INSTRUCTIONS AND SAVE FOR REFERENCE.

To the Professional, Qualified Installer or Service Agency:

- Please read and carefully follow all manual instructions and any supplements provided, before installing, starting, or servicing this burner or heating system.
- The Installation must be made in accordance with all state and local codes having jurisdiction.

Contents

Burner Application Scope and Intended Use 2

Prepare Before Installing 3
 General Specifications 3
 Notice Special Requirements 3

General Information 4
 A. Equipment Located in Confined Space 4
 B. Exhaust Fans and Other Air-Using Devices 4
 C. Clearances to Burner and Equipment 4
 D. Exhausting Hazardous Fumes 4

Nozzle Assembly Maintenance 5
 A. Replace the Burner Nozzle 5
 B. Check/Adjust Electrodes 5
 C. Igniter Maintenance 6
 D. Servicing Nozzle Line Assembly 6
 E. Check/Adjust “Z” Dimension 6

Fuel Supply 7
 A. Connect Fuel Lines 7
 B. Fuel Supply Level with or Above Burner 7
 C. Fuel Supply Below Level of Burner 7
 D. Fuel Line Replacement (Remote Tank Only) 7
 E. Fuel Line Valve and Filter 7

Burner Wiring 7
 A. Burner installed on equipment 7
 B. Burner Replacement 7

Drive Component Maintenance 9
 A. Motor, Blower Wheel, and Coupling Replacement 9
 B. Pump Maintenance 10
 C. Solenoid Valve Testing 10

Start Up Burner & Set Combustion 10
 A. Basic Burner Operation 10
 B. Combustion Set-up 11
 C. Set Combustion with Instruments 11



Maintain & Service Burner 12
 A. Owner’s Information 12
 B. Owner Service and Maintenance 12
 Extended Down Time 12
 Regular Service/Maintenance 12

Troubleshooting 13

Replacement Parts 15

Limited Warranty Information 16

Hazard Definitions:

	Indicates a hazardous situation that, if not avoided, <i>will</i> result in death or serious injury .
	Indicates a hazardous situation that, if not avoided, <i>could</i> result in death or serious injury .
	Indicates a hazardous situation that, if not avoided, <i>could</i> result in minor or moderate injury .
	Used to address practices not related to physical injury.
	Safety instructions signs indicate specific safety-related instructions or procedures.

Burner Application Scope and Intended Use

The DC burner is designed for use in pressure washer, road maintenance equipment, and many other applications that have DC voltage charging systems capable of sustaining the specified voltage requirements. For other equipment applications, please contact Beckett Technical Services at 1-800-645-2876.

Prepare Before Installing

WARNING Owner's Responsibility



Incorrect installation, adjustment, and use of this burner could result in severe personal injury, death, or substantial property damage from fire, carbon monoxide poisoning, soot or explosion.

Contact a professional, qualified service agency for the installation, adjustment and service of your oil heating system. This work requires technical training, trade experience, licensing or certification in some states and the proper use of special combustion test instruments.

Please carefully read and comply with the following instructions:

- Never store or use gasoline or other flammable liquids or vapors near this burner or appliance.
- Never attempt to burn garbage or refuse in this appliance.
- Never attempt to light the burner/appliance by throwing burning material into the appliance.
- Never attempt to burn any fuel not specified and approved for use in this burner.
- Never restrict the air inlet openings to the burner or the combustion air ventilation openings in the room.

WARNING Impaired Burner Performance and Fire Hazard.

Do NOT operate the burner beyond specifications outlined in the table to the right.

- For applications beyond these limits, consult Beckett Technical Service at 1-800-645-2876.
- NOTE: Some packaged appliances with burners may be agency listed as a unit to operate beyond these limits. Consult the appliance manufacturer's specifications and agency approvals for verification.

General Specifications

Capacity	<i>F' Head</i> Firing rate: 1.75 – 5.50 GPH Input: 245,000 - 770,000 Btu/h
Fuels	USA: No. 1 or No. 2 diesel fuel or kerosene; No.1 or No. 2 heating oil (ASTM D396)  CAUTION DO NOT USE GASOLINE, CRANKCASE OIL, OR ANY OIL CONTAINING GASOLINE.
Electrical	<i>Power supply:</i> 13.5 VDC <i>Operating load:</i> 25 Amps (Actual draw could be less depending on application) <i>Motor:</i> 13.5 VDC, 1/4 hp, 3450 rpm, 18.75 Amps (max.), NEMA "M" flange, rotation CCW when facing shaft end. <i>Ignition Secondary:</i> 20KVpk 25mA Interrupted duty OR optional continuous duty, solid-state ignition
Pump	<i>Outlet pressure:</i> Note 1
Air tube	<i>ATC code:</i> See Table 1 on page 4 .
Dimensions	<i>Height (maximum):</i> 12-1/2 inches <i>Width (maximum):</i> 14-7/8 inches <i>Depth (chassis only):</i> 8-1/2 inches
Ambient Operating Temperature	+32° F. (0° C.) Minimum +115° F. (+46° C.) Maximum (See Warning on Impaired Burner Performance and Fire Hazard.)

Note 1. See equipment manufacturer's burner specifications for recommended outlet pressure. Pressure is 100 psig unless otherwise noted.

Notice Special Requirements

NOTICE

If you discover damage to the burner or controls during unpacking, notify the carrier at once and file the appropriate claim.

NOTICE

When contacting Beckett for service information — Please record the burner serial number (and have available when calling or writing). You will find the serial number on the silver label located on the left rear of the burner. See **Figure 1** on **page 4**.

General Information

Your burner was designed, installed and adjusted at the factory prior to shipment and should not require additional adjustments. Refer to the Troubleshooting section of this manual when experiencing a possible fault condition.

⚠ WARNING

Adequate Voltage Required

A low or erratic power supply could result in impaired burner operation, severe delayed ignition or an explosion inside the heat exchanger resulting in a burn and/or asphyxiation hazard.

- The Model SDC requires a continuous supply of 11V to 16V DC at 15A measured at the burner during operation.
- An automotive or small engine charging system that is capable of supplying the required continuous voltage/ amperage is recommended with certain road equipment, such as asphalt hot patchers and similar applications.
- This is especially true while maintaining nominal load temperatures during idle periods.

⚠ WARNING

Adequate Combustion and Ventilation Air Supply Required

Failure to provide adequate air supply could seriously affect the burner performance and result in damage to the equipment, asphyxiation, explosion or fire hazards.

- The burner cannot properly burn the fuel if it is not supplied with a reliable combustion air source.
- Follow the guidelines in the latest editions of the NFPA 31 and CSA-B139 regarding providing adequate air for combustion and ventilation.

A. Equipment Located in Confined Space

The confined space should have two permanent openings: one near the top of the enclosure and one near the bottom of the enclosure. Each opening shall have a free area of not less than one square inch per 1,000 BTU's per hour of the total input rating of all equipment within the enclosure. The openings shall have free access to the building interior, which should have adequate infiltration from the outside.

B. Exhaust Fans and Other Air-Using Devices.

Size air openings large enough to allow for all air using devices in addition to the minimum area required for combustion air. If there is any possibility of the equipment room developing negative pressure (because of exhaust fans, for example), either pipe combustion directly to the burner or provide a sealed enclosure for the burner and provide it with its own combustion air supply.

C. Clearances to Burner and Equipment

Provide space around burner and equipment for easy service and maintenance. Check minimum clearances against those shown by the equipment manufacturer and by applicable codes.

D. Exhausting Hazardous Fumes

See warning on this page. Also be conscious of any fumes produced by the materials that are being heated. Always ensure adequate ventilation to exhaust all fumes.

Table 1. Combustion Head Firing Rates

Firing Rate GPH (min - max)	Head
1.75 - 3.25	F22/F220
2.50 - 5.50	F310

Figure 1. Typical Burner Nameplate

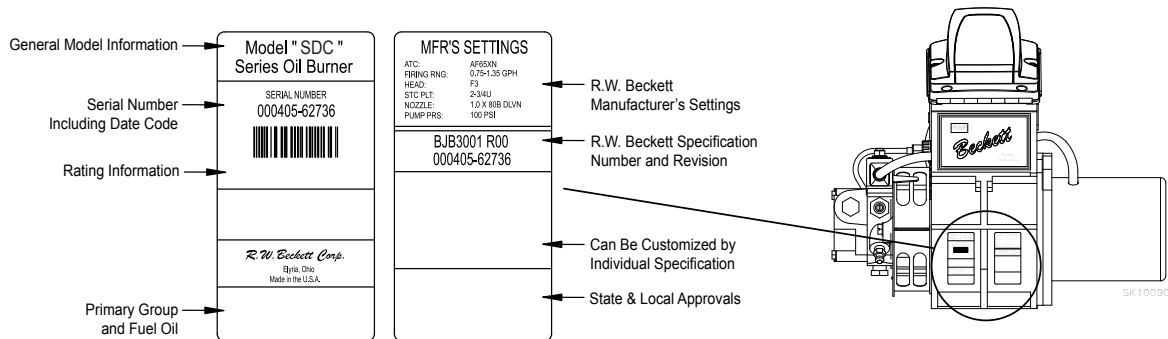

Nozzle Assembly Maintenance



Correct Nozzle and Flow Rate Required



Incorrect nozzles and flow rates could result in impaired combustion, under-firing, over-firing, sooting, puff-back of hot gases, smoke and potential fire or asphyxiation hazards.

Use only nozzles having the brand, flow rate (gph), spray angle and pattern specified by the appliance manufacturer.

Follow the appliance manufacturer's specifications for the required pump outlet pressure for the nozzle, since this affects the flow rate.

- Nozzle manufacturers calibrate nozzle flow rates at 100 psig.
- When pump pressures are higher than 100 psig, the actual nozzle flow rate will be greater than the gph stamped on the nozzle body. (Example: A 1.00 gph nozzle at 140 psig = 1.18 gph)

Securely tighten the nozzle (torque: 90 in. lbs). For typical nozzle flow rates at various pressures refer to **Table 2** on **page 13**.

A. Replace the Burner Nozzle.

1. If applicable, remove the plastic plug protecting the nozzle adapter threads.
2. Place a 3/4" open-end wrench on the nozzle adapter. Insert the nozzle into the adapter and finger tighten. Finish tightening with a 5/8" open-end wrench.
3. If the nozzle is already installed, remove the nozzle line assembly to verify that the nozzle size and spray pattern are correct for the application (per equipment manufacturer's information). Verify that the electrode tip settings comply with **Figure 2**.



Use care when removing or installing an oil nozzle

A damaged nozzle could cause impaired combustion, sooting, puffback of hot gases, oil leakage and potential fire or asphyxiation hazards.

- Inspect the nozzle adapter to insure that the sealing surface is not grooved or scratched.
- To insure that the nozzle functions properly, check the orifice and strainer for dirt, scratches or other damage before installation.
- Do NOT attempt to install or remove a nozzle without securing the adapter to prevent seriously damaging the alignment.
- Use care when handling the nozzle line assembly to prevent changing the electrode tip settings or damaging the ceramic electrode insulators.
- Ensure that the electrode settings match the values shown in **Figure 2**.

B. Check/Adjust Electrodes

Check the electrode tip settings. Adjust if necessary to comply with the dimensions shown in **Figure 2**. To adjust, loosen the electrode clamp screw and slide/rotate electrodes as necessary. Securely tighten the clamp screw when finished.

Figure 2. Electrode Tip Setting

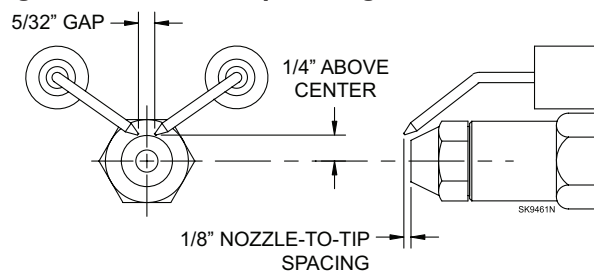
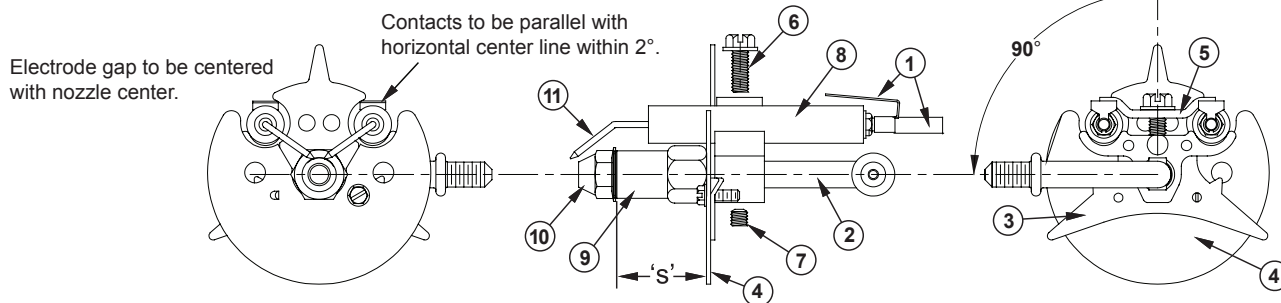

Figure 3. Nozzle, Line & Electrode Assembly



Item #	Description	Item #	Description	Air Tube Length	Dimension 'S'
1	Electrode Contact (3" ATC or extension over 3")	7	Nozzle line setscrew	2-5/8" to 3"	1-3/8"
2	Nozzle Line	8	Electrode Insulator	3-5/8" to 4-1/2"	1-5/8"
3	Spider spacer assembly	9	Nozzle adapter	over 4-7/8"	2-13/32"
4	Static Plate	10	Nozzle tip		
5	Electrode clamp	11	Electrode tip		
6	Electrode clamp retaining screws				

C. Igniter Maintenance

The igniter assembly does not require any adjustments beyond making sure the springs and the burner electrode rods make solid contact when the igniter is in the closed position. The sealing surfaces of the gaskets should be checked and replaced at the first signs of any damage or deterioration. Clean any dirt or residue from the porcelain bushings, springs, and baseplate.

The simplest way to check igniter operation is by supplying voltage to the input and checking to see whether an arc is produced. Check by either looking or listening to see if there is an arc across the electrodes while the burner is running and the igniter is energized.

The igniter must be grounded to the burner before checking the following. To check the igniter, ensure all power to the burner is off and use an ohmmeter to check the resistance between the two springs. The meter should read between 480 - 580 ohms.

The igniter should be replaced if the meter indicates an open circuit, or the spring-to-spring resistance exceeds the 480 - 580 ohms range by more than 10%.

D. Servicing Nozzle Line Assembly

Before proceeding, turn off power to the burner.

1. Disconnect the oil connector tube from the nozzle line.
2. Referring to **Figure 4**, remove the two hex head screws (**c**) securing the igniter baseplate. Then tilt the igniter back on its hinge.
3. Remove the splined nut.
4. Remove the nozzle line assembly from the burner, being careful not to damage the electrodes or

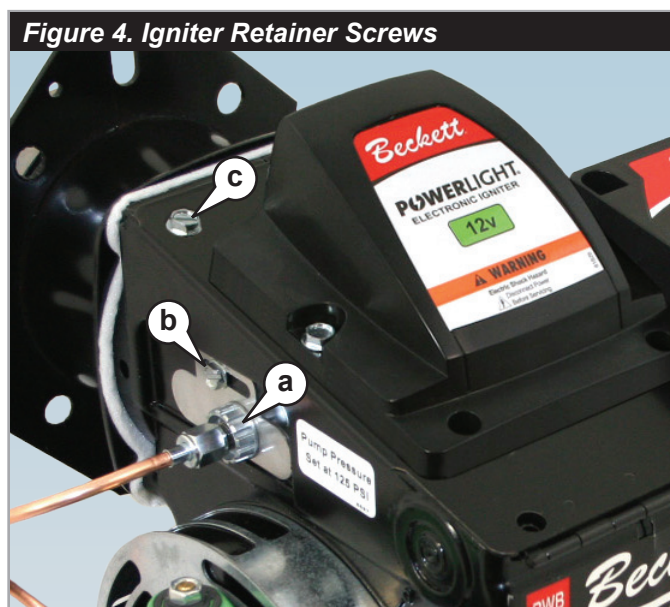

insulators while handling. To ease removal of short assemblies, it may be necessary to loosen the escutcheon plate. Reset to the edge of the label.

5. To replace the nozzle line assembly, reverse the above steps.

E. Check/Adjust “Z” Dimension

Refer to **Figure 5**. The critical “Z” dimension is the distance from the face of the nozzle to the flat face of the head. This distance for F heads is 1-1/8”. The “Z” dimension is factory set for burners shipped with the air tube installed but should always be verified during service and installation. If the “Z” dimension is out of adjustment, perform the following steps.

Before proceeding, turn off power to the burner.

1. Disconnect the oil connector tube from the nozzle line.
2. Referring to **Figure 4**, loosen the splined nut (**a**) from the nozzle line. Loosen the hex head screw (**b**) securing the escutcheon plate to the burner housing.
3. A Beckett T650 gauge should be used to set the Z dimension. See **Figure 5**.
4. Place the end of a ruler at the face of the nozzle and, using a straight edge across the head, measure the distance to the face of the head.
5. Slide the nozzle line forward or back until this dimension for F heads is 1-1/8”.
6. Tighten the hex head screw to secure the escutcheon plate to the burner chassis. Then tighten the splined nut and attach the oil connector tube.
7. Recheck the “Z” dimension periodically when servicing to ensure the escutcheon plate has not shifted. You will need to reset the “Z” dimension if you replace the air tube or nozzle line assembly.

NOTICE

The Beckett Z gauge (part number Z-2000) is available to permit checking the F head “Z” dimension without removing the burner.

Figure 5. ‘Z’ Dimensions Using Gauge

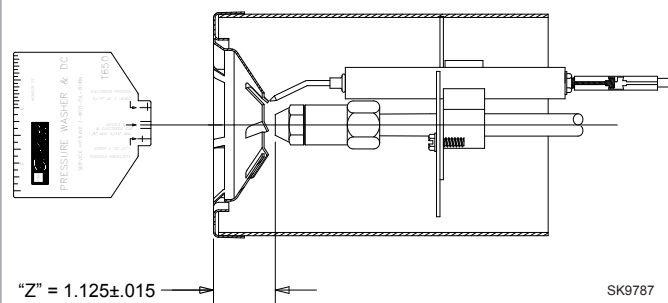

Fuel Supply



WARNING

Do Not Install Bypass Plug with 1-Pipe System

Failure to comply could cause immediate pump seal failure, pressurized oil leakage and the potential for a fire and injury hazard.

- The burner is shipped without the bypass plug installed.
- Install the bypass plug in two-pipe oil supply systems ONLY.



CAUTION

Oil Supply Pressure Control Required

Damage to the filter or pump seals could cause oil leakage and a fire hazard.

- The oil supply inlet pressure to the burner **cannot exceed 3 psig**.
- Ensure that a pressure limiting device is installed in accordance with the latest edition of NFPA 31.
- **Do NOT install valves in the return line.** (NFPA 31, Chapter 8.)
- **Gravity Feed Systems:** Always install an anti-siphon valve in the oil supply line or a solenoid valve (RWB Part # 22246U) in the pump/nozzle discharge tubing to provide backup oil flow cut-off protection.



CAUTION

Do Not Use Teflon Tape

Damage to the pump could cause impaired burner operation, oil leakage and appliance soot-up.

- Never use Teflon tape on fuel oil fittings.
- Tape fragments can lodge in fuel line components and fuel unit, damaging the equipment and preventing proper operation.
- Use oil-resistant pipe sealant compounds.

A. Connect Fuel Lines

For oil supply system specifications for tanks not mounted on machines, carefully follow the pump manufacturer's literature and the latest edition of the National Fire Protection Association (NFPA) 31 standard.

NOTICE

Pumps with automatic bypass do not require a bypass plug. Verify by referring to the pump manufacturer's instructions.

B. Fuel Supply Level with or Above Burner

The burner may be equipped with a single stage pump. If a one-pipe system is installed, insure that a bypass plug

is not installed in the pump, then connect the fuel supply to the burner with a single supply line. Note that manual bleeding of the pump is required on initial start-up or when the equipment runs out of fuel. When connecting a two-pipe fuel system, install the pump by-pass plug.

C. Fuel Supply Below Level of Burner

When the fuel supply is more than eight feet below the level of the burner, a two-pipe fuel supply system is required. Depending on the fuel line diameter and the horizontal and vertical length, the installation may also require a two-stage pump. Consult the fuel unit manufacturer's literature for lift and vacuum capability.

D. Fuel Line Replacement (Remote Tank Only)

When replacing fuel lines, continuous lengths of heavy wall copper tubing is recommended. To ensure a tight seal, always use flare fittings. Never use compression fittings. Always install fittings in an accessible location. To avoid vibration noise, fuel lines should not run against the appliance or the ceiling joists.

E. Fuel Line Valve and Filter

Shutoff valves should be located in the oil supply line. Do not install valves in the return line.

Burner Wiring



WARNING

Electrical Shock Hazard

Electrical shock can cause severe personal injury or death.

- Disconnect electrical power before installing or servicing the burner.
- Provide ground wiring to the burner, metal control enclosures and accessories. (This may also be required to aid proper control system operation.)

A. Burner installed on equipment

Refer to appliance manufacturer's wiring diagram for electrical connections.

B. Burner Replacement

Burner wiring may vary, depending on the actual primary control and furnished options. Refer to **Figure 6** for typical burner wiring, showing cad cell primary controls. Note that the relay and control, shown in the wiring diagram are optional features.

NOTICE

The wiring diagrams in this manual are for general reference only. Refer to the equipment manufacturer's literature or the diagrams supplied with the equipment.

Figure 6A. Typical Wiring For Constant Duty Ignition - With No Primary Control

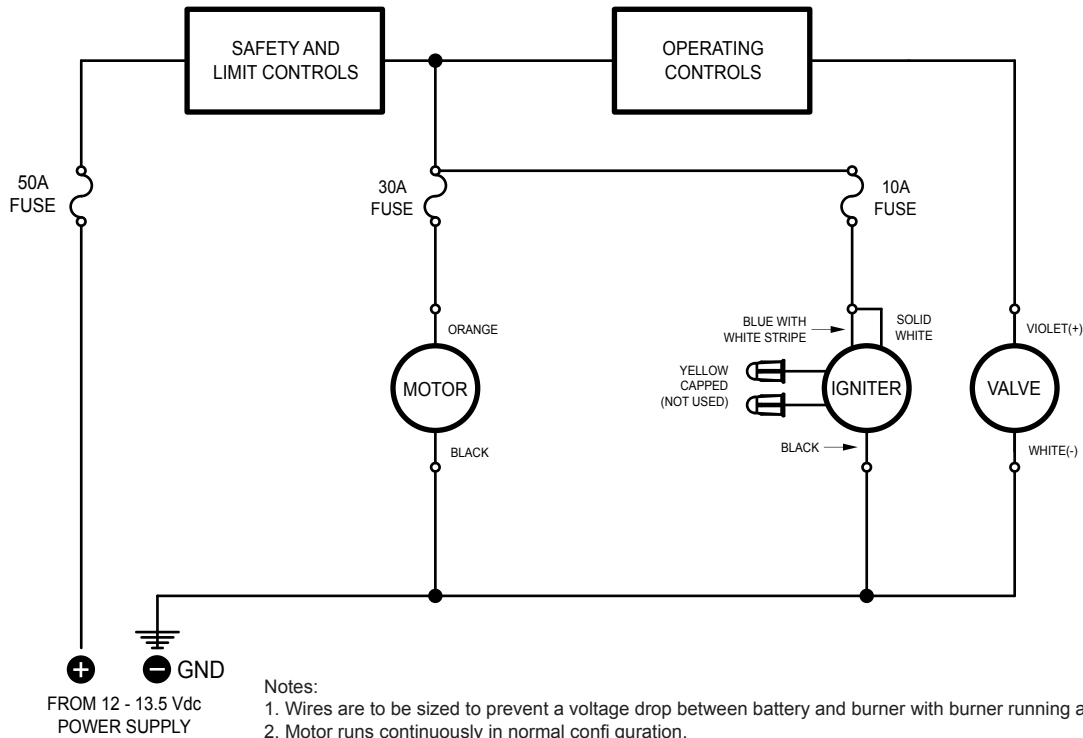

- Notes:
1. Wires are to be sized to prevent a voltage drop between battery and burner with burner running at full load.
 2. Motor runs continuously in normal configuration.
 3. Hard-wire burner ground to battery. DO NOT USE CHASSIS GROUND SYSTEM.

SK10087

Figure 6B. Typical Wiring For Interrupted Ignition - With No Primary Control

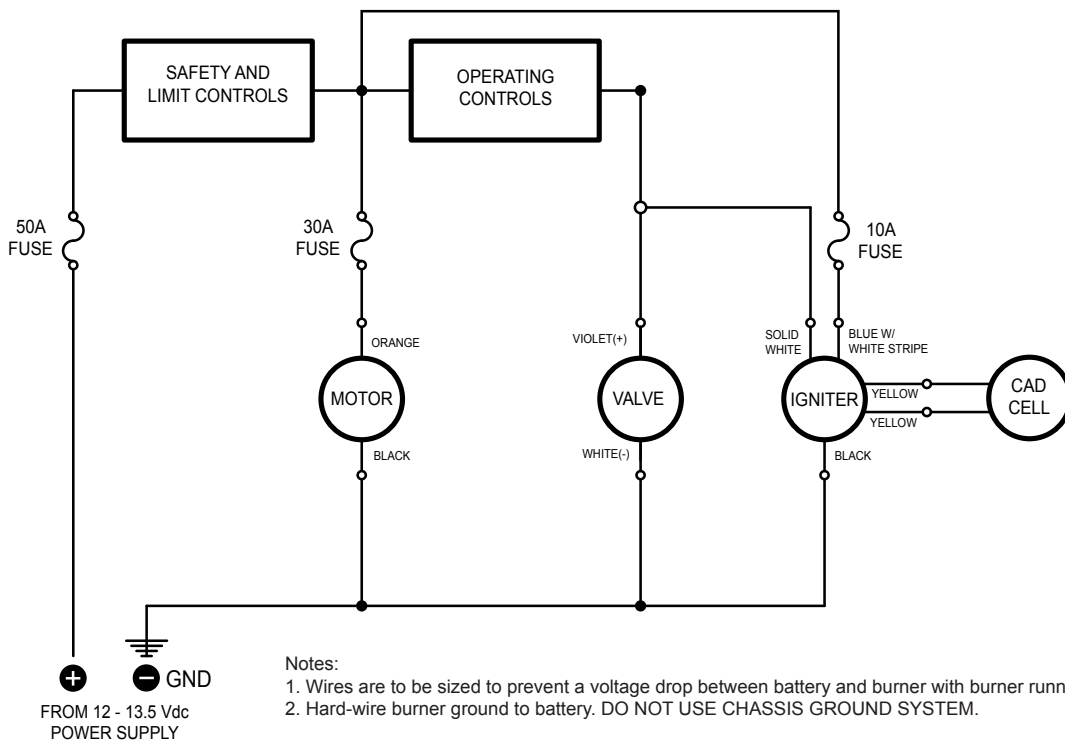

- Notes:
1. Wires are to be sized to prevent a voltage drop between battery and burner with burner running at full load.
 2. Hard-wire burner ground to battery. DO NOT USE CHASSIS GROUND SYSTEM.

SK10088

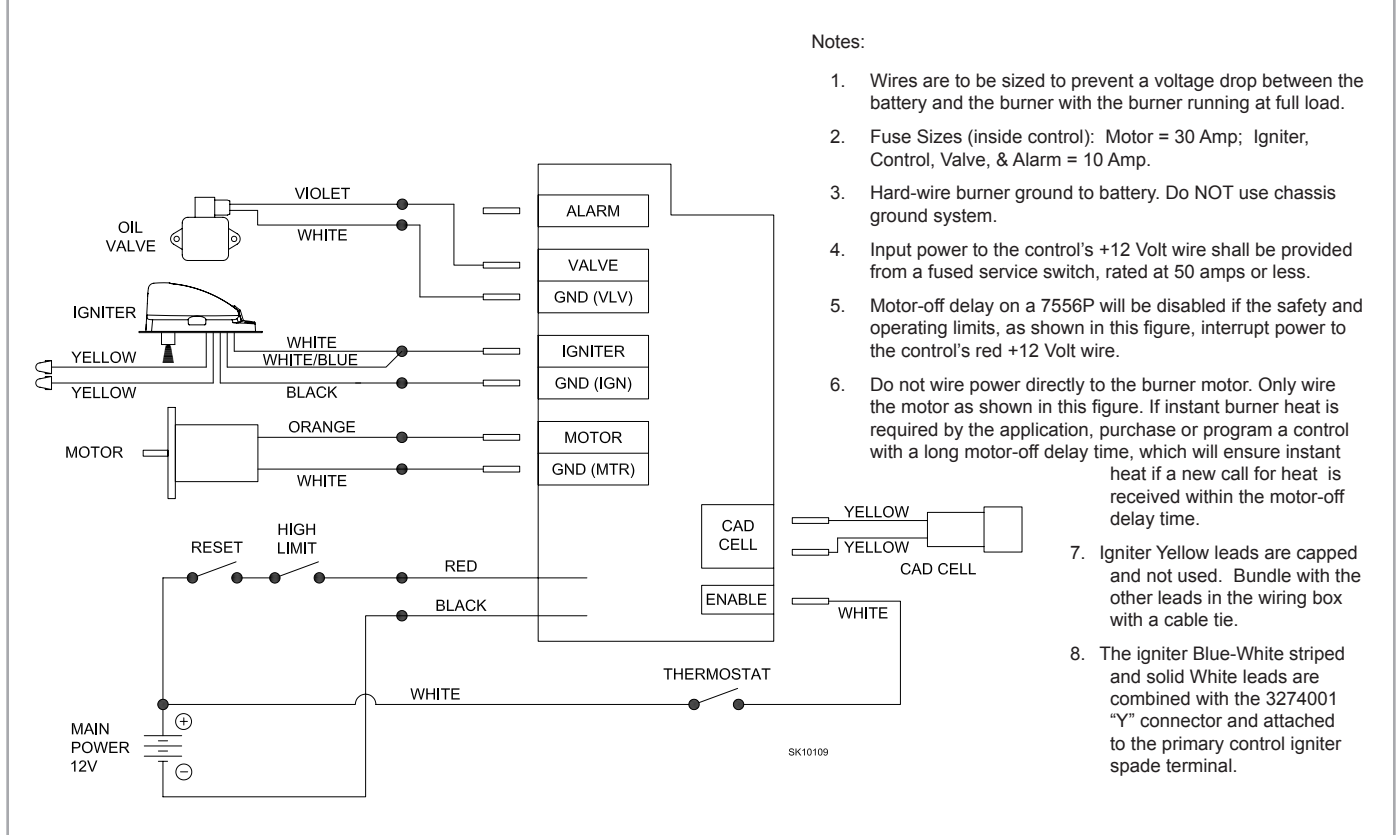
Figure 6C. Typical Wiring with 7556 Primary Safety Control

Drive Component Maintenance

A. Motor, Blower Wheel, and Coupling Replacement

The motor will require replacement if the proper voltage is measured at the motor input, and the motor will either not run, or the current draw with a free running pump exceeds 10% of the rated current.

To replace the burner motor, coupling and/or blower wheel perform the following steps.

1. Before servicing, turn off and/or disconnect all power to the burner.
2. Disconnect the burner motor wires.
3. Remove the bolts securing the motor to the burner housing.
4. Remove the motor, coupling, and blower wheel.
5. Loosen the set screw on the blower wheel to slide the existing wheel off the shaft.
6. Slide the new blower wheel onto the old shaft (after thoroughly cleaning housing) and/or slide the old blower wheel onto the new motor shaft.
7. When replacing the blower wheel, ensure the wheel is centered between the two sides of the burner housing as shown.

8. Rotate the blower wheel until the setscrew is centered on the flat of the motor shaft. Tighten the setscrew to secure the wheel.
9. Slide the motor coupling on the motor shaft, then install the motor on the burner housing. Ensure that the motor coupling fits between the motor shaft and the pump shaft inside the housing. Tighten the motor retaining screws. Reconnect the wires.
10. Restore power, start the burner and perform the combustion test described previously in this manual.

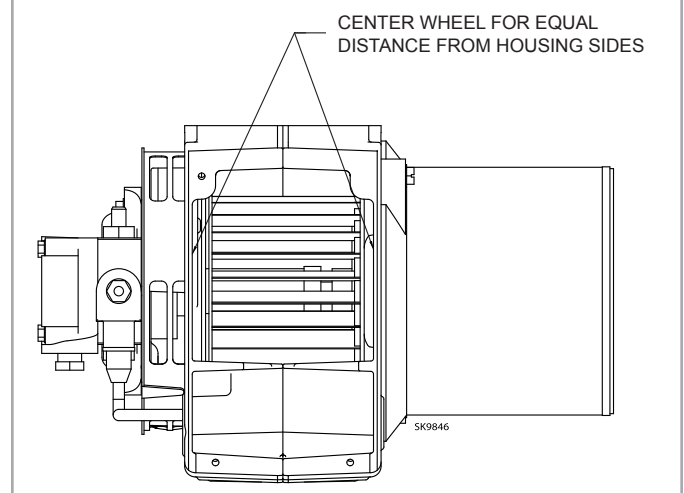
Figure 7. – Blower Wheel

B. Pump Maintenance

General Pump Information

Important information - Long or oversized inlet lines may require the pump to operate dry during initial bleeding period. In such cases, the priming may be assisted by injecting fuel oil in the pump gear set. Under lift conditions, lines and fittings must be air tight. To assure this, "Pipe Dope" may be applied to both the used and unused inlet and return fittings. **Do NOT use Teflon tape or compression fittings**

Mounting Position

Beckett CleanCut pump may be mounted in any position (except upside-down in a single pipe installation).

Vacuum Check

A Vacuum Gauge may be installed in either of the 1/4" NPT inlet ports.

Pressure Check

When a pressure check is made use the nozzle port. If the bleed port is used, the reading on the gauge should be approximately 5 psig higher than the pressure reading on the nozzle port. See **Figure 9**.

Cutoff Check

To check cutoff pressure dead head a pressure gauge in the nozzle port. Run the burner for a short period of time. Shut the burner off. The pressure will drop and hold above zero. Pressurized or gravity feed installations must not exceed 3 psi on inlet line or return line at the pump per NFPA 31. A pressure greater than 10 psi may cause damage to the shaft seal.

Pressurized or Gravity Feed Installations

Must not exceed 3 psi on inlet line or return line at the pump per NFPA 31. A pressure greater than 10 psi may cause damage to the shaft seal.

C. Solenoid Valve Testing

To check solenoid operation, perform the following.

1. Check for oil flow and operating pressure by removing the copper tubing from the nozzle line and installing a pressure gauge in the line. With the motor running and the coil energized, check the gauge. The pressure should read 100 psig unless otherwise stated.
2. To check the solenoid valve cutoff function, deadhead the pressure gauge onto the copper connector tube attached to the nozzle port. Run the burner for a short period of time. Shut the burner off. The solenoid valve should close and the pressure should drop and hold.
3. Replace the solenoid valve if it does not pass the steps above.

Start Up Burner & Set Combustion

A. Basic Burner Operation

Typical Constant Duty Ignition Configuration

With this Beckett ADC oil burner configuration, the motor and igniter operate continuously while the valve that controls oil flow is cycled by the switches on the power washer. The motor is used to drive the blower and pump. The rotational speed of the motor is determined by the voltage supplied and the load placed on the motor. Pump pressure and air settings are the main factors affecting the motor load. The igniter converts battery DC voltage into a high voltage spark to ignite the oil. The igniter is capable of running continuously as long as the blower wheel is circulating air across the igniter base. The pump and solenoid valve are used to control the flow of oil from the reservoir to the nozzle.

Igniter With Interrupted Duty Ignition

This optional control circuit is available to reduce current draw on the charging system by turning the igniter off after a flame has been established. This option controls igniter operation based on a signal from a light sensing cad cell. When light hits the cell the control will sense a decrease in resistance across the sensor. A few seconds delay will occur prior to the igniter switching off. As long as sufficient light is reaching the cell eye, the igniter will remain off. If light is removed from the sensor, the igniter will turn on until light is again sensed by the cad cell.

With 7556 Primary Safety Control

The 7556 control provides the same benefits as described above, as well as added safety, convenience, and performance features. It adds a valve on delay and motor-off delay to the burner's operation sequence that promote clean burner operation. It has a lock-out function that shuts the burner down if it is not operating properly. The control adds fusing at the burner to protect against component failures. The control also has redundant motor relays that are checked for proper operation every heat cycle.

NOTICE

Variations to the burner circuits may occur due to optional temperature, pressure, and vacuum switches that control burner operation. Note that when external switches are used to control motor operation they must be sized correctly for the rated current or a relay should be installed to isolate the switches from the motor's full load current.

B. Combustion Set-up

WARNING

Explosion and Fire Hazard



Failure to follow these instructions could lead to equipment malfunction and result in heavy smoke emission, soot-up, hot gas puff-back, fire and asphyxiation hazards.

- Do not attempt to start the burner when excess oil has accumulated in the appliance, the appliance is full of vapor, or when the combustion chamber is very hot.
- Do not attempt to re-establish flame with the burner running if the flame becomes extinguished during start-up, venting, or adjustment.
- **Vapor-Filled Appliance:** Allow the unit to cool off and all vapors to dissipate before attempting another start.
- **Oil-Flooded Appliance:** Shut off the electrical power and the oil supply to the burner and then clear all accumulated oil before continuing.
- If the condition still appears unsafe, contact the Fire Department. Carefully follow their directions.
- Keep a fire extinguisher nearby and ready for use.

Figure 9. – Air supply components

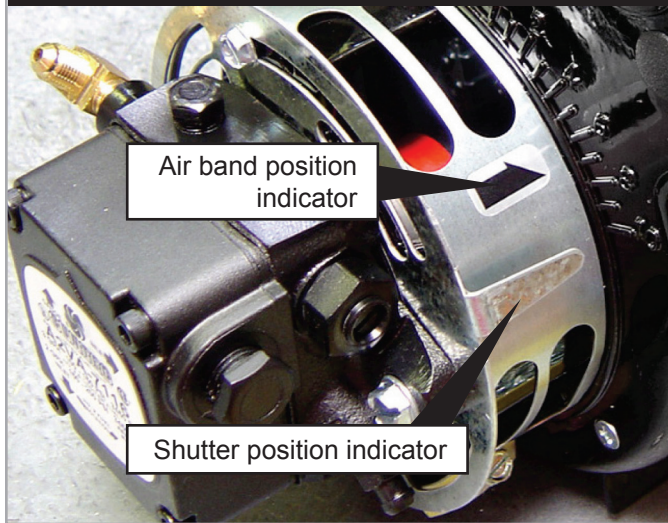

As soon as burner motor starts rotating bleed all the air from the pump. (Required with single-pipe systems.)

To bleed the pump, attach a clear plastic hose over the vent fitting. Loosen the fitting and catch the oil in an empty container. Tighten the fitting when all air has been purged from the supply system. Note: If the burner stops after a flame is established, the unit probably requires additional bleeding. Continue to bleed the system until the pump is primed and a flame is established when the bleed valve is closed.

C. Set Combustion with Instruments

WARNING

Professional Service Required



Incorrect installation, adjustment, and use of this burner could result in severe personal injury, death, or substantial property damage from fire, carbon monoxide poisoning, soot or explosion.

Please read and understand the manual supplied with this equipment. This equipment must be installed, adjusted and put into operation only by a qualified individual or service agency that is:

- Licensed or certified to install and provide technical service to oil heating systems.
- Experienced with all applicable codes, standards and ordinances.
- Responsible for the correct installation and commission of this equipment.
- Skilled in the adjustment of oil burners using combustion test instruments.

The installation must strictly comply with all applicable codes, authorities having jurisdiction and the latest revision of the National Fire Protection Association Standard for the installation of Oil-burning Equipment, NFPA 31 (or CSA-B139 and CSA-B140 in Canada). Regulation by these authorities take precedence over the general instructions provided in this installation manual.

1. Allow the burner to run for approximately 5 to 10 minutes.
2. Follow these four steps to properly adjust the burner:
 - Step 1: Adjust the air until a trace smoke level is achieved..
 - Step 2: At the trace of smoke level, measure the CO₂ (or O₂). This is the vital reference point for further adjustments.
 - Step 3: Increase the air to reduce CO₂ by 1 percentage point (O₂ will be increased by approximately 1.4 percentage points).
 - Step 4: Recheck the smoke level. It should be zero.
3. This procedure provides a margin of reserve air to accommodate variable conditions.
4. Once the combustion level is set, tighten the fasteners on the air band and air shutter.
5. Start and stop the burner several times to ensure satisfactory operation.
6. Test the equipment safety controls to verify that they function according to the manufacturer's specifications.

Maintain & Service Burner

A. Owner's Information

Have your equipment inspected at regular intervals by a qualified service agency to assure continued proper operation. The burner should be adjusted using dedicated combustion test equipment. Failure to properly set the burner could result in inefficient operation, and/or conditions that could potentially cause severe personal injury, death or substantial property damage.

B. Owner Service and Maintenance

Properly installed and maintained, your ADC burner will provide years of efficient, trouble-free operation. Please take care of your equipment by following the warnings provided and by immediately contacting your qualified service agency if your burner is not operating properly. This equipment should be serviced only by a qualified service agency. The appropriate test instruments must be used.

Daily

Check the area around your burner/equipment to make sure:

- nothing is blocking the burner inlet air openings
- air ventilation openings are clean and unobstructed and the exhaust is not crusted
- no combustible materials are stored near the equipment
- there are no signs of oil or water leakage around the burner or equipment.

Extended Down Time

If the equipment will be stored for an extended period of time, insure that the fuel tank is full and add a fuel stabilizer to the tank.

Regular Service/Maintenance

Have your burner, serviced annually by your qualified service agency. The following components/assemblies should be checked/adjusted/replaced on a regular basis. Refer to the Replacement Parts exploded view for part locations.

- Replace the oil supply line filter if applicable. The line filter cartridge must be replaced to avoid contamination of the pump and nozzle.
- Inspect the oil supply system. All fittings should be leak-tight. The supply lines should be free of water, sludge and other restrictions.
- Remove and clean the pump strainer.
- Verify the nozzle is the one originally specified by the appliance manufacturer and replace the nozzle with one having the exact specifications from the same manufacturer.
- Clean and inspect the electrodes for damage, replacing any that are cracked or chipped.
- Check electrode tip settings. Replace electrodes if tips are rounded.
- Inspect the igniter spring contacts. Clean or replace if corroded.
- Clean the cad cell, if applicable.
- Make sure Low Firing Rate Baffle is in place, if required, for the burner application. Omitting the baffle can result in unacceptable burner combustion.
- Inspect all gasket including the igniter base plate gasket. Replace any that are damaged or missing.
- Clean the blower wheel, air inlet, air guide, retention head and static plate of any dirt, asphalt or other material.
- Check motor current. The amp draw should not exceed the nameplate rating. Check all wiring for loose connections or damaged insulation.
- Check the pump pressure and cutoff function.
- Check primary control safety lockout timing if applicable. Refer to the information supplied by the control manufacturer for procedures.
- Check ignition system for proper operation.
- Inspect the exhaust system for soot accumulation or other restriction.
- Clean the equipment thoroughly according to the manufacturer's recommendations.
- Check the burner performance using test instruments.
- It is good practice to make a record of the service performed and the combustion test results.

Troubleshooting

Oil burners that are designed for use in pressure washers are built to take temperature extremes, vibration, and rough handling. When performing the following troubleshooting steps, we assume that the oil burner motor and ignition transformer operate continuously and the oil solenoid valve, which controls oil flow, is cycled by the trigger in the wand. We also assume that there is power to the burner and fuel in the tank.

In addition to normal mechanics tools, it is recommended to have the following equipment on hand.

- Meter capable of measuring volts, ohms and amps,
- ignition transformer tester,
- smoke pump tester,
- combustion analyzer, and
- 0 to 200 psi pressure gauge.

See **Table 3** on **page 14** for troubleshooting steps.

Table 2. Nozzle Flow Rate by Size

Nozzle flow rate U. S. gallons per hour of No. 2 fuel oil when pump pressure (psig) is:		
Nozzle size (rated at 100 psig)	100 psi	140 psi
1.75	1.75	2.07
2.00	2.00	2.37
2.25	2.25	2.66
2.50	2.50	2.96
2.75	2.75	3.24
3.00	3.00	3.55
3.50	3.50	4.13
4.00	4.00	4.70
4.50	4.50	5.30
5.00	5.00	-

Table 3. Troubleshooting Chart

Symptom	Possible Cause
Oil Not Igniting	<p>If the burner is not igniting, the burner motor, drive coupling, and oil pump are operating and oil is flowing to the nozzle through the solenoid valve, check the following possibilities.</p> <ol style="list-style-type: none"> 1. Check the air shutter adjustment. If the air shutter is opened too far, the flow of air may prevent the arc from reaching the oil spray. This may appear as a white vapor exhaust from the heater. [Refer to section “Start up burner and set combustion”] 2. The ignition system may have failed to supply an adequate arc to ignite the oil. Check the battery and charging system to insure a continuous supply of 11 to 16 volts DC (15 amps). [Refer to section “Nozzle Assembly Maintenance”] 3. Check the electrodes for wear and damage. Insure that the electrodes are adjusted properly. [Refer to section “Nozzle Assembly Maintenance”]
No Flame	<p>If there is no flame, the burner motor and igniter operate continuously and the oil solenoid valve is functional, check the following possibilities.</p> <ol style="list-style-type: none"> 1. Check for a plugged oil nozzle. [Refer to section 3] 2. If the coil on the solenoid valve is actuating, insure that the valve is opening or closing properly. [Refer to section “Fuel Supply”] 3. Check for sufficient fuel pressure. Pressure is 100 psig with valve energized, unless otherwise noted. [Refer to section “Drive Component Maintenance”] 4. Check the pump pressure. Check for air in fuel lines. 5. Check burner for broken motor coupling. If the coupling is broken check pump rotation prior to replacing the coupling. [Refer to section “Drive Component Maintenance”] 6. Check for contaminated fuel and/or partially plugged fuel filter. [Refer to section “Fuel Supply”]
Motor Not Operating	<p>If the blower motor is not operating, check the following possibilities.</p> <ol style="list-style-type: none"> 1. Check voltage at the motor to insure that switches and relays, in line with the motor, are operating properly. [Refer to section “Burner Wiring”] 2. Check pump and motor shaft operation. They should work freely without binding. [Refer to section “Drive Component Maintenance”]
No Oil Spray	<p>If the blower motor is operating, there is fuel in the tank, but oil does not spray out the end of the nozzle, check the following possibilities.</p> <ol style="list-style-type: none"> 1. Check for a broken or stripped coupling between the pump and the motor. [Refer to section “Drive Component Maintenance”] 2. Check the pump output for oil. [Refer to section “Drive Component Maintenance”] 3. Check operation of the oil valve. [Refer to section “Drive Component Maintenance”] 4. Check for a plugged nozzle. [Refer to section “Nozzle Assembly Maintenance”] 5. Check for air in the oil line. [Refer to section “Nozzle Assembly Maintenance”] 6. Check for fuel contamination or plugged filter. [Refer to section “Nozzle Assembly Maintenance”]
Fluctuating or No Pump Pressure	<p>If the pump pressure, as determined by a pressure gauge, is erratic or does not exist, check the following possibilities.</p> <ol style="list-style-type: none"> 1. Check motor rotational speed. Low rpm can cause erratic or no pump pressure. [Refer to section “Drive Component Maintenance”] 2. Check for a broken or worn motor coupling. [Refer to section “Drive Component Maintenance”] 3. Check that the pump turns freely. [Refer to section “Drive Component Maintenance”] 4. Check for air leaks in the lines. [Refer to section “Fuel Supply”] 5. Check for oil froth at the bleed point. [Refer to section “Fuel Supply”] 6. Check voltage at the motor. [Refer to section voltage rating on nameplate] 7. Check for fuel contamination or partially plugged filter.
Slow Motor Rotation	<p>If the blower motor is not operating at the rpm’s listed on the nameplate, check the following.</p> <ol style="list-style-type: none"> 1. Check the supply voltage to the motor. [Refer to section voltage rating on nameplate] 2. Check for free operation of the motor shaft and pump assembly. [Refer to section “Drive Component Maintenance”]

Replacement Parts

For best performance specify genuine *Beckett* replacement parts

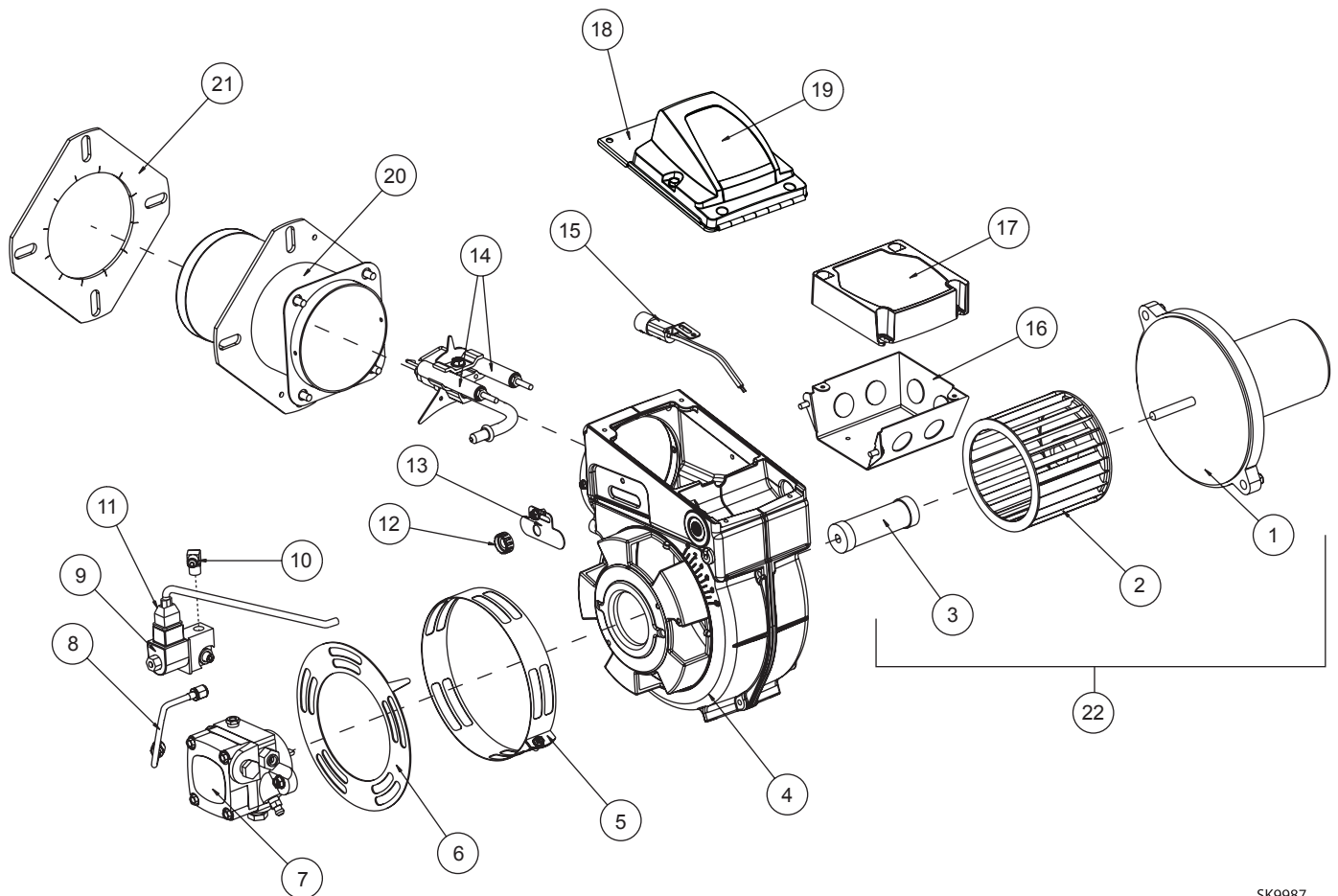

SK9987

Illustration #	Description	Part#
1	DC Motor	n/a
2	Blower Wheel (6-1/4")	2383AU
3	Coupling	2154101
4	Burner Housing	5348B
5	Air Band, 10 slot	3819A
6	Air Shutter, 10 slot	3215
7	Pump	Specify
8	Connector Tube Assembly	5394
9	Oil Valve	Specify
10	Brass Elbow	2256
11	Cord Set, Valve	21807
12	Splined Nut	3666

Illustration #	Description	Part#
13	Escutcheon Plate	3493
14	Electrode Kit over 3-5/8"	578731
15	Cad Cell Detector	7006U
16	4X4 Wiring Box	5770
17	Control Kit	7556X-XXXXU*
18	Igniter Assembly With Base Plate	5218303U
19	Igniter only	5218309U
20	Air Tube Assembly	Specify
21	Flange Mounting Gasket	Specify
22	Motor Kit with Blower Wheel and Coupling	52146U
Not Shown	Tune-up Kit for 30 and 35 Air Tube lengths	578730

* 'X's indicate timing options. Contact Beckett for available part numbers.

Limited Warranty Information

The R. W. BECKETT CORPORATION ("Beckett") warrants to persons who purchase its "Products" from Beckett for resale, or for incorporation into a product for resale ("Customers"), that its equipment is free from defects in material and workmanship. To qualify for warranty benefits, products must be installed by a qualified service agency in full compliance with all codes and authorities having jurisdiction, and used within the tolerances of Beckett's defined product specifications.

To review the complete warranty policy and duration of coverage for a specific product, or obtain a written copy of warranty form 61545, please choose one of the following options:

1. Visit our website at: www.beckettcorp.com/warranty
2. Email your request to: rwb-customer-service@beckettcorp.com
3. Write to: R. W. Beckett Corporation, P. O. Box 1289, Elyria, OH 44036

NOTE: Beckett is not responsible for any labor cost for removal and replacement of equipment.

THIS WARRANTY IS LIMITED TO THE PRECISE TERMS SET FORTH ABOVE, AND PROVIDES EXCLUSIVE REMEDIES EXPRESSLY IN LIEU OF ALL OTHER REMEDIES, AND IN PARTICULAR THERE SHALL BE EXCLUDED THE IMPLIED WARRANTIES OF MERCHANTABILITY AND FITNESS FOR A PARTICULAR PURPOSE. IN NO EVENT WILL BECKETT BE LIABLE FOR ANY INCIDENTAL OR CONSEQUENTIAL DAMAGE OF ANY NATURE. Beckett neither assumes, nor authorizes any person to assume for Beckett, any other liability or obligation in connection with the sale of this equipment. Beckett's liability and Customer's exclusive remedy is limited to the cost of the product.



USA: P.O. Box 1289 • Elyria, OH 44036
Canada: R.W. Beckett Canada, Ltd. • Unit #3, 430 Laird Road • Guelph, Ontario N1G 3X7
www.beckettcorp.com