

MANUFACTURED FOR:
MITSUBISHI ELECTRIC US, INC.

Hail Guard

HG-A1, HG-A2, HG-A3, HG-A4

for use with:

M-Series and P-Series Outdoor Units

INSTALLATION MANUAL

FOR INSTALLER

For safe and effective use of this kit, please read this installation manual thoroughly before installing these components

Contents

Contents	2
1. Dimensions	2
2. Inspect Shipment	4
3. Safety Precautions	4
4. Installation Considerations	4
5. Checking Parts	5
6. Installation Instructions	5

1. Dimensions

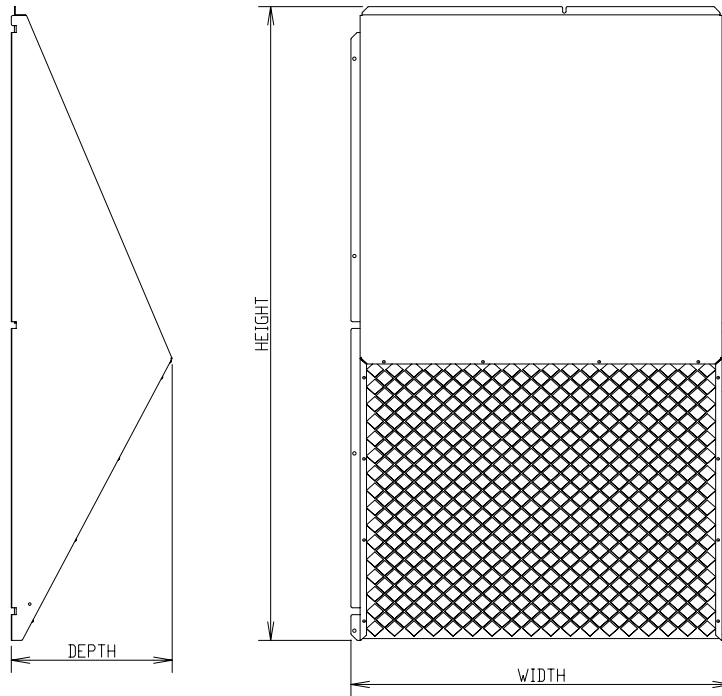

Table 1:

Material	Power Coated 20 gauge galvanized steel
Powder Coat	P1135-G6 Polyester TGIC Erie Powder Coating
	3 mil nominal (+/- 1 mil) uniform thickness over the entire part.
Color	Matches Outdoor Unit
Screen	1 inch (25.4 mm) square hole pattern

Table 2:

		HG-A1		HG-A2		HG-A3		HG-A4
		Rear	Side	Rear	Side	Rear	Side	
Kit	kg (lbs)	12.1 (26.68)		15.19 (33.48)		14.79 (32.61)		-
Weight	kg	7.49	4.61	9.99	5.20	9.45	5.35	3.23
	(lbs)	(16.51)	(10.17)	(22.02)	(11.46)	(20.83)	(11.79)	(7.13)
Height	mm	965	947	1310	1250	1313.2	1296.2	470
	(in)	(37.99)	(37.28)	(51.57)	(49.21)	(51.7)	(51.03)	(18.5)
Width	mm	737.25	299	791	208	726	207	701
	(in)	(29.03)	(11.77)	(31.14)	(8.19)	(28.58)	(8.15)	(27.6)
Depth	mm	332	326	332	326	332	326	201
	(in)	(13.07)	(12.83)	(13.07)	(12.83)	(13.07)	(12.83)	(7.91)

Table 3:

HAIL GUARD OUTDOOR UNIT	HG-A1	HG-A2	HG-A3	HG-A4
	MUZ-FH09/12NA(H)			
MXZ-2C20/3C24/3C30NAHZ	X			
MXZ-4C36NAHZ		X		
MXZ-5C42NA	X			
MXZ-5C42NAHZ		X		
MXZ-8B48NA			X	
MXZ-8C48NA/8C48NAHZ		X		
PUZ-HA30/36NHA4/5			X	
PUZ-HA42NKA		X		

2. Inspect Shipment

Upon receipt of equipment, carefully inspect it for possible damage. Take special care to examine the unit if the carton is damaged. If damage is found, it should be noted on the

carrier's freight bill. Damage claims should be filed with the carrier immediately. Claims of shortages should be filed with the seller within 5 days.

3. Safety Precautions

Carefully read this section, always observe for safety, and securely install the optional parts.

Be sure to observe the cautions described here:

- They include critical contents for safety.
- The following indications show the classifications for danger, and possible consequences following incorrect handling.
- After installation, perform a test run and make sure that there is no abnormality, and ask your customer to keep this installation sheet with the instruction manual at all times. Also ask the customer to transfer these manuals to a new user if the user changes.

Symbols used in the text

 **Warning:**
This symbol denotes incorrect handling could lead to death or serious injury

 **Caution:**
This symbol denotes incorrect handling could lead to injury or damage the house and household articles

-  **Warning:**
- **Ask the dealer or specialist for installation.**
 - If installed incorrectly by user, water leak, electric shock, fire, etc could result.
 - **Carefully install the panel according to this installation.**
 - Incorrect installation could cause water leak, electric shock or refrigerant leak.

-  **Caution:**
- **Do not place polyethylene bags in reach of young children.**
 - Putting them over the head will block breathing passages, which could result in suffocation.

4. Installation Considerations

These hail guards are used to prevent damage to the heat exchangers from hail stones with a diameter larger than 1 inch. They are also used to protect the coils from snow accumulation.

Installing of this product will reduce the capacity of the unit (approx. 2 or 3%) and increase the noise of the outdoor unit (approx. 1 or 2 dB).

5. Checking Parts

Note: Screws for all models are included, therefore some screws will not be used.

HG-A1
HG-A2
HG-A3

Description	Qty
Rear Guard	1
Side Guard	1
Mounting Screws	13 for A1
	13 for A2
	19 for A3

REAR GUARD

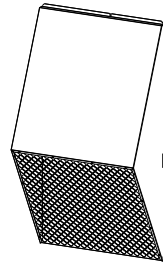

SIDE GUARD

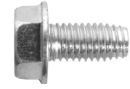

Mounting Screw
M5 x 10

HG-A4

Description	Qty
Side Guard	1
Mounting Screws	2

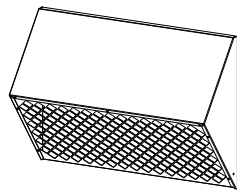

HG-A4



Mounting Screw
#8 x 1/2

6. Installation Instructions

HG-A1, -A2, Rear Guard

Step 0. Remove the existing screws.

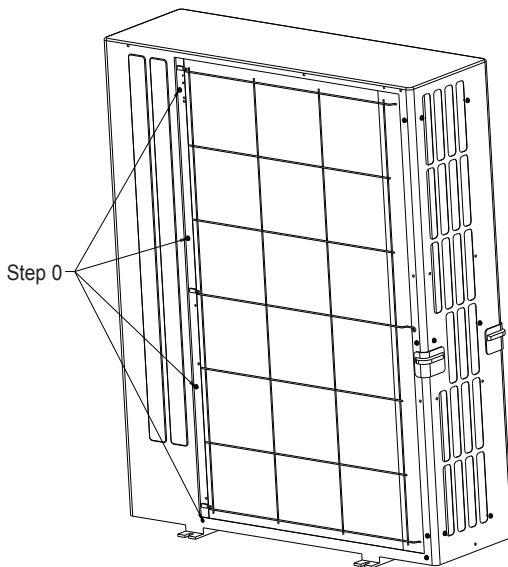

HG-A1, -A2, -A3 Rear Guard

Step 1. Loosening the screws in the top panel. Slide the top of the hail guard under the screw head and re-tighten enough to support the hail guards as you align the holes with the holes in the outdoor unit.

Step 2. Loosely tighten the hail guard with the screws provide.

Step 3. Check the alignment, and fully tighten the screws.

HG-A1, -A2, -A3 Side Guard

Step 1. Align side hail guard holes with existing screw holes on the outdoor unit and secure with screws provided.

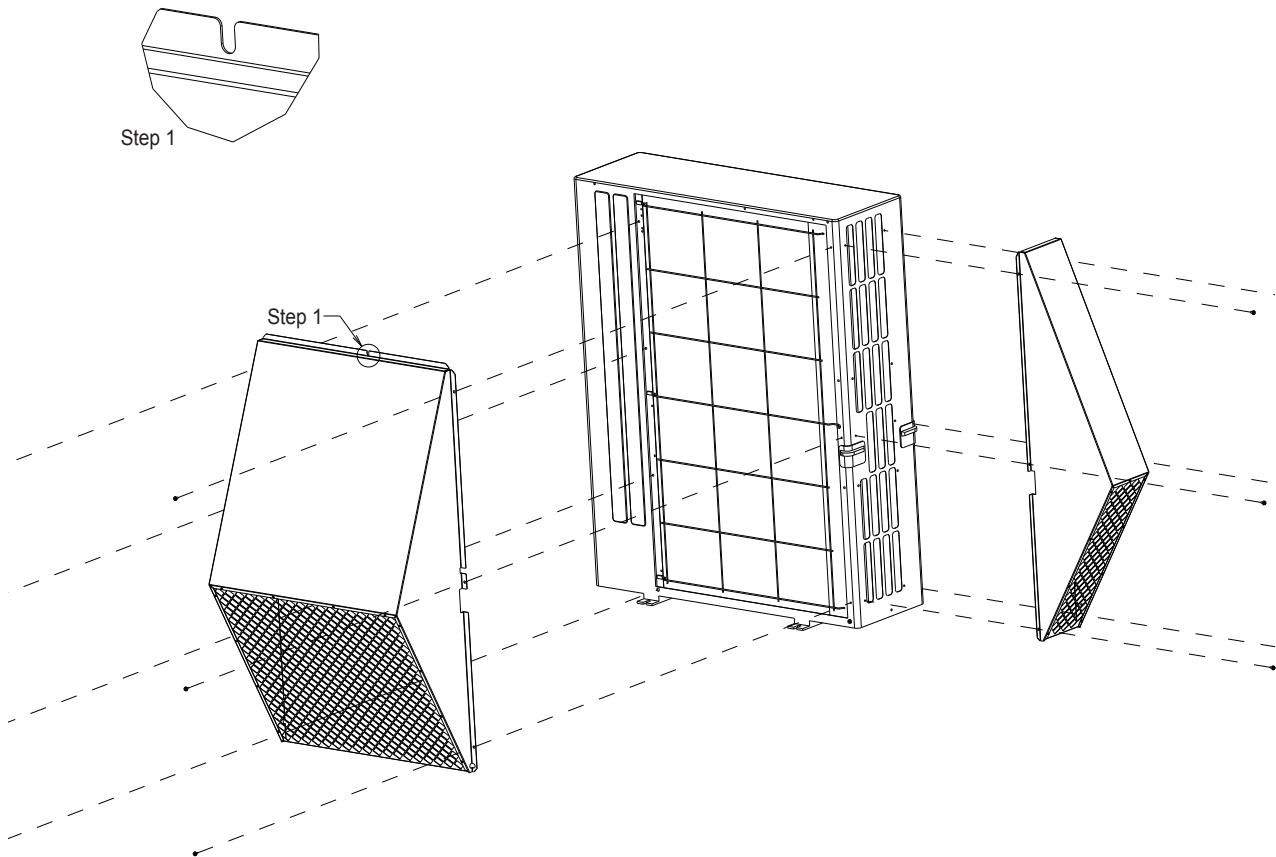

HG-A4

Step 1. Insert the right side lip of the hail guard between the right side of the plastic grill and the edge of the outdoor unit cabinet.

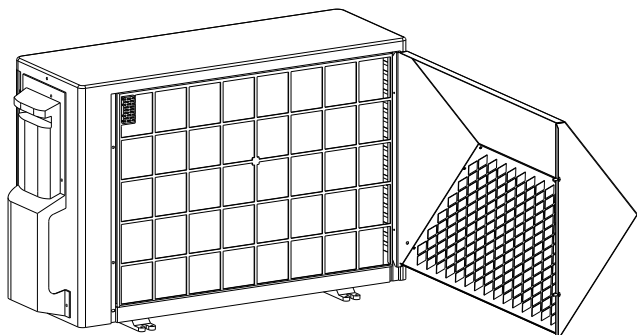

Step 2. Rotate the hail guard clockwise and loosely secure the left side with the existing screws.

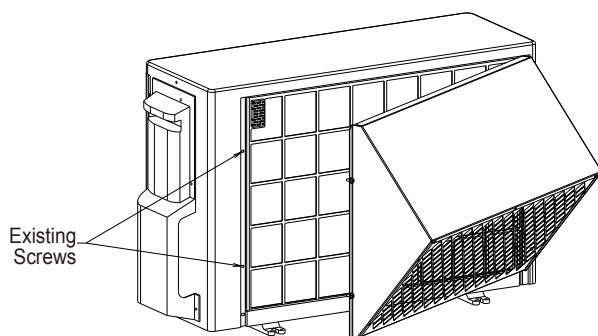

Step 3. Align the holes on the right side of the hail guard with the existing holes on the outdoor unit and secure with the screws provided.

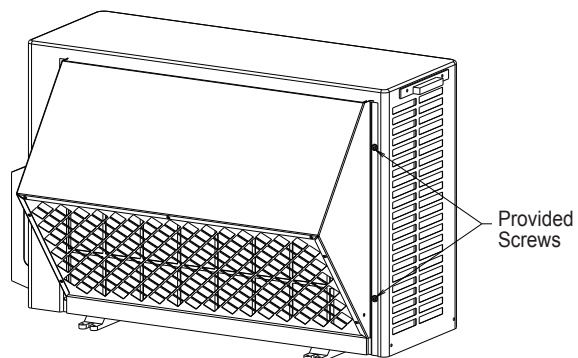

This product is designed and intended for use in the residential and light-commercial environment.

Please be sure to put the contact address/telephone number on this manual before handing it to the customer.

Manufactured for MITSUBISHI ELECTRIC US, INC.

www.mitsubishielectric-usa.com

Toll Free: 800-433-4822