

SHADOW

**High Efficiency Gas-Fired Hot Water
Direct Vent Condensing Boilers**

SUPPLEMENTAL INSTALLATION INSTRUCTIONS FOR ALL APPROVED VENT SYSTEMS (CPVC/PVC AND PPS)

NOTICE

This manual covers vent system installation only. It includes some vent options that are approved for use with this boiler but not shown in the boiler's installation manual. This supplement effectively replaces Section VII (venting) in Installation manual part number 106916-01. See Installation manual part number 106916-01 for all other aspects of installation, such as piping and wiring, as well for service and maintenance instructions.



WARNING

Improper installation, adjustment, alteration, service or maintenance can cause property damage, injury, or loss of life. For assistance or additional information, consult a qualified installer, service agency or the gas supplier. This boiler requires a special venting system. Read these instructions carefully before installing.



Intertek
9700609

**Velocity Boiler Works, LLC
P.O. Box 14818
3633 I Street
Philadelphia, PA 19134**

Table of Contents

VII. Venting	
A. General Vent System Design	3
B. Design Requirements Unique to Horizontal Twin Pipe Venting Systems	9
C. Design Requirements Unique to Vertical Venting Systems	15
D. Design Requirements Unique to Split Vent Systems	23
E. Assembly of CPVC/PVC Vent Systems	31
F. Assembly of DuraVent PolyPro Vent Systems	37
G. Assembly of Selkirk Polyflue Vent Systems	42
H. Assembly of Centrotherm InnoFlue Vent Systems	46
I. Condensate Trap and Drain	50
J. Removing An Existing Boiler From Common Chimney	51
Appendix A: Special Requirements For Side-Wall Vented Appliances In The Commonwealth of Massachusetts	52

VII Venting



- **Asphyxiation Hazard.** Failure to vent this boiler in accordance with these instructions could cause products of combustion to enter the building resulting in severe property damage, personal injury or death.
- Do not interchange vent systems or materials unless otherwise specified.
- The use of thermal insulation covering vent pipe and fittings is prohibited.
- Do not use a barometric damper, draft hood or vent damper with this boiler.
- When using the CPVC/PVC vent option, the use of CPVC is required when venting in vertical or horizontal chase ways.
- Any CPVC vent materials supplied with this boiler do not comply with B149.1.S1-07 and are not approved for use in Canadian jurisdictions that require vent systems be listed to ULC S636-2008. In these jurisdictions, vent this boiler using a listed ULC S636 Class IIB venting system.
- Do not locate vent termination where exposed to prevailing winds. Moisture and ice may form on surface around vent termination. To prevent deterioration, surface must be in good repair (sealed, painted, etc.).
- Do not locate air intake vent termination where chlorines, chlorofluorocarbons (CFC's), petroleum distillates, detergents, volatile vapors or other chemicals are present. Severe boiler corrosion and failure will result.
- The use of cellular core PVC (ASTM F891), cellular core CPVC or Radel (polyphenolsulfone) is prohibited.
- Do not locate vent termination under a deck.
- Do not reduce specified diameters of vent and combustion air piping.
- When installing vent pipe through chimney, as a chase, no other appliance can be vented into the chimney.
- Do not allow low spots in the vent where condensate may pool.

A. General Vent System Design

There are three basic ways to vent this boiler:

- **Horizontal (“Side Wall”) Twin Pipe Venting (Figure 7.0a)** - Vent system exits the building through an outside wall. Combustion air and flue gas are routed between the boiler and the terminal(s) using separate pipes for at least part of the way. A summary of Horizontal Twin Pipe venting options is shown in Table 7.5.
- **Vertical Twin Pipe Venting (Figure 7.0b)** - Vent system exits the building through a roof. Combustion air and flue gas are routed between the boiler and the terminal(s) using separate pipes for at least part of the way. A summary of Vertical Twin Pipe venting options is shown in Table 7.13
- **Split Venting (Figure 7.0c)** - Exhaust system exits the building through a roof, and combustion air is drawn from a terminal mounted on the side wall. A summary of split venting options is shown in Table 7.21

All of these systems are considered “direct vent” because the air for combustion is drawn directly from the outdoors into the boiler. One of the vent option columns in Tables 7.5, 7.13 or 7.21 must match the planned vent and air intake system exactly.

Design details applying to all vent systems are shown in this section. Observe all design requirements in this section, as well as those unique to the type of system being installed:

- B - Design Requirements Unique to Horizontal Twin Pipe Vent Systems
- C - Design Requirements Unique to Vertical Twin Pipe Vent systems
- D - Design Requirements Unique to Split Vent Systems

FIGURE 7.0 BASIC VENT OPTIONS

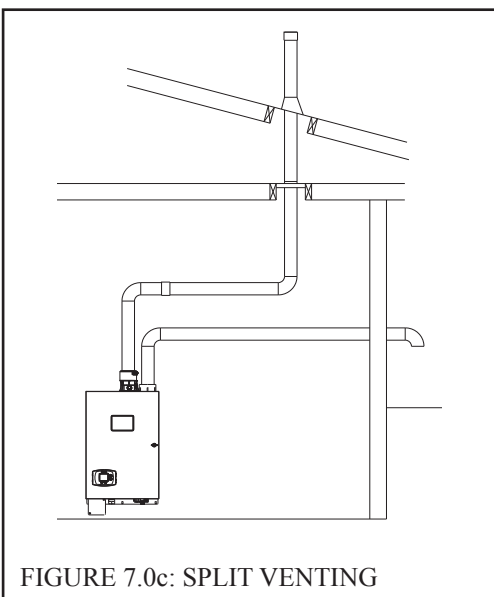
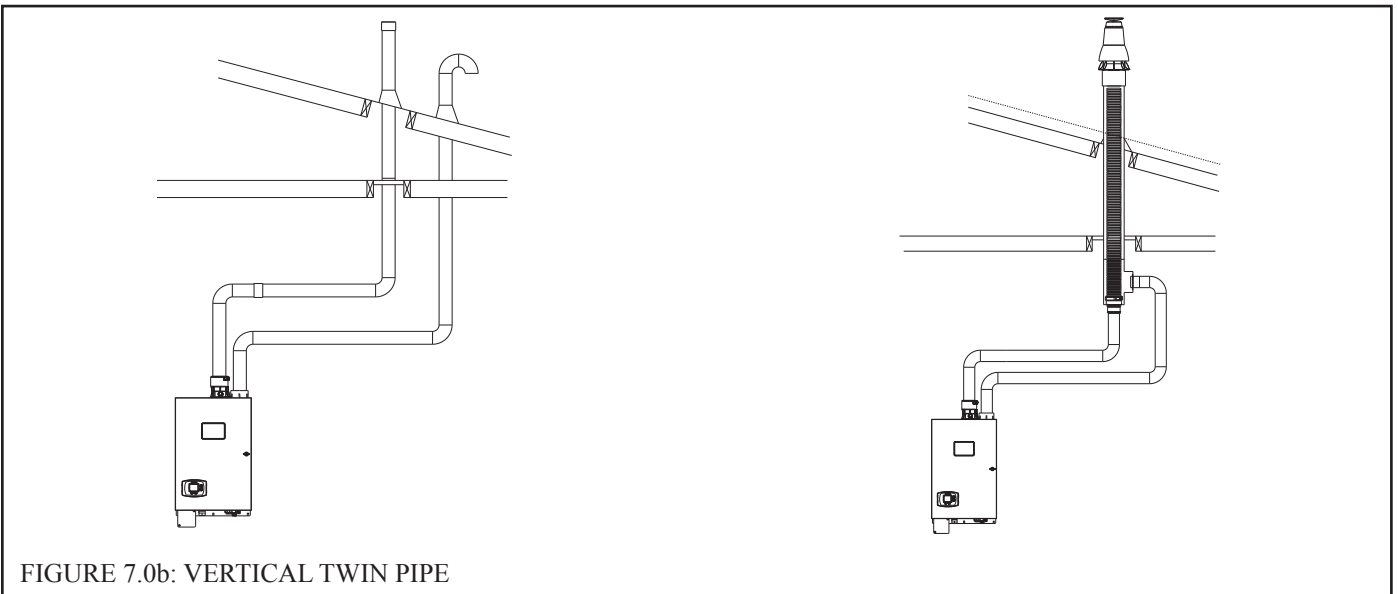
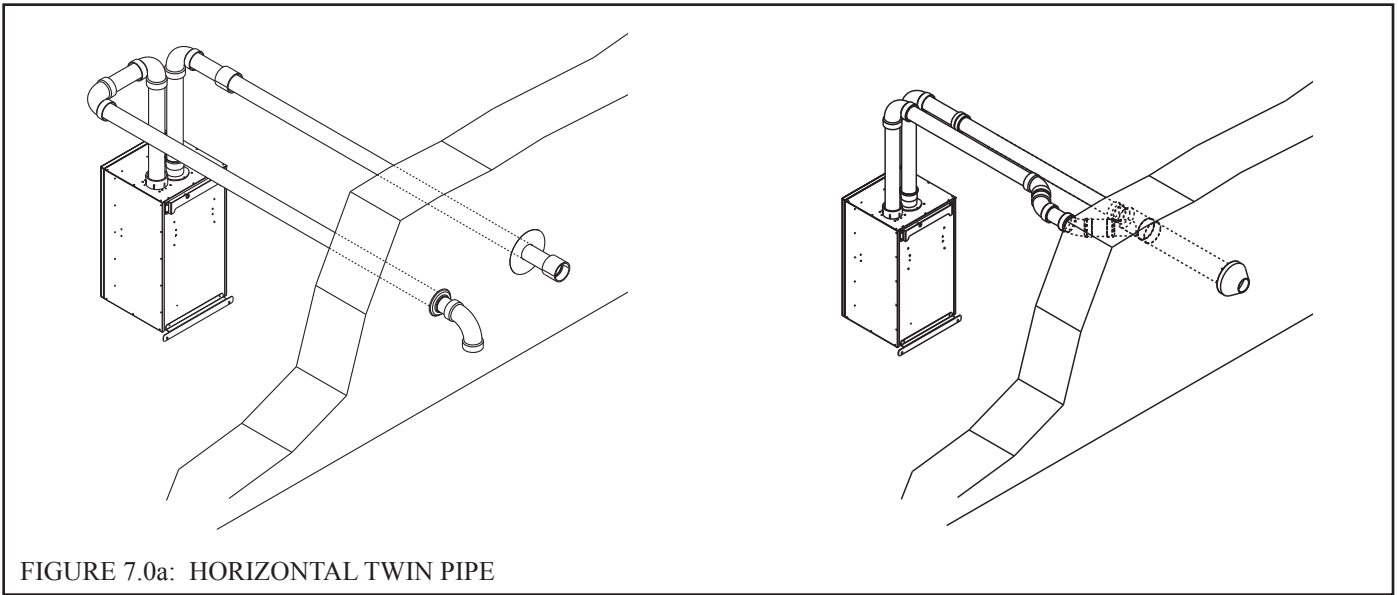

1. Approved Vent Systems and Materials – The following materials and vent systems may be used to vent this boiler:

- CPVC – Use only CPVC listed to ASTM F441. In Canada, this pipe must also be listed to ULC S636.
- PVC – PVC may be used only as permitted in this manual. All PVC must be listed to ASTM D2665. At least 30” of CPVC pipe, and at least one CPVC elbow, must be installed between the boiler’s vent connection and the PVC pipe. Use of foam core PVC is not permitted for venting. PVC vent pipe may not be used to vent this boiler in Canada.
- DuraVent PolyPro - ULC S636 listed polypropylene special gas vent system.
- Selkirk Polyflue - ULC S636 listed polypropylene special gas vent system.
- Centrotherm InnoFlue SW - ULC S636 listed polypropylene special gas vent system.

Use PVC and/or CPVC for the air intake system. PVC may be used for all air intake piping between the intake terminal and the boiler.

When CPVC and/or PVC pipe is used, it must be joined using primer and cement that is listed for use with the pipe material being joined (PVC, CPVC, or CPVC to PVC).

2. Vent Kits Available for Use with this Boiler – The following vent kits are available for CPVC/PVC vent systems installed with this boiler in the USA:

- 107039-01 - 2” CPVC/PVC Vent Kit
- 107039-02 – 3” CPVC/PVC Vent Kit

These kits include the following:

- (1) 30” CPVC Straight Pipe
- (1) 90 degree short bend CPVC Elbow
- (1) Straight PVC Coupling (for exhaust terminal)
- (1) 90 degree PVC Elbow (for intake termination)
- (2) Rodent screens

The CPVC Pipe and elbow supplied with these kits are not listed to ULC S636 and may not be used in Canada.

NOTICE

When 3” venting is used with the 80 or 100 models, a 2” x 3” CPVC Increaser and a short length of 2” CPVC pipe will be required to adapt from the 2” vent collar to the 3” components in the 107039-02 kit. These items are not included in the kit itself.

3. Maximum Vent and Air Intake Lengths - The maximum length of the vent air intake piping depends upon the vent option selected and the boiler size. See Tables 7.5, 7.13 or 7.21 for the maximum vent lengths. These maximum lengths apply to both the vent and intake piping (e.g. Option 1 may have up to 60ft of intake and 60ft of vent piping). For all vent systems, the lengths shown in Tables 7.5, 7.13 and 7.21 are in addition to the first 90° elbow. If more elbows are desired, the maximum allowable vent length must be reduced by the amount shown in Table 7.1 for each additional elbow used. Termination fittings are never counted.

It is recommended that all field supplied PVC or CPVC elbows be “1/4 Bend” (Sanitary 90° El) or “Long Sweep 1/4 Bend” type elbows (Figure 7.2). In this manual “sanitary” and “long sweep” elbows are treated as having the same equivalent length.

Example:

A 3” twin pipe horizontal CPVC/PVC vent system is planned for a horizontally vented 120MBH model which has the following components in the vent system:

- 1 ft CPVC Straight Pipe
- 90 CPVC Elbow (short bend)
- 1-1/2 ft CPVC Straight Pipe
- Coupling
- 10 ft PVC Straight Pipe
- 90 PVC Elbow (Sanitary Elbow Design)
- 15 ft PVC Straight Pipe
- PVC Coupling Terminal

The Vent Option #2 column in Table 7.5 describes a horizontal direct vent system using 3” CPVC and PVC pipe. From this column, we see that the boiler may have a vent length of up to 135ft. The first CPVC 90 degree elbow is not considered. From Table 7.1, we see that the equivalent length of the 90 PVC elbow is 4ft and that the equivalent length of the coupling is 0ft.

The total equivalent length of the planned venting system is therefore:

$$1\text{ft (Straight CPVC)} + 0\text{ft (first short bend CPVC 90 Elbow)} + 1.5\text{ft (Straight CPVC)} + 0\text{ft (Coupling)} + 10\text{ft (Straight PVC)} + 4\text{ft (PVC 90 Sanitary Elbow)} + 15\text{ft (Straight PVC)} + 0\text{ft (Coupling Terminal)} = 31.5\text{ft.}$$

Since Table 7.5 shows a maximum allowable vent length of 135ft, the planned vent system length is acceptable

The flex venting used on some of the Vertical Twin Pipe and Split Vent Options also reduces the maximum allowable vent length. See Sections VII-C or VII-D for details.

NOTICE

Do not exceed maximum vent/combustion air system length. Refer to Tables 7.1, 7.13 and 7.21 in this section for maximum vent/combustion air system length.

Use only vent and combustion air terminals and terminal locations shown in Tables 7.1, 7.13 and 7.21 and related Figures.

4. Minimum Vent and Air Intake Lengths - Observe the minimum vent lengths shown in Tables 7.1, 7.13 and 7.21.
5. Clearances to Combustibles - Maintain the following clearances from the vent system to combustible construction:
 - Vent - 1/4" (also observe clearances through both combustible and non-combustible walls - see 9 below)
 - Air Intake - 0"
 - Concentric Portion of Concentric Terminals - 0"
6. Pitch of Horizontal Vent Piping - Pitch all horizontal vent piping so that any condensate which forms in the piping will run towards the boiler.
 - Pitch CPVC/PVC vent piping 1/4" per foot.
 - Pitch polypropylene vent piping 5/8" per foot.

Les chaudières de catégories I, II et IV doivent présenter des tronçons horizontaux dont la pente montante est d'au moins 5/8 po par pied (52 mm/m) entre la chaudière et l'évent.

TABLE 7.1: VENT/ AIR INTAKE FITTING EQUIVALENT LENGTH

CPVC/PVC FITTING	EQUIVALENT LENGTH (ft)	POLYPRO, POLYFLUE OR INNOFLUE VENT FITTING	EQUIVALENT LENGTH (ft)
2" 90 ELBOW ("SANITARY BEND")	2.6	2" 90 ELBOW	4.5
3" 90 ELBOW ("SANITARY BEND")	4.0	3" 90 ELBOW	8.7
2" 90 ELBOW ("SHORT BEND")	6.0	2" 45 ELBOW	2.5
3" 90 ELBOW ("SHORT BEND")	10.0	3" 45 ELBOW	4.6
2" 45 ELBOW	1.5		
3" 45 ELBOW	2.0		
2" COUPLING	0.0		
3" COUPLING	0.0		

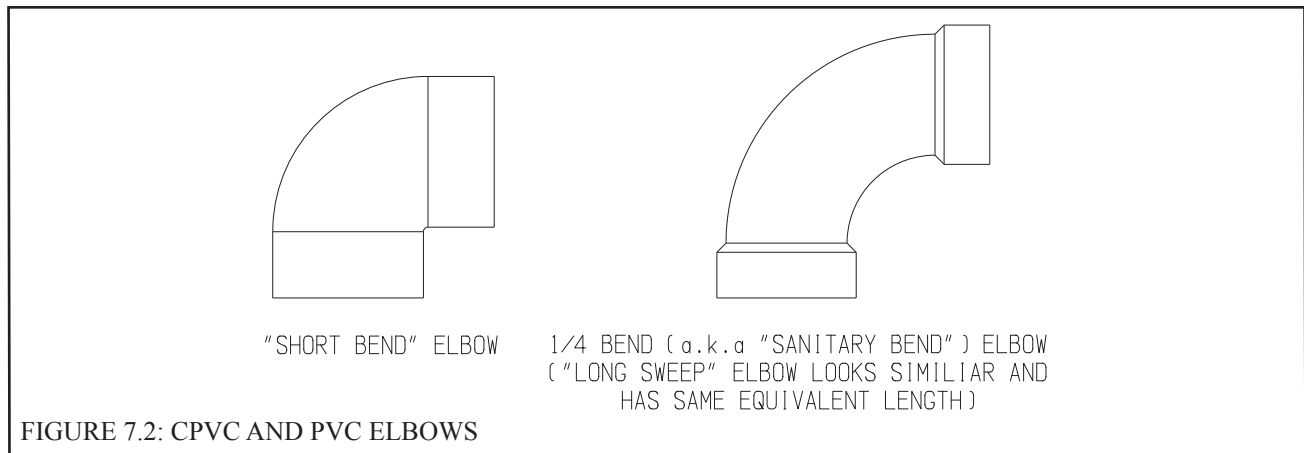

7. Supporting Pipe - Vertical and horizontal sections of pipe must be properly supported. Maximum support spacing is as follows:
- Support CPVC/PVC horizontally and vertically every 4 feet.
 - Support DuraVent Polypro horizontally near the female end of each straight section of pipe and vertically every 10 feet.
 - Support Centrotherm Innoflue horizontally every 39 inches with additional supports at elbows and vertically every 78".
 - Support 2" Selkirk Polyflue horizontally every 30". Support 3" Polyflue horizontally every 39". Support vertical runs of both 2" and 3" Polyflue every 16 ft.

Les instructions d'installation du système d'évacuation doivent préciser que les sections horizontales doivent être supportées pour prévenir le fléchissement. Les méthodes et les intervalles de support doivent être spécifiés. Les instructions doivent aussi indiquer les renseignements suivants:

- les chaudières de catégories II et IV doivent être installées de façon à empêcher l'accumulation de condensat: et
- si nécessaire, les chaudières de catégories II et IV doivent être pourvues de dispositifs d'évacuation du condensat.

8. Allowing for Thermal Expansion -

- Design the vent system to allow 3/8" of thermal expansion for every 10ft of CPVC/PVC pipe. The boiler will always act as an anchor to one end of the vent system. If at all possible, select and install hangers and wall thimbles so that the vent system can expand towards the terminal. When a straight run of pipe exceeds 20ft and must be restrained at both ends, an offset or expansion loop must be provided (Figures 7.3a, 7.3b). When a straight horizontal run of pipe exceeds 20ft and is restrained at one end with an elbow at the other, avoid putting a hanger or guide less than "Y" inches from the elbow in the adjoining straight section (Figure 7.3c). Thermal expansion fittings are not permitted.
- When properly assembled, expansion of Polypro, Polyflue and Innoflue vent systems is accommodated at the joints. See Part VII-F, G & H of this manual for details.

9. Running PVC Vent Pipe Inside Enclosures and Through Walls - PVC vent pipe must be installed in a manner that permits adequate air circulation around the outside of the pipe:

- Do not enclose PVC venting - Use CPVC in enclosed spaces, even if PVC is installed upstream.
- PVC venting may not be used to penetrate combustible or non-combustible walls unless all of the following conditions are met:
 - a. The wall penetration is at least 66 inches from the boiler as measured along the vent.
 - b. The wall is 12" thick or less
 - c. An airspace of at least that shown in Figure 7.4 is maintained around the OD of the vent.

If any of these conditions cannot be met, use CPVC for the wall penetration.

10. Vent Manufacturer's Instructions – The vent system manufacturer may have additional vent system design requirements. Read and follow the vent manufacturer's instructions in addition to those shown here. Where a conflict arises between the two sets of instructions, the more restrictive requirements shall govern.

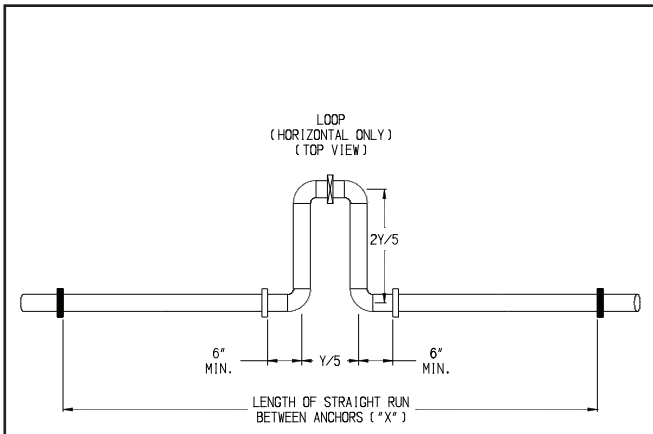

FIGURE 7.3a

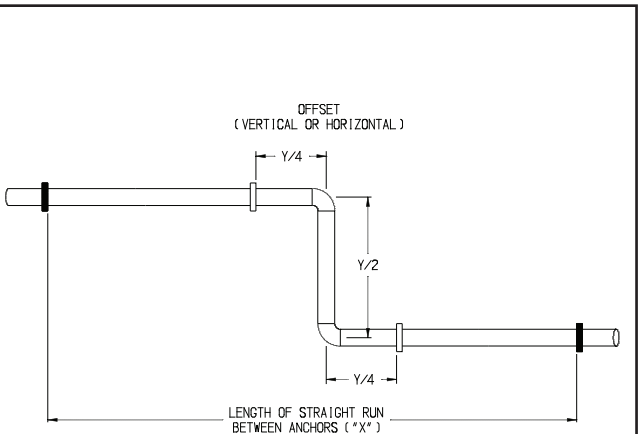

FIGURE 7.3b

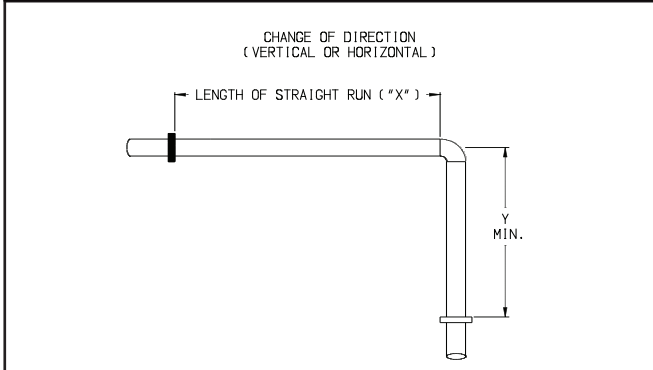

FIGURE 7.3c

PIPE DIA. (IN.)	"X" (FT.)	"Y" (IN.)
3	20	50
	30	61
	40	70
	50	79
	60	86
4	20	56
	30	69
	40	80
	50	89
	60	98

- KEY
- ANCHOR (RESTRICTS LINEAR MOVEMENT)
 - HANGER (ALLOWS LINEAR MOVEMENT)
 - CAN USE EITHER ANCHOR OR HANGER

FIGURE 7.3: EXPANSION LOOPS FOR CPVC/PVC PIPE

MAX. WALL THICKNESS ("T")	2"*	6"	12"
MINIMUM AIR SPACE AROUND PIPE ("C")	0"*	1"	1-3/4"

*WALL MUST BE OF NON-COMBUSTIBLE CONSTRUCTION

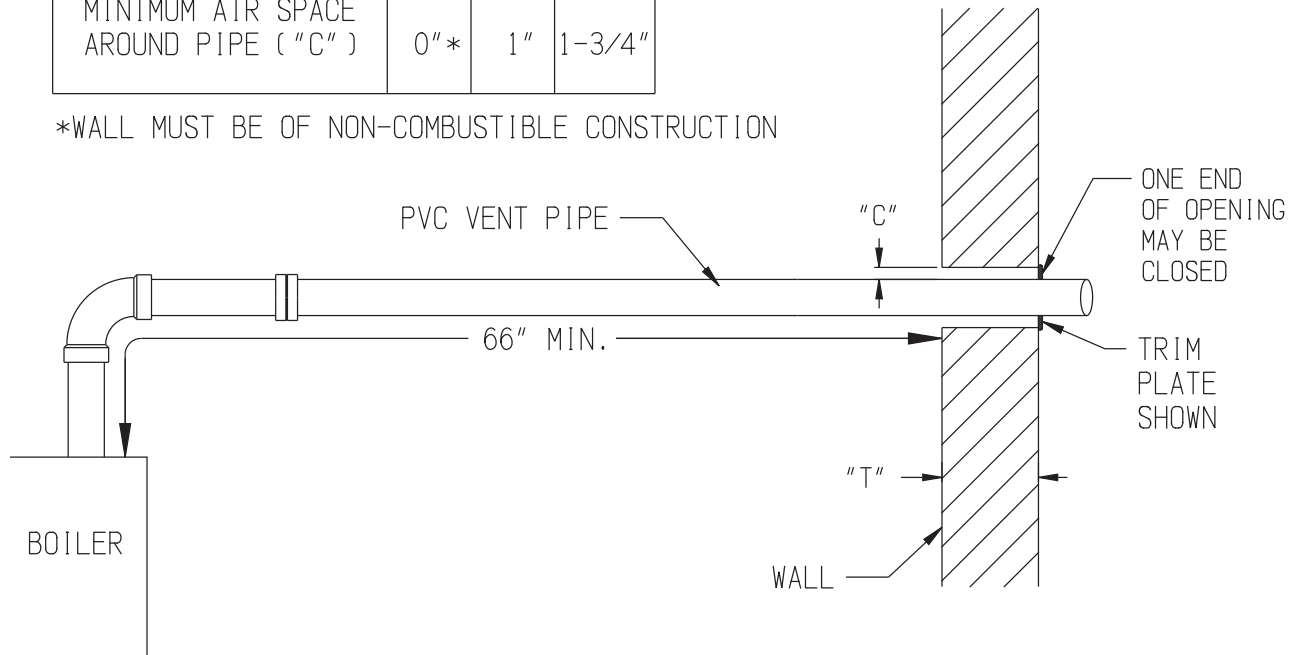

FIGURE 7.4: WALL PENETRATION CLEARANCES FOR PVC VENT PIPE

B. Design Requirements Unique to Horizontal Twin Pipe Venting Systems

Table 7.5 summarizes all horizontal twin pipe vent options. Illustrations of horizontal twin pipe vent systems are shown in Figures 7.6 – 7.10. In addition to the requirements in Part VII-A, observe the following design requirements:

1. Permitted Terminals for Horizontal Venting:

Terminal Option A: Fittings (Acceptable for Vent Options 1-8) – Vent terminates in a plain end (coupling for PVC, bell end for Polypro, Polyflue and plain end pipe for InnoFlue). Intake terminates in a PVC 90 sweep elbow pointing down. Outer edge of both terminals must be within 10” of the wall surface (Figures 7.6, 7.9). The section of DuraVent Polypro, Centrotherm InnoFlue or Selkirk Polyflue exposed to the outdoors must be UV resistant.

Use of rodent screens is generally recommended for both terminations. These can be fabricated from 2” x 2” (1/2” mesh) stainless steel screen and are installed as shown in Figure 7.28. Rodent screens (“bird guards”) for PolyPro, InnoFlue and Polyflue are as follows:

Size/Vent System	Rodent Screen (“Bird Guard”)
2” Polypro	DuraVent # 2PPS-BG
3” Polypro	DuraVent # 3PPS-BG
2” Polyflue	Selkirk # 2PF-HVST
3” Polyflue	Selkirk # 3PV-HVST
2” InnoFlue	Centrotherm # IASPP02
3” InnoFlue	Centrotherm # IASPP03

If necessary to achieve required clearance above grade, CPVC or CPVC/PVC vent systems may be terminated using fittings on snorkels as shown in Figure 7.12. When this is done, the equivalent length of all pipe on the exterior of the building, except for the terminal fittings themselves, must be counted when calculating the equivalent length. The maximum vertical run of the snorkel is 7 feet. Brace both the vent and inlet piping if required. Polypro, InnoFlue and Polyflue may not be snorkeled.

Terminal Option B: Iplex Low Profile Terminal (Acceptable for Vent Options 1,2) – This terminal is shown in Figure 7.7. If the terminal is oriented vertically (alternate orientation shown in Fig 7.7) the exhaust opening must be on the top as shown. See Part VII-E of this manual and the Iplex instructions provided with the terminal, for installation details.

Terminal Option C: Diversitech “Low Profile” Terminal (Acceptable for Vent Options 1,2) – This terminal is shown in Figure 7.7. If the terminal is oriented vertically (alternate orientation shown in Fig 7.7) the exhaust opening must be on the top as shown. See Part VII-E of this manual and the Diversitech instructions provided with the terminal, for installation details.

Terminal Option D: Iplex FGV Concentric Terminal (Acceptable for Vent Options 1,2) - This terminal is shown in Figure 7.8 and may be used with CPVC/PVC vent systems. This terminal is available in various lengths and in both PVC and CPVC. Terminals acceptable for use with these vent options are as follows:

Iplex PN	FGV Concentric Terminal Description
196005	2 x 16” PVC
196105	2 x 28” PVC
196125	2 x 40” PVC
196006	3 x 20” PVC
196106	3 x 32” PVC
196116	3 x 44” PVC
197107	3 x 32” CPVC
197117	3 x 44” CPVC

See Part VII-E of this manual and the Iplex instructions provided with the terminal, for installation details.

Terminal Option E: Diversitech Concentric Terminal (Acceptable for Vent Options 1,2) - This terminal is shown in Figure 7.8 and may be used with CPVC/PVC vent systems. See Part VII-E of this manual and the Diversitech instructions provided with the terminal, for installation details.

Terminal Option F: DuraVent PolyPro Concentric Terminal (Acceptable for Vent Options 3,4) - This terminal is shown in Figure 7.10 and may be used with DuraVent 2” or 3” PolyPro vent systems. See Part VII-F of this manual and the DuraVent instructions provided with the terminal, for installation details.

Table 7.5: Summary of Horizontal Twin Pipe Venting Options

Vent Option		1	2	3	4	5	6	7	8
Illustrated in Figure		7.6, 7.7, 7.8	7.6, 7.7, 7.8	7.9, 7.10	7.9, 7.10	7.9	7.9	7.9	7.9
Pipe Penetration through Structure	Vent	Wall	Wall	Wall	Wall	Wall	Wall	Wall	Wall
	Intake	Wall	Wall	Wall	Wall	Wall	Wall	Wall	Wall
Material	Vent	CPVC/PVC (Note 2)	CPVC/PVC (Note 2)	DuraVent PolyPro (Rigid)	DuraVent PolyPro (Rigid)	Selkirk Polyflue	Selkirk Polyflue	Centrotherm InnoFlue SW	Centrotherm InnoFlue SW
	Intake	PVC	PVC	PVC	PVC	PVC	PVC	PVC	PVC
Nominal Diameter	Vent	2"	3"	2"	3"	2"	3"	2"	3"
	Intake	2"	3"	2"	3"	2"	3"	2"	3"
Min Equivalent Vent Length:									
Models	080	12"	12"	12"	12"	12"	12"	12"	12"
	100	12"	12"	12"	12"	12"	12"	12"	12"
	120	Not Permitted	12"	Not Permitted	12"	Not Permitted	12"	Not Permitted	12"
	150		52"		52"		52"		
	180		52"		52"		52"		
Max Equivalent Vent Length (Note 1):									
Models	080	60ft	135ft	60ft	135ft	60ft	135ft	60ft	135ft
	100	60ft	135ft	60ft	135ft	60ft	135ft	60ft	135ft
	120	Not Permitted	135ft	Not Permitted	135ft	Not Permitted	135ft	Not Permitted	135ft
	150		135ft		135ft				
	180		135ft		135ft				
Terminal Option A (Fittings)	Vent	Coupling w Screen (Note 3)	Coupling w Screen (Note 3)	2PPS-12B or 2PPS-36B w Screen	3PPS-12B or 3PPS-36B w Screen	2PF-10UV or 2PF-39UV w Screen	3PF-10UV or 3PF-39UV w Screen	ISEP02 or ISEP0239 w Screen	ISEP03 or ISEP0339 w Screen
	Intake	Elbow w Screen (Note 3)	Elbow w Screen (Note 3)	Elbow w Screen	Elbow w Screen	Elbow w Screen	Elbow w Screen	Elbow w Screen	Elbow w Screen
Terminal Option B (Iplex Low Profile)		Iplex # 196984	Iplex #196985	Not Permitted	Not Permitted	Not Permitted	Not Permitted	Not Permitted	Not Permitted
Terminal Option C (Diversitech HVENT)		HVENT-2	HVENT-3	Not Permitted	Not Permitted	Not Permitted	Not Permitted	Not Permitted	Not Permitted
Terminal Option D (Iplex FGV Concentric)		Iplex 196105	Iplex 196006	Not Permitted	Not Permitted	Not Permitted	Not Permitted	Not Permitted	Not Permitted
Terminal Option E (Diversitech CVENT)		CVENT-2	CVENT-3	Not Permitted	Not Permitted	Not Permitted	Not Permitted	Not Permitted	Not Permitted
Terminal Option F (DuraVent Horizontal Concentric)		Not Permitted	Not Permitted	2PPS-HK	3PPS-HK	Not Permitted	Not Permitted	Not Permitted	Not Permitted

Notes:

- 1) Max vent lengths shown also apply to the intake. For example, Vent Option #1 may have up to 60ft of vent pipe and also up to 60 ft of intake pipe.
- 2) First 30" of vent and vent Elbow connected to boiler must be CPVC. Downstream vent pipe can be PVC except as noted in text.
- 3) PVC Terminal coupling and inlet elbow may be offset on snorkels as shown in Figure 7.12.

2. Horizontal Vent and Air Intake Terminal Location - Observe the following limitations on the vent terminal location (also see Figure 7.11). When locating a concentric terminal, observe the limitations outlined below for “vent terminals”.

- Vent terminal must be at least 1 foot from any door, window, or gravity inlet into the building.
- When Terminal Option A (fittings) are used, maintain the correct clearance and orientation between the intake and exhaust terminals. The recommended horizontal spacing between inlet and exhaust terminals is 36”, however this spacing may be reduced to 12” (center-to-center) if necessary. The elevation of the exhaust terminal must be at, or above, that of the intake terminal. The 12” minimum horizontal spacing must be maintained regardless of the vertical separation between the intake and exhaust terminals. Both terminals must be located on the same wall.
- The bottom of all terminals must be at least 12” above the normal snow line. In no case should they be less than 12” above grade level.
- The bottom of the vent terminal must be at least 7 feet above a public walkway.
- Do not install the vent terminal directly over windows or doors.
- The bottom of the vent terminal must be at least 3 feet above any forced air inlet located within 10 feet.
- USA Only: A clearance of at least 4 feet horizontally must be maintained between the vent terminal and gas meters, electric meters, regulators, and relief equipment. Do not install vent terminal over this equipment. In Canada, refer to B149.1 Installation Code for clearance to meters, regulators and relief equipment.
- Do not locate the vent terminal under decks or similar structures.
- Top of terminal must be at least 60” below ventilated eaves, soffits and other overhangs. In no case may the overhang depth exceed 36”. Where permitted by the authority having jurisdiction and local experience, the terminal may be located closer to unventilated soffits. The minimum vertical separation depends upon the depth of the soffit. See Figure 7.11 for details.
- Vent terminal must be at least 6 feet from an inside corner.
- Under certain conditions, water in the flue gas may condense, and possibly freeze, on objects around the vent terminal including on the structure itself. If these objects are subject to damage by flue gas condensate, they should be moved or protected.
- Install the vent and air intake terminals on a wall away from the prevailing wind. Reliable operation of this boiler cannot be guaranteed if these terminals are subjected to winds in excess of 40 mph.
- Air intake terminal must not terminate in areas that might contain combustion air contaminants, such as near swimming pools.

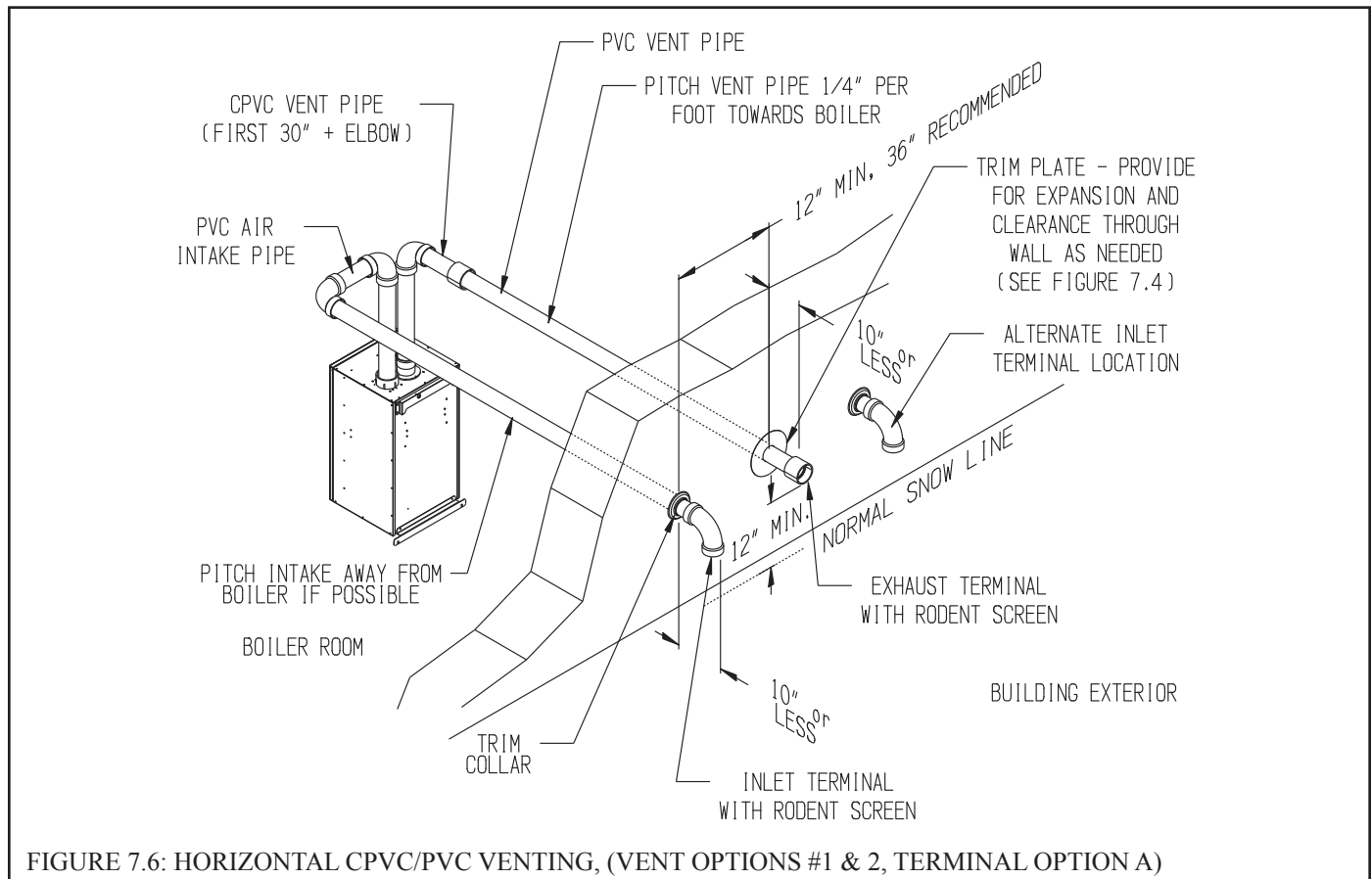

FIGURE 7.6: HORIZONTAL CPVC/PVC VENTING, (VENT OPTIONS #1 & 2, TERMINAL OPTION A)

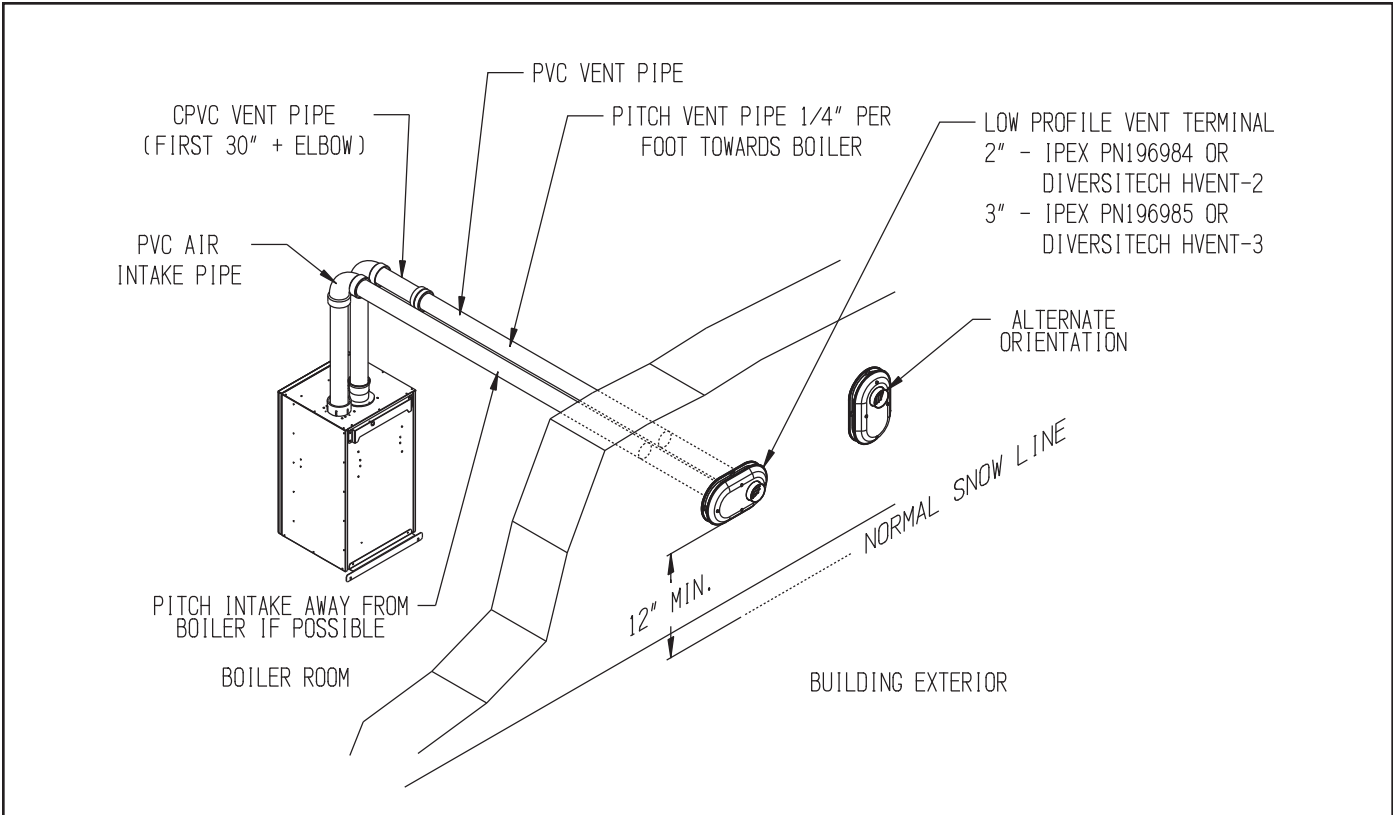

FIGURE 7.7: HORIZONTAL CPVC/PVC VENTING WITH LOW PROFILE TERMINAL,
(VENT OPTIONS #1 & 2, TERMINAL OPTIONS B & C)

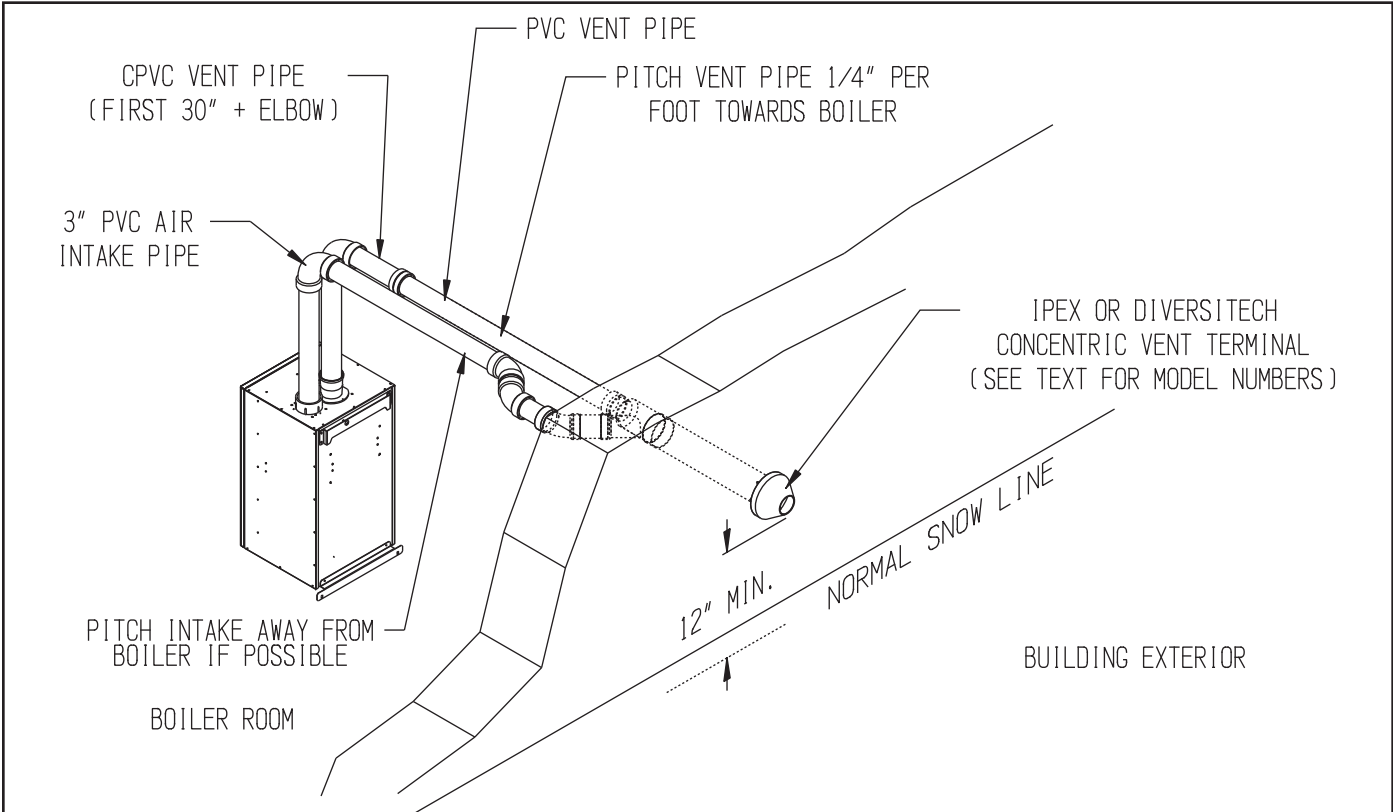

FIGURE 7.8: HORIZONTAL CPVC/PVC WITH CONCENTRIC VENT TERMINAL,
(VENT OPTIONS #1 & 2, TERMINAL OPTIONS D & E)

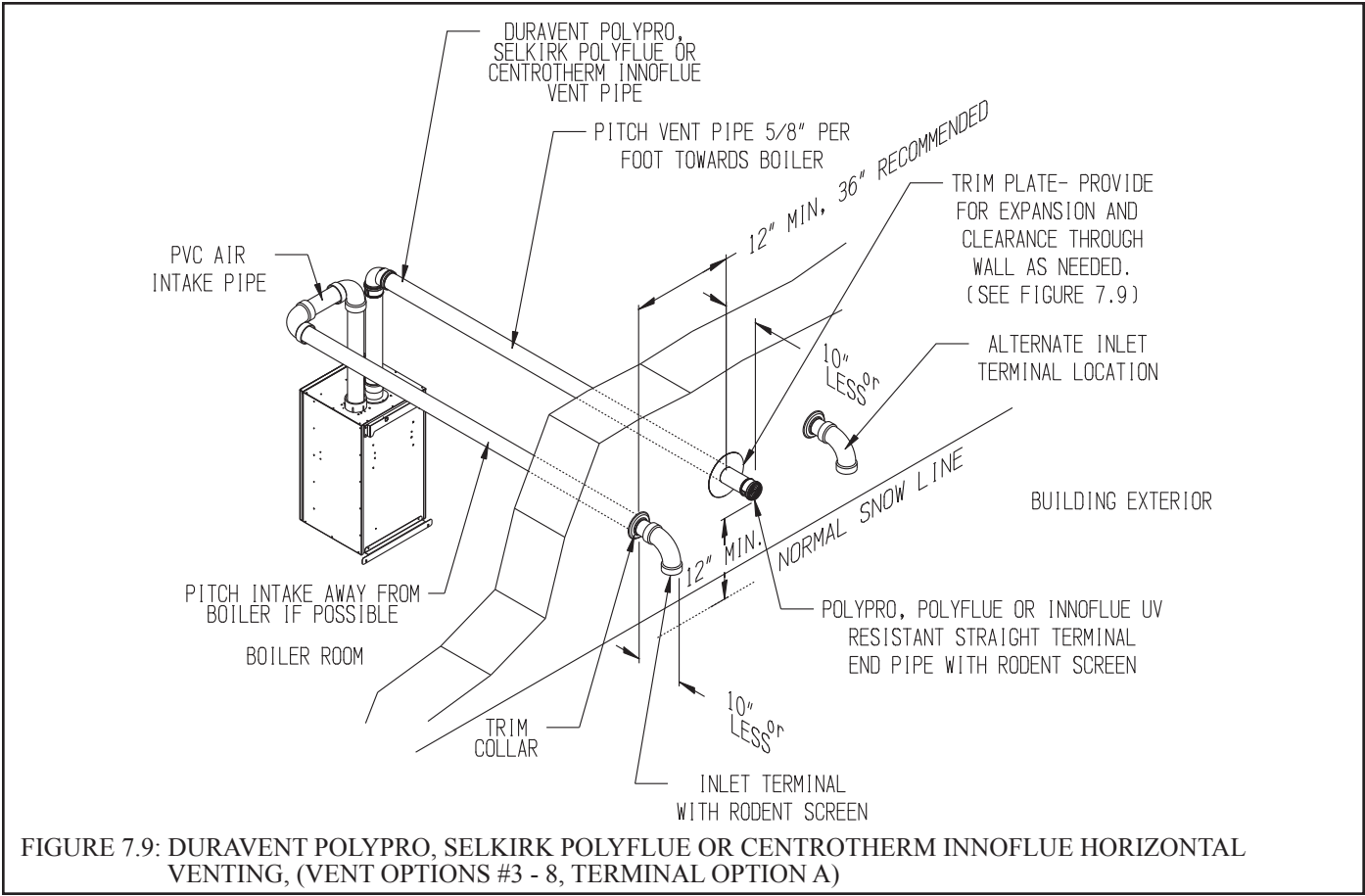

FIGURE 7.9: DURAVENT POLYPRO, SELKIRK POLYFLUE OR CENTROTHERM INNOFLUE HORIZONTAL VENTING, (VENT OPTIONS #3 - 8, TERMINAL OPTION A)

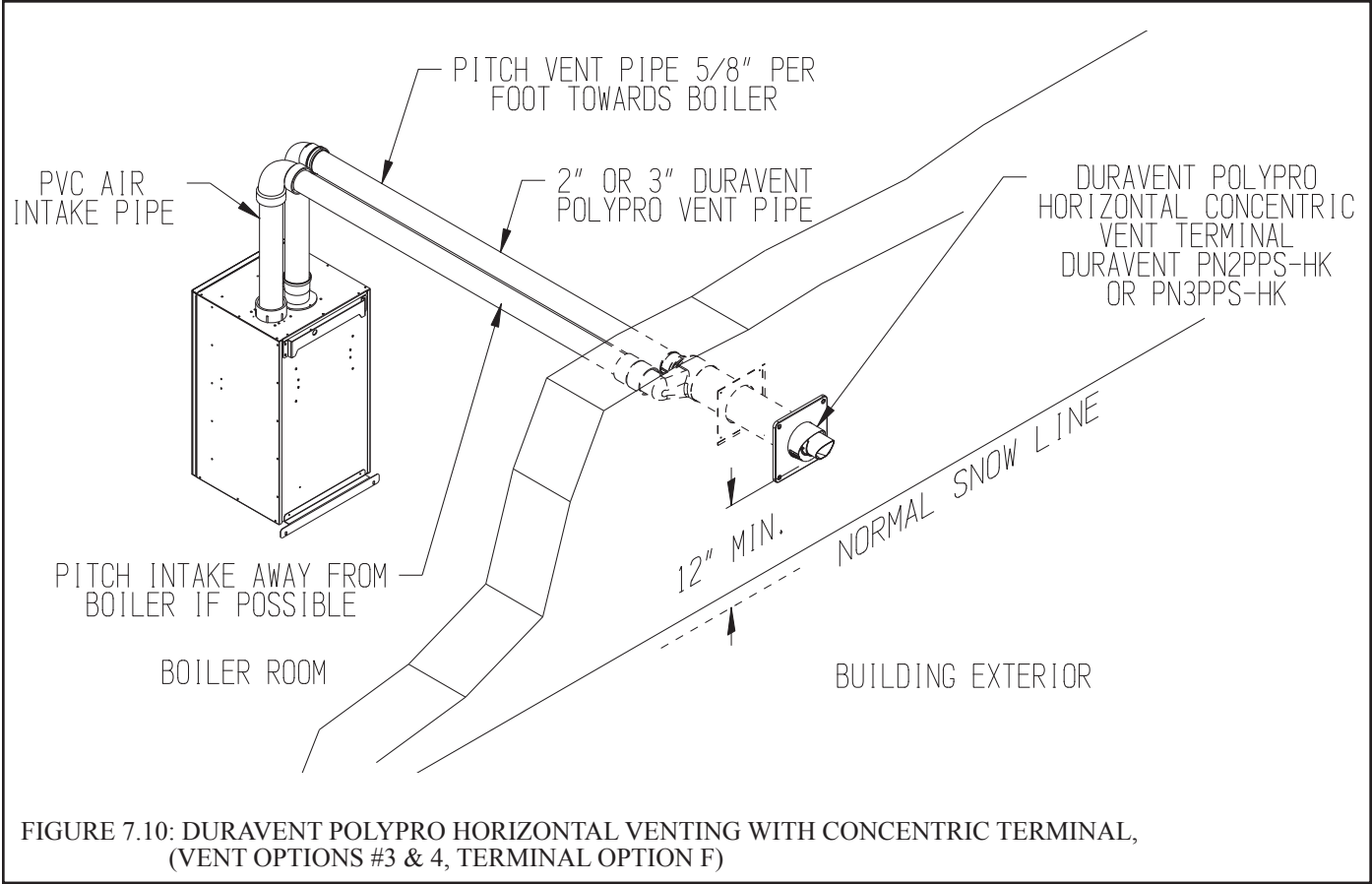
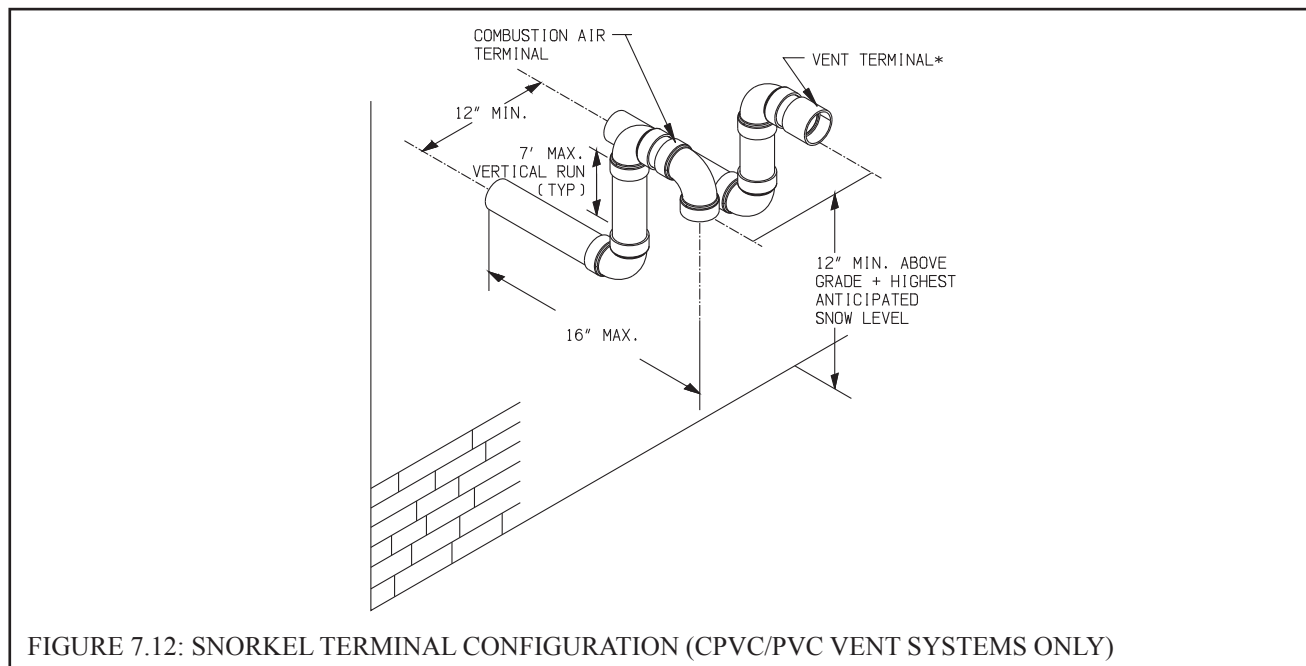

FIGURE 7.10: DURAVENT POLYPRO HORIZONTAL VENTING WITH CONCENTRIC TERMINAL, (VENT OPTIONS #3 & 4, TERMINAL OPTION F)



C. Design Requirements Unique to Vertical Venting Systems

Table 7.13a summarizes all vertical twin pipe vent options. Table 7.13.b summarizes vent options in which an abandoned B-vent chimney is used both as a chase for the vent pipe and as a conduit for combustion air.

In addition to the requirements in Part VII-A, observe the following design requirements:

1. Permitted Terminals for Vertical Venting

Terminal Option H: Fittings (Acceptable for Vent Options 10-17) – Vent terminates in a plain end (coupling for PVC, bell end for Polypro, Polyflue and plain end pipe for InnoFlue). Intake terminates in a PVC 180 elbow pointing down (two sweep 90’s may be substituted). Observe the clearances from the roof, and normal snow line on the roof, shown in Figures 7.15 and 7.17. The section of Polypro, Polyflue or InnoFlue exposed to the outdoors must be UV resistant.

Use of rodent screens is generally recommended for both terminations. These can be fabricated from 2” x 2” (1/2” mesh) stainless steel screen and are installed as shown in Figure 7.29. Rodent screens (“bird guards”) for PolyPro, Polyflue and InnoFlue are as follows:

Size/Vent System	Rodent Screen (“Bird Guard”)
2” Polypro	DuraVent # 2PPS-BG
3” Polypro	DuraVent # 3PPS-BG
2” Polyflue	Selkirk # 2PF-HVST
3” Polyflue	Selkirk # 3PV-HVST
2” InnoFlue	Centrotherm # IASPP02
3” InnoFlue	Centrotherm # IASPP03

Terminal Option I: Ipex FGV Concentric Terminal (Acceptable for Vent Options 10 & 11) - This terminal is shown in Figure 7.16 and may be used with CPVC/PVC vent systems. Use a compatible roof flashing and storm collar in accordance with the Ipex instructions for this terminal. This terminal is available in various lengths and in both PVC and CPVC. Terminals acceptable for use with these vent options are as follows:

Ipex PN	FGV Concentric Terminal Description
196005	2 x 16” PVC
196105	2 x 28” PVC
196125	2 x 40” PVC
196006	3 x 20” PVC
196106	3 x 32” PVC
196116	3 x 44” PVC
197107	3 x 32” CPVC
197117	3 x 44” CPVC

See Part VII-E of this manual and the Ipex instructions provided with the terminal, for installation details.

Table 7.13a: Summary of Vertical Twin Pipe Venting Options

Option		10	11	12	13	14	15	16	17
Illustrated in Figure		7.15, 7.17	7.15, 7.17	7.17, 7.18	7.17, 7.18	7.17	7.17	7.17	7.17
Pipe Penetration through Structure	Vent	Roof	Roof	Roof	Roof	Roof	Roof	Roof	Roof
	Intake	Roof	Roof	Roof	Roof	Roof	Roof	Roof	Roof
Material	Vent	CPVC/ PVC (Note 2)	CPVC/ PVC (Note 2)	DuraVent PolyPro (Rigid)	DuraVent PolyPro (Rigid)	Selkirk Polyflue	Selkirk Polyflue	Centro- therm InnoFlue SW	Centro- therm InnoFlue SW
	Intake	PVC	PVC	PVC	PVC	PVC	PVC	PVC	PVC
Nominal Diameter	Vent	2"	3"	2"	3"	2"	3"	2"	3"
	Intake	2"	3"	2"	3"	2"	3"	2"	3"
Min Equivalent Vent Length:									
Models	080	12"	12"	12"	12"	12"	12"	12"	12"
	100	12"	12"	12"	12"	12"	12"	12"	12"
	120	Not Permitted	12"	Not Permitted	12"	Not Permitted	12"	Not Permitted	12"
	150		52"		52"		52"		
	180		52"		52"		52"		
Max Equivalent Vent Length (Note 1):									
Models	080	60ft	135ft	60ft	135ft	60ft	135ft	60ft	135ft
	100	60ft	135ft	60ft	135ft	60ft	135ft	60ft	135ft
	120	Not Permitted	135ft	Not Permitted	135ft	Not Permitted	135ft	Not Permitted	135ft
	150		135ft		135ft		135ft		
	180		135ft		135ft		135ft		
Terminal Option H (Fittings)	Vent	Coupling w Screen	Coupling w Screen	2PPS-12B or 2PPS-36B w Screen	3PPS-12B or 3PPS-36B w Screen	2PF-10UV or 2PF-39UV w Screen	3PF-10UV or 3PF-39UV w Screen	ISEP02 or ISEP0239 w Screen	ISEP03 or ISEP0339 w Screen
	Intake	180 Elbow w Screen	180 Elbow w Screen	180 Elbow w Screen	180 Elbow w Screen	180 Elbow w Screen	180 Elbow w Screen	180 Elbow w Screen	180 Elbow w Screen
Terminal Option I (Iplex FGV Concentric)		Iplex 196105 (Note 3)	Iplex 196006 (Note 3)	Not Permitted	Not Permitted	Not Permitted	Not Permitted	Not Permitted	Not Permitted
Terminal Option J (Diversitech CVENT Concentric)		CVENT-2	CVENT-3	Not Permitted	Not Permitted	Not Permitted	Not Permitted	Not Permitted	Not Permitted
Terminal Option K (DuraVent Vertical Concentric)		Not Permitted	Not Permitted	2PPS-VK	3PPS-VK	Not Permitted	Not Permitted	Not Permitted	Not Permitted

Notes:

- 1) Max vent lengths shown also apply to the intake. For example, Vent Option #1 may have up to 60ft of vent pipe and also up to 60 ft of intake pipe.
- 2) First 30" of vent and vent Elbow connected to boiler must be CPVC. Downstream vent pipe can be PVC except as noted in text.
- 3) Iplex FGV Concentric Terminal available in various lengths and also CPVC (see text).

All vertical terminals require compatible roof flashing and storm collars.

Table 7.13b: Summary of Vertical “B-Vent Air Chase” Vent Options
(B-Vent Chase MUST Be Sealed)

Option		18	19	20	21
Illustrated in Figure		7.19	7.19	7.20	7.20
Pipe Penetration Through Structure	Vent	Roof	Roof	Roof	Roof
	Intake	Roof	Roof	Roof	Roof
Material	Vent	DuraVent PolyPro (Rigid/Flex)	DuraVent PolyPro (Rigid/Flex)	Centrotherm InnoFlue SW/Flex	Centrotherm InnoFlue SW/Flex
	Intake	B Vent/PVC	B Vent/PVC	B Vent/PVC	B Vent/PVC
Nominal Diameter	Vent	2”	3”	2”	3”
	Intake	2” or 3”	3”	2” or 3”	3”
Min B Vent ID		5”	6”	5”	6”
Min Equivalent Vent Length:					
Models	080	36”	36”	36”	36”
	100	36”	36”	36”	36”
	120		36”		36”
	150		52”		52”
	180		52”		52”
Max Equivalent Vent Length (Note 1):					
Models	080	60ft	135ft	60ft	135ft
	100	60ft	135ft	60ft	135ft
	120		135ft		135ft
	150		135ft		135ft
	180		135ft		135ft
Vent Manufacturer’s PN for Flex Termination/Components Required		2PPS-VFT 2PPS-BV* 2PPS-FLEX**	3PPS-VFT 3PPS-BV* 3PPS-FLEX**	IFBK02**** IAWP02B	IFBK03**** IAWP03B

* Specify size of B vent (e.g. 2PPS-BV6 is for use with 6” B vent)

** Specify length in feet.

**** Specify Flex length and B-vent diameter (e.g. IFBK022505 includes 25ft of flex and used with 5” B vent)

Note 1: Max vent lengths shown also apply to the intake. Flex vent reduces the maximum allowable vent length. See equivalent lengths for flex vent shown in Table 7.14 and sizing example on page 27.

NOTICE

Vertical venting and combustion air roof penetrations (where applicable) require the use of roof flashing and storm collar, which are not supplied with the boiler, to prevent moisture from entering the structure.

Terminal Option J: Diversitech Concentric Terminal (Acceptable for Vent Options 10 & 11) - This terminal is shown in Figure 7.16 and may be used with CPVC/PVC vent systems. See Part VII-E of this manual and the Diversitech instructions provided with the terminal, for installation details.

Terminal Option K: DuraVent PolyPro Concentric Terminal (Acceptable for Vent Options 12, 13) - This terminal is shown in Figure 7.18 and may be used with DuraVent 2" or 3" PolyPro vent systems. Use a compatible DuraVent roof flashing and storm collar in accordance with the DuraVent instructions for this terminal. See Part VII-F of this manual and the DuraVent instructions provided with the terminal, for installation details.

2. Vertical Vent and Air Intake Location – Observe the following clearances from roof mounted terminals:

- Bottom of air intake opening must be at least 12" above the normal snow line anticipated on the roof.
- Exhaust opening must be at least 2ft above any portion of the roof or structure located within horizontally within 10ft.
- For terminal option H, maintain at least 12" of vertical separation between the exhaust and intake opening as shown in Figure 7.15 and 7.17.

3. Requirements for B-Vent Air Chase Options – Observe the following additional requirements when using an abandoned B-vent chimney as an air chase as described in Options #18-21. Also refer to Figures 7.19 & 7.20.

- B vent must be clean and in good condition.
- Use of flex polypropylene outside of B-vent chimney is not permitted.
- All joints and seams in the B-vent must be sealed with RTV. If these seams are not accessible, vent options 18-21 cannot be used while complying with the National Fuel Gas Code (as an alternative, the B-vent chimney can be used as a chase for the vent pipe while combustion air is piped from an outside wall - see Part VII-D for additional details).
- All venting is polypropylene supplied by the vent manufacturer shown in Table 7.13b. The portion of this venting within the B-vent is flexible.
- All flex pipe must be installed vertically. Up to two offsets (four bends) may be made in the vertical run of flex pipe. Bends used to make these offsets may not exceed 45 degrees.
- Because the flex pipe is corrugated, it has a higher pressure drop than the rigid pipe used elsewhere in the vent system. Equivalent lengths for flex venting are shown in Table 7.14. Reduce the maximum allowable vent length shown in Table 7.13b by this equivalent length for each foot of flex pipe used, as well as for each elbow in addition to the first. The termination is not counted. If offsets (described above) are present, the equivalent length of the bends in these offsets can also be ignored.

Example: A 100MBH model is to be installed as using Vent Option 18 as shown in Figure 7.19. The following components are used:

Vent:

2" DuraVent Poly-Pro (Rigid) – 4ft

2" DuraVent Poly-Pro Flex – 20ft

Poly-Pro elbows – 2

DuraVent 2PPS-VFT Terminal (exhaust side)

Intake:

2" PVC – 6ft

2" PVC Sweep 90 – 3

Turn in B vent Tee

Straight B-vent (5" or larger) containing flex vent – 20ft

DuraVent 2PPS-VFT Terminal (intake side)

Vent Equivalent length – First elbow is ignored. The terminal is also ignored. From Table 7.14, the equivalent length of 2" DuraVent Poly-Pro Flex is 2.0ft. From Table 7.1 the equivalent length of the second 90 elbow is 4.5ft. The equivalent length of the vent system is therefore:

$$4 + 4.5 + (20 \times 2.0) = 48.5ft.$$

Since Vent Option 18 shows a max vent length of 60ft, the planned vent length of OK.

Intake Equivalent length - First elbow and the turn in the B vent tee are ignored, leaving two sweep 90 elbows that must be counted. From Table 7.1, the equivalent length of each of these elbows is 2.6ft. From Table 7.14 the equivalent length of the B vent containing flex is 1.0ft. Equivalent length of the intake system is therefore:

$$(2 \times 2.6) + 6 + (20 \times 1.0) = 31.2ft.$$

Since this is less than 60ft, the planned intake length is OK.

Table 7.14: Equivalent Length of Flex Pipe

	Equivalent Length (ft)
Flex Vent (1 ft):	
2" DuraVent PolyPro Flex	2.0 ft
2" Centrotherm Innoflue Flex	2.0 ft
2" Selkirk Polyflue	2.0 ft
3" DuraVent PolyPro Flex	2.0 ft
3" Centrotherm Innoflue Flex	2.3 ft
3" Selkirk Polyflue	2.3 ft
B-Vent Air Chase (1ft):	
2" Flex Vent in 5" (or larger) B-Vent	1.0 ft
3" Flex Vent in 6" (or larger) B-Vent	1.0 ft

Note: Up to four 45 degree bends may be made in flex pipe or air chase.
 These bends are not counted when figuring equivalent length.

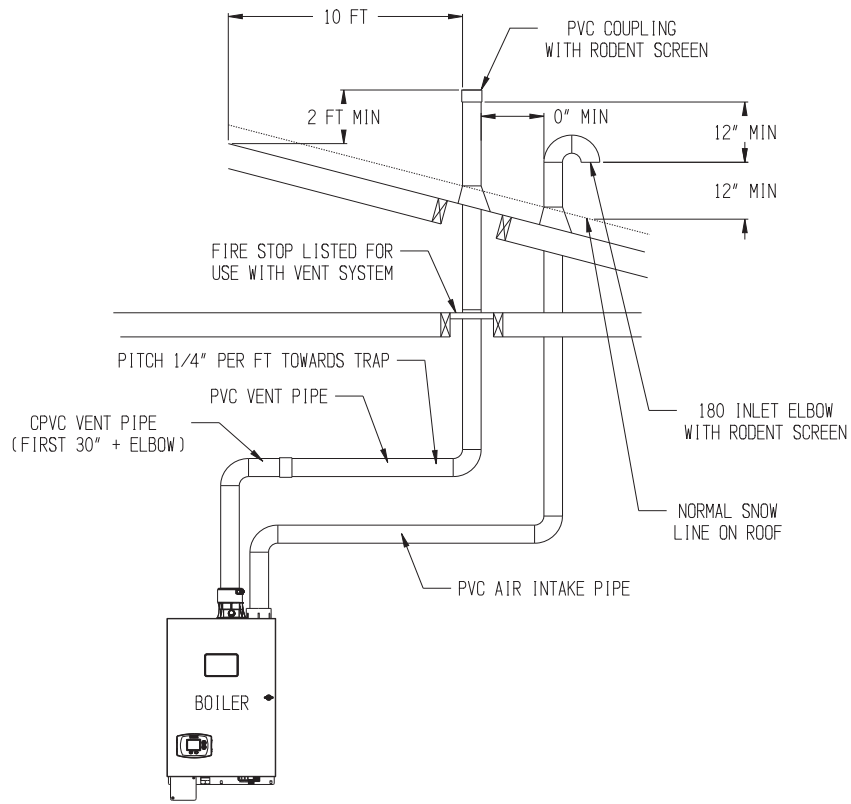

FIGURE 7.15: VERTICAL CPVC/PVC VENTING, (VENT OPTIONS 10 & 11, TERMINAL OPTION H)

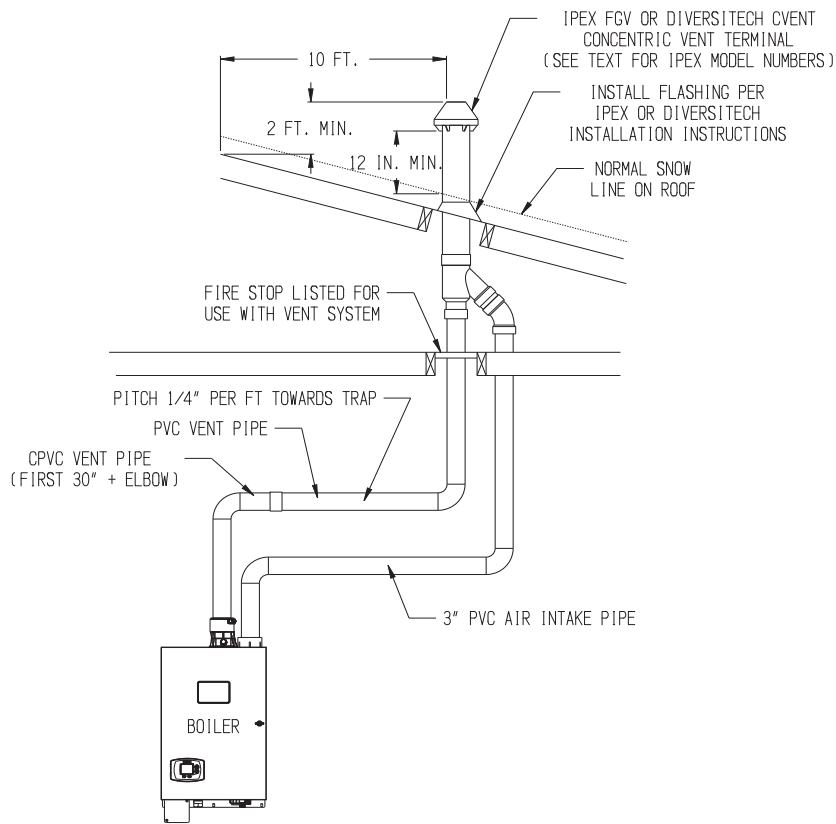

FIGURE 7.16: VERTICAL CPVC/PVC VENTING WITH IPEX CONCENTRIC VENT TERMINAL, (VENT OPTIONS #10 & 11, TERMINAL OPTIONS I, J)

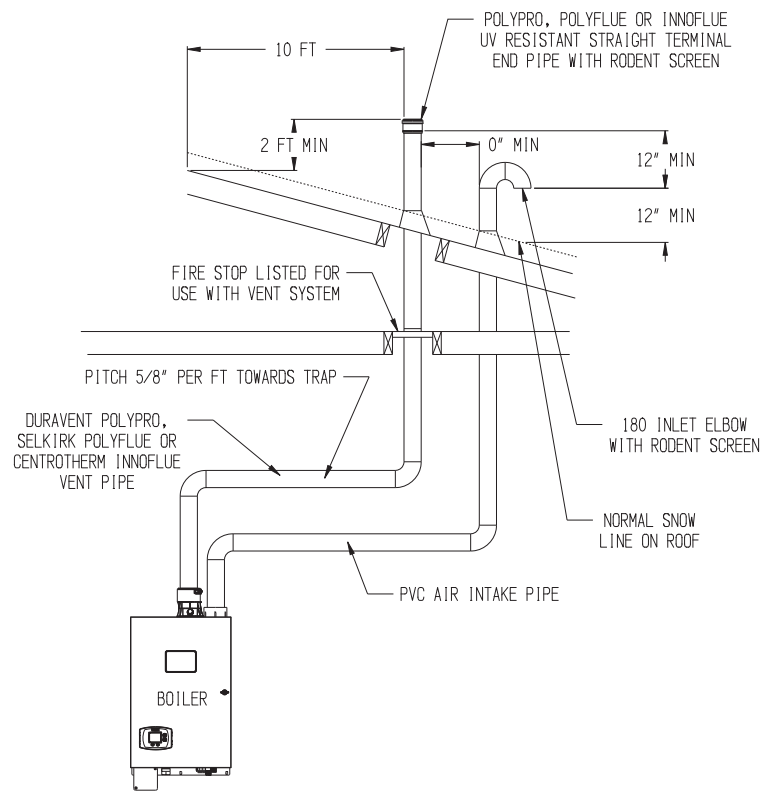

FIGURE 7.17: DURAVENT POLYPRO, SELKIRK POLYFLUE OR CENTROTHERM INNOFLUE VERTICAL SINGLE WALL PP VENTING, (VENT OPTIONS #12-17, TERMINAL OPTION H)

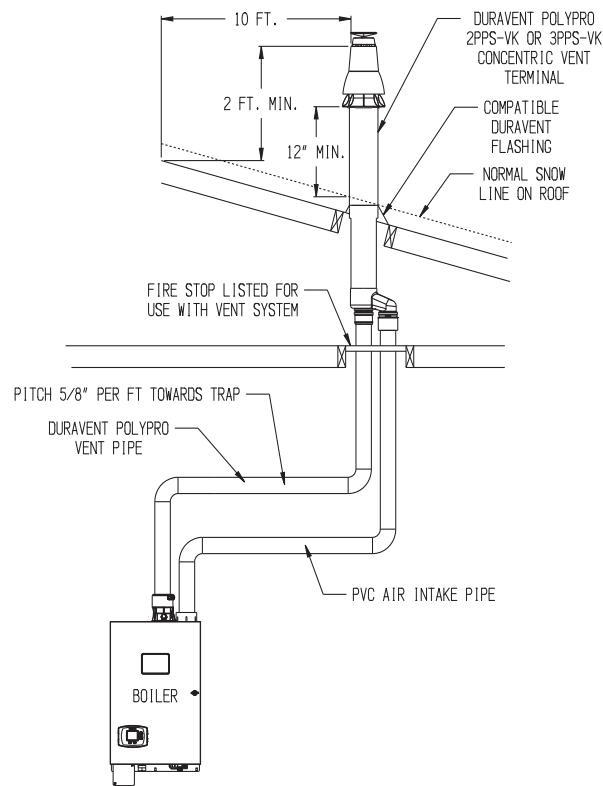

FIGURE 7.18: DURAVENT POLYPRO VERTICAL VENTING WITH CONCENTRIC TERMINAL, (VENT OPTIONS #12 & 13, TERMINAL OPTION K)

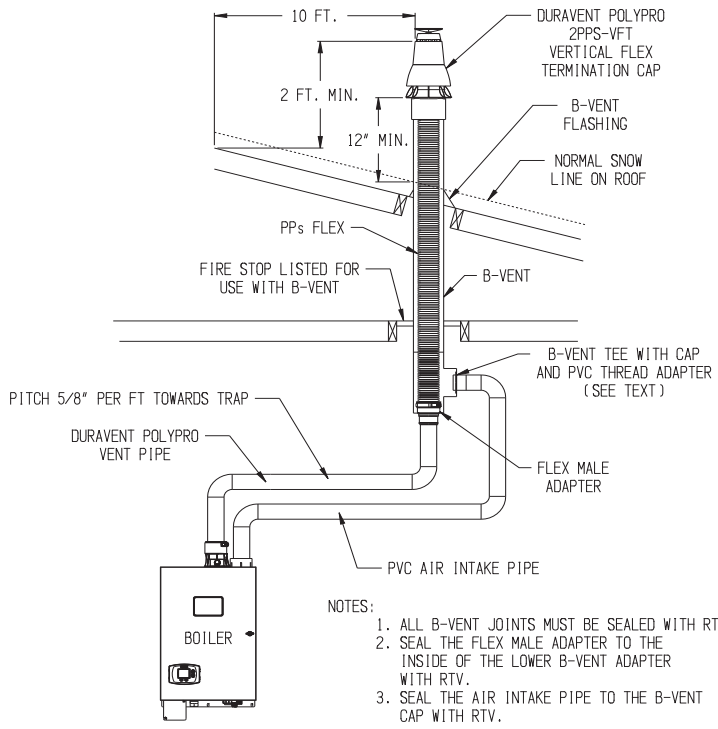

FIGURE 7.19: DURAVENT POLYPRO B-VENT AIR CHASE SYSTEM (VENT OPTIONS #18 & 19)

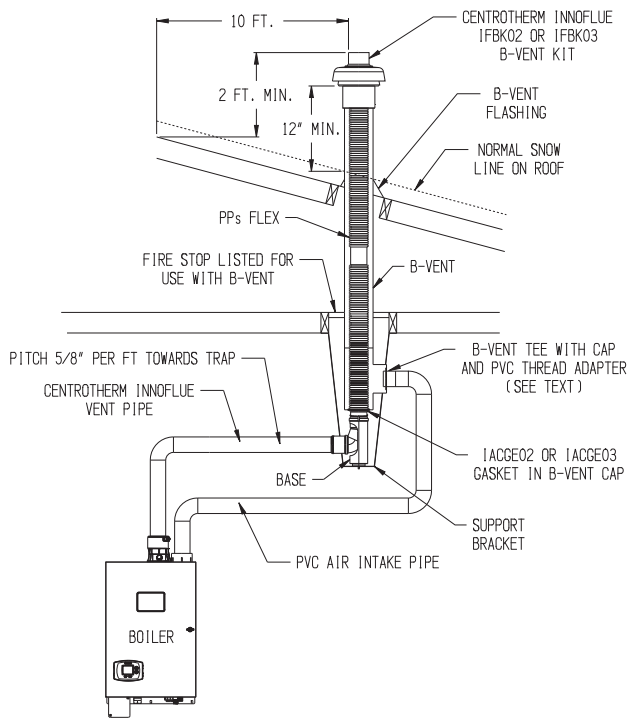

FIGURE 7.20: CENTROTHERM INNOFLUE B-VENT AIR CHASE SYSTEM (VENT OPTIONS #20 & 21)

D. Design Requirements Unique to Split Vent Systems

Table 7.21 summarizes all split vent options. Illustrations of split vent systems are shown in Figures 7.22, 7.23, and 7.24. In addition to the requirements in Part VII-A, observe the following design requirements:

1. Permitted Terminals for Split Venting:

Rigid Vent Systems (Vent Options 25-32) – Vent terminates in a plain end (coupling for PVC, bell end for Polypro, Polyflue, and plain end pipe for InnoFlue). Intake terminates in a PVC 90 sweep elbow pointing down. The section of Polypro, Polyflue or InnoFlue exposed to the outdoors must be UV resistant.

Use of a rodent screen is generally recommended for the vent termination. A rodent screen suitable for 3” PVC terminals is supplied with the boiler and is installed under the termination coupling as shown in Figure 7.28. If 2” CPVC is used, this screen can be cut to fit into the smaller fitting. Rodent screens (“bird guards”) for PolyPro, Polyflue and InnoFlue are as follows:

Size/Vent System	Rodent Screen (“Bird Guard”)
2” Polypro	DuraVent # 2PPS-BG
3” Polypro	DuraVent # 3PPS-BG
2” Polyflue	Selkirk #2PF-HVST
3” Polyflue	Selkirk #3PF-HVST
2” InnoFlue	Centrotherm # IASPP02
3” InnoFlue	Centrotherm # IASPP03

Flex Vent Terminals (Options 33-38) – The flex vent kits shown for options 33-38 include vent terminals that must be installed in accordance with the vent manufacturer’s instructions. Different terminals are used for Masonry and B-vent chimney chases.

Air Intake Terminals (Vent Options 25-38) - All split venting options shown in Tables 7.21 terminate in a PVC 90 sweep elbow pointing down. Use of a rodent screen is generally recommended for the intake termination. A rodent screen suitable for 3” PVC terminals is supplied with the boiler and is installed under the intake termination elbow coupling as shown in Figure 7.28. If 2” CPVC is used, this screen can be cut to fit into the smaller fitting.

2. Vent Terminal Location – Observe the following clearances from roof mounted vent terminals (also see Figures 7.22, 7.23, or 7.24):

- Bottom of terminal must be at least 12” above the normal snow line anticipated on the roof.
- Exhaust opening must be at least 2ft above any portion of the roof or structure located within horizontally within 10ft.

3. Horizontal Air Intake Terminal Location - Observe the following limitations on the intake terminal location (also see Figures 7.22, 7.23, or 7.24):

- The bottom of all terminals must be at least 12” above the normal snow line. In no case should they be less than 12” above grade level.
- If possible, install the intake terminal on a wall away from the prevailing wind. Reliable operation of this boiler cannot be guaranteed if the intake terminal is subjected to winds in excess of 40 mph.
- Air intake terminal must not terminate in areas that might contain combustion air contaminants, such as near swimming pools. See WARNING on page 12.

4. Use of abandoned chimneys as a vent chase (Options 33-38) – Vent options 33-38 permit flexible polypropylene venting to be routed to the roof using an abandoned masonry or B- vent chimney. In these applications combustion air is drawn horizontally from a wall terminal. See Figure 7.23 or 7.24. When using one of these vent options, observe the following requirements:

- When a masonry chimney containing multiple flues is used as a chase, ALL flues must be abandoned (Figure 7.26).
- Masonry or B vent chimney used as a chase must be structurally sound.
- Use of flex polypropylene outside of a masonry or B-vent chimney is not permitted unless allowed by the vent manufacturer and permitted by local codes.
- All venting is polypropylene supplied by the vent manufacturer shown in Table 7.21. The portion of this venting within the masonry or B-vent chimney is flexible.
- All flex pipe must be installed vertically. Up to two offsets (four bends) may be made in the vertical run of flex pipe. Bends used to make these offsets may not exceed 45 degrees (Figure 7.25).
- Because the flex pipe is corrugated, it has a higher pressure drop than the rigid pipe used elsewhere in the vent system. Equivalent lengths for flex venting are shown in Table 7.14. Reduce the maximum allowable vent length shown in Table 7.21 by this equivalent length for each foot of flex pipe used, as well as for each elbow in addition to the first. The first elbow and termination are not counted. If offsets (described above) are present, the equivalent length of the bends in these offsets can also be ignored.

Example: A 100MBH model is to be installed as using Vent Option 34 in a masonry chimney as shown in Figure 7.23. The following components are used:

Vent:

3" DuraVent Poly-Pro (Rigid) – 4ft

3" DuraVent Poly-Pro Flex – 30ft

Poly-Pro elbows – 2 (one at base of chimney and one above boiler)

DuraVent 3PPS-FK Terminal

Intake:

3" PVC – 6ft

3" PVC Sweep 90 – 2 (one above the boiler and one as an intake terminal)

Vent Equivalent length – First elbow is ignored. The terminal is also ignored. From Table 7.14, the equivalent length of 3" DuraVent Poly-Pro Flex is 2.0ft. From Table 7.1 the equivalent length of the second 90 elbow is 8.7ft. The equivalent length of the vent system is therefore:

$$4 + 8.7 + (30 \times 2.0) = 72.7\text{ft.}$$

Since Vent Option 34 shows a max vent length of 135ft, the planned vent length of OK.

Intake Equivalent length - First elbow and termination elbow are ignored, leaving just the straight pipe. Equivalent length of the intake system is therefore 6ft. Since this is less than 135ft, the planned intake length is OK.



WARNING

- **Flex Vent Options may only be used in unused chimneys**
- **When a Masonry chimney is used as a chase, ALL flues in that chimney must be unused.**

Failure to observe the above requirements could cause flue gas to enter the building, resulting in severe property damage, personal injury, or loss of life.

This page is intentionally left blank.

Table 7.21: Summary of Split Vent System Options

Option #		25	26	27	28	29	30
Illustrated in Figure		7.22	7.22	7.22	7.22	7.22	7.22
Pipe Penetration Through Structure	Vent	Roof	Roof	Roof	Roof	Roof	Roof
	Intake	Wall	Wall	Wall	Wall	Wall	Wall
Material	Vent	CPVC/PVC (Note 2)	CPVC/PVC (Note 2)	DuraVent PolyPro (Ridgid)	DuraVent PolyPro (Ridgid)	Selkirk Polyflue	Selkirk Polyflue
	Intake	PVC	PVC	PVC	PVC	PVC	PVC
Nominal Diameter	Vent	2"	3"	2"	3"	2"	3"
	Intake	2" or 3"	3"	2" or 3"	3"	2" or 3"	3"
Min Equivalent Vent Length:							
Models	080	48"	48"	48"	48"	48"	48"
	100	48"	48"	48"	48"	48"	48"
	120		48"		48"		48"
	150		52"		52"		52"
	180		52"		52"		52"
Max Equivalent Vent Length (Note 1):							
Models	080	60ft	135ft	60ft	135ft	60ft	135ft
	100	60ft	135ft	60ft	135ft	60ft	135ft
	120		135ft		135ft		135ft
	150		135ft		135ft		135ft
	180		135ft		135ft		135ft
Rigid Vent Terminals	Vent	Coupling w Screen	Coupling w Screen	2PPS-12B or 2PPS-36B w Screen	3PPS-12B or 3PPS-36B w Screen	2PF-10UV or 2PF-39UV w Screen	3PF-10UV or 3PF-39UV w Screen
	Intake	90 Elbow w Screen	90 Elbow w Screen	90 Elbow w Screen	90 Elbow w Screen	90 Elbow w Screen	90 Elbow w Screen
Flex Termination & Components (Masonry Chimney Chase) (Note 3)	Vent						
	Intake						
Flex Termination & Components (B-Vent Chimney Chase)	Vent						
	Intake						

* Specify size of B vent (e.g. 2PPS-BV6 is for use with 6" B vent)

** Specify length in feet.

**** Specify Flex length and B vent diameter (e.g. IFBK022505 includes 25ft of flex and used with 5" B vent)

Note 1: Max vent lengths shown also apply to the intake. Flex vent reduces the maximum allowable vent length.

See equivalent lengths for flex vent shown in Table 7.14 and sizing example on page 27.

Note 2: First 30" plus first exhaust elbow are CPVC.

Note 3: If masonry chimney contains flues in addition to that being used for chase, **ALL** must be unused.

Note 4: See Polyflue installation manual for gaskets, spacers and other required vent components.

All vertical terminals require compatible roof flashing and storm collars.

Table 7.21: Summary of Split Vent System Options (cont.)

31	32	33	34	35	36	37	38
7.22	7.22	7.23, 7.24	7.23, 7.24	7.23, 7.24	7.23, 7.24	7.23, 7.24	7.23, 7.24
Roof	Roof	Roof	Roof	Roof	Roof	Roof	Roof
Wall	Wall	Wall	Wall	Wall	Wall	Wall	Wall
Centrotherm InnoFlue SW	Centrotherm InnoFlue SW	DuraVent PolyPro (Rigid/Flex)	DuraVent PolyPro (Rigid/Flex)	Selkirk Polyflue (Rigid/Flex)	Selkirk Polyflue (Rigid/Flex)	Centrotherm Innoflue (Rigid/Flex)	Centrotherm Innoflue (Rigid/Flex)
PVC	PVC	PVC	PVC	PVC	PVC	PVC	PVC
2"	3"	2"	3"	2"	3"	2"	3"
2" or 3"	3"	2" or 3"	3"	2" or 3"	3"	2" or 3"	3"
Min Equivalent Vent Length:							
48"	48"	48"	48"	48"	48"	48"	48"
48"	48"	48"	48"	48"	48"	48"	48"
	48"		48"		48"		48"
	52"		52"		52"		52"
	52"		52"		52"		52"
Max Equivalent Vent Length (Note 1):							
60ft	135ft	60ft	135ft	60ft	135ft	60ft	135ft
60ft	135ft	60ft	135ft	60ft	135ft	60ft	135ft
	135ft		135ft		135ft		135ft
	135ft		135ft		135ft		135ft
	135ft		135ft		135ft		135ft
ISEP02 or ISEP0239 w Screen	ISEP03 or ISEP0339 w Screen						
90 Elbow w Screen	90 Elbow w Screen						
		2PPS-FK 2PPS-FLEX**	3PPS-FK 3PPS-FLEX**	2PF-FLEX-KIT 2PF-FLEX	3PF-FLEX-KIT 3PF-FLEX	IFCK02**	IFCK03**
		90 Elbow w Screen	90 Elbow w Screen	90 Elbow w Screen	90 Elbow w Screen	90 Elbow w Screen	90 Elbow w Screen
		2PPS-VFT 2PPS-BF* 2PPS-FLEX**	3PPS-VFT 3PPS-BF* 3PPS-FLEX**	2PF-10UV or 2PF-39UV w Screen 2PF-BVSC (Note 4)	3PF-10UV or 3PF-39UV w Screen 3PF-BVSC (Note 4)	IFBK02****	IFBK03****
		90 Elbow w Screen	90 Elbow w Screen	90 Elbow w Screen	90 Elbow w Screen	90 Elbow w Screen	90 Elbow w Screen

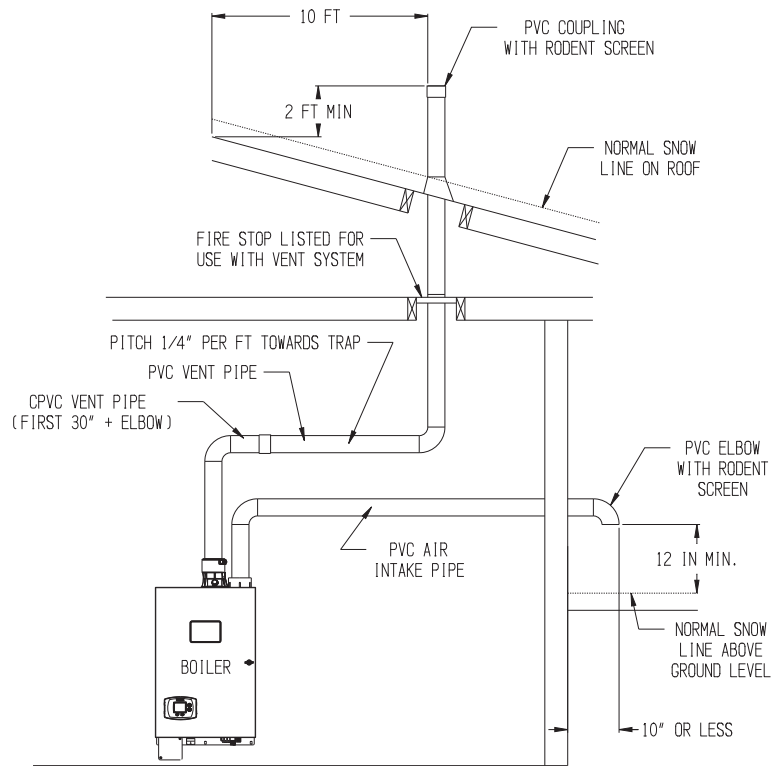

FIGURE 7.22: SPLIT RIGID VENT SYSTEM (VENT OPTIONS 25-32 - CPVC SYSTEM SHOWN IN ABOVE EXAMPLE)

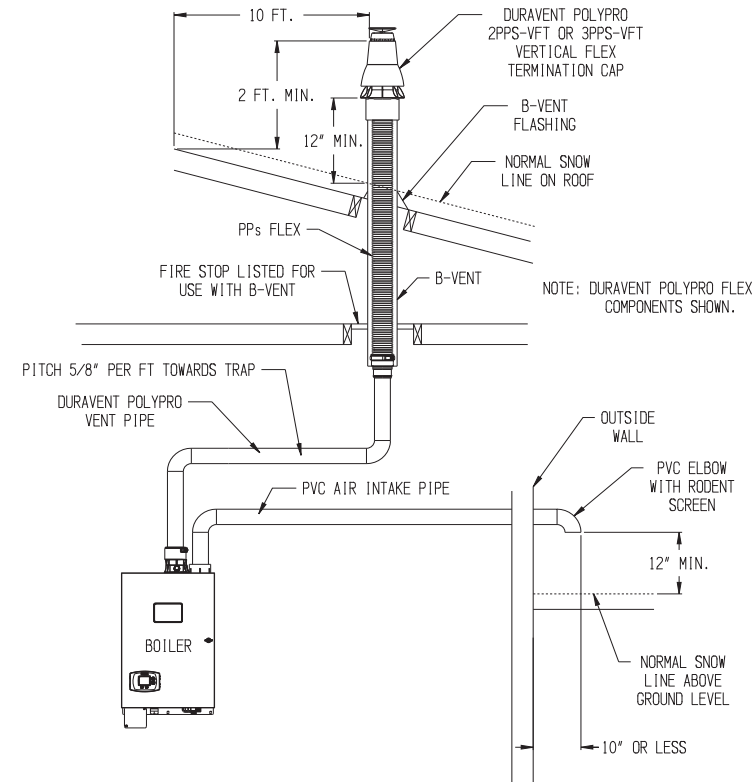

FIGURE 7.23: SPLIT VENT SYSTEM (FLEX IN B-VENT CHASE)(VENT OPTIONS 33-38)

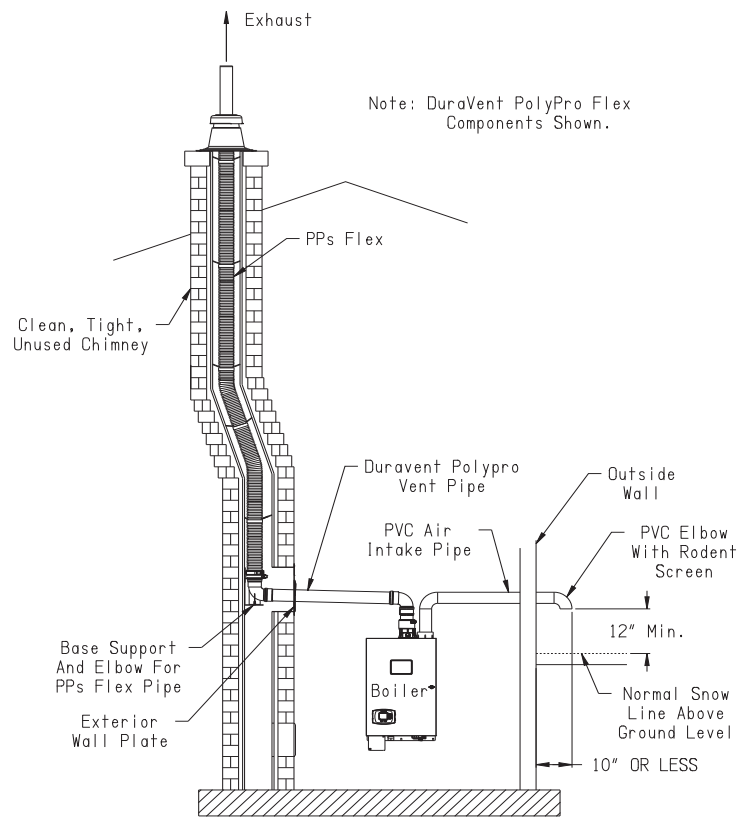
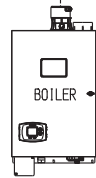

FIGURE 7.24: SPLIT VENT SYSTEM (FLEX IN ABANDONED MASONRY CHIMNEY)(VENT OPTIONS 33-38)

TRIM OLD LINER FLUSH WITH CROWN

45° MAX



CHIMNEY AND FOUNDATION ARE STRUCTURALLY SOUND

**Venting of Other Appliances
(Or Fireplace) into Chase or
Adjacent Flues Prohibited!**

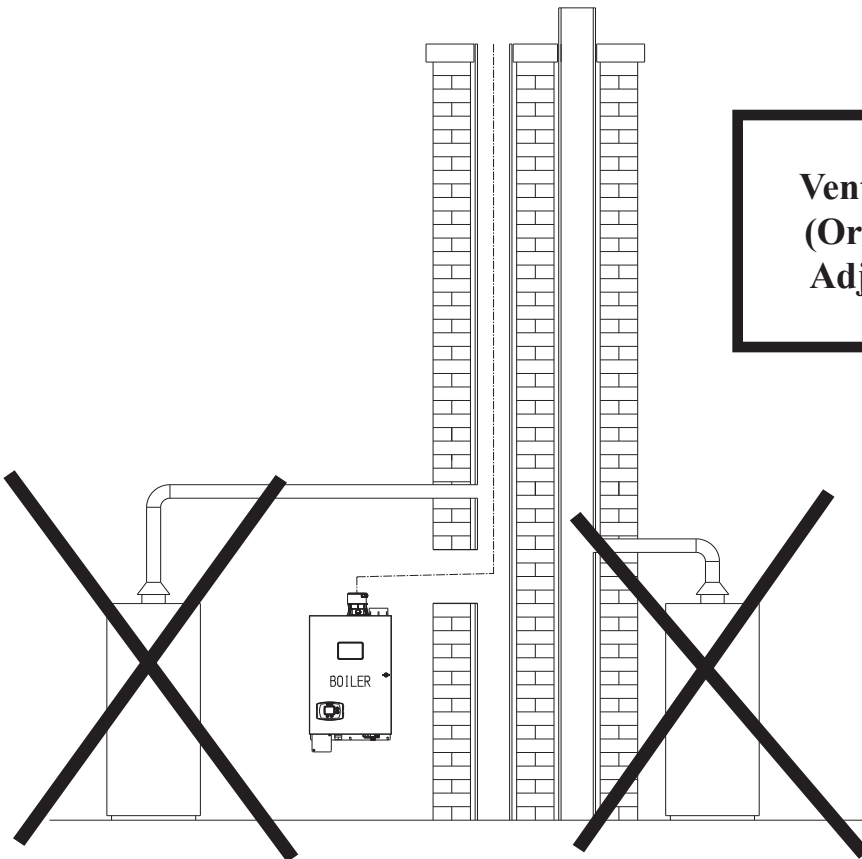

FIGURE 7.25: MASONRY CHIMNEY CHASE REQUIREMENTS

E. Assembly of CPVC/PVC Vent Systems



WARNING

- **Asphyxiation Hazard.** Failure to follow these instructions could cause products of combustion to enter the building, resulting in severe property damage, personal injury, or death.
- Use all CPVC vent components (supplied with the boiler) for near-boiler vent piping before transitioning to Schedule 40 PVC pipe (ASTM 2665) components for remainder of vent system.
- Use CPVC vent components within any interior space where air cannot circulate freely, including through vertical or horizontal chase ways, inside a stud wall, in closets and through wall penetrations.
- The use of cellular core PVC (ASTM F891), cellular core CPVC or Radel (polyphenolsulfone) is prohibited.
- All condensate that forms in the vent must be able to drain back to the boiler.
- Never leave the boiler in operation without the gas sample cap in place (Figure 7.27)

1. Assemble the vent system, starting at the boiler:

- a. A CPVC elbow and a 30" straight section of CPVC (not supplied) must be used before transitioning to PVC. If necessary the 30" straight section of CPVC may be cut in any location and the CPVC elbow inserted between the two resulting segments.
- b. When cutting CPVC or PVC pipe, use a miter saw or a saw designed to cut PVC pipe. Use a miter box or other method to cut pipe squarely. De-burr both the inside and outside of the cut end.
- c. Dry fit all vent components before assembly.
- d. Lubricate the upper gasket in the vent adaptor with water and insert the first piece of CPVC into the vent adaptor until it bottoms out. Tighten the gear clamp on the adaptor.
- e. Assemble the CPVC elbow and the remainder of the 30" CPVC piping before transitioning to PVC. The first piece of PVC will either be connected to the CPVC elbow or the end of a section of CPVC vent pipe. In the latter case, a PVC coupling may be used to connect the first piece of PVC to the last piece of CPVC.
- f. Clean all CPVC and PVC components with the appropriate primer before cementing. Cement the vent system together, starting at the boiler and following the instructions provided on the cans of cement and primer. Use a field supplied cement and primer that is listed for use with the materials being joined (CPVC and/or PVC). The following, or its equivalent, may be used to join CPVC to PVC:
 - IPS Corporation #P-70 Primer
 - IPS Corporation #790 Multi-Purpose Solvent Cement

Always use primer on both the pipe and fitting before applying the cement. Assemble the pipe in accordance with the instructions on the cans of primer and cement.

- g. Assemble the rest of the vent system, being sure to pitch horizontal sections back towards the boiler 1/4"/ft. Support the vent at intervals not exceeding 4ft.
 - h. Maintain the clearances from the vent pipe outlined in Part VII-A of this manual. If exiting the exterior wall using PVC pipe, use half of an appropriately sized wall thimble (or a sheet metal plate) on the exterior of the building, to provide a weather tight seal while maintaining the proper clearance in the wall penetration. Seal the joint between the pipe and the wall plate using RTV applied on the exterior side of the wall. This sealant must not restrain the expansion of the vent pipe.
2. Installation of Air Intake System - Start assembly of the PVC air intake system at the boiler. Assembly of the air intake system is done in the same manner as the vent system except as follows:
- a. Drill a 7/32" clearance hole into the front side of the air intake adapter. Insert the first piece of PVC air intake pipe into the air intake connection and drill a 1/8" tap hole into the PVC which lines up with the 7/32" clearance hole and secure them together with a #10 x 1" sheet metal screw. Seal the joint between the intake pipe and the adaptor with RTV.
 - b. All intake piping may be PVC.
 - c. There is a 0" minimum clearance between the air intake piping and all types of construction.
 - d. To the extent possible, pitch horizontal air intake piping towards the outdoors.
3. Installation of Horizontal Fitting Terminals (Terminal Option A):
- a. See Figure 7.28 for proper orientation of twin pipe horizontal terminals. Outer edge of both terminals must be within 10" from wall surface. (Figure 7.6)

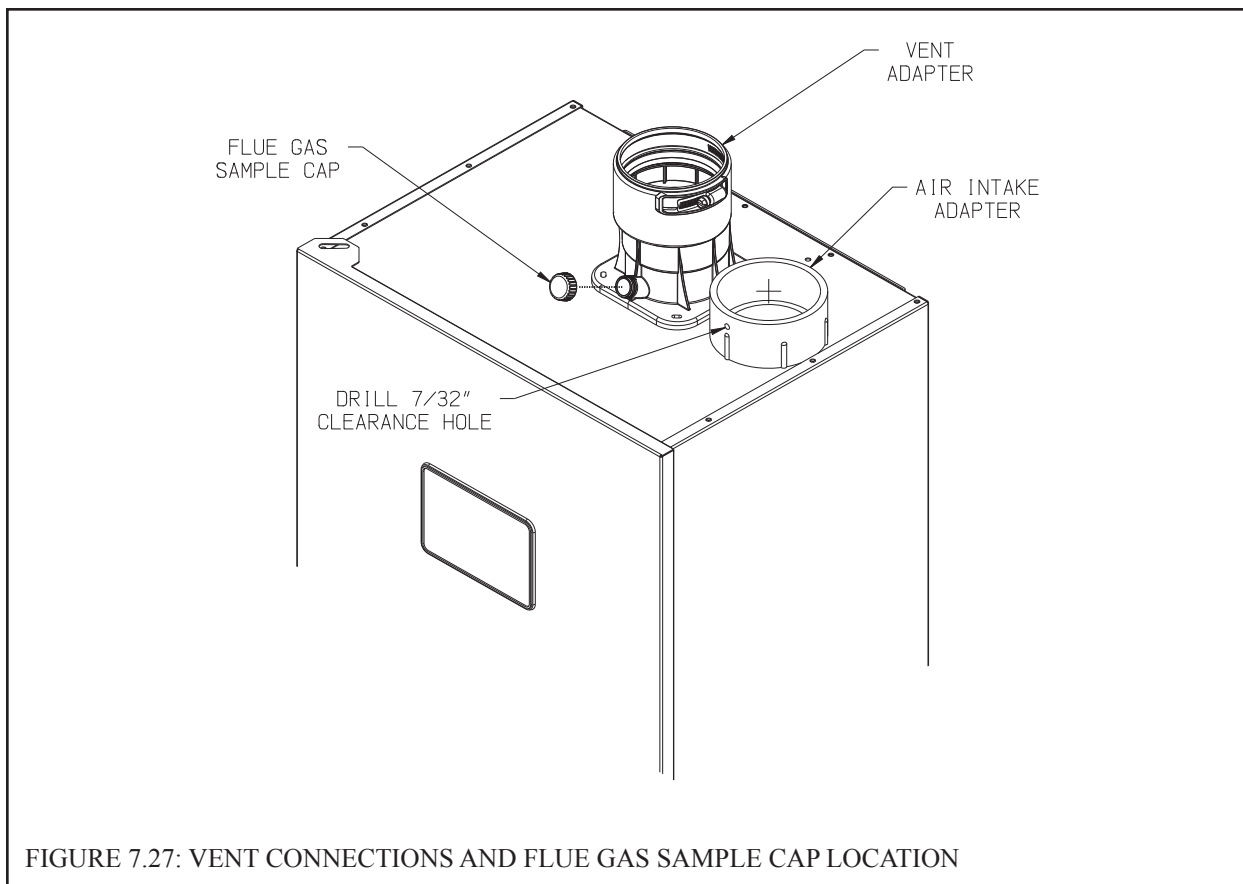

FIGURE 7.27: VENT CONNECTIONS AND FLUE GAS SAMPLE CAP LOCATION

- b. If desired, the terminals can be attached to the end of the vent and/or intake pipes with field supplied stainless steel screws so that they can be later removed for cleaning and inspection. If this is done, drill a clearance hole in the coupling or elbow and a tap hole in the end of the vent/intake pipes to accept these screws.
 - c. If these terminals are installed on snorkels, assemble the snorkels as shown in Figure 7.12. Brace the vertical run of piping on the building exterior as required.
4. Installation of Vertical Fitting Terminals (Terminal Option H):
- a. See Figure 7.29 for the proper orientation of twin pipe vertical terminals.
 - b. The coupling is used to secure the rodent screen to the end of the vent pipe.
 - c. A 180° bend (or two 90° elbows) are installed on the top of the air intake pipe. If two 90° elbows are used, the rodent screen provided can be installed between them (Figure 7.29). If a 180° bend is used, install the rodent screen in the open side of the bend, using a ring made of PVC pipe. If desired, the termination fittings can be attached to the end of the vent and/or intake pipes with field supplied stainless steel screws so that they can be later removed for cleaning and inspection. If this is done, drill a clearance hole in these fittings and a tap hole in the end of the vent/intake pipes to accept these screws.
 - d. Use roof flashings and storm collars to prevent moisture from entering the building. Seal the roof flashing to the roof using generally accepted practice for the type of roof on the installation. Apply RTV to seal the storm collars to the vent and intake pipes.
5. Installation of IPEX low profile vent terminal (Terminal Option B) - See Figure 7.30:
- a. Cut two holes in wall to accommodate the size PVC pipe being used. The distance between hole centers is 5.6”.
 - b. Slide both vent and intake air pipes through the holes. and cement them to the base of the vent termination kit using a primer and cement listed for use with PVC.
 - c. Fasten the vent base to the wall using the supplied screws and anchors. The anchors require the drilling of a 3/16” hole x 1-3/16” deep. Locate the holes using the vent base as a template.
 - d. Screw the vent cap to the vent base using the supplied screws.
 - e. Once the vent termination and pipes are secure seal the wall penetrations from the interior using a weather resistant RTV sealant.
6. Installation of Diversitech Low Profile Terminal (Terminal Option C) – See Figure 7.31:
- a. Use vent plate as a guide to locate the openings for the vent and air intake pipes, as well as to locate the holes for the mounting screws.

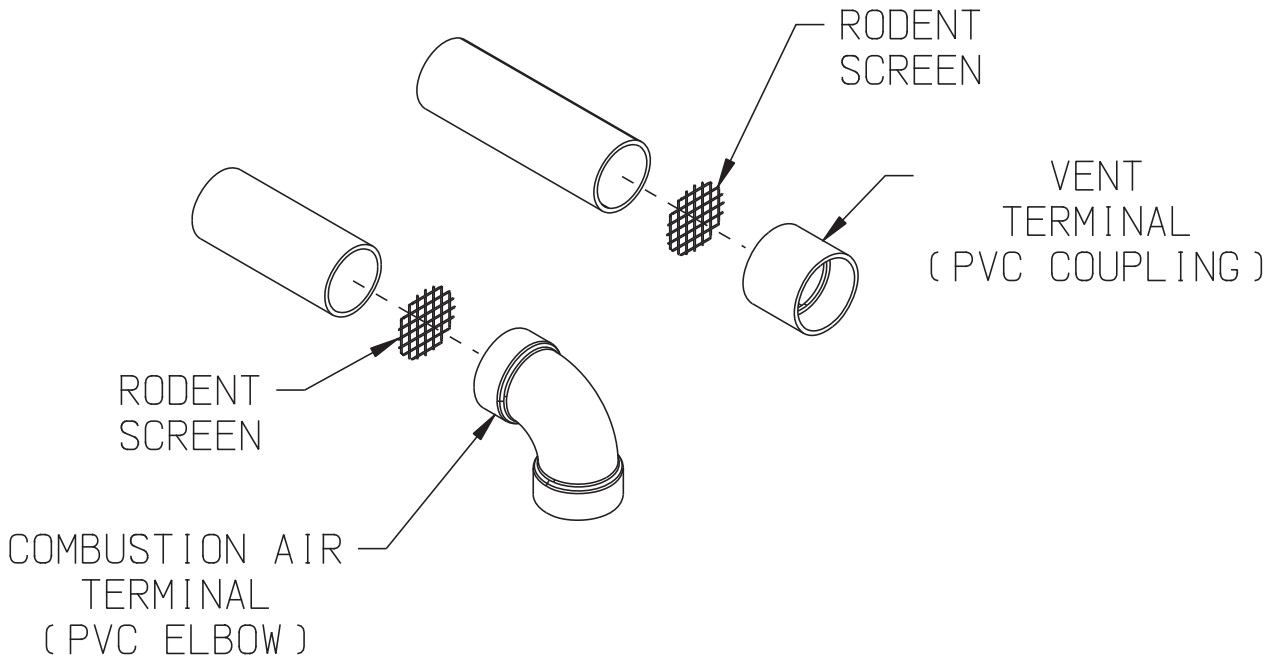

FIGURE 7.28: INSTALLATION OF STANDARD HORIZONTAL TERMINALS

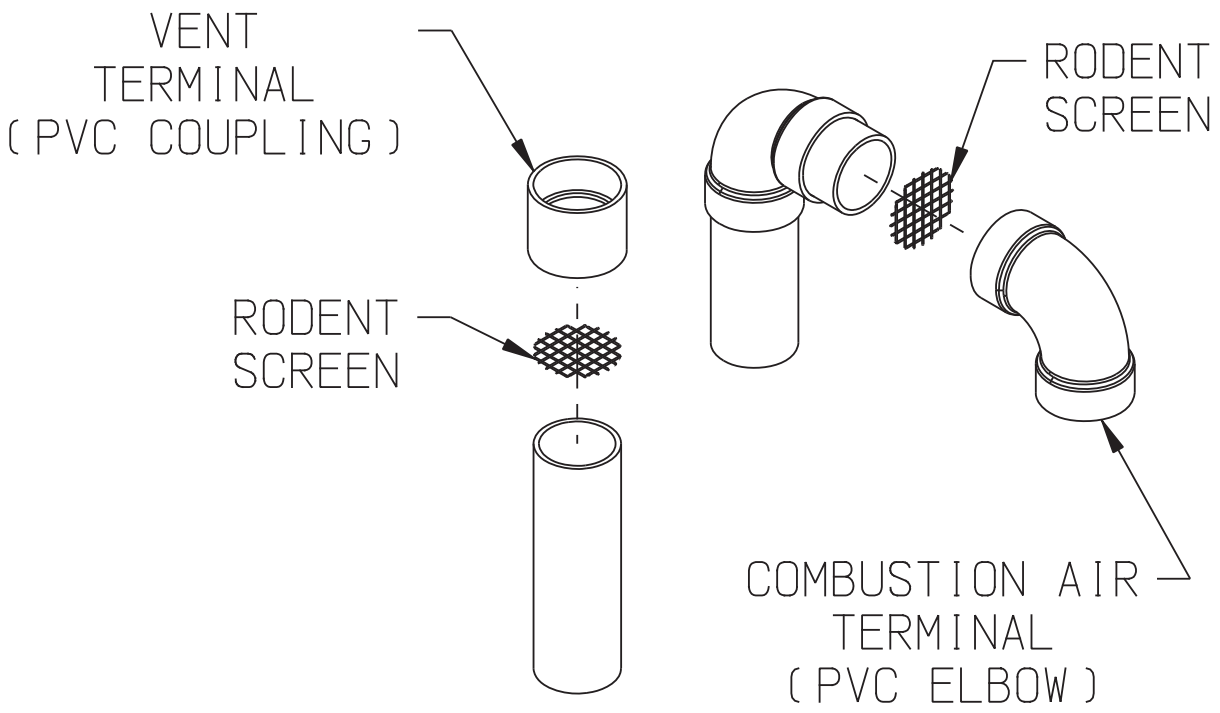

FIGURE 7.29: INSTALLATION OF STANDARD VERTICAL TERMINALS

- b. Drill two 3-1/8 holes through the wall for the vent and intake pipes.
 - c. Drill four 3/16 holes for the mounting screws.
 - d. Install the vent and intake pipe sections passing through the wall. Cut the pipes so that they protrude the following distances from the surface on which the vent plate will be mounted:
 - Vent: Between 1-3/4 and 2-1/4"
 - Intake: Between 1/4 and 1"
 - e. Seal pipe penetrations in wall with RTV (silicone sealant).
 - f. Mount the vent plate using the #8 x 2" screws and anchors provided with this kit.
 - g. Seal the vent plate to the wall with RTV.
 - h. Apply a bead of RTV around the OD of the vent pipe near its end.
 - i. Slide the vent cap over the vent pipe and secure to the wall plate with the #8 x 2" screws provided.
7. Installation of IPEX FGV or Diversitech CVENT Concentric Vent Terminal (Terminal Options D,E,I & J) - This terminal may be used for either horizontal or vertical venting. See Figure 7.33 for horizontal installation or Figure 7.34 for vertical installation. When PVC is used for venting, a 30" CPVC straight section and CPVC elbow must be used prior to connection of the vent system to this terminal. If the vent system is too short to permit this, use the IPEX FGV CPVC terminal:
- a. For horizontal installations at the planned location cut a round hole in the exterior wall 1/2" larger than the "C" dimension indicated on Figure 7.32 for the size terminal being used. (See Part VII-B of this manual for permitted terminal locations).
 - b. For vertical installations, cut a hole in the roof large enough to clear the concentric terminal at the location of the terminal (see Part VII-C of this manual for permitted terminal locations).
 - c. If desired, the terminal can be shortened. See Figure 7.32 for specific information on making the terminal kit shorter based on the kit size being used. Cut the pipe squarely and de-burr both the OD and ID of the cut edges.
 - d. Cement the inner pipe section of PVC pipe supplied with this kit to the Wye fitting using a primer and cement listed for use with PVC.



WARNING

- **Asphyxiation Hazard. CPVC/PVC vent piping and fittings rely on glued joints for proper sealing. Follow all manufacturer instructions and warnings when preparing pipe ends for joining and using the primer and the cement.**
- **When PVC is used with the concentric vent kit, the 30" CPVC straight section and elbow must be used prior to connection of the vent system to this terminal. If the vent system is too short to permit this, use an IPEX FGV CPVC terminal.**
- **Do not operate boiler without the rain cap in place.**
- **Method of securing and sealing terminals to the outside wall must not restrain the expansion of vent pipe.**

- e. Cement the outer pipe to the Wye, being careful, to keep the inner and outer pipes concentric.
- f. Slip the partially assembled terminal through the wall or ceiling from the inside and for horizontal installations orient so that the side outlet on the Wye is on or above the horizontal plane.
- g. For horizontal installations, seal the gap between the OD of the "outer pipe" and the exterior side of the wall with RTV sealant.
- h. Cement the rain cap onto the inner pipe. If desired, the rain cap can be attached to the inner pipe with the supplied stainless steel screw and nut so that it can be later removed for cleaning and inspection. If this is done, drill a 3/16" clearance hole in the rain cap and inner pipe in the location shown on Figure 7.32 for the size terminal kit being used and affix screw and nut. Do not overtighten. A field supplied rodent screen may also be installed on the end of the rain cap.
- i. For vertical installations, use a roof flashing and storm collar to prevent moisture from entering the building. Seal the roof flashing to the roof using generally accepted practice for the type of roof on the installation. Install the storm collar after verifying that the bottom of the rain cap will be at least 12" above the normal snow line. Apply RTV to seal the storm collars to the terminal.

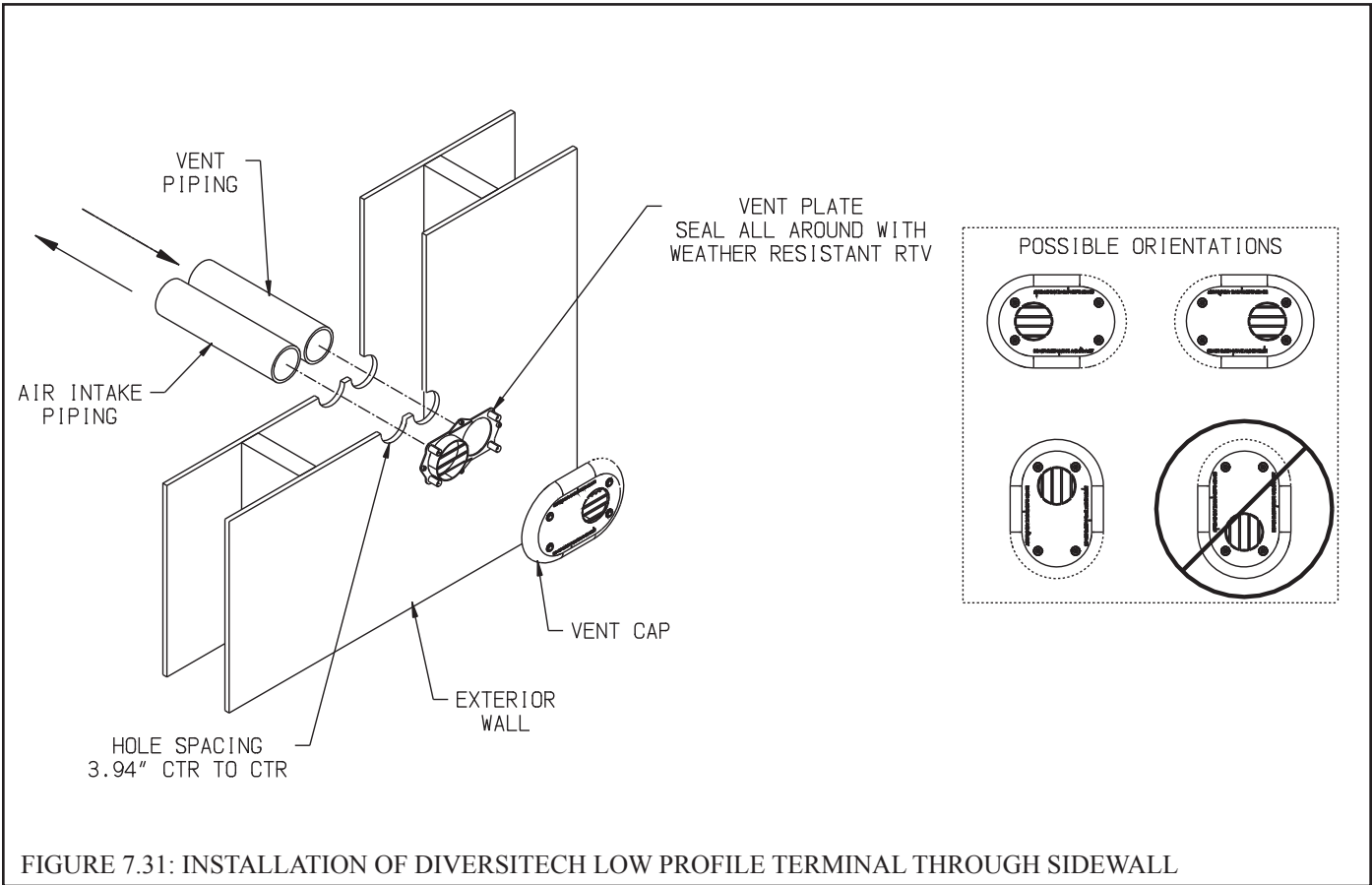
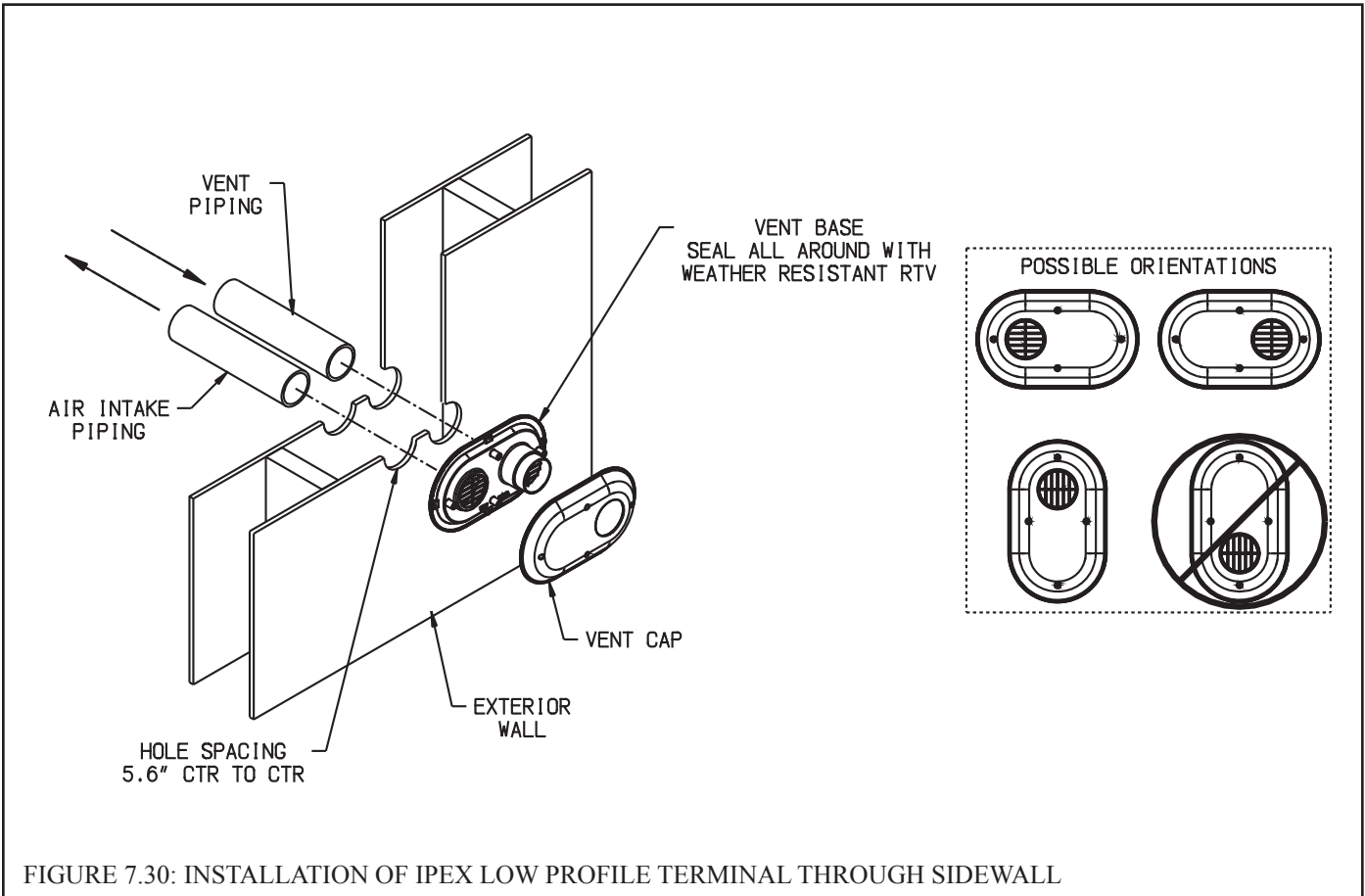

*OVERALL LENGTH OF INNER PIPE TO BE 'A' INCHES LONGER THAN OVERALL LENGTH OF OUTER PIPE.

KIT SIZE	*' A'	' B'	' C'	MANUFACTURER
2"	7-3/8"	1-3/4"	3-1/2"	IPEX
2"	12-3/16"	3/4"	3-1/2"	DIVERSITECH
3"	8-3/4"	2-1/4"	4-1/2"	IPEX
3"	13-3/16"	1"	4-1/2"	DIVERSITECH

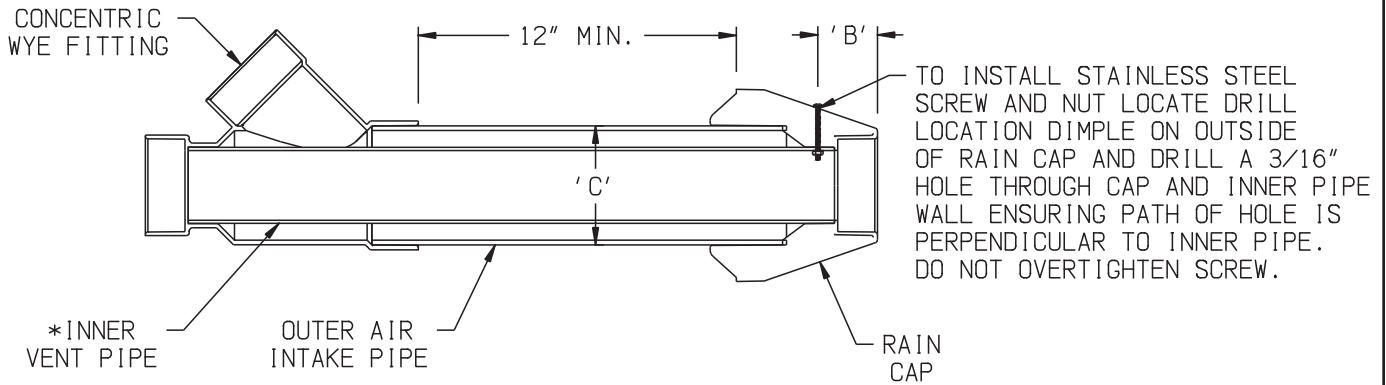

- NOTES: 1. ALL CUTS MUST BE SQUARE AND DEBURRED.
 2. LENGTHENING OF TERMINAL IS NOT PERMITTED.

FIGURE 7.32: CUTTING IPEX AND DIVERSITECH CONCENTRIC VENT TERMINALS

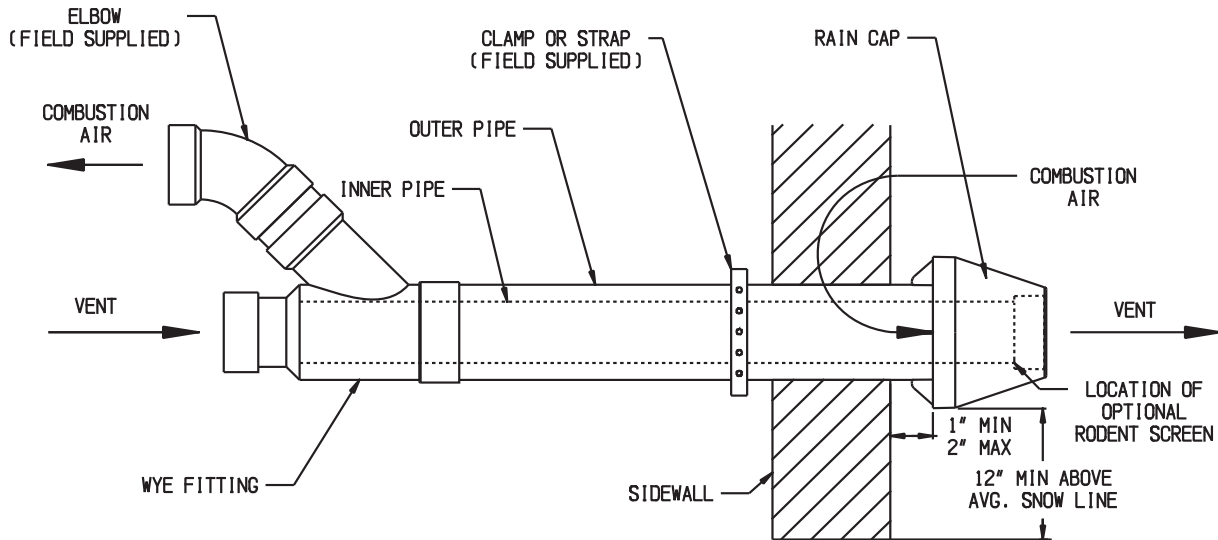

FIGURE 7.33: INSTALLATION OF IPEX AND DIVERSITECH CONCENTRIC TERMINAL THROUGH SIDEWALL

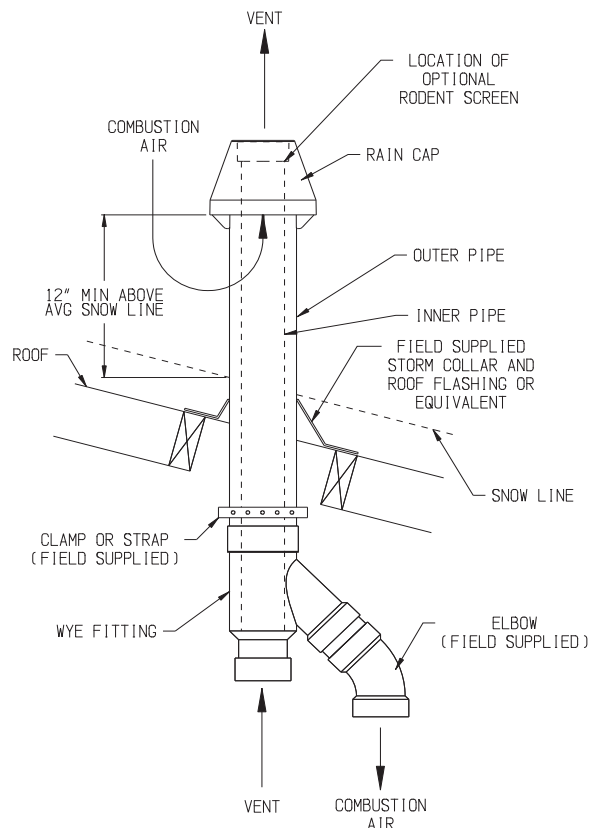

FIGURE 7.34: INSTALLATION OF IPEX AND DIVERSITECH CONCENTRIC TERMINAL THROUGH ROOF

F. Assembly of DuraVent PolyPro Vent Systems

1. This boiler has been approved for use with the DuraVent PolyPro single wall polypropylene vent system to be provided by the installer.



WARNING

- **Asphyxiation Hazard. Follow these instructions and the installation instructions included by the original polypropylene venting component manufacturer, M&G/DuraVent. Failure to do so could cause products of combustion to enter the building, resulting in severe property damage, personal injury or death. Where a conflict arises between M&G/DuraVent instructions and these instructions, the more restrictive instructions shall govern.**
- **Do not mix vent components or joining methods for listed manufacturers.**
- **Examine all components for possible shipping damage prior to installation.**
- **All condensate that forms in the vent must be able to drain back to the boiler.**

2. Assemble the vent system, starting at the boiler:
 - a. Vent adaptors accept PolyPro vent pipe as is. The 3" adaptor used on the 120-180 has two different diameter vent gaskets. The lower gasket accepts 3" PolyPro. Lubricate the gasket on the vent adaptor (lubricate the lower gasket on the 3" adaptor) with soapy water and insert the first piece of PolyPro into the adaptor until it bottoms out. Tighten the gear clamp on the adaptor.
 - b. If an 80 or 100 is to be used with 3" venting, insert a short (less than 30") length of 2" straight pipe and then install a PolyPro #2PPS-X3L 2 x 3" increaser. This increaser must be installed in the first vertical run of pipe at the boiler to prevent condensate from becoming trapped at the reduction.
 - c. For each joint, verify that the gasket is evenly seated in the bell (female) end of the pipe. Lubricate this gasket with water. Slide a locking band over the male end of the pipe to be joined as shown in Figure 7.35. Push the male end of the next section of pipe into the bell until it bottoms out, then back out 1/4-5/8" to provide room for thermal expansion. Push barb on locking band over the bell end of the first section of pipe as shown in Figure 7.35.
 - d. Assemble the rest of the vent system per the manufacturer's installation instructions, being sure to pitch horizontal sections back towards the boiler 5/8" per ft.
 - e. Support each horizontal pipe section with a minimum of one wall strap each and at intervals not exceeding 4ft.

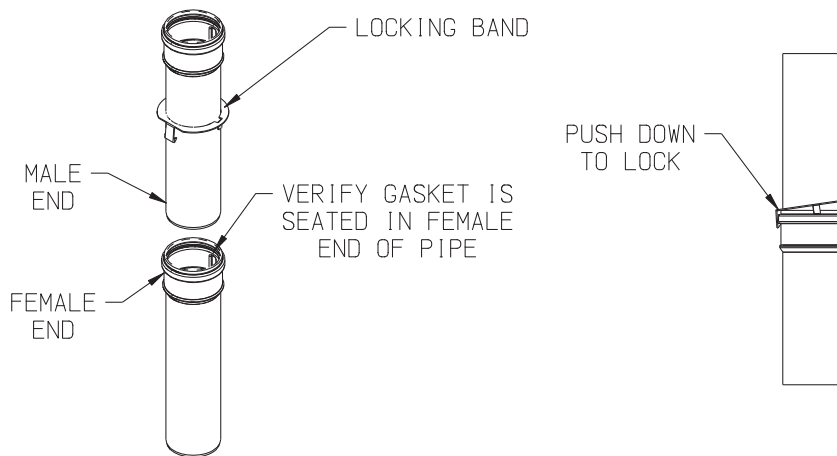

FIGURE 7.35: POLYPRO LOCKING BAND INSTALLATION

3. Installation of Air Intake System - Start assembly of the PVC air intake system at the boiler. Assembly of the air intake system is done in the same manner as a CPVC/PVC vent system except as follows:
 - a. Drill a 7/32" clearance hole into the front side of the air intake adapter. Insert the first piece of PVC air intake pipe into the air intake connection and drill a 1/8" tap hole into the PVC which lines up with the 7/32" clearance hole and secure them together with a #10 x 1" sheet metal screw. Seal the joint between the intake pipe and the adaptor with RTV.
 - b. All intake piping may be PVC.
 - c. There is a 0" minimum clearance between the air intake piping and all types of construction.
 - d. To the extent possible, pitch horizontal air intake piping towards the outside.

WARNING

Asphyxiation Hazard. Vent systems made by M&G/DuraVent rely on gaskets for proper sealing. When this vent system is used, take the following precautions:

- Make sure that gasket is in position and undamaged in the female end of the pipe.
- Make sure that both the male and female pipes are free of damage prior to assembly.
- Only cut vent pipe as permitted by the vent manufacturer in accordance with their instructions. When pipe is cut, the cut end must be square and carefully de-burred prior to assembly.
- Use locking bands at all vent pipe joints.
- Do not use anything other than soapy water to lubricate gaskets.

NOTICE

The venting system must be free to expand and contract and supported in accordance with the installation instructions included by the original polypropylene venting component manufacturer, M&G/DuraVent. Polypropylene pipe sections must be disengaged 1/4 to 5/8 in. (6mm to 16mm) per joint to allow for thermal expansion.

4. Installation of Horizontal Fitting Terminals (Terminal Option A):
 - a. See Figure 7.36 for proper orientation of twin pipe horizontal terminals. Outer edge of exhaust coupling must be 10" or less from the wall surface. (Figure 7.9)
 - b. Remove the gasket from the end of the integral exhaust coupling and insert DuraVent Bird Guard #2PPS-BG or #3PPS-BG in it's place.
 - c. Add PVC intake per instructions from Part VII-F.

5. Installation of Vertical Fitting Terminals (Terminal Option H):

- a. See Figure 7.37 for the proper orientation of twin pipe vertical terminals.
- b. Remove the gasket from the end of the integral exhaust coupling and insert the installer supplied rodent screen in its place.
- c. A 180° bend (or two 90° elbows) are installed on the top of the air intake pipe. If two 90° elbows are used, the rodent screen provided can be installed between them (Figure 7.37). If a 180° bend is used, install the rodent screen in the open side of the bend, using a ring made of PVC pipe. If desired, the termination fittings can be attached to the end of the intake pipes with field supplied stainless steel screws so that they can be later removed for cleaning and inspection. If this is done, drill a clearance hole in these fittings and a tap hole in the end of the intake pipes to accept these screws.
- d. Use roof flashings and storm collars to prevent moisture from entering the building. Seal the roof flashing to the roof using generally accepted practice for the type of roof on the installation. Apply RTV to seal the storm collars to the vent and intake pipes.

6. Installation of DuraVent PolyPro Horizontal Concentric Vent Terminal (Terminal Option D) -

Install PolyPro Horizontal Concentric Termination Kit #2PPS-HK or #3PPS-HK (Figure 7.39) as follows:

- a. At the planned location cut a 4-1/8" round hole for the 2" terminal or a 5-1/8" round hole for the 3" terminal in the exterior wall. (See Part VII-A of this manual for permitted terminal locations).
- b. If desired, the terminal can be shortened. Mark the desired location of the cut on the outer pipe no closer than 2" from the edge of the tab on the interior wall plate. Prior to cutting outer pipe measure dimension 'A' of the inner pipe as shown in Figure 7.38 and maintain this dimension after cutting the outer pipe. All cuts must be square and de-burred.
- c. Attach the exterior wall plate and seal all around with weather resistant RTV.
- d. Slide the cap through the exterior wall plate and hole from the outside of the building and orient the termination so the air intake slots face down. The cap must be installed level or sloped 1/8" per foot away from the appliance.
- e. Seal the termination to the exterior wall plate with weather resistant RTV.
- f. Slide the interior wall plate over the termination and attach to the wall from inside the room.
- g. Attach the interior wall plate to the termination with the provided hardware.
- h. Install gaskets into co-linear adapter.
- i. Attach co-linear adapter to horizontal termination and orient so that the side outlet on the adapter is on or above the horizontal plane.

7. Vertical Installations using PolyPro Vertical Concentric Termination Kit #2PPS-VK or #3PPS-VK (Figure 7.40):

- a. Cut a hole in the roof large enough to clear the concentric terminal at the location of the terminal (see Part VII-A of this manual for permitted terminal locations).
- b. Use a roof flashing and storm collar to prevent moisture from entering the building. See Figure 7.40 for the model number of the flashing to be used depending on the type of roof. Seal the roof flashing to the roof using generally accepted practice for the type of roof on the installation.
- c. Slide the vertical termination into the flashing from above until seated on the flashing.
- d. Plumb the termination and mount the support bracket to the structure.
- e. Install gaskets into co-linear adapter.
- f. Attach co-linear adapter to vertical termination.

8. Installations using PolyPro-flex (Vent Options 18,19,33,34):



WARNING

Asphyxiation Hazard. When using Polypro flex, observe the following precautions:

- **Polypro flex may be damaged by handling at low temperatures. Do not bend, uncoil, or attempt to install if it has been stored at a temperature below 42F without allowing it to warm to a higher temperature first.**
- **Do not bend PolyPro flex more than 45 degrees.**
- **Instructions below reference the DuraVent PolyPro Flex instruction manual. Not all vent configurations shown in the DuraVent manual are approved for use with this boiler.**

Refer to DuraVent Polypro flex Instructions for assembly of all flex components including the chimney cap and the adaptor to rigid Polypro at the base of the masonry or B vent chimney. In addition, observe the following requirements:

- a. Refer to the appropriate Vent option in Tables 7.13b or 7.21 for a list of the principle flex components required. Rigid vent pipe by the same manufacturer will also be required for the run from the boiler to the base of chimney.

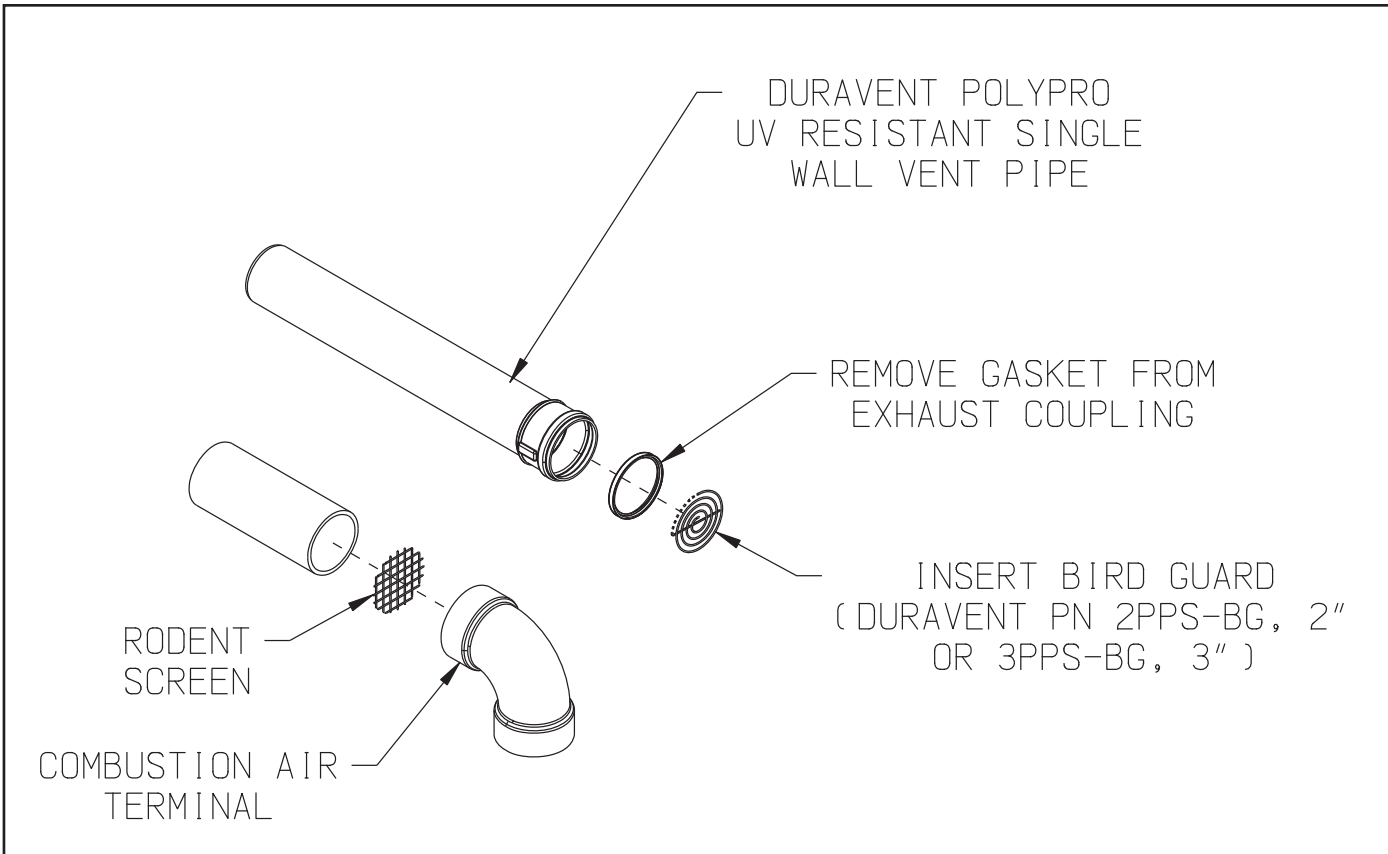

FIGURE 7.36: INSTALLATION OF DURAVENT POLYPRO UV RESISTANT SINGLE WALL HORIZONTAL TERMINAL

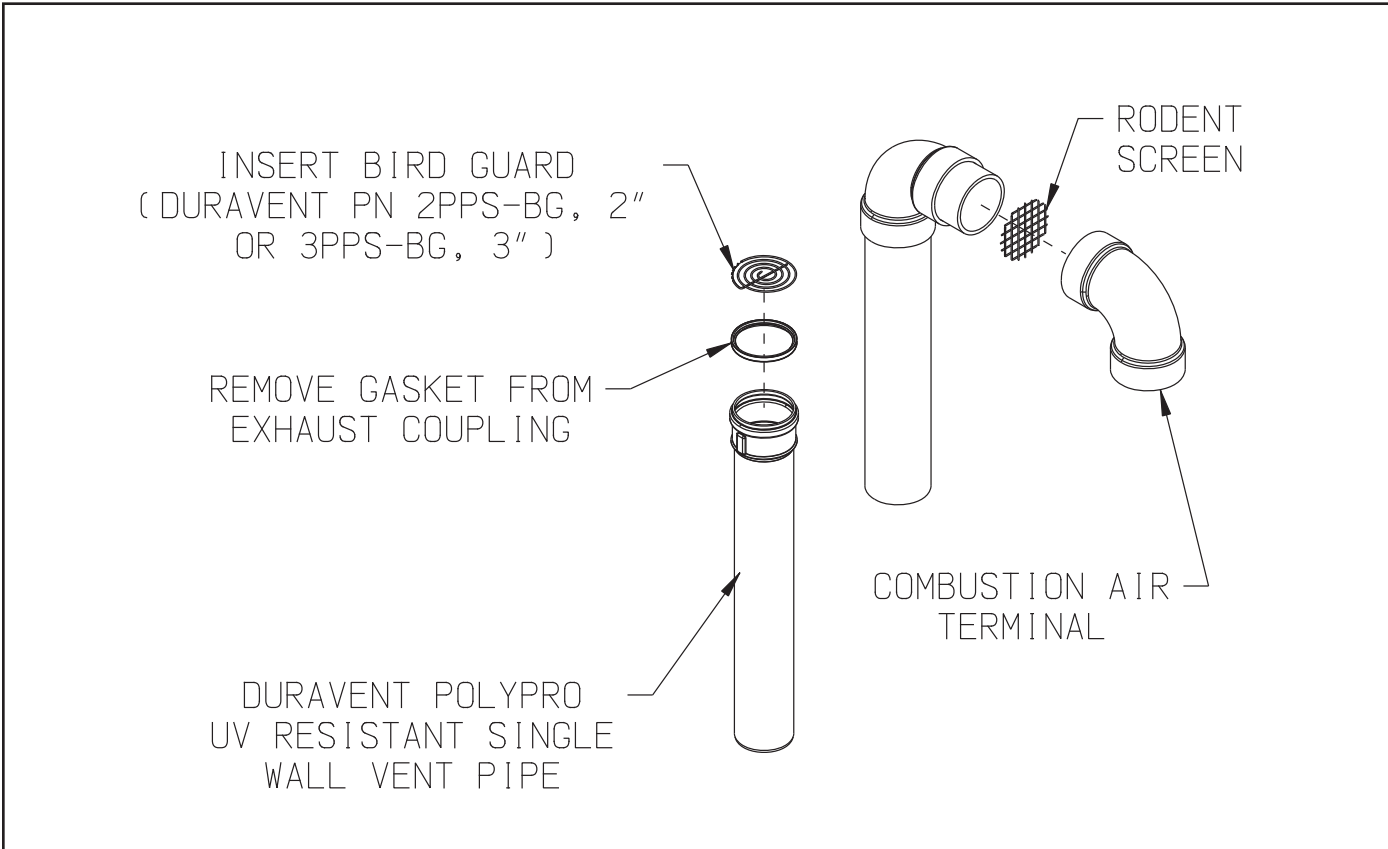

FIGURE 7.37: INSTALLATION OF DURAVENT POLYPRO UV RESISTANT SINGLE WALL VERTICAL TERMINAL

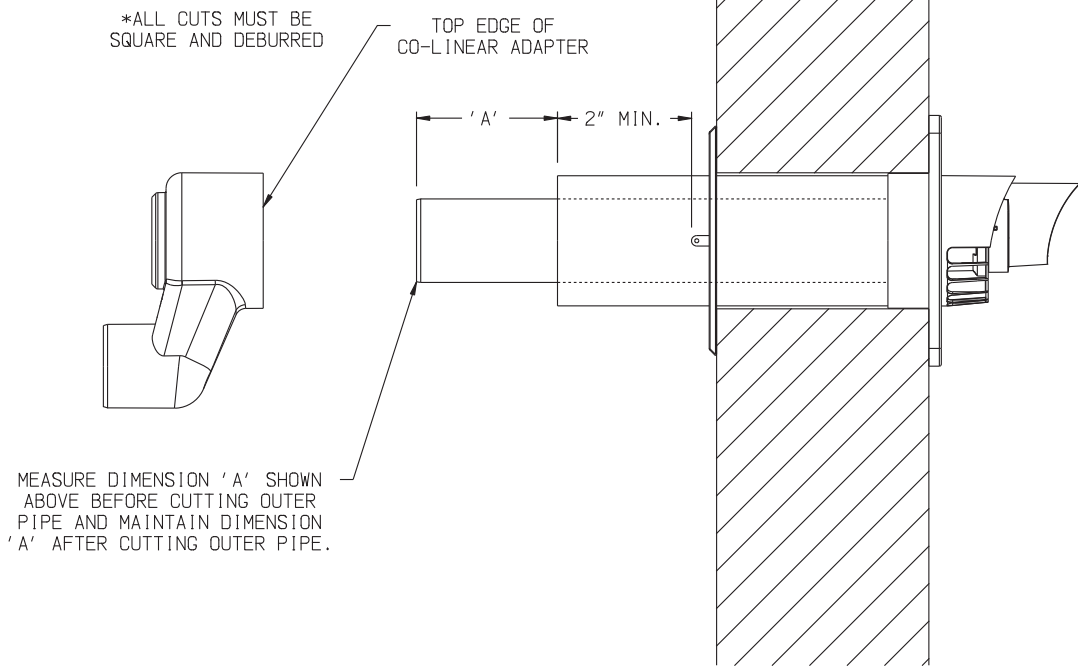

FIGURE 7.38: CUTTING DURAVENT POLYPRO HORIZONTAL CONCENTRIC VENT TERMINAL

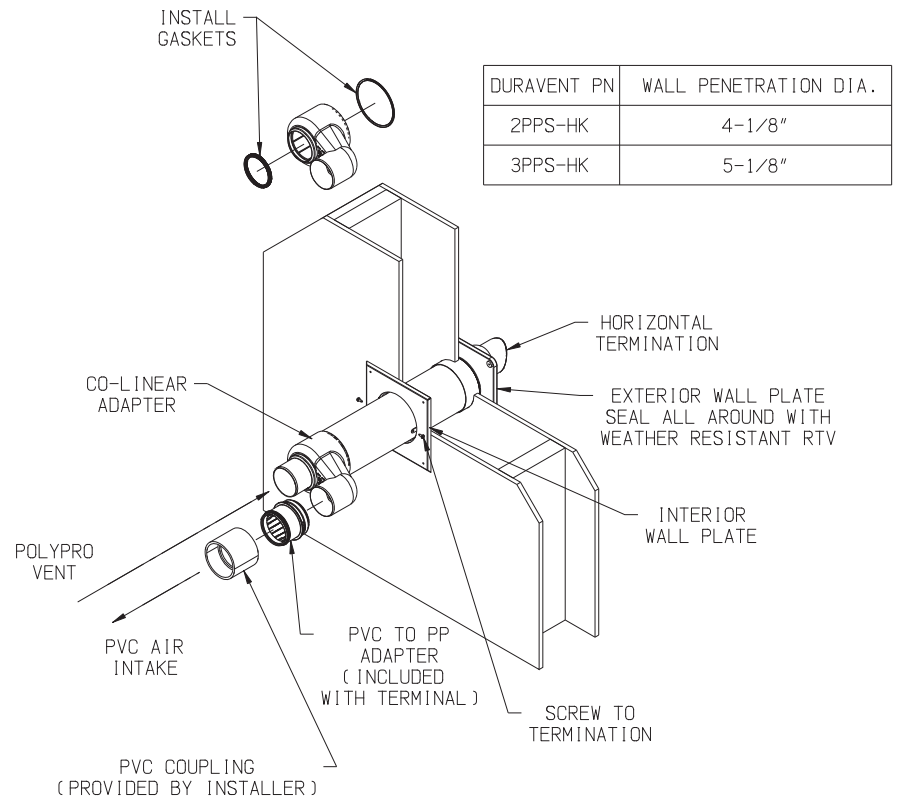

FIGURE 7.39: INSTALLATION OF DURAVENT POLYPRO CONCENTRIC VENT TERMINAL THROUGH SIDEWALL

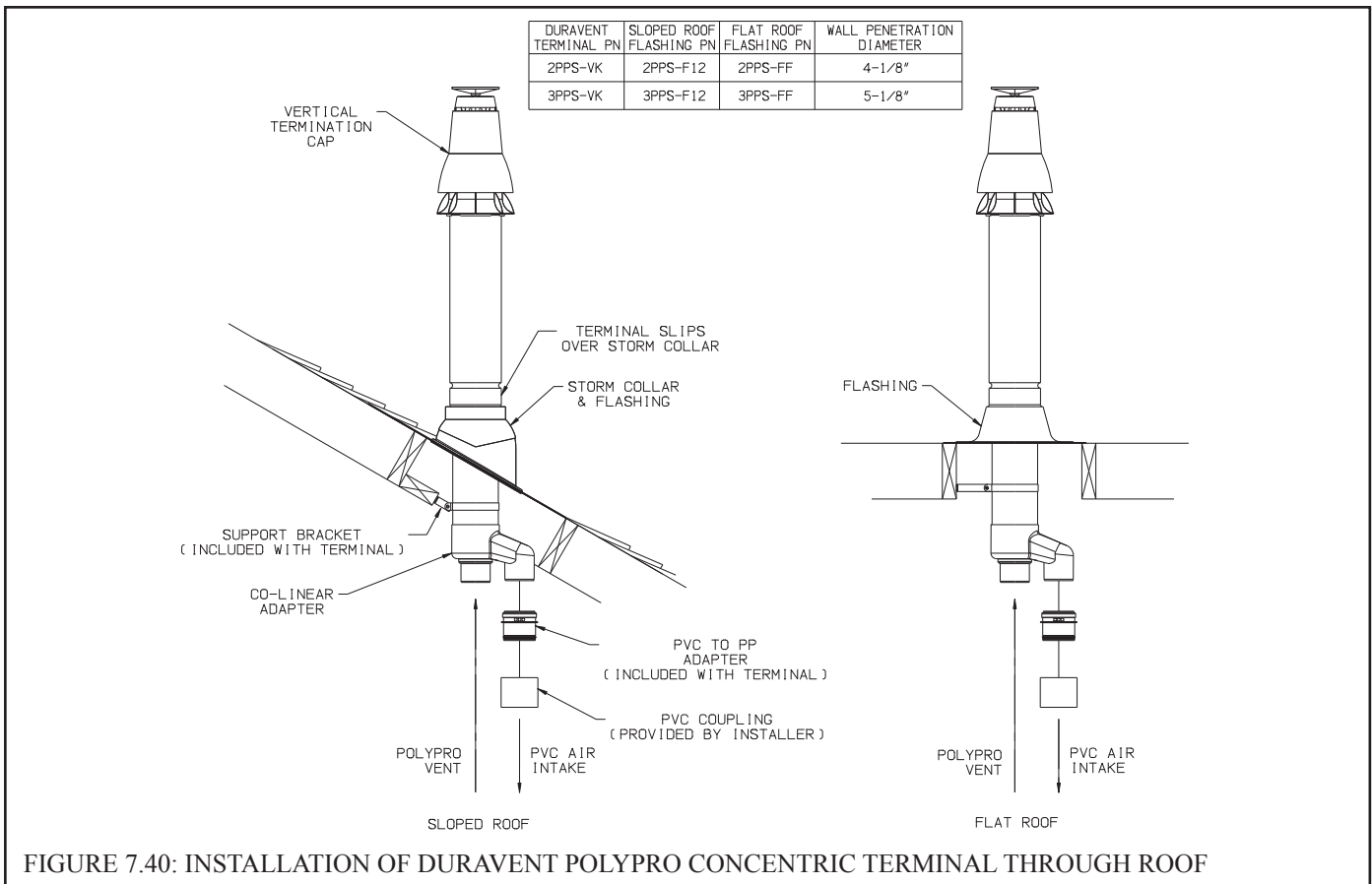

FIGURE 7.40: INSTALLATION OF DURAVENT POLYPRO CONCENTRIC TERMINAL THROUGH ROOF

- b. Masonry chimneys cannot be used for an air chase
- c. B vent chimneys can only be used for an air chase (Vent options 18, 19) if the B vent has the minimum size shown in Table 7.13b and is fully accessible for sealing of all joints and seams.
- d. When Vent Option 18 or 19 is used, install a Tee on the base of the B-vent that is the same size as the B- Vent chimney. Install the PolyPro Lower B-Vent adaptor in the base of this Tee as described in the DuraVent PolyPro Flex instructions. Connection of the PVC air intake pipe to the side outlet of the tee is made using a cap and a PVC socket x male thread adaptor (2" or 3", depending on the Vent Option). Cut a clearance hole in the cap for the male threads. Secure the adaptor to the cap using a 2" or 3" electrical conduit lock nut. Seal all joints with RTV.

G. Assembly of Selkirk Polyflue Vent Systems

- 1. This boiler has been approved for use with the Selkirk Polyflue single wall polypropylene vent system to be provided by the installer.

WARNING

Asphyxiation Hazard. Follow these instructions and the installation instructions included by the original polypropylene venting component manufacturer, Selkirk. Failure to do so could cause products of combustion to enter the building, resulting in severe property damage, personal injury or death. Where a conflict arises between Selkirk instructions and these instructions, the more restrictive instructions shall govern.

- Do not mix vent components or joining methods for listed manufacturers.
- Examine all components for possible shipping damage prior to installation.
- All condensate that forms in the vent must be able to drain back to the boiler.

2. Assemble the vent system, starting at the boiler:

- a. Vent adaptors accept Polyflue vent pipe as is. The 3" adaptor used on the 120-180 has two different diameter vent gaskets. The lower gasket accepts 3" Polyflue. Lubricate the gasket on the vent adaptor (lubricate the lower gasket on the 3" adaptor) with soapy water and insert the first piece of Polyflue into the adaptor until it bottoms out. Tighten the gear clamp on the adaptor.
- b. If an 80 or 100 is to be used with 3" venting, insert a short (less than 30") length of 2" straight pipe and then install a Selkirk #2PF-2I3 2 x 3" increaser. This increaser must be installed in the first vertical run of pipe at the boiler to prevent condensate from becoming trapped at the reduction.
- c. For each joint, verify that the gasket is evenly seated in the bell (female) end of the pipe. Lubricate this gasket with mild soapy water. Slide a Pipe Locking Band over the male end of the pipe to be joined as shown in Figure 7.41. Push the male end of the next section of pipe into the bell until it bottoms out, then back out 1/8—1/4" to provide room for thermal expansion. Slide pipe locking band over the female end of the connections and tighten both hose clamps.
- d. Assemble the rest of the vent system per the manufacturer's installation instructions, being sure to pitch horizontal sections back towards the boiler 5/8" per ft.
- e. Support each pipe section as described in Polyflue manual at intervals not exceeding the following:

Pipe size	Horizontal	Vertical
2"	30in	16ft
3"	39in	16ft

3. Installation of Air Intake System - Start assembly of the PVC air intake system at the boiler. Assembly of the air intake system is done in the same manner as a CPVC/PVC vent system except as follows:

- a. Drill a 7/32" clearance hole into the front side of the air intake adapter. Insert the first piece of PVC air intake pipe into the air intake connection and drill a 1/8" tap hole into the PVC which lines up with the 7/32" clearance hole and secure them together with a #10 x 1" sheet metal screw. Seal the joint between the intake pipe and the adaptor with RTV.
- b. All intake piping may be PVC. There is a 0" minimum clearance between the air intake piping and all types of construction.
- c. To the extent possible, pitch horizontal air intake piping towards the outside.

4. Installation of Horizontal Fitting Terminals (Terminal Option A):

- a. See Figure 7.42 for proper orientation of twin pipe horizontal terminals. Outer edge of exhaust coupling must be 10" or less from the wall surface. (Figure 7.9)
- b. Remove the gasket from the end of the integral exhaust coupling and insert Selkirk #2PF-HVST or #3PFHVST in its place.
- c. Add PVC intake per instructions from Part VII-F.

5. Installation of Vertical Fitting Terminals (Terminal Option H):

- a. See Figure 7.43 for the proper orientation of twin pipe vertical terminals.
- b. Remove the gasket from the end of the integral exhaust coupling and insert Selkirk #2PF-HVST or #3PFHVST in its place.
- c. A 180° bend (or two 90° elbows) are installed on the top of the air intake pipe. If two 90° elbows are used, the rodent screen provided can be installed between them (Figure 7.43). If a 180° bend is used, install the rodent screen in the open side of the bend, using a ring made of PVC pipe. If desired, the termination fittings can be attached to the end of the intake pipes with field supplied stainless steel screws so that they can be later removed for cleaning and inspection. If this is done, drill a clearance hole in these fittings and a tap hole in the end of the intake pipes to accept these screws.
- d. Use roof flashings and storm collars to prevent moisture from entering the building. Seal the roof flashing to the roof using generally accepted practice for the type of roof on the installation. Apply RTV to seal the storm collars to the vent and intake pipes.



WARNING

Asphyxiation Hazard. Selkirk Polyflue vent systems rely on gaskets for proper sealing. When this vent system is used, take the following precautions:

- **Make sure that gasket is in position and undamaged in the female end of the pipe.**
- **Make sure that both the male and female pipes are free of damage prior to assembly.**
- **Only cut vent pipe as permitted by the vent manufacturer in accordance with their instructions. When pipe is cut, the cut end must be square and carefully de-burred prior to assembly.**
- **Use pipe locking bands at all vent pipe joints.**

NOTICE

The venting system must be free to expand and contract and supported in accordance with the installation instructions included by the original polypropylene venting component manufacturer, Selkirk. Polypropylene pipe sections must be disengaged 1/8 to 1/4 in. (3mm to 6mm) per joint to allow for thermal expansion.

6. Installations using flexible Polyflue (Vent Options 35,36):



WARNING

Asphyxiation Hazard. When using Polyflue flex, observe the following precautions:

- Polyflue flex may be damaged by handling at low temperatures. Do not bend, uncoil, or attempt to install if it has been stored at a temperature below 42F without allowing it to warm to a higher temperature first.
- Do not bend Polyflue flex more than 45 degrees.
- Instructions below reference the Selkirk Polyflue instruction manual. Not all vent configurations shown in the Selkirk vent manual are approved for use with this boiler.

Refer to Selkirk Polyflue Instructions for assembly of all flex components including the chimney cap and the adaptor to rigid Polyflue at the base of the masonry or B vent chimney. In addition, observe the following requirements:

- a. Refer to the appropriate Vent option in Table 7.21 for a list of the principle flex components required. Rigid vent pipe by the same manufacturer will also be required for the run from the boiler to the base of the chimney.
- b. Polyflue may not be used in air chase applications.

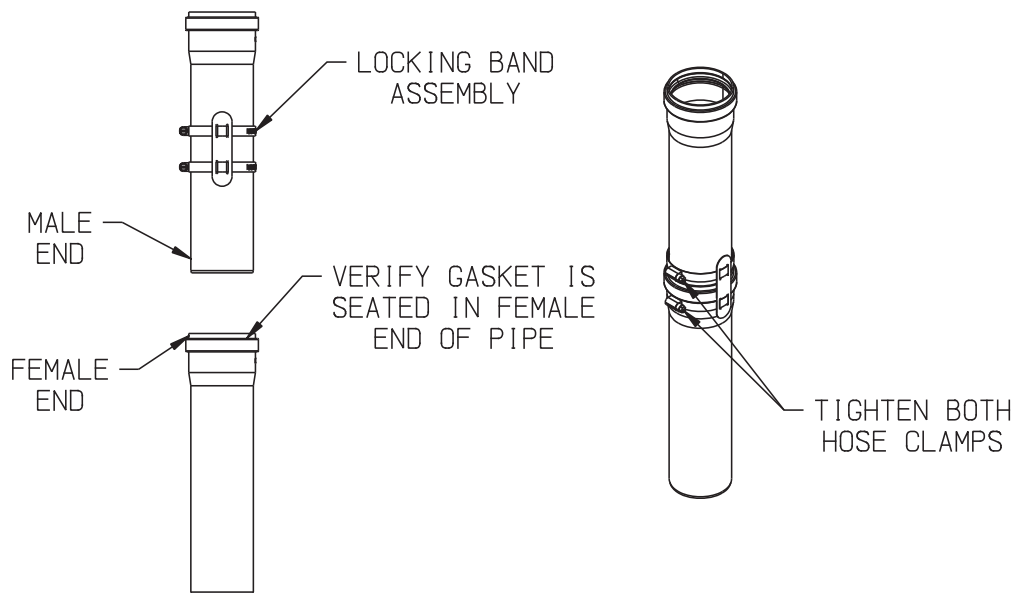

FIGURE 7.41: POLYFLUE PIPE LOCKING BAND INSTALLATION

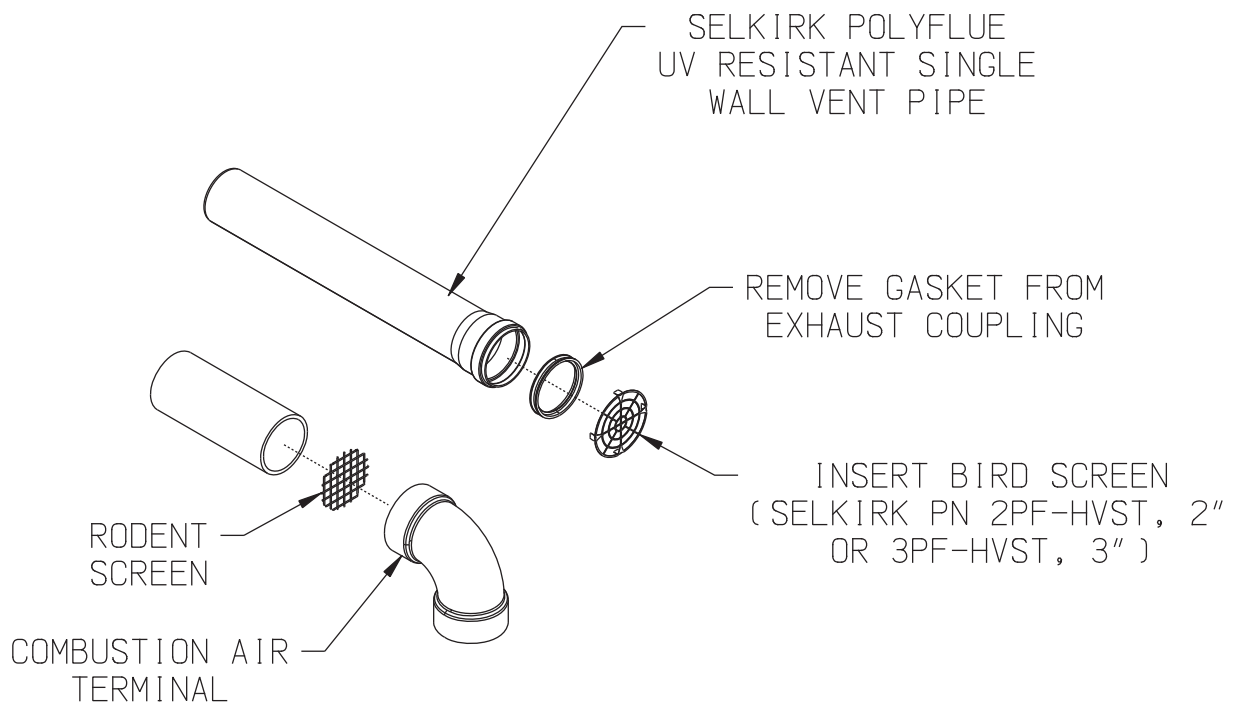

FIGURE 7.42: INSTALLATION OF SELKIRK POLYFLUE UV RESISTANT SINGLE WALL HORIZONTAL TERMINAL

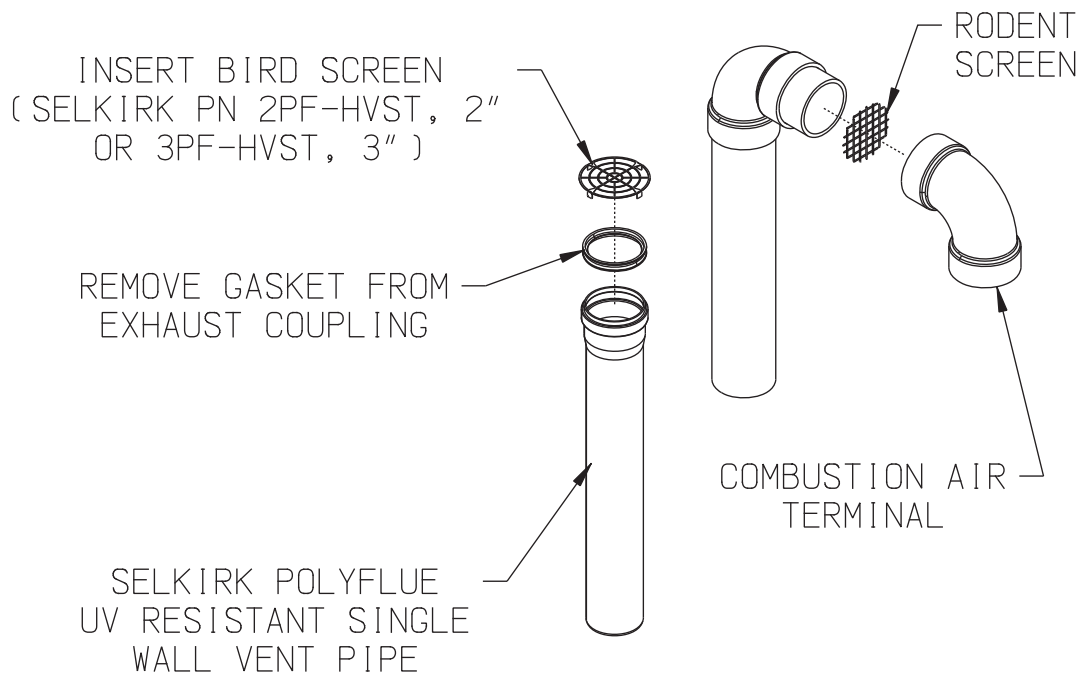

FIGURE 7.43: INSTALLATION OF SELKIRK POLYFLUE UV RESISTANT SINGLE WALL VERTICAL TERMINAL

H. Assembly of Centrotherm InnoFlue Vent Systems

1. This boiler has been approved for use with the Centrotherm InnoFlue single wall polypropylene vent system to be provided by the installer.



WARNING

- **Asphyxiation Hazard.** Follow these instructions and the installation instructions included by the original polypropylene venting component manufacturer, Centrotherm. Failure to do so could cause products of combustion to enter the building, resulting in severe property damage, personal injury or death. Where a conflict arises between Centrotherm instructions and these instructions, the more restrictive instructions shall govern.
- **Do not mix vent components or joining methods for listed manufacturers.**
- **Examine all components for possible shipping damage prior to installation.**
- **All condensate that forms in the vent must be able to drain back to the boiler.**

2. Assemble the vent system, starting at the boiler:

- a. Vent adaptors accept InnoFlue vent pipe as is. The 3" adaptor used on the 120-180 has two different diameter vent gaskets. The lower gasket accepts 3" InnoFlue. Lubricate the gasket on the vent adaptor (lubricate the lower gasket on the 3" adaptor) with soapy water and insert the first piece of InnoFlue into the adaptor until it bottoms out. Tighten the gear clamp on the adaptor.

NOTICE

Once a vent pipe is inserted into this adaptor, it is IMPOSSIBLE to remove it. Make sure the correct type of pipe is selected, and that it is of the correct length, before inserting it into the vent adaptor.

- b. If an 80 or 100 is to be used with 3" venting, insert a short (less than 30") length of 2" straight pipe and then install a Centrotherm #ISIA0203 2 x 3" increaser or ISEI0203 eccentric 2 x 3" increaser. If the ISIA0203 increaser is used, it must be installed in the first vertical run of pipe at the boiler to prevent condensate from becoming trapped at the reduction. The ISEI0203 eccentric increaser may be installed in a horizontal run as long as the "straight" side of this increaser is on the bottom.
- c. For each joint, verify that the gasket is evenly seated in the bell (female) end of the pipe. Lubricate this gasket with Centrocerin # IACE50. Slide a connector ring over the male end of the pipe to be joined as shown in Figure 7.44. Push the male end of the next section of pipe into the bell until it bottoms out, then back out 1/4" to provide room for thermal expansion. Push hook on connecting ring over the bell end of the first section of pipe as shown in Figure 7.44.
- d. Assemble the rest of the vent system per the manufacturer's installation instructions, being sure to pitch horizontal sections back towards the boiler 5/8"/ft.
- e. Support each horizontal pipe section with a minimum of one wall strap each and at intervals not exceeding 39in.

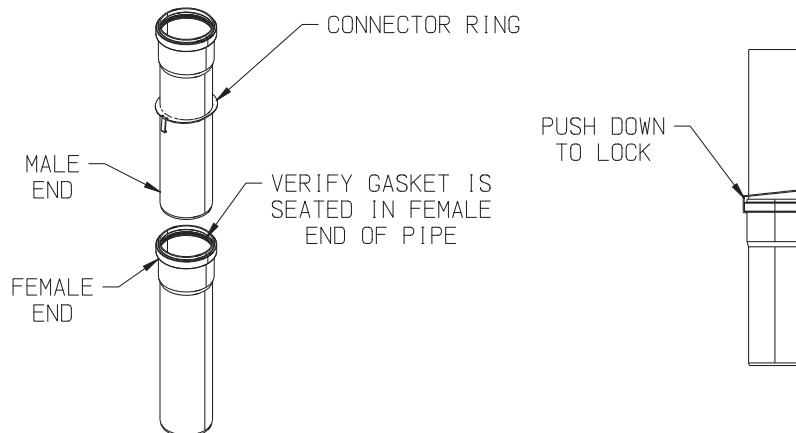

FIGURE 7.44: INNOFLUE CONNECTOR RING INSTALLATION

3. Installation of Air Intake System - Start assembly of the PVC air intake system at the boiler. Assembly of the air intake system is done in the same manner as a CPVC/PVC vent system except as follows:
 - a. Drill a 7/32" clearance hole into the front side of the air intake adapter. Insert the first piece of PVC air intake pipe into the air intake connection and drill a 1/8" tap hole into the PVC which lines up with the 7/32" clearance hole and secure them together with a #10 x 1" sheet metal screw. Seal the joint between the intake pipe and the adaptor with RTV.
 - b. All intake piping may be PVC.
 - c. There is a 0" minimum clearance between the air intake piping and all types of construction.
 - d. To the extent possible, pitch horizontal air intake piping towards the outside.



WARNING

Asphyxiation Hazard. Vent systems made by Centrotherm rely on gaskets for proper sealing. When this vent system is used, take the following precautions:

- **Make sure that gasket is in position and undamaged in the female end of the pipe.**
- **Make sure that both the male and female pipes are free of damage prior to assembly.**
- **Only cut vent pipe as permitted by the vent manufacturer in accordance with their instructions. When pipe is cut, the cut end must be square and carefully de-burred prior to assembly.**
- **Use connector rings at all vent pipe joints.**

NOTICE

The venting system must be free to expand and contract and supported in accordance with the installation instructions included by the original polypropylene venting component manufacturer, Centrotherm. Polypropylene pipe sections must be disengaged 1/4 in. (5mm) per joint to allow for thermal expansion.

4. Installation of Horizontal Fitting Terminals (Terminal Option A):
 - a. See Figure 7.45 for proper orientation of twin pipe horizontal terminals. Outer edge of end pipe must be 10" or less from the wall surface. (Figure 7.5)
 - b. Use plain end UV stabilized Centrotherm 2" pipe # ISEP02 or ISEP0239 or 3" pipe # ISEP03 or ISEP0339 and insert Centrotherm Bird Screen #IASPP02 or #IASPP03 in the end of the pipe.
 - c. Add PVC intake per instructions from Part VII-F.
5. Installation of Vertical Fitting Terminals (Terminal Option H):
 - a. See Figure 7.46 for the proper orientation of twin pipe vertical terminals.
 - b. Use plain end UV stabilized Centrotherm 2" pipe # ISEP02 or ISEP0239 or 3" pipe # ISEP03 or ISEP0339 and insert Centrotherm Bird Screen #IASPP02 or #IASPP03 in the end of the pipe.
 - c. A 180° bend (or two 90° elbows) are installed on the top of the air intake pipe. If two 90° elbows are used, the rodent screen provided can be installed between them (Figure 7.46). If a 180° bend is used, install the rodent screen in the open side of the bend, using a ring made of PVC pipe. If desired, the termination fittings can be attached to the end of the intake pipes with field supplied stainless steel screws so that they can be later removed for cleaning and inspection. If this is done, drill a clearance hole in these fittings and a tap hole in the end of the intake pipes to accept these screws.
 - d. Use roof flashings and storm collars to prevent moisture from entering the building. Seal the roof flashing to the roof using generally accepted practice for the type of roof on the installation. Apply RTV to seal the storm collars to the vent and intake pipes.

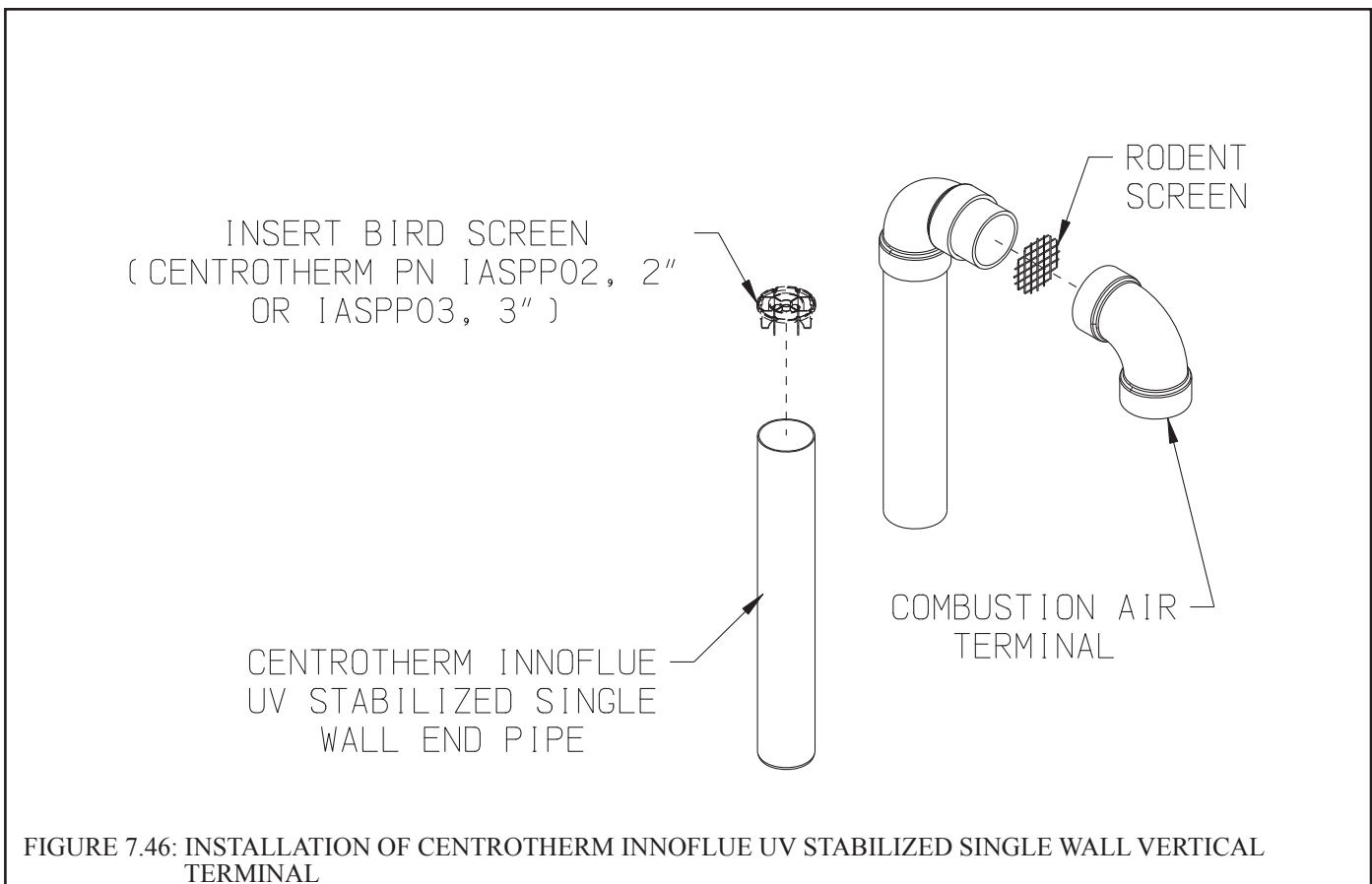
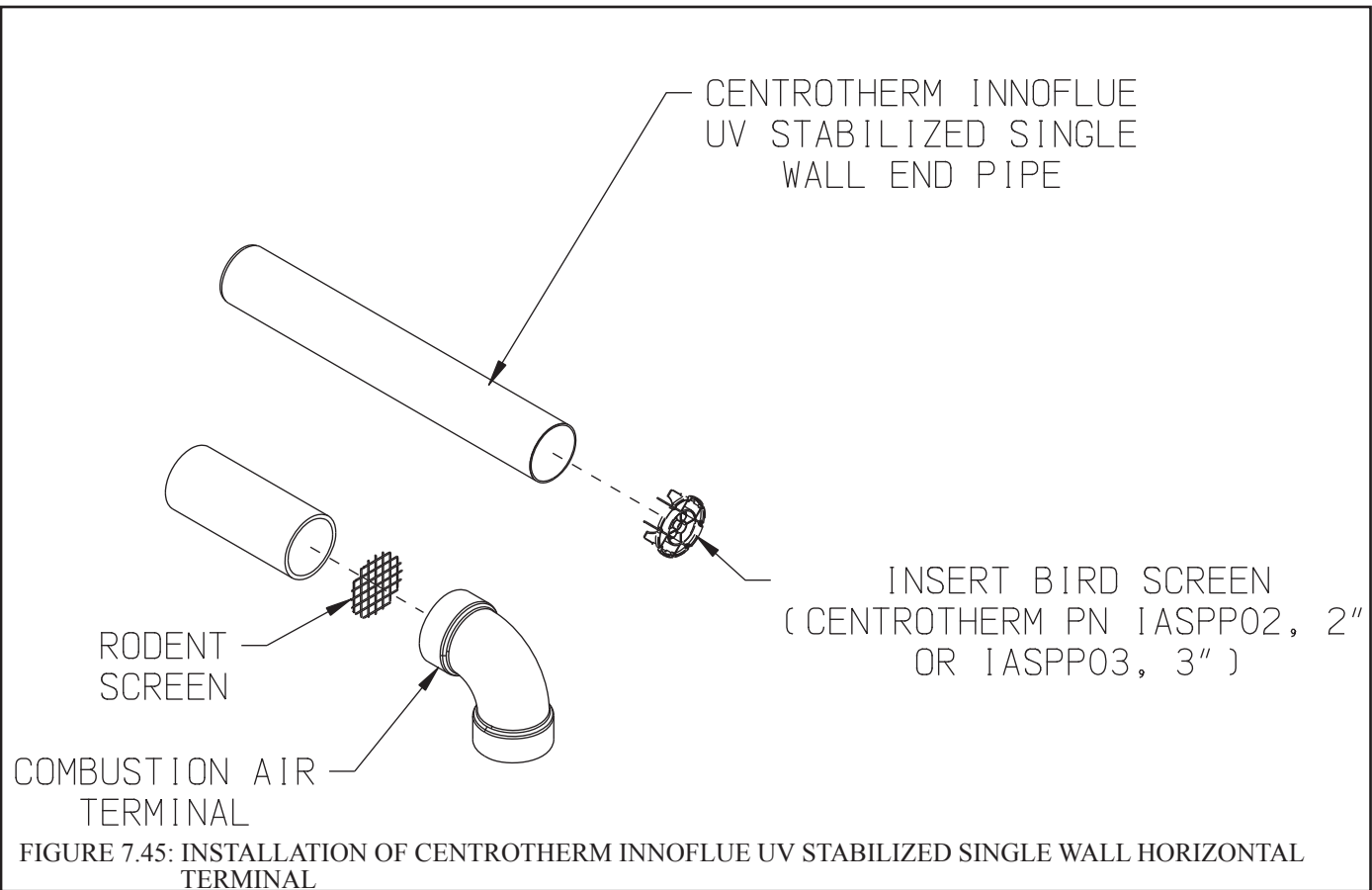

6. Installations using InnoFlue Flex (Vent Options 20,21,37,38):



WARNING

Asphyxiation Hazard. When using InnoFlue Flex, observe the following precautions:

- **InnoFlue Flex may be damaged by handling at low temperatures. Do not bend, uncoil, or attempt to install if it has been stored at a temperature below 42F without allowing it to warm to a higher temperature first.**
- **Do not bend InnoFlue Flex more than 45 degrees.**
- **Instructions below reference the Centrotherm InnoFlue instruction manual. Not all vent configurations shown in the Centrotherm manual are approved for use with this boiler.**

Refer to Centrotherm InnoFlue Instructions for assembly of all flex components including the chimney cap and the adaptor to rigid InnoFlue at the base of the masonry or B vent chimney. In addition, observe the following requirements:

- a) Refer to the appropriate Vent option in Tables 7.13b or 7.21 for a list of the principle flex components required. Rigid vent pipe by the same manufacturer will also be required for the run from the boiler to the base of chimney.
- b) Masonry chimneys cannot be used for an air chase
- c) B vent chimneys can only be used for an air chase (Vent options 20, 21) if the B vent has the minimum size shown in Table 7.13b and is fully accessible for sealing of all joints and seams.
- d) When Vent Options 20, 21 are used, install a Tee of the same size at the base of the vent. Route the smooth section of InnoFlue Flex (3") or Flex Adaptor (2") through a cap in the base of this Tee. Use a Centrotherm IAWP2P or IAWP03B wall plate and RTV to seal this penetration. Install the Base Support using the Base support bracket as described in the InnoFlue installation manual.

Connection of the PVC air intake pipe to the side outlet of the tee is made using a cap and a PVC socket x male thread adaptor (2" or 3", depending on the Vent Option). Cut a clearance hole in the cap for the male threads. Secure the adaptor to the cap using a 2" or 3" electrical conduit lock nut. Seal all joints with RTV.

I. Condensate Trap and Drain Line

All condensate which forms in the boiler or vent system passes through the heat exchanger and out of a bottom drain port which is connected to the condensate trap with a hose. This trap allows condensate to drain from the heat exchanger while retaining flue gases in the boiler. This trap is an integral part of the boiler but must be connected to a drain pipe as shown in Figure 7.47. A length of corrugated tubing is supplied with the boiler and is connected to the trap as shown in Figure 7.35. Note the following when disposing of the condensate:

1. If the corrugated condensate drain line must be extended, construct the extension from PVC or CPVC pipe. Insert the hose provided with the boiler into the end of the extension as shown in Figure 7.47.
2. Condensate is slightly acidic. Do not use metallic pipe or fittings in the condensate drain line. Do not route the drain line through areas that could be damaged by leaking condensate.
3. Some jurisdictions may require that the condensate be neutralized before being disposed of. Dispose of condensate in accordance with local codes.
4. Do not route, or terminate, the condensate drain line in areas subjected to freezing temperatures.
5. If the point of condensate disposal is above the trap, it will be necessary to use a condensate pump to move the condensate to the drain. In such cases, select a condensate pump that is approved for use with condensing boilers. If overflow from this pump would result in property damage, select a pump with an overflow switch and use this switch to shut down the boiler. Alternatively, if heat is a necessity, use the overflow switch to trigger an alarm.
6. Do not attempt to move the trap from the location shown in Figure 7.47. Do not attempt to substitute another trap for the one provided with the boiler.
7. The vent shown in Figure 7.47 must be left open for the trap to work properly.



WARNING

Asphyxiation Hazard. Failure to install the condensate drain in accordance with the above instructions could cause flue gas to enter the building, resulting in personal injury or death.

NOTICE

- **Boiler condensate is corrosive. Route condensate drain line in a manner such that any condensate leakage will not cause property damage.**
- **Some jurisdictions may require that condensate be neutralized prior to disposal.**
- **Use materials approved by the authority having jurisdiction.**

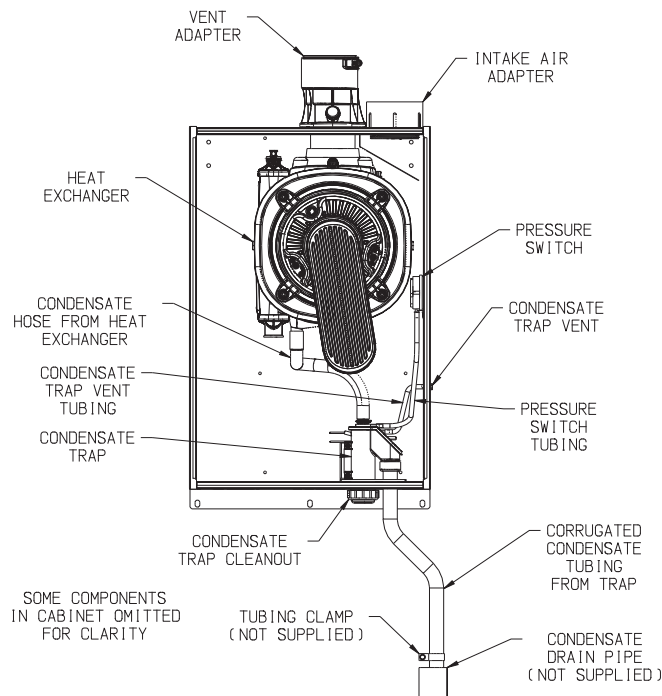

FIGURE 7.47: CONDENSATE PIPING ARRANGEMENT

J. Removing an Existing Boiler From a Common Chimney

This section only applies if this boiler is replacing an existing boiler that is being removed from a common chimney.

In some cases, when an existing boiler is removed from a common chimney, the common venting system may be too large for the remaining appliances. At the time of removal of an existing boiler, the following steps shall be followed with each appliance remaining connected to the common venting system placed in operation, while the other appliances remaining connected to the common venting system are not in operation.

- (a) Seal any unused openings in the common venting system.
- (b) Visually inspect the venting system for proper size and horizontal pitch and determine there is no blockage or restriction, leakage, corrosion and other deficiencies which could cause an unsafe condition.
- (c) Insofar as practical, close all building doors and windows and all doors between the space in which all the appliances remaining connected to the common venting system are located and other spaces of the building. Turn on clothes dryers and any appliance not connected to the common venting system. Turn on any exhaust fans, such as range hoods and bathroom exhausts, so they will operate at maximum speed. Do not operate a summer exhaust fan. Close fireplace dampers.
- (d) Place in operation the appliance being inspected. Follow the lighting instructions. Adjust thermostat so the appliance will operate continuously.
- (e) Test for spillage at the draft hood relief opening after 5 minutes of main burner operation. Use the flame of a match or candle, or smoke from a cigarette, cigar, or pipe.
- (f) After it has been determined that each appliance remaining connected to the common venting system properly vents when tested as outlined above, return doors, windows, exhaust fans, fireplace dampers and any other gas-burning appliances to their previous condition of use.
- (g) Any improper operation of the common venting system should be corrected so the installation conforms with the National Fuel Gas Code, ANSI Z223.1. When re-sizing any portion of the common venting system, the common venting system should be re sized to approach the minimum size as determined using the appropriate tables in Part 11 of the National Fuel Gas Code, ANSI Z223.1.



WARNING

Never common vent this boiler with other appliances.

Au moment du retrait d'une chaudière existante, les mesures suivantes doivent être prises pour chaque appareil toujours raccordé au système d'évacuation commun et qui fonctionne alors que d'autres appareils toujours raccordés au système d'évacuation ne fonctionnent pas:

- (a) Sceller toutes les ouvertures non utilisées du système d'évacuation.
- (b) Inspecter de façon visuelle le système d'évacuation pour déterminer la grosseur et l'inclinaison horizontale qui conviennent et s'assurer que le système est exempt d'obstruction, d'étranglement, de fuite, de corrosion et autres défaillances qui pourraient présenter des risques.
- (c) Dans la mesure du possible, fermer toutes les portes et les fenêtres du bâtiment et toutes les portes entre l'espace où les appareils toujours raccordés au système d'évacuation sont installés et les autres espaces du bâtiment. Mettre en marche les sècheuses, tous les appareils non raccordés au système d'évacuation commun et tous les ventilateurs d'extraction comme les hottes de cuisinière et les ventilateurs des salles de bain. S'assurer que ces ventilateurs fonctionnent à la vitesse maximale. Ne pas faire fonctionner les ventilateurs d'été. Fermer les registres des cheminées.
- (d) Mettre l'appareil inspecté en marche. Suivre les instructions d'allumage. Régler le thermostat de façon que l'appareil fonctionne de façon continue.
- (e) Faire fonctionner le brûleur principal pendant 5 min ensuite, déterminer si le coupe-tirage déborde à l'ouverture de décharge. Utiliser la flamme d'une allumette ou d'une chandelle ou la fumée d'une cigarette, d'un cigare ou d'une pipe.
- (f) Une fois qu'il a été déterminé, selon la méthode indiquée ci-dessus, que chaque appareil raccordé au système d'évacuation est mis à l'air libre de façon adéquate. Remettre les portes et les fenêtres, les ventilateurs, les registres de cheminées et les appareils au gaz à leur position originale.
- (g) Tout mauvais fonctionnement du système d'évacuation commun devrait être corrigé de façon que l'installation soit conforme au National Fuel Gas Code, ANSI Z223.1/NFPA 54 et (ou) aux codes d'installation CAN/CSA-B149.1. Si la grosseur d'une section du système d'évacuation doit être modifiée, le système devrait être modifié pour respecter les valeurs minimales des tableaux pertinents de l'appendice F du National Fuel Gas Code, ANSI Z223.1/NFPA 54 et (ou) des codes d'installation CAN/CSA-B149.1.

Appendix A: Special Requirements For Side-Wall Vented Appliances In The Commonwealth of Massachusetts

IMPORTANT

The Commonwealth of Massachusetts requires compliance with regulation 248 CMR 4.00 and 5.00 for installation of side-wall vented gas appliances as follows:

(a) For all side wall horizontally vented gas fueled equipment installed in every dwelling, building or structure used in whole or in part for residential purposes, including those owned or operated by the Commonwealth and where the side wall exhaust vent termination is less than seven (7) feet above finished grade in the area of the venting, including but not limited to decks and porches, the following requirements shall be satisfied:

1. **INSTALLATION OF CARBON MONOXIDE DETECTORS.** At the time of installation of the side wall horizontal vented gas fueled equipment, the installing plumber or gasfitter shall observe that a hard wired carbon monoxide detector with an alarm and battery back-up is installed on the floor level where the gas equipment is to be installed. In addition, the installing plumber or gasfitter shall observe that a battery operated or hard wired carbon monoxide detector with an alarm is installed on each additional level of the dwelling, building or structure served by the side wall horizontal vented gas fueled equipment. It shall be the responsibility of the property owner to secure the services of qualified licensed professionals for the installation of hard wired carbon monoxide detectors.

- a. In the event that the side wall horizontally vented gas fueled equipment is installed in a crawl space or an attic, the hard wired carbon monoxide detector with alarm and battery back-up may be installed on the next adjacent floor level.
- b. In the event that the requirements of this subdivision can not be met at the time of completion of installation, the owner shall have a period of thirty (30) days to comply with the above requirements; provided, however, that during said thirty (30) day period, a battery operated carbon monoxide detector with an alarm shall be installed.

2. **APPROVED CARBON MONOXIDE DETECTORS.** Each carbon monoxide detector as required in accordance with the above provisions shall comply with NFPA 720 and be ANSI/UL 2034 listed and IAS certified.

3. **SIGNAGE.** A metal or plastic identification plate shall be permanently mounted to the exterior of the building at a minimum height of eight (8) feet above grade directly in line with the exhaust vent terminal for the horizontally vented gas fueled heating appliance or equipment. The sign shall read, in print size no less than one-half (1/2) inch in size, "GAS VENT DIRECTLY BELOW. KEEP CLEAR OF ALL OBSTRUCTIONS".

4. **INSPECTION.** The state or local gas inspector of the side wall horizontally vented gas fueled equipment shall not approve the installation unless, upon inspection, the inspector observes carbon monoxide detectors and signage installed in accordance with the provisions of 248 CMR 5.08(2)(a)1 through 4.

(b) **EXEMPTIONS:** The following equipment is exempt from 248 CMR 5.08(2)(a)1 through 4:

1. The equipment listed in Chapter 10 entitled "Equipment Not Required To Be Vented" in the most current edition of NFPA 54 as adopted by the Board; and
2. Product Approved side wall horizontally vented gas fueled equipment installed in a room or structure separate from the dwelling, building or structure used in whole or in part for residential purposes.

(c) **MANUFACTURER REQUIREMENTS - GAS EQUIPMENT VENTING SYSTEM PROVIDED.** When the manufacturer of Product Approved side wall horizontally vented gas equipment provides a venting system design or venting system components with the equipment, the instructions provided by the manufacturer for installation of the equipment and the venting system shall include:

1. Detailed instructions for the installation of the venting system design or the venting system components; and
2. A complete parts list for the venting system design or venting system.

(d) MANUFACTURER REQUIREMENTS - GAS EQUIPMENT VENTING SYSTEM NOT PROVIDED. When the manufacturer of a Product Approved side wall horizontally vented gas fueled equipment does not provide the parts for venting the flue gases, but identifies “special venting systems”, the following requirements shall be satisfied by the manufacturer:

1. The referenced “special venting system” instructions shall be included with the appliance or equipment installation instructions; and
2. The “special venting systems” shall be Product Approved by the Board, and the instructions for that system shall include a parts list and detailed installation instructions.

(e) A copy of all installation instructions for all Product Approved side wall horizontally vented gas fueled equipment, all venting instructions, all parts lists for venting instructions, and/or all venting design instructions shall remain with the appliance or equipment at the completion of the installation.

Velocity Boiler Works, LLC
P.O. Box 14818
3633 I Street
Philadelphia, PA 19134
www.velocityboilerworks.com