

ELECTRIC AIR HANDLERS FOR 7½ & 10-TON SPLIT SYSTEMS



■ Contents

Nomenclature	2
Product Specifications	3
Airflow Data	4
Heating Kit Data	6
Dimensions.....	7
Wiring Diagrams	8

■ Standard Features

- Uplflow or horizontal (left side) installation positions in 7½ and 10-ton cooling only or heat pump applications
- Circuited for use with one (1) 7½-ton or one (1) 10-ton cooling-only or heat pump system. Also circuited for use with two (2) 4-ton or two (2) 5-ton cooling-only units
- TXV Control; Units have two (2) thermal expansion valves
- DAT units feature a 2-speed blower motor
- Draw-thru centrifugal blower is belt driven for quiet, efficient operation
- Copper tube/aluminum fin coils
- Horizontal and vertical condensate pans
- AHRI Certified; ETL Listed

■ Cabinet Features

- Heavy-gauge, reinforced, galvanized-steel cabinet
- Fully insulated with fiberglass blanket
- Horizontal and vertical condensate pans
- Built-in filter rack (2" filter included)
- Entry on top of panel for both low and high voltage
- Removable access panels make servicing of unit faster and easier



* Complete warranty details available from your local dealer or at www.daikincomfort.com.

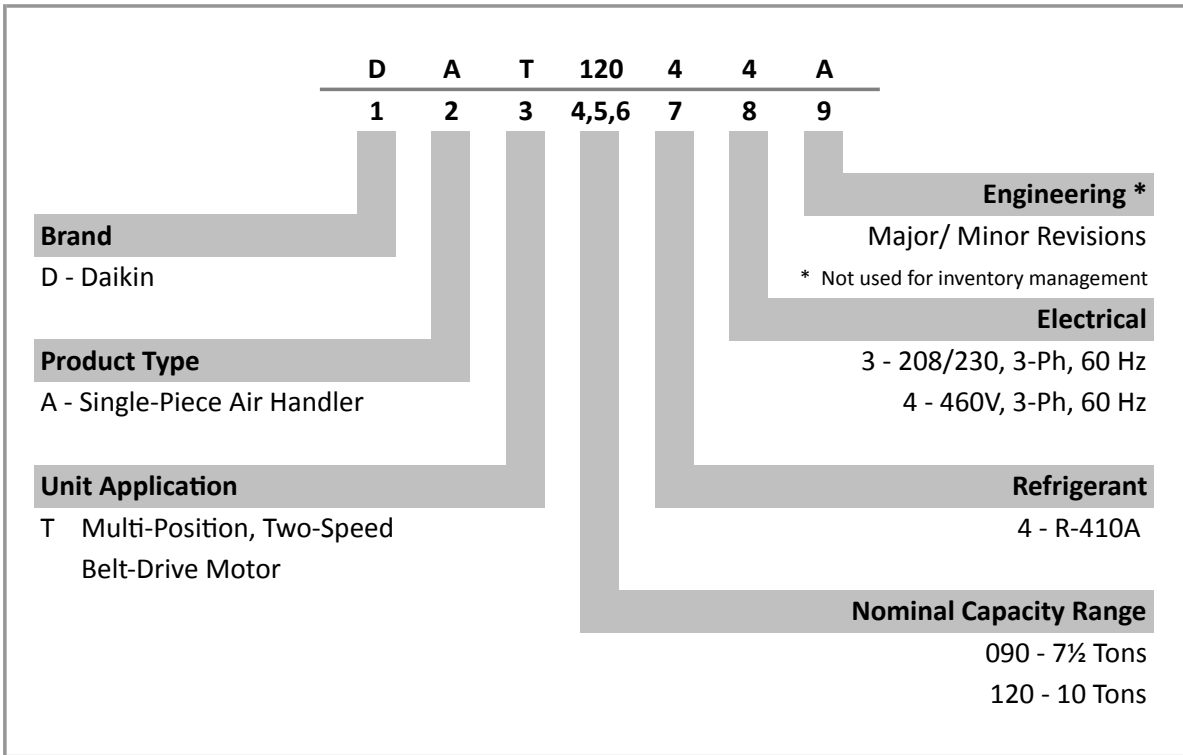

	DAT09043**	DAT09044**	DAT12043**	DAT12044**
TOTAL CAPACITIES				
Cooling (BTU/h)	90,000	90,000	120,000	120,000
Heating (kW)	15, 20, 30	15, 20, 30	15, 20, 30	15, 20, 30
CFM	3,000	3,000	4,000	4,000
ELECTRICAL DATA				
Voltage-Hz-Phase	208/240-60-3	460-60-3	208/240-60-3	460-60-3
Voltage Range	187 - 253	414-506	187 - 253	414-506
FLA (Total)	6.0	2.9	6.0	2.9
Minimum Circuit Ampacity	7.5	3.63	7.5	3.63
BLOWER MOTOR				
Type	Belt Drive	Belt Drive	Belt Drive	Belt Drive
Horse Power	2	2	2	2
Voltage-Hz-Phase	208/240-60-3	460-60-3	208/240-60-3	460-60-3
FLA/ LRA	6.0/47.7	2.9/23.9	6.0/47.7	2.9/23.9
BLOWER & CONTROLS				
Wheel Dia. & Width (Qty.)	11 x 10 (2)	11 x 10 (2)	11 x 10 (2)	11 x 10 (2)
Pulley Pitch Dia.	6.5"	6.5"	6.5"	6.5"
Bore	1"	1"	1"	1"
Motor Pulley Pitch Dia.	1.9 to 2.9	1.9 to 2.9	2.8 to 3.8	2.8 to 3.8
Bore	3/8"	3/8"	3/8"	3/8"
Belt Length & Width	41 x 1/2	41 x 1/2	41 x 1/2	41 x 1/2
Nominal Airflow (Ft./Min.)	3,000	3,000	4,000	4,000
Transformer	Standard	Standard	Standard	Standard
Blower Relay	Standard	Standard	Standard	Standard
FILTER, COIL & REFRIGERANT				
Disposable Filter Size / Qty	16"x20"x2"/ 2 20"x20"x2"/ 2	16"x20"x2"/ 2 20"x20"x2"/ 2	16"x20"x2"/ 2 20"x20"x2"/ 2	16"x20"x2"/ 2 20"x20"x2"/ 2
Coil Area (sq. ft.)	10	10	10	10
FPI - Rows	14 - 4	14 - 4	14 - 4	14 - 4
Expansion Valve Qty.	2	2	2	2
Refrigerant	R-410A	R-410A	R-410A	R-410A
Liquid Connection (Qty.)	3/8" (2) *	3/8" (2) *	3/8" (2) *	3/8" (2) *
Suction Connection (Qty.)	1 1/8" (2)	1 1/8" (2)	1 1/8" (2) *	1 1/8" (2) *
Condensate Drain	3/4 FPT	3/4 FPT	3/4 FPT	3/4 FPT
SHIP WEIGHT (LBS)	430	430	430	430

* For two refrigerant lines

DAT0904 (HIGH SPEED)**

STATIC PRESSURE	MOTOR SHEAVE TURNS OPEN				
	0	1	2	3	4
0.1	---	---	---	---	---
0.2	---	---	---	---	3246
0.3	---	---	---	3194	2941
0.4	---	---	3393	2871	2561
0.5	---	---	3027	2482	2133
0.6	---	3139	2710	2137	---
0.7	3276	2757	2217	---	---
0.8	2866	2255	---	---	---
0.9	2458	1832	---	---	---

DAT1204 (HIGH SPEED)**

STATIC PRESSURE	MOTOR SHEAVE TURNS OPEN					
	0	1	2	3	4	5
0.1	---	---	---	---	4472	4134
0.2	---	---	---	---	4119	3776
0.3	---	---	---	4322	3936	3561
0.4	---	---	4406	3955	3683	3304
0.5	---	4427	4026	3761	3402	2959
0.6	---	4265	3845	3422	3094	2581
0.7	4347	3899	3618	3100	2722	---
0.8	3964	3594	3266	2742	2512	---
0.9	3710	3233	2835	2470	---	---

* With dry coil and 2" air filter

NOTES:

- Any adjustment made to the blower should not cause the motor to draw more than the motors rated RLA.
- Applications that exceed the above could require a larger motor.

MODEL	HEAT KIT kW	CFM	SUPPLY VOLTAGE		
			208	240	480
DAT0904**	15	2,800	14	19	19
		2,900	14	18	18
		3,000	13	18	18
		3,100	13	17	17
		3,200	12	17	17
	20	2,800	19	25	25
		2,900	18	24	24
		3,000	18	24	24
		3,100	17	23	23
		3,200	17	22	22
	30	2,800	28	38	38
		2,900	27	37	37
		3,000	27	35	35
		3,100	26	34	34
		3,200	25	33	33

MODEL	HEAT KIT kW	CFM	SUPPLY VOLTAGE		
			208	240	480
DAT1204**	15	3,800	10	14	14
		3,900	10	14	14
		4,000	10	13	13
		4,100	10	13	13
		4,200	9	13	13
	20	3,800	14	19	19
		3,900	14	18	18
		4,000	13	18	18
		4,100	13	17	17
		4,200	13	17	17
	30	3,800	21	28	28
		3,900	20	27	27
		4,000	20	27	27
		4,100	19	26	26
		4,200	19	25	25

* Tables above are calculated with both stages of electric heat engaged (2-stage heat systems). Divide the temperature rise from the table by 2 for 1st stage operation for systems using staged electric heat.

AIR HANDLER	AHKD MODEL	NOMINAL kW	ELECTRICAL DATA	STAGES	WEIGHT (LBS.)	MCA ¹	MOP ²
DAT0904**	AHKD15-3	15	208-230/3/60	1	56	50	50
	AHKD15-4	15	460/3/60	1	55	25	25
	AHKD20-3	20	208-230/3/60	2	59	64	70
	AHKD20-4	20	460/3/60	2	57	32	35
	AHKD30-3	30	208-230/3/60	2	60	93	100
	AHKD30-4	30	460/3/60	2	58	47	50
DAT1204**	AHKD15-3	15	208-230/3/60	1	56	53	60
	AHKD15-4	15	460/3/60	1	55	27	30
	AHKD20-3	20	208-230/3/60	2	59	68	70
	AHKD20-4	20	460/3/60	2	57	34	35
	AHKD30-3	30	208-230/3/60	2	60	96	100
	AHKD30-4	30	460/3/60	2	58	48	50

¹ Minimum Circuit Ampacity

² Maximum Overcurrent Protection

NOTES:

- These air handlers do not have factory-installed electric heat. The above-listed kits are the ONLY heater kits that can be used with this commercial series. They are available for purchase as field-installed accessories.
- The electrical characteristics of the air handler, electric heater kits, and building power supply must be compatible.

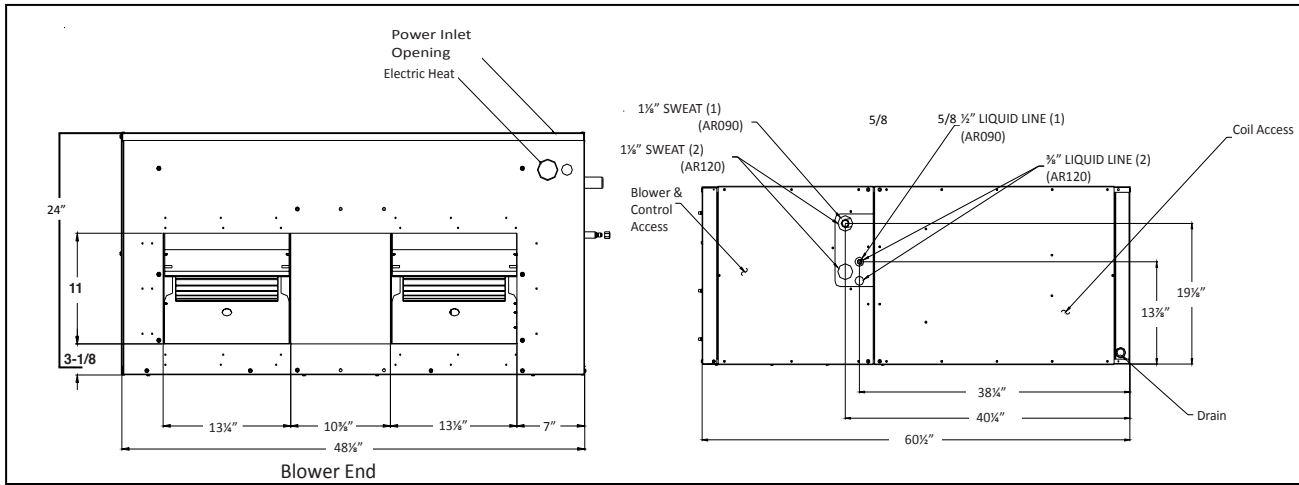

Note: DAT090A (1) 5/8" Liquid Line DAT120A (2) 3/8" Liquid Line

DUCT CONNECTION SIZING WITHOUT ELECTRIC HEATERS

MINIMUM SUPPLY AND RETURN DUCT DIMENSIONS

DIMENSIONAL DATA FOR ELECTRIC HEATER KITS

- 15, 20, & 30 kW Heater Kits
- Supply opening is 13 3/8" x 40 1/8"

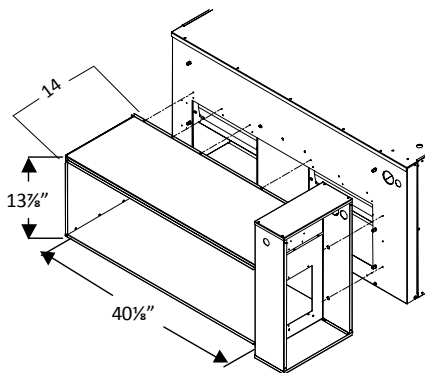

SUPPLY DUCT		RETURN DUCT	
A	B	C	D
13 3/8"	40"	24"	48"

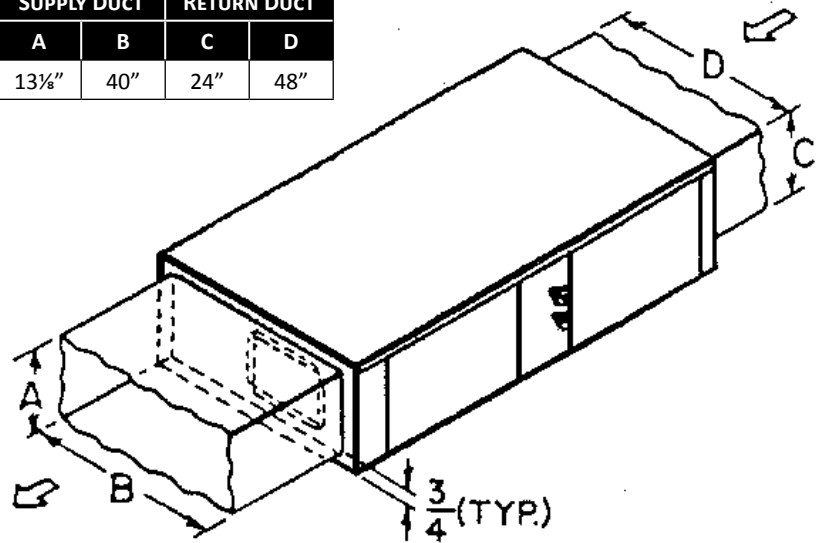

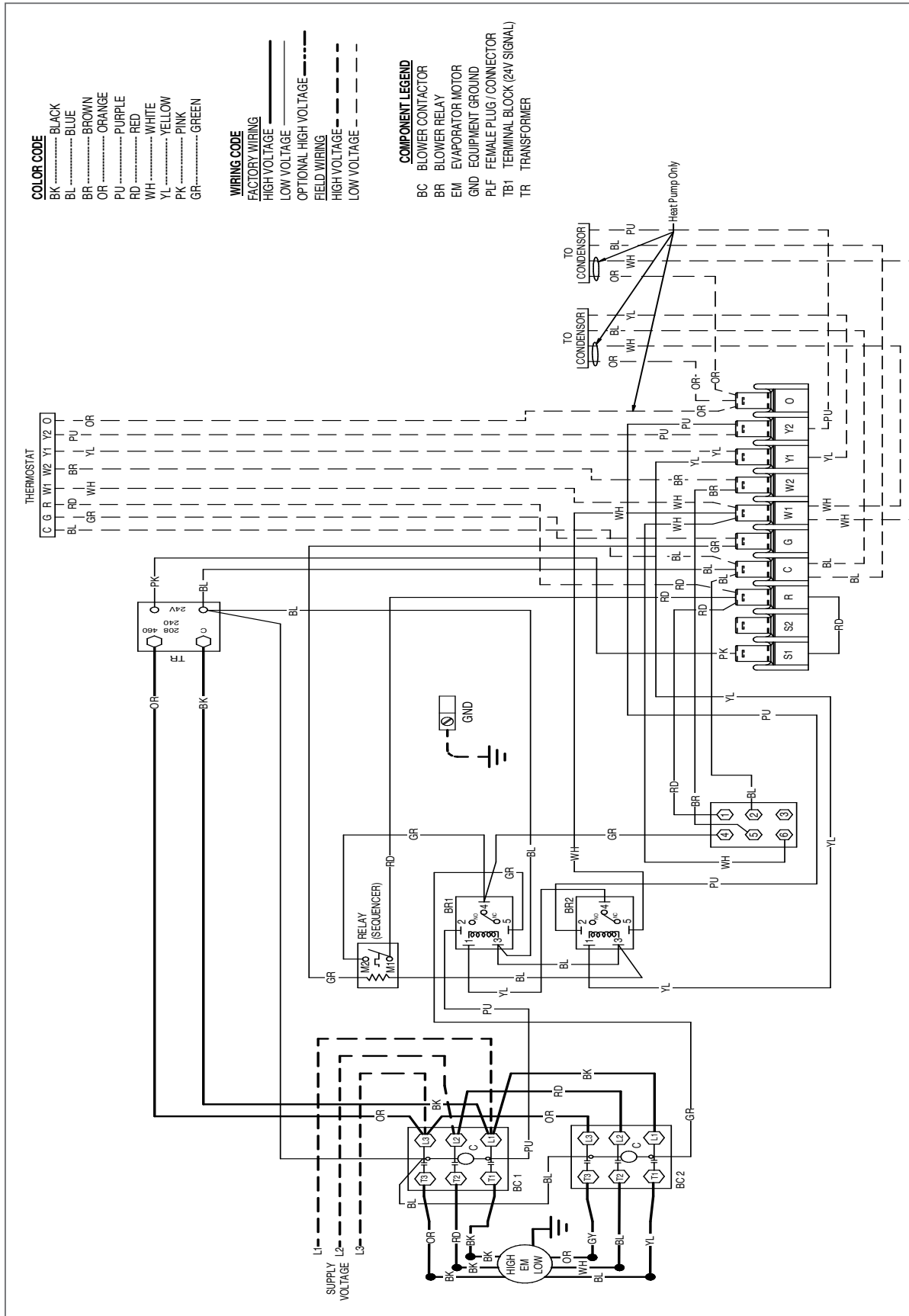

Wiring is subject to change. Always refer to the wiring diagram on the unit for the most up-to-date wiring.



WARNING

High Voltage: Disconnect all power before servicing or installing this unit. Multiple power sources may be present. Failure to do so may cause property damage, personal injury, or death.

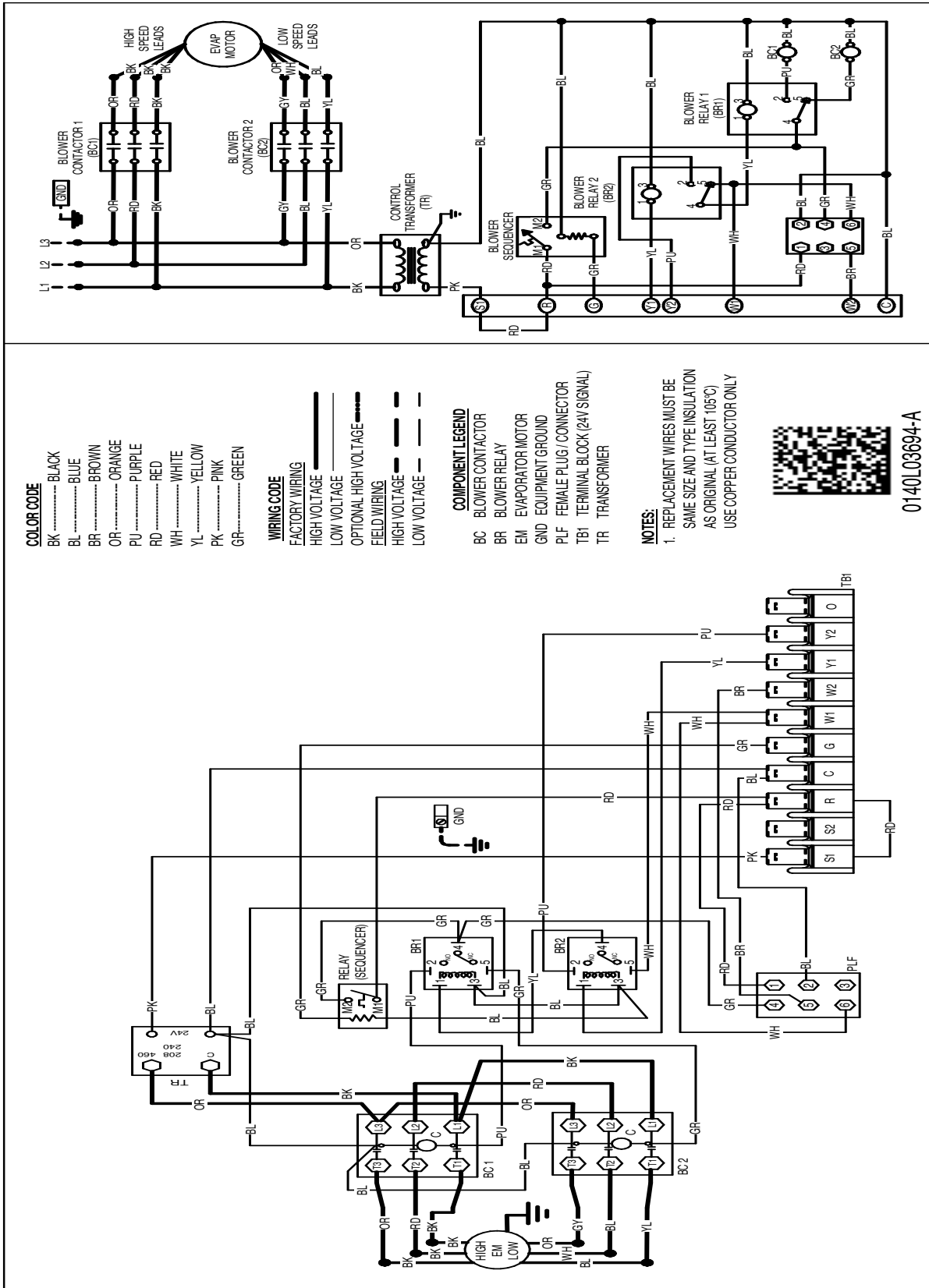

Wiring is subject to change. Always refer to the wiring diagram on the unit for the most up-to-date wiring.

WARNING

High Voltage: Disconnect all power before servicing or installing this unit. Multiple power sources may be present. Failure to do so may cause property damage, personal injury, or death.

