



Home Generator Systems

Operator's Manual



Home Generator System



Thank you for purchasing this quality-built Briggs & Stratton home generator. We're pleased that you've placed your confidence in the Briggs & Stratton brand. When operated and maintained according to the instructions in this manual, your home generator will provide many years of dependable service.

This manual contains safety information to make you aware of the hazards and risks associated with home standby generators and how to avoid them. Because we do not necessarily know all the applications this equipment could be used for, it is important that you read and understand these instructions thoroughly before attempting to start or operate this equipment. **Save these original instructions for future reference.**

This home generator requires professional installation before use. Refer to the separate installation manual for full information. Your installer should follow the instructions completely.

Where to Find Us

You never have to look far to find Briggs & Stratton support and service for your generator. Consult your Yellow Pages. There are many Briggs & Stratton authorized service dealers worldwide who provide quality service. You can also contact Technical Service by phone at **(800) 743-4115**, or click on Find a Dealer at BRIGGSandSTRATTON.COM, which provides a list of authorized dealers.

Generator and engine model and serial numbers should be recorded in the Installation Manual.

Not for
Reproduction

Briggs & Stratton Power Products Group, LLC
P.O. Box 702
Milwaukee, WI 53201-0702

Copyright © 2010. All rights reserved. No part of this material may be reproduced or transmitted in any form without the express written permission of Briggs & Stratton Power Products Group, LLC.

Table of Contents

Important Safety Instructions	4
Installation	7
Owner Orientation	7
Fuel Factors	8
Delivery Inspection	9
Controls	10
Home Generator	10
System Control Panel	11
Access Ports	12
Operation	12
Engine Oil	12
Battery	12
15 Amp Fuse	13
Automatic Operation	13
Setting Exercise Timer	13
Maintenance	14
Fault Detection System	14
Engine Oil	16
Battery	16
Cleaning the Generator	17
Troubleshooting	18
Warranty	19
Product Specifications	20

Not for
Reproduction

Save These Instructions

Important Safety Instructions

SAVE THESE INSTRUCTIONS - This manual contains important instructions that should be followed during installation and maintenance of the generator and batteries.

Safety Symbols and Meanings



Explosion



Fire



Electrical Shock



Toxic Fumes



Rotating Parts



Hot Surface



Auto Start



Explosive Pressure



Chemical Burn



Lift Hazard



Read Manual

▲ The safety alert symbol indicates a potential personal injury hazard. A signal word (DANGER, WARNING, or CAUTION) is used with the alert symbol to designate a degree or level of hazard seriousness. A safety symbol may be used to represent the type of hazard. The signal word *NOTICE* is used to address practices not related to personal injury.

▲ DANGER indicates a hazard which, if not avoided, *will* result in death or serious injury.

▲ WARNING indicates a hazard which, if not avoided, *could* result in death or serious injury.

▲ CAUTION indicates a hazard which, if not avoided, *could* result in minor or moderate injury.

NOTICE addresses practices not related to personal injury.

The manufacturer cannot possibly anticipate every possible circumstance that might involve a hazard. The warnings in this manual, and the tags and decals affixed to the unit are, therefore, not all-inclusive. If you use a procedure, work method or operating technique that the manufacturer does not specifically recommend, you must satisfy yourself that it is safe for you and others. You must also make sure that the procedure, work method or operating technique that you choose does not render the generator system unsafe.

▲ WARNING Running engine gives off carbon monoxide, an odorless, colorless, poison gas. Breathing carbon monoxide can cause headache, fatigue, dizziness, vomiting, confusion, seizures, nausea, fainting or death.

- Operate generator **ONLY** outdoors.
- Install a battery operated carbon monoxide alarm near the bedrooms.
- Keep exhaust gas from entering a confined area through windows, doors, ventilation intakes, or other openings.

▲ WARNING The engine exhaust from this product contains chemicals known to the State of California to cause cancer, birth defects, or other reproductive harm.

▲ WARNING Certain components in this product and related accessories contain chemicals known to the State of California to cause cancer, birth defects, or other reproductive harm. Wash hands after handling.

▲ WARNING Storage batteries give off explosive hydrogen gas during recharging. Slightest spark will ignite hydrogen and cause explosion. Battery electrolyte fluid contains acid and is extremely caustic.

Contact with battery contents will cause severe chemical burns. A battery presents a risk of electrical shock and high short circuit current.

- DO NOT dispose of battery in a fire. Recycle battery.
- DO NOT allow any open flame, spark, heat, or lit cigarette during and for several minutes after charging a battery.
- DO NOT open or mutilate the battery.
- Wear protective goggles, rubber apron, rubber boots and rubber gloves.
- Remove watches, rings, or other metal objects.
- Use tools having insulated handles.

▲ WARNING Generator produces hazardous voltage. Failure to properly ground generator can result in electrocution. Failure to isolate generator from power utility can result in death or injury to electric utility workers due to backfeed of electrical energy.



- When using generator for backup power, notify utility company.
- DO NOT touch bare wires or bare receptacles.
- DO NOT use generator with electrical cords which are worn, frayed, bare or otherwise damaged.
- DO NOT handle generator or electrical cords while standing in water, while barefoot, or while hands or feet are wet.
- If you must work around a unit while it is operating, stand on an insulated dry surface to reduce the risk of a shock hazard.
- DO NOT allow unqualified persons or children to operate or service generator.
- In case of an accident caused by electrical shock, immediately shut down the source of electrical power and contact the local authorities. **Avoid direct contact with the victim.**
- Despite the safe design of the home generator, operating this equipment imprudently, neglecting its maintenance or being careless can cause possible injury or death.
- Remain alert at all times while working on this equipment. Never work on the equipment when you are physically or mentally fatigued.
- Before performing any maintenance on the generator, disconnect the battery cable indicated by a **NEGATIVE, NEG** or (-) first. When finished, reconnect that cable last.
- After your system is installed, the generator may crank and start without warning any time there is a power failure. To prevent possible injury, always set the generator's system switch to **OFF**, remove the service disconnect from the disconnect box AND remove the 15 Amp fuse BEFORE working on the equipment.

▲ WARNING Propane and Natural Gas are extremely flammable and explosive. Fire or explosion can cause severe burns or death.



- Install the fuel supply system according to NFPA 37 and other applicable fuel-gas codes.
- Before placing the generator into service, the fuel system lines must be properly purged and leak tested.
- After the generator is installed, you should inspect the fuel system periodically.
- NO leakage is permitted.
- DO NOT operate engine if smell of fuel is present or other explosive conditions exist.
- DO NOT smoke around the generator. Wipe up any oil spills immediately. Ensure that no combustible materials are left in the generator compartment. Keep the area near the generator clean and free of debris.

▲ WARNING Contact with muffler area can result in serious burns. Exhaust heat/gases can ignite combustibles or structures causing a fire.



- DO NOT touch hot parts and AVOID hot exhaust gases.
- Allow equipment to cool before touching.
- DO NOT install the generator closer than 5 feet (1.5m) from any combustibles or structures with combustible walls having a fire resistance rating of less than 1 hour.
- Keep at least minimum distances shown in *General Location Guidelines* to insure for proper generator cooling and maintenance clearances.
- It is a violation of California Public Resource Code, Section 4442, to use or operate the engine on any forest-covered, brush-covered, or grass-covered land unless the exhaust system is equipped with a spark arrester, as defined in Section 4442, maintained in effective working order. Other states or federal jurisdictions may have similar laws. Contact the original equipment manufacturer, retailer, or dealer to obtain a spark arrester designed for the exhaust system installed on this engine.
- Replacement parts must be the same and installed in the same position as the original parts.

▲ WARNING Starter and other rotating parts can entangle hands, hair, clothing, or accessories.



- NEVER operate generator without protective housings, covers, or guards in place.
- DO NOT wear loose clothing, jewelry or anything that may be caught in the starter or other rotating parts.
- Tie up long hair and remove jewelry.
- Before servicing, remove 15 Amp fuse from control panel and disconnect **Negative (NEG or -)** battery cable.

▲ CAUTION Installing the 15A fuse could cause the engine to start.



- Observe that the 15 Amp fuse has been removed from the control panel for shipping.
- DO NOT install this fuse until all plumbing and wiring has been completed and inspected.

▲ CAUTION Excessively high operating speeds increase risk of injury and damage to generator. Excessively low speeds impose a heavy load on generator.

- DO NOT tamper with governed speed. Generator supplies correct rated frequency and voltage when running at governed speed.
- DO NOT modify generator in any way.

NOTICE Exceeding generators wattage/amperage capacity can damage generator and/or electrical devices connected to it.

- Start generator and let engine stabilize before connecting electrical loads.

NOTICE Improper treatment of generator can damage it and shorten its life.

- Use generator only for intended uses.
- If you have questions about intended use, contact your authorized dealer.
- Operate generator only on level surfaces.
- Adequate, unobstructed flow of cooling and ventilating air is critical to correct generator operation.
- The Oil Fill, Oil Drain and the Control Panel doors must be installed whenever the unit is running.
- DO NOT expose generator to excessive moisture, dust, dirt, or corrosive vapors.
- Despite the safe design of the home generator, operating this equipment imprudently, neglecting its maintenance or being careless can cause possible injury or death.
- Remain alert at all times while working on this equipment. Never work on the equipment when you are physically or mentally fatigued.
- DO NOT start engine with air cleaner or air cleaner cover removed.
- DO NOT insert any objects through cooling slots.
- DO NOT use the generator or any of its parts as a step. Stepping on the unit can cause stress and break parts. This may result in dangerous operating conditions from leaking exhaust gases, fuel leakage, oil leakage, etc.
- If connected devices overheat, turn them off and disconnect them from generator.
- Shut off generator if:
 - electrical output is lost;
 - equipment sparks, smokes, or emits flames;
 - unit vibrates excessively.

Installation

We sincerely appreciate your patronage. For this reason, we have made every effort to provide for a safe, streamlined and cost-effective installation. Because each installation is unique, it is impossible to know of and advise the trade of all conceivable procedures and methods by which installation might be achieved. Neither could we know of possible hazards and/or the results of each method or procedure. For these reasons,

Only current licensed electrical and plumbing professionals should attempt home generator system installations. Installations must strictly comply with all applicable codes, industry standards and regulations.

Your home generator is supplied with this "Operator's Manual" and a separate "Installation Manual". These are important documents and should be retained by the owner after the installation has been completed.

For the Home Owner:

To help you make informed choices and communicate effectively with your installation contractor(s),

Read and understand *Owner Orientation* in this manual before contracting or starting your home generator installation.

To arrange for proper installation, contact the store at which you purchased your home generator, your dealer, a licensed electrician or your utility power provider.

The home generator warranty is VOID unless the system is installed by licensed electrical and plumbing professionals.

Every effort has been made to ensure that information in this manual is accurate and current. However, we reserve the right to change, alter, or otherwise improve the product and this document at any time without prior notice.

The Emission Control System for this generator is warranted for standards set by the U.S. Environmental Protection Agency and by the California Air Resources Board (CARB).

For the Installing Dealer/Contractor:

For most applications, the Installation manual contains all the information required to properly install and start the home generator. This operator's manual describes routine operation and owner maintenance procedures.

If you need more information in this matter, please call **(800) 743-4115**, between 8:00 AM and 5:00 PM CT.

Owner Orientation

This section provides home generator owners with the information necessary to achieve the most satisfactory and cost effective installation possible.

The illustrations are for typical circumstances and are meant to familiarize you with the installation options available with your home generator. A thorough understanding of these options will provide fundamental control over the cost of your installation, as well as ensure your final satisfaction and security.

Federal and local codes, appearance, noise levels, fuel types, and distances are the factors that must be considered when negotiating with an installation professional. Remember that as the distance from the existing electrical service and gaseous fuel supply increases, and the number of 90 degree bends in the fuel supply increases, compensations in piping and wiring materials must be made. This is necessary to comply with local codes and overcome electrical voltage drops and gaseous fuel pressure drops.

The factors mentioned above will have a direct affect on the overall price of your home generator installation.

In some areas you may need to acquire electrical permits for installing the home generator, building permits for installing gas lines, and permits for noise allowances. Your installer should check your local codes AND obtain the permits before installing the system.

Fuel Factors

An important consideration affecting the entire installation is the type of fuel used by your home generator. The system was factory tested and adjusted using either natural gas or liquid propane (LP vapor). For proper engine function, factors that are inherent to each of these fuels, your location and the duration of possible utility interruptions are important considerations in the following fuel guidelines:

- Use clean, dry fuel, free of moisture or any particulate material. Using fuels outside the following recommended values may cause performance problems.
- In engines set up to run on propane (LP), commercial grade HD5 propane with a minimum fuel energy of 2500 BTUs/ft³ with maximum propylene content of 5% and butane and heavier gas content of 2.5% and minimum propane content of 90%.

Natural gas rating will depend on specific fuel but typical derates are between 10 to 20% off the LP gas rating.

 **WARNING** Propane and Natural Gas are extremely flammable and explosive. Fire or explosion can cause severe burns or death.

- The home generator is equipped with an automatic safety gas “fuel shut-off” valve.
- DO NOT operate the equipment if the “fuel shut-off” valve is missing or inoperative.

Power Decrease at High Altitude or High Temperature

Air density is less at high altitudes, resulting in less available engine power. Specifically, engine power will decrease 3.5% for each 1,000 feet (300 meters) above sea level and 1% for each 10° F (5.6°C) above 77°F (25°C). Make sure you and your installer consider these factors when determining total generator load.

Generator Location

The actual physical location of your home generator has a direct affect on:

1. The amount of plumbing required to fuel your generator.
2. The amount of wiring required to control and connect your generator.

Specific location guidelines are discussed in the installation manual. Acquaint yourself with that information and confer with your installer. Be sure to ask how your site might affect installation costs and compliance with local codes and standards.

The generator must be installed outdoors. DO NOT install generator where exhaust gas could accumulate and enter inside or be drawn into a potentially occupied building. Ensure exhaust gas is kept away from any windows, doors, ventilation intakes or other openings that can allow exhaust gas to collect in a confined area. Prevailing winds and air currents should be taken into consideration when positioning generator. See the installation manual for full details on safe generator location.

 **WARNING** Running engine gives off carbon monoxide, an odorless, colorless, poison gas. Breathing carbon monoxide can cause headache, fatigue, dizziness, vomiting, confusion, seizures, nausea, fainting or death.

- Operate generator ONLY outdoors.
- Install a battery operated carbon monoxide alarm near the bedrooms.
- Keep exhaust gas from entering a confined area through windows, doors, ventilation intakes, or other openings.

 **WARNING** Exhaust heat/gases can ignite combustibles or structures causing a fire.

- DO NOT install the generator closer than 5 feet (1.5m) from any combustibles or structures with combustible walls having a fire resistance rating of less than 1 hour.

Delivery Inspection

Carefully inspect the home generator for any damage that may have occurred during shipment.

If loss or damage is noted at time of delivery, have the person(s) making delivery note all damage on the freight bill and affix his signature under the consignor's memo of loss or damage. If loss or damage is noted after delivery, separate the damaged materials and contact the carrier and your installer for claim procedures. Missing or damaged parts are not warranted.

The home generator is supplied with:

- Pre-attached mounting pad
- Fully-serviced oil/lubricating system
- Flexible fuel hook-up hose
- Installation and start-up manual
- Operator's manual
- Engine operator's manual
- Installation checklist
- Spare access door keys
- Spare 15A fuse
- Two pin connector
- Ten pin connector
- Touch up paint
- Remote LED indicator kit (LED/plate/screws)

To be supplied by Installer:

- Starting battery
- Connecting wire and conduit
- Fuel supply valves/plumbing
- Various specialty tools/equipment

Not for
Reproduction

Controls

Home Generator



Read this **Operator's Manual** and **Important Safety Instructions** before operating your generator.

Compare the illustrations with your generator to familiarize yourself with the locations of various controls and adjustments. **Save this manual for future reference.**

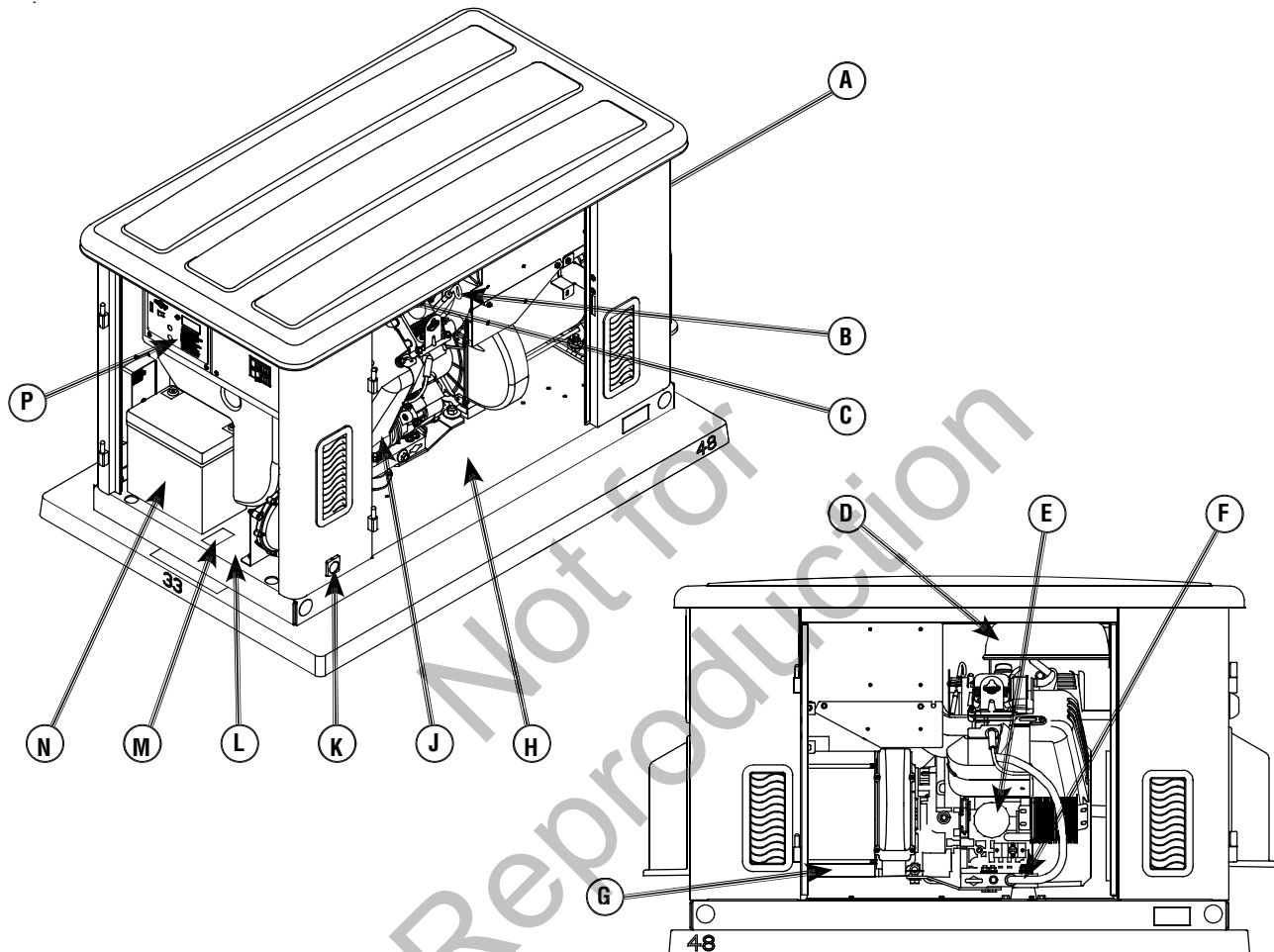

Generator is pictured with access doors removed for clarity

A - Exhaust Port — High-performance muffler lowers engine noise to comply with most residential codes.

B - Oil Dip Stick — Used to check the engine oil level.

C - Oil Fill Cap — Remove to service the engine with recommended oil.

D - Air Cleaner — Protects engine by filtering dust and debris out of intake air.

E - Oil Filter — Filters engine oil to prolong system life.

F - Oil Drain Hose — Provided to facilitate oil changing.

G - Oil Drain Door opening — Provides access for engine servicing.

H - Oil Fill Door opening — Provides access for engine servicing.

J - Engine Label — Identifies engine model and type.

K - Fuel Inlet — Fuel supply is connected here.

L - Control Panel Door opening — Provides access to control panel and battery.

M - Unit ID Label (located on base) — Identifies unit by serial number.

N - Battery — (installer-supplied) 12 Volt DC sealed battery provides power to start the engine.

P - Control Panel — Used for various test, operation and maintenance functions. See *System Control Panel*.

System Control Panel

Compare this control panel illustration with your generator to familiarize yourself with the location of these important controls:

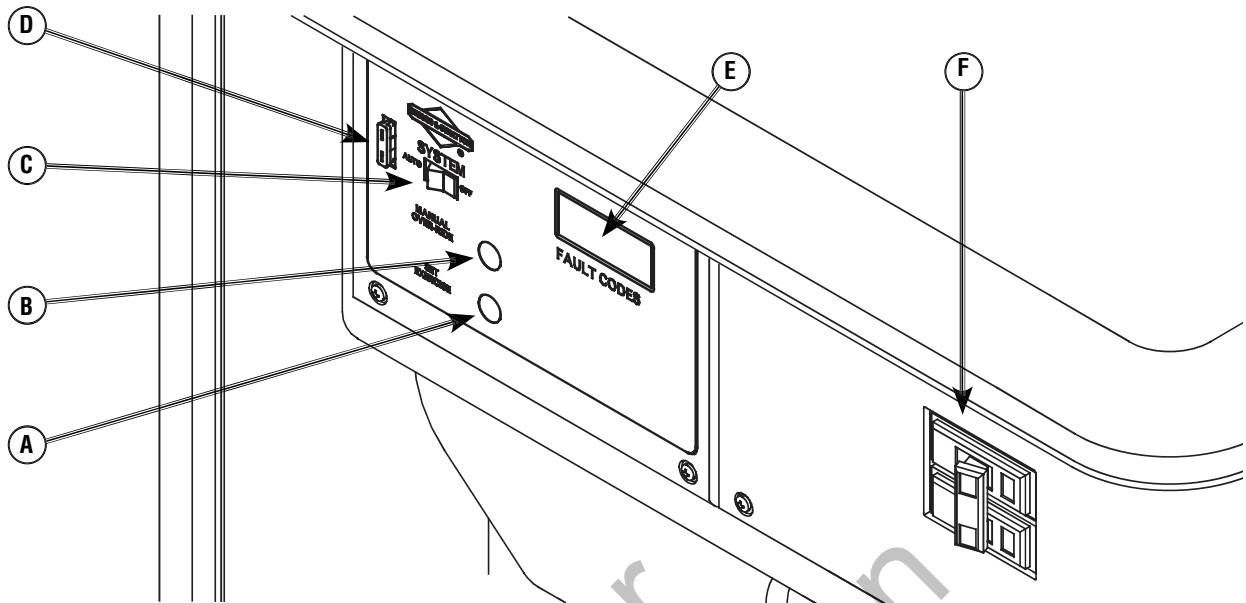

A - SET EXERCISE — Used to set the exercise cycle start time and day-of-the-week. Exercise cycle only occurs in **AUTO** mode.

B - MANUAL OVER-RIDE — With system switch in **AUTO** position, push the manual over-ride switch to start the generator. To turn off the generator, push and hold the manual over-ride switch again until engine stops.

C - System Switch — This two-position switch is the most important control on the system and is used as follows:

- “**AUTO**” position is the normal operating position. If a utility power outage is sensed, the system will start the generator. When utility power is restored, **AUTO** lets the engine stabilize internal temperatures, shuts off the generator, and waits for the next utility power outage.
- “**OFF**” position turns off running generator, prevents unit from starting and resets any detected faults.

D - 15 Amp Fuse — Protects the home generator DC control circuits. If the fuse has ‘blown’ (melted open) or was removed, the engine cannot crank or start. Replace the fuse using only an identical ATO 15A fuse.

E - Digital Display — Displays the total number of hours the generator has been running and fault codes. Used to schedule maintenance tasks and for troubleshooting operational problems with the residential generator. A constant number displayed indicates the total hours of operation. Fault conditions will flash “FC” followed by a fault code number. All fault conditions are described in *Fault Detection System*.

F - Circuit Breaker — Protects the system from shorts and other over-current conditions. Must be **ON** to supply power to the Automatic Transfer Switch.

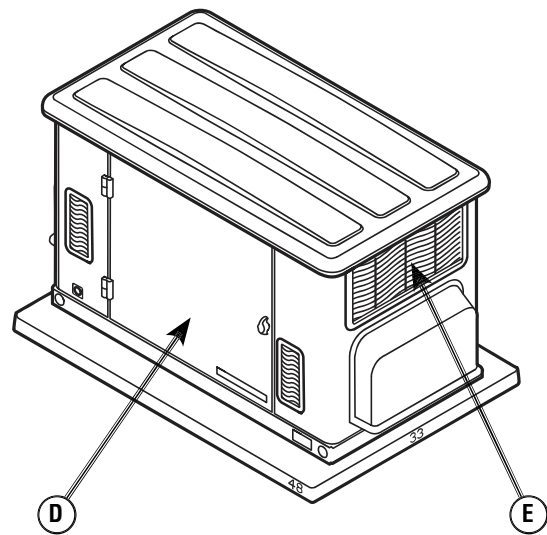
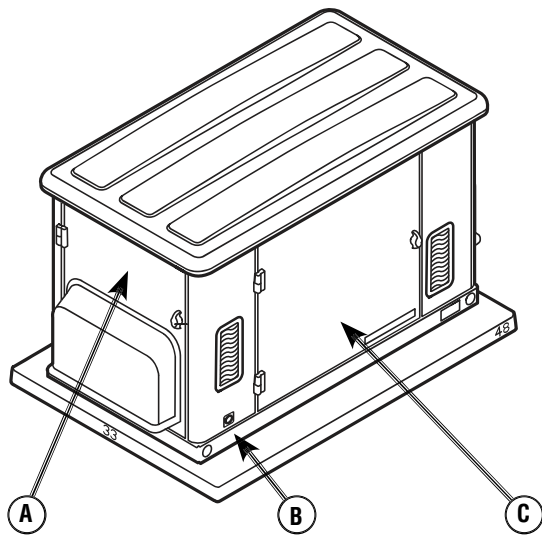

Access Ports

The home generator is equipped with an enclosure that has several access doors. The doors are named for a significant component located behind them, as follows:

- A Control Panel door
- B Fuel Inlet Port (shown for reference)
- C Oil Drain door
- D Oil Fill door
- E Exhaust Port (shown for reference)

▲ WARNING Contact with muffler and engine parts can result in serious burns.



- DO NOT touch hot parts and AVOID hot exhaust gases.
- Allow equipment to cool before touching.

The oil and control panel doors must be installed whenever the unit is running to assure proper cooling, reduce noise, and for added safety.

Each home generator is supplied with a set of identical keys. These keys fit the locks that secure the access doors.

To open access door:

1. Insert key into lock of access door handle and turn key one quarter turn counterclockwise.
2. Grasp door's handle and turn one quarter turn counterclockwise to open. Remove key.

To close access door:

1. Close door and turn door's handle one quarter turn clockwise.
2. Insert key into lock of door handle and turn key one quarter turn clockwise. Remove key.

Operation

Important Owner's Considerations

Engine Oil

NOTICE Any attempt to crank or start the engine before it has been properly serviced with the recommended oil will result in equipment failure.

- Refer to *Maintenance* in the Operator's Manual and engine manual for oil fill information.
- Damage to equipment resulting from failure to follow this instruction will void engine and generator warranty.

The engine is shipped from the factory pre-run and filled with synthetic oil (API SJ/CF 5W-30). This allows for system operation in a wide range of temperature and climate conditions. Before starting the engine, check oil level and ensure that engine is serviced as described in the engine operator's manual.

Battery

The installer must supply a valve-regulated, rechargeable 12 volt DC starting battery. See *Battery* in *Final Installation Considerations* in the installation manual. Installer must connect battery charge wire (wire #13) to positive battery terminal!

▲ WARNING Battery posts, terminals and related accessories contain lead and lead compounds, chemicals known to the State of California to cause cancer and reproductive harm. Wash hands after handling.

With the battery installed, all wiring to transfer switch and generator completed, utility power supplied to the automatic transfer switch, and the unit in **AUTO** mode, the battery receives a trickle charge while the engine is not running. The trickle charge cannot be used to recharge a battery that is completely discharged.

15 Amp Fuse

The generator's 15 Amp fuse is critical to correct system operation. The 15 Amp fuse was removed at the factory to prevent the unit from starting during shipping. Your installer will ensure the fuse is properly installed upon completion of the installation.

Automatic Operation

To select automatic operation, do the following:

1. Confirm 15 Amp fuse is installed in control panel.
2. Set the main distribution panel circuit breaker that sends utility voltage to the transfer switch to **ON**.
3. Set the generator's circuit breaker to its **ON** position.

 **CAUTION** With the system switch set to **AUTO**, the engine may crank and start at any time without warning.

- To prevent possible injury that may be caused by such sudden starts, always set the system switch to **OFF** if performing maintenance on the system.
- Remove the 15 Amp fuse before working on or around the generator or transfer switch.

4. Set the control panel system switch to **AUTO**.

Checking Automatic Operation

To check the system for proper automatic operation, proceed as follows:

1. Turn **OFF** the service disconnect or main distribution panel circuit breaker sending power to the automatic transfer switch.
When utility voltage is lost and the sensor has timed out, the engine will crank and start. Let the system go through its entire automatic operation sequence.
2. With the generator output supplying its loads, turn **ON** the service disconnect or main distribution panel circuit breaker that supplies utility power to the automatic transfer switch.
3. The automatic transfer switch will transfer loads back to utility power after a 5 minute minimum run time and utility power is available.
4. The generator will run for an additional one minute for engine cool down, then shut down.

If utility power is restored and generator does not shut down after 10 minutes, set system switch to **OFF** and contact your installer or local service center.

This completes the test procedures for automatic operation. The home generator will now start automatically and will supply power to the transfer switch when utility power is lost.

Setting Exercise Timer

The home generator is equipped with an exercise timer that will start and exercise the system once every seven days. During this exercise period, the unit runs for approximately 20 minutes and then shuts down. Electrical load transfer DOES NOT occur during the exercise cycle (unless an utility power outage occurs during the cycle).

A button on the control panel is labeled "SET EXERCISE" (see *System Control Panel*). The specific day and the specific time of day this button is pressed is programmed into the control board memory. This date and time is then used to automatically initiate the system exercise cycle. The "SET EXERCISE" legend on the control panel will flash until the set exercise cycle is set.

To perform the Set Exercise procedure:

1. Choose the day and time you want your home generator to exercise.
2. On that day and time, press and hold down "SET EXERCISE" for three seconds.
"SET EXERCISE" will flash until the button is pressed for three seconds, then "SET EXERCISE" will illuminate for 5 seconds, and finally turn off. The SET EXERCISE date and time are now 'locked-in' (registered in system memory).
3. Certain models will immediately start and run their 20 minute exercise cycle. Other models will initiate the 20 minute exercise cycle seven days after the SET EXERCISE date and time is 'locked-in'.

For example, if you press SET EXERCISE on Sunday morning at 10:00 AM, the unit is set to run an exercise cycle every Sunday at 10:00 AM (+/- 1/2 hour).

"Set Exercise" will only work if the unit is in the **AUTO** mode and this exact procedure is followed. The exerciser will need to be re-set if the 15 Amp fuse is removed or changed, or if the starting battery is disconnected.

If you want to change the day and time the unit exercises, simply perform the "Set Exercise" procedure at the exact weekday and time you want it to take place.

Maintenance

Servicing the System

Before performing any generator maintenance, always perform the following steps:

1. Set generator's circuit breaker to its **OFF** position.
2. Set control panel system switch to **OFF**.
3. Remove 15 Amp fuse from control panel.
4. **Utility voltage is present at generator control panel.**
Disconnect power before servicing control panel by removing the fuses from the transfer switch.
5. After all servicing has been completed, replace fuses in transfer switch, replace 15 Amp fuse in control panel, set system switch and circuit breaker ON and reset exercise timer. See *Setting Exercise Timer*.

Fault Detection System

The generator may have to run for long periods of time with no operator present. For that reason, the system is equipped with sensors that automatically shut down the generator in the event of potentially damaging conditions, such as low oil pressure, high temperature, over speed, and other conditions.

The generator's control panel has a digital display that shows fault codes, like "FC_1". The table below lists the detected fault, the fault code as displayed on the control panel, and the number of LED flashes (also described as 'blinks') seen on the remote LED indicator.

Fault Description	Fault Codes	LED Flashes
Low battery voltage	FC_1	1
Low oil pressure	FC_2	2
Low voltage	FC_3	3
Engine fails to start	FC_4	4
Low frequency	FC_5	5
Engine overspeed	FC_6	6
High temperature	FC_7	7
Transfer switch fault	FC_8	8

The remote LED indicator is installed at a convenient inside location. The LED will remain lit when the generator is in **AUTO**. Should a system fault be detected, the LED will turn on and off in a series of blinks that identify the problem. The blink pattern is repeated with a brief pause between each series of blinks.

Reset Fault Detection System

The operator must reset the fault detection system each time it activates. To do so, place the control panel system switch in the **OFF** position for 30 seconds or more. Remedy the fault condition, then return the home generator to service by placing the system switch in the **AUTO** position, installing the 15 Amp fuse, and resetting the exercise timer. See *Setting Exercise Timer in Operation*.

A description of each fault and suggested remedies are as follows:

No LED - Discharged Battery

If there is a detected fault condition but the LED is not blinking, this is because the battery is completely discharged. To remedy the problem, remove the 15 Amp fuse and disconnect the battery from the generator. Take the battery to a local battery store for analysis. Reinstall battery after it has been fully recharged, connecting the **NEGATIVE** cable last. Then reset the fault detection system, as described earlier.

Low Battery Voltage (FC_1)

This fault is indicated by fault code FC_1 and one blink on the LED indicator. This condition occurs if the generator cannot start because the starting battery output power is below that needed to crank the engine. Causes for this problem may be a faulty battery or battery charge circuit.

To remedy the problem, contact your local service center to check the battery charge output. Remove the 15 Amp fuse and disconnect the battery from the generator. Take the battery to a local battery store for analysis.

Reinstall the battery (replace if necessary - see *Battery* in *Final Installation Considerations* in the installation manual). Then reset the fault detection system, as described earlier.

Low Oil Pressure (FC_2)

This fault is indicated by fault code FC_2 and two blinks on the remote LED indicator. The unit is equipped with an oil pressure switch that uses normally closed contacts held open by engine oil pressure during operation. Should oil pressure drop below the 8 psi range, switch contacts close and the engine is shut down.

To remedy the low oil pressure condition, add the recommended oil to the FULL mark on the dipstick.

If the low oil pressure condition still exists, the engine will start, then shut down again. The fault code will appear and the LED will flash. In this case, contact an authorized dealer.

Low Voltage (Generator, FC_3)

This fault is indicated by fault code FC_3 and three blinks on the LED indicator. This condition is caused by a restriction in the fuel flow, a broken or disconnected signal lead, a failed alternator winding, the control panel circuit breaker is open, or the generator is overloaded.

To remedy the problem, contact your installer or an authorized dealer.

Engine Fail To Start (FC_4)

This fault is indicated by fault code FC_4 and four blinks on the LED indicator. This feature prevents the generator from damaging itself if it continually attempts to start in spite of another problem, such as no fuel supply. Each time the system is directed to start, the unit will crank for 10 seconds, pause for 10 seconds, and repeat. If the system does not begin producing electricity after approximately 2 minutes, the unit will stop cranking and the LED will blink.

Check to make sure the generator's circuit breaker is in the **ON** position in order for the sensing leads to verify that the unit is running.

The most likely cause of this problem is no fuel supply. Check the internal and external fuel shut off valves to ensure they are fully open. Other causes could be failed spark plug(s), failed engine ignition, or the engine air filter is clogged. You may need to contact your installer for assistance if you can't remedy these problems.

Low Frequency (FC_5)

This fault is indicated by fault code FC_5 and five blinks on the LED indicator. This feature protects devices connected to the transfer switch by shutting the generator down if the engine runs slower than 55 Hz for three seconds.

This condition is caused by a failed engine component or by excessive loads on the generator. To remedy the problem, contact your installer or an authorized dealer.

Engine Overspeed (FC_6)

This fault is indicated by fault code FC_6 and six blinks on the LED indicator. This feature protects devices connected to the transfer switch by shutting the generator down if the engine happens to run faster than the preset limit. The overspeed fault is detected as follows:

- If the generator output frequency is 65-70 Hz, after three seconds, the generator will shut down.
- If the generator output frequency is greater than 70 Hz, the generator will shut down immediately.

This condition is caused by a failed engine component. To remedy the problem, contact your installer or an authorized dealer.

High Temperature (FC_7)

This fault is indicated by fault code FC_7 and seven blinks on the LED indicator. The contacts of the temperature switch are normally open. If the engine temperature exceeds approximately 149°C (300°F), the fault is detected and the engine shuts down.

Common causes for this condition include running the unit with access doors removed, obstructed air inlet or exhaust port, low oil level, or debris in the engine cylinder cooling fins.

To resolve the problem, let the engine cool down and remove any accumulated debris and obstructions. Ensure that all access doors are installed whenever the unit is running.

Transfer Switch Fault (FC_8)

This fault is indicated by fault code FC_8 and eight blinks on the LED indicator (if transfer switch is equipped with fault detection).

The most likely cause of this fault is a blown fuse in the transfer switch. To remedy the problem, contact your installer or an authorized dealer.

Generator Maintenance

The generator warranty does not cover items that have been subjected to operator abuse or neglect. To receive full value from the warranty, the operator must maintain the system as instructed in the engine operator's manual.

All adjustments should be made at least once each season. Follow the requirements in the engine operator's manual.

Generator maintenance consists of keeping the unit clean. Operate the unit in an environment where it will not be exposed to excessive dust, dirt, moisture or any corrosive vapors. Cooling air louvers on the enclosure must not become clogged with snow, leaves, or any other foreign material. To prevent generator damage caused by overheating, keep the enclosure cooling inlets and outlets clean and unobstructed at all times.

Check the cleanliness of the unit frequently and clean when dust, dirt, oil, moisture or other foreign substances are visible on its exterior/interior surface. Inspect the air inlet and outlet openings inside and outside the enclosure to ensure air flow is not blocked.

DO NOT use direct spray from a garden hose to clean generator. Water can enter the engine and generator and cause problems.

Engine Oil

The engine is filled with synthetic oil (API SJ/CF 5W-30). This allows for system operation in the widest range of temperature and climate conditions.

The use of synthetic oil **does not** alter the required oil change intervals described in the engine operator's manual.

Changing Engine Oil

- ▲ CAUTION** Avoid prolonged or repeated skin contact with used motor oil.
- Used motor oil has been shown to cause skin cancer in certain laboratory animals.
 - Thoroughly wash exposed areas with soap and water.



KEEP OUT OF REACH OF CHILDREN. DON'T POLLUTE. CONSERVE RESOURCES. RETURN USED OIL TO COLLECTION CENTERS.

1. Set control board system switch to **OFF**.
2. Remove 15 Amp fuse from control panel.
3. Place oil drain hose into an approved container.
4. Remove brass fitting from end of drain hose.

Shown here is the oil drain hose (**B**) and the oil filter location (**A**):

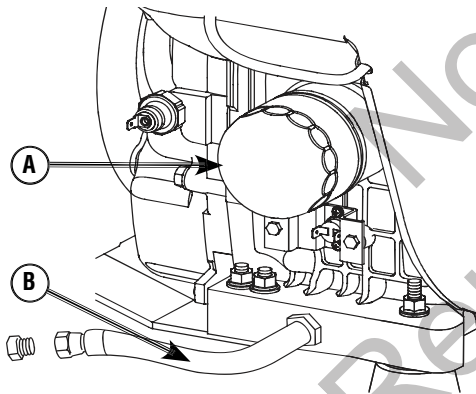

Change oil while the engine is still warm from running, as described in the engine operator's manual.

5. When oil has drained, replace brass fitting on hose.
6. Add oil. See next section.

To fill your engine with oil:

Follow the synthetic oil grade recommendation and oil fill instructions given in the engine operator's manual.

If all engine servicing is complete, replace 15 Amp fuse in control panel and reset exercise timer. See *Setting Exercise Timer in Operation*.

NOTICE Any attempt to crank or start the engine before it has been properly serviced with the recommended oil will result in equipment failure.

- Refer to *Maintenance* in the Operator's Manual and engine manual for oil fill information.
- Damage to equipment resulting from failure to follow this instruction will void engine and generator warranty.

Battery

Servicing of batteries is to be performed or supervised by personnel knowledgeable of batteries and the required precautions. Keep unauthorized personnel away from batteries.

Servicing the Battery

▲ WARNING Battery posts, terminals and related accessories contain lead and lead compounds, chemicals known to the State of California to cause cancer and reproductive harm. Wash hands after handling.

If it is necessary to service the battery, proceed as follows:

1. Set control board system switch to **OFF**.
2. Remove 15 Amp fuse from control panel.
3. Service or replace battery as required. See *Battery* in *Final Installation Considerations* in the installation manual for specific battery needed.
4. Connect red battery cable to battery positive terminal (indicated by **POSITIVE, POS, or (+)**).
5. Connect the battery charge wire (wire #13) shown as (**C**) below to the battery positive terminal (indicated by **POSITIVE, POS, or (+)**):

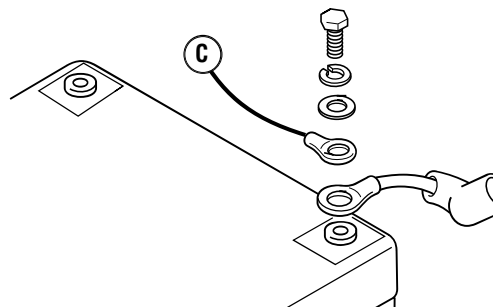

6. Connect black negative battery cable to negative battery terminal (indicated by **NEGATIVE, NEG, or (-)**).
7. Ensure hardware on both positive and negative battery terminals is secure.
8. Reinstall 15 Amp fuse in control panel.
9. Set generator's system switch to **AUTO**.
10. Reset exercise timer. See *Setting Exercise Timer*.



DON'T POLLUTE. CONSERVE RESOURCES, RETURN USED BATTERY TO RECYCLING COLLECTION CENTER.

Charging the Battery

If it is necessary to charge the battery, proceed as follows:

1. Set control board system switch to **OFF**.
2. Remove 15 Amp fuse from control panel.
3. Disconnect negative battery cable from negative battery terminal (indicated by **NEGATIVE, NEG,** or (-).

NOTICE Failure to disconnect negative battery cable will result in equipment failure.

- DO NOT attempt to jump start the generator.
 - Damage to equipment resulting from failure to follow this instruction will void engine and generator warranty.
4. Charge battery with battery charger at 2 Amps until battery holds 12 Volts. DO NOT exceed 13.7 volts when charging.

▲ WARNING Storage batteries give off explosive hydrogen gas during recharging. Slightest spark will ignite hydrogen and cause explosion. Battery electrolyte fluid contains acid and is extremely caustic.



Contact with battery contents will cause severe chemical burns.

A battery presents a risk of electrical shock and high short circuit current.

- DO NOT dispose of battery in a fire. Recycle battery.
- DO NOT allow any open flame, spark, heat, or lit cigarette during and for several minutes after charging a battery.
- DO NOT open or mutilate the battery.
- Wear protective goggles, rubber apron, rubber boots and rubber gloves.
- Remove watches, rings, or other metal objects.
- Use tools having insulated handles.

5. Connect negative battery cable to negative battery terminal (indicated by **NEGATIVE, NEG,** or (-)).
6. Ensure hardware on both positive and negative battery terminals is secure.
7. Reinstall 15 Amp fuse in control panel.

▲ CAUTION With the system switch set to **AUTO**, the engine may crank and start at any time without warning.



- To prevent possible injury that may be caused by such sudden starts, always set the system switch to **OFF** if performing maintenance on the system.
- Remove the 15 Amp fuse before working on or around the generator or transfer switch.

8. Set generator's system switch to **AUTO**.
9. Reset exercise timer. See *Setting Exercise Timer*.

Cleaning the Generator

1. Set control board system switch to **OFF**.
2. Remove 15 Amp fuse from control panel.
3. Clean generator as desired.

NOTICE Improper treatment of generator can damage it and shorten its life.

- DO NOT expose generator to excessive moisture, dust, dirt, or corrosive vapors.
 - DO NOT insert any objects through cooling slots.
 - Use a damp cloth to wipe exterior surfaces clean.
 - Use a soft, bristle brush to loosen caked on dirt, etc.
 - Use a vacuum cleaner to pick up loose dirt and debris.
 - Use low pressure air (not to exceed 25 psi) to blow away dirt. Inspect cooling air slots and openings on the generator. These openings must be kept clean and unobstructed.
4. Reinstall 15 Amp fuse in control panel.
 5. Set generator's system switch to **AUTO**.
 6. Reset exercise timer. See *Setting Exercise Timer*.

When Calling for Assistance

You must have the following information at hand if it is necessary to contact a local service center regarding service or repair of this unit:

1. Obtain the unit Model Number and Serial Number from the unit ID label. See *Controls* for location of the label or refer to the information recorded on the inside front cover of the installation manual.
2. Obtain the engine identification numbers from the engine label. See the engine operator's manual for location of this information. Please note that several different engines are described in the engine manual, so your engine may vary from that shown.

Storage

The home generator system is designed for long term service as a backup generator. There is no need to take any storage precautions. However, if it becomes necessary to take the system out of service for an extended period, call Technical Services at **(800) 743-4115**, between 8:00 AM and 5:00 PM CT for specific recommendations. Refer to the engine operator's manual for additional information.

Troubleshooting

Problem	Cause	Correction
Engine is running, but no AC output is available.	<ol style="list-style-type: none"> 1. Circuit breaker open or defective. 2. Fault in generator. 3. Poor wiring connections or defective transfer switch. 	<ol style="list-style-type: none"> 1. Reset or replace circuit breaker. 2. Contact local service facility. 3. Check and repair.
Engine runs good at no-load but “bogs down” when loads are connected.	<ol style="list-style-type: none"> 1. Short circuit in a connected load. 2. Generator is overloaded. 3. Shorted generator circuit. 4. Fuel Pressure is incorrect. 5. Natural gas fuel mixture is incorrect. 6. Kinked fuel line between regulator and engine. 	<ol style="list-style-type: none"> 1. Disconnect shorted electrical load. 2. Turn off one or more loads. 3. Contact local service facility. 4. See <i>Gaseous Fuel System</i> in the Installation Manual. 5. See <i>Gaseous Fuel System</i> in the Installation Manual. 6. Remove kink in fuel line. Replace if necessary.
Engine will not start; or starts and runs rough.	<ol style="list-style-type: none"> 1. 15 Amp fuse missing or blown. 2. Fuel supply turned off or depleted. 3. Failed battery. 	<ol style="list-style-type: none"> 1. Install (new) 15 Amp fuse. See <i>System Control Panel</i>. 2. Open fuel valve(s); check propane tank. 3. Replace battery.
Engine shuts down during operation.	<ol style="list-style-type: none"> 1. Fuel supply turned off or depleted. 2. Fault indicator blinking. 	<ol style="list-style-type: none"> 1. Check fuel valves, fill propane tank. 2. Count blinks and refer to <i>Fault Detection System</i>.
Loss of power on circuits.	<ol style="list-style-type: none"> 1. Generator circuit breaker is open. 2. Transfer switch problems. 	<ol style="list-style-type: none"> 1. Reset circuit breaker. 2. See the transfer switch manual.

Effective November 1, 2009 - replaces all undated Warranties and Warranties dated before November 1, 2009.

LIMITED WARRANTY

Briggs & Stratton Power Products Group, LLC will repair or replace, free of charge, any part(s) of the equipment that is defective in material or workmanship or both. Travel expenses are reimbursed as specified under the Briggs & Stratton Warranty Guidelines document to authorized Briggs & Stratton dealers for performing applicable warranty repair work. This warranty is effective for the time periods and subject to the conditions stated below. For all warranty service, find the nearest Authorized Service Dealer in our dealer locator map at BRIGGSandSTRATTON.COM.

THERE IS NO OTHER EXPRESS WARRANTY. IMPLIED WARRANTIES, INCLUDING THOSE OF MERCHANTABILITY AND FITNESS FOR A PARTICULAR PURPOSE, ARE LIMITED TO ONE YEAR FROM PURCHASE, OR TO THE EXTENT PERMITTED BY LAW. ANY AND ALL IMPLIED WARRANTIES ARE EXCLUDED. LIABILITY FOR INCIDENTAL OR CONSEQUENTIAL DAMAGES ARE EXCLUDED TO THE EXTENT EXCLUSION IS PERMITTED BY LAW. Some states or countries do not allow limitations on how long an implied warranty lasts, and some states or countries do not allow the exclusion or limitation of incidental or consequential damages, so the above limitation and exclusion may not apply to you. This warranty gives you specific legal rights and you may also have other rights which vary from state to state or country to country.

WARRANTY PERIOD

4 years or 1600 Hours, whichever comes first

The warranty period begins on the date of purchase by the first retail consumer and continues for the period of time stated above.

NO WARRANTY REGISTRATION IS NECESSARY TO OBTAIN WARRANTY ON BRIGGS & STRATTON PRODUCTS. SAVE YOUR PROOF OF PURCHASE RECEIPT. IF YOU DO NOT PROVIDE PROOF OF THE INITIAL PURCHASE DATE AT THE TIME WARRANTY SERVICE IS REQUESTED, THE MANUFACTURING DATE OF THE PRODUCT WILL BE USED TO DETERMINE THE WARRANTY PERIOD.

ABOUT YOUR WARRANTY

We welcome warranty repair and apologize to you for being inconvenienced. Any authorized service dealer may perform warranty repairs. Most warranty repairs are handled routinely, but sometimes requests for warranty service may not be appropriate. For example, warranty service would not apply if equipment damage occurred because of misuse, lack of routine maintenance, shipping, handling, warehousing or improper installation. Similarly, the warranty is void if the manufacturing date or the serial number on the equipment has been removed or the equipment has been altered or modified. During the warranty period, the authorized service dealer, at its option, will repair or replace any part that, upon examination, is found to be defective under normal use and service. This warranty will not cover the following repairs and equipment:

- **Normal Wear:** Outdoor Power Equipment and engines, like all mechanical devices, needs periodic parts and service to perform well. This warranty does not cover repair when normal use has exhausted the life of a part or the equipment.
- **Installation and Maintenance:** This warranty does not apply to equipment or parts that have been subjected to improper or unauthorized installation or alteration and modification, misuse, negligence, accident, overloading, overspeeding, improper maintenance, repair or storage so as, in our judgment, to adversely affect its performance and reliability. This warranty also does not cover normal maintenance such as adjustments, fuel system cleaning and obstruction (due to chemical, dirt, carbon, lime, and so forth).
- **Other Exclusions:** This warranty excludes starting battery, accessory parts, wear items such as oil gauges, o-rings, filters, fuses, or spark plugs, etc., or damage or malfunctions resulting from accidents, abuse, modifications, alterations, or improper servicing or freezing or chemical deterioration. This warranty excludes failures due to acts of God and other force majeure events beyond the manufacturers control. And this warranty excludes used, reconditioned, and demonstration equipment; equipment used for prime power in place of utility power, equipment used in mobile or rental applications, and equipment used in life support applications.

Enclosure is warranted against surface rust and corrosion for the first year of the warranty period.

Surface rust and corrosion is defined as any rust or corrosion that has penetrated the paint but has not penetrated through the metal substructure.

Enclosure is warranted against rust-through for the first two years of the warranty period.

Rust-through is defined as rust or corrosion that has penetrated completely through the paint and metal substructure.

Enclosure is not warranted for surface rust or corrosion or complete rust-through that may result due to improper installation, damage to painted surfaces that compromise the paint's corrosion prevention properties, or if the unit is installed in environments that expose the generator to high levels of corrosive agents. 207580E, Rev. B, 11/02/2009

BRIGGS & STRATTON POWER PRODUCTS GROUP, LLC
MILWAUKEE, WI, USA

Home Generator Systems

Product Specifications

Rated Maximum Load Current* (at 25°C/77°F, LP):
 at 240 Volts 83.3 Amps
Rated AC Voltage 240 Volts
Phase Single phase
Rated Frequency 60 Hertz
Normal Operating Range . -20°F (-28.8°C) to 104°F (40°C)
Output Sound Level .68 dB(A) at 23 ft. (7 m) at normal load
Shipping Weight 575 lb (260 kg)

* Natural gas rating will depend on specific fuel but typical derates are between 10 to 20% off the LP gas rating.

Not for
Reproduction

This generator is rated in accordance with UL (Underwriters Laboratories) 2200 (stationary engine generator assemblies) and CSA (Canadian Standards Association) standard C22.2 No. 100-04 (motors and generators).