

GPH13MED102 INSTALLATION AND OPERATION GUIDE

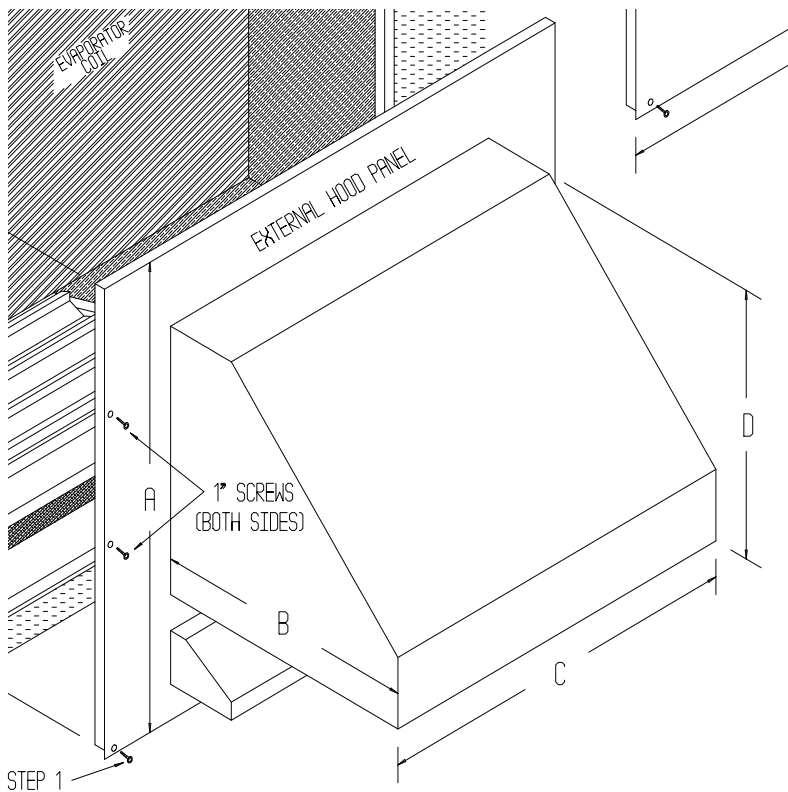

4. Outdoor air dampers open to minimum position and the compressor engages to provide mechanical cooling.
5. When the thermostat is satisfied the outside air dampers return to a closed position.

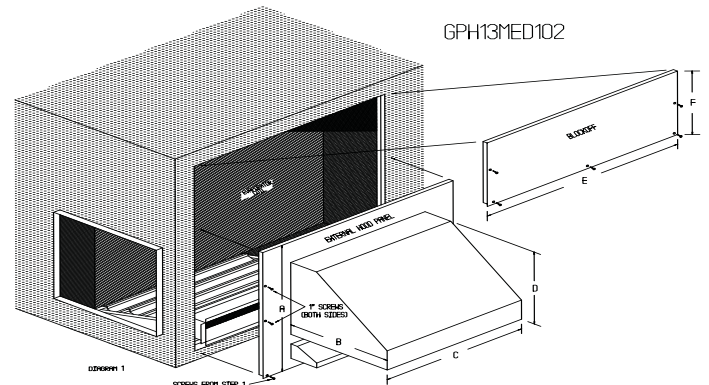

Figure 1

ECONOMIZER 101

Economizers are designed to provide “free” air conditioning when outside conditions are appropriate. When the outside air is cool and dry enough, the economizer automatically opens to introduce the cool air to the interior space, thereby eliminating the need to run the air conditioning compressor.

If the outside air becomes too warm or humid, the economizer automatically closes the fresh air damper and the compressor engages to begin cooling the space mechanically.

If a two stage thermostat is used it is possible to use a combination of economizer and mechanical cooling to condition the space.

The economizer can also be set to allow a minimum amount of fresh air to enter the space when the equipment’s indoor blower is operating.

Economizers are valuable tools to enhance indoor air quality, save energy and prolong the life of the air conditioning equipment.

SEQUENCE OF OPERATION

This sequence assumes employment of a single enthalpy economizer using a two stage thermostat.

1. A call for cooling comes from room thermostat.
2. The enthalpy sensor determines if the atmospheric conditions are conducive for using outside air for cooling. If YES, go to step 3. If NO, or if outdoor air temperature rises above enthalpy set point, go to step 4.
3. The outside air dampers open and modulate to maintain a mixed air temperature (outside air + indoor air) of 53 degrees F. If the outdoor air is insufficient to satisfy the thermostat alone and a second stage of cooling is required, the compressor starts and works in conjunction with the economizer

INSTALLATION

1. Open carton and inspect contents for shortages and damage.
2. Disconnect power to the package unit.
3. Remove large evaporator access panel from package unit.
4. Remove the horizontal duct opening cover.
5. Remove the downflow return air panel inside of the unit.
6. Install the internal damper rack over the downflow return air opening.
7. Attach the external hood/damper assembly to the side of the unit using screws removed in step 3.

NOTE: Ensure that the wires do not interfere with either the fresh air or return air damper operation. The wires should not be pinched between the fresh air hood and the unit or the return air dampers and the base pan.

8. Remove the molex plug from the wiring economizer wiring harness and feed the wires over to the packaged unit control panel.
9. Wire the economizer per the wiring diagram attached.
10. Connect the damper rod from the internal damper rack to the fresh air dampers.
11. Install the top block off panel/filter access with the screws provided.
12. Restore power to the unit.
13. Attach the horizontal duct opening cover.
14. Determine the proper enthalpy setting using enclosed control documentation if it is different from the factory ‘D’ setting.
15. Determine the minimum position setting using the minimum set point equation on page two.
16. Seal connection between the fresh air hood and unit until water tight.
17. Install Goodman IRKT-01 Isolation Relay Kit.

MINIMUM SET POINT EQUATION

$$(T_o \times OA) + (T_r \times RA) = T_m$$

To = Outdoor air temperature

OA= Percent of outdoor air

Tr = Return air temperature

RA= Percent of return air

Tm= Resulting mixed air temperature

Example:

Fresh air required is 10% outdoor air.

Outdoor air temperature is 60 degrees F.

Return air temperature is 75 degrees F.

$$(0.1 \times 60) + (0.9 \times 75) =$$

$$6.0 + 67.5 = 73.5$$

Mixed air temperature will be 73.5 degrees F when the OA is 60 degrees F and the RA is 75 degrees F with 10% outdoor air.

CONTENTS

1	Damper rack w/ economizer controls
1	Installation guide
1	Honeywell control literature
1	IRKT-01 Goodman Isolation Relay Kit

ACCESSORIES / CAPABILITIES

Dual Enthalpy - Requires an additional C7400 enthalpy control installed in the return air duct.

Demand Control Ventilation - Requires a CO2 sensor.

Remote Minimum Positioner - For applications requiring minimum position adjustments inside the conditioned space.

Important Notes

Failure to install the Goodman IRKT-01 Isolation Relay Kit will result in conflict between the economizer and unit during defrost mode.

Please see enclosed brochure for Honeywell component trouble shooting instructions.

Controller is factory set for power exhaust to engage when the dampers are 70% open.

A two stage thermostat is recommended with this accessory.

**GOODMAN HEAT PUMP WITH
W7214 / LS24-SR ECONOMIZER
PACKAGE**

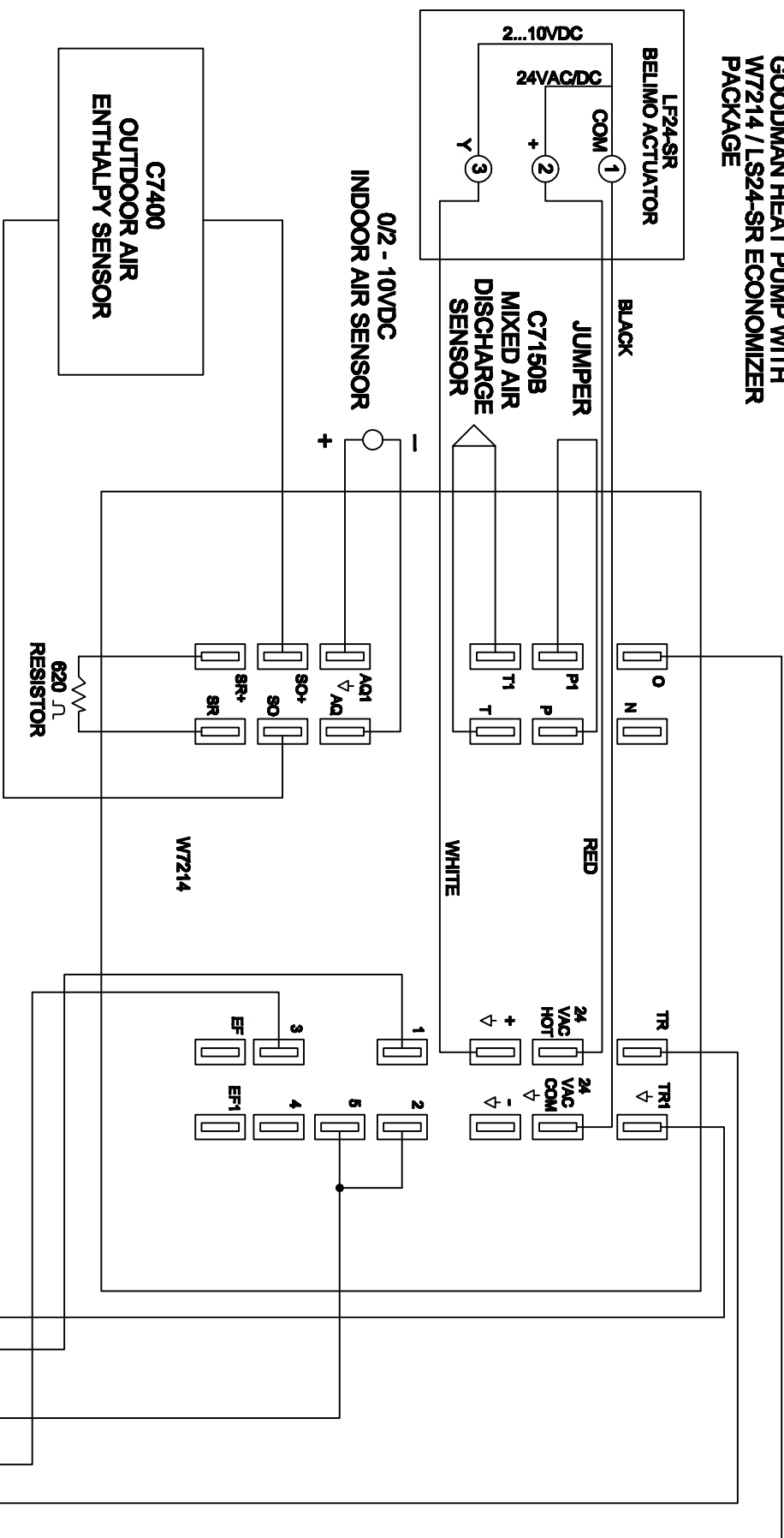

COLOR CODES

①	(P) PURPLE
②	(Y/R) YELLOW / RED
③	(G) GREEN
④	(BL) BLUE
⑤	(Y) YELLOW
⑥	(O) ORANGE

G	③	⑥	O
Y2 TSTAT	②	⑤	Y (CONTACTOR)
Y1 TSTAT	①	④	COMMON

