

BUDERUS

Conventional Gas Boilers



GC144 Series Residential Gas-Fired Boilers
GA124 Series Gas-Fired Sealed Combustion Boilers
G234X, G334X Series Gas-Fired Boilers

Quality. Versatility. Efficiency.
Superior Design.



Comfortable. Efficient. Intelligent Heating.

Buderus

Intelligent Heating—By Design



Buderus, the world leader in hydronic heating technology, manufactures the highest quality boilers based on 280 years of experience. With its innovative design and quality manufacturing, a Buderus boiler will outlast and out-perform virtually any other residential hot water system in the world.

The floor standing gas boilers are designed in Germany, where fuel costs are significantly higher and environmental regulations are more stringent. Established in 1731, Buderus uses state-of-the-art techniques in the design and manufacturing of its boilers.

Quality

Buderus patented GL-180M silicone injected, gray cast iron has excellent corrosion resistance against acidic combustion products, exceptional casting characteristics, and 40% greater flexibility and elasticity as well as high thermal conductivity to resist thermal shock under conditions of rapid temperature change. Quality and advanced engineering are also proven in the operation of the boilers.

The Buderus cast-iron sections are tightly joined together and sealed, ensuring a long life. Special compounds provide a gas-tight seal for safe and efficient operation. Staggered, contoured fins provide optimum heat transfer and efficiency, while the integrated draft inducer provides the added benefit of quiet operation.

All of this is packaged in an attractive design with front accessible controls. The GC144 models have side piping to making it an excellent choice for replacements. The GA124, the G234X and G334X feature rear piping for a clean, finished appearance any homeowner will appreciate.

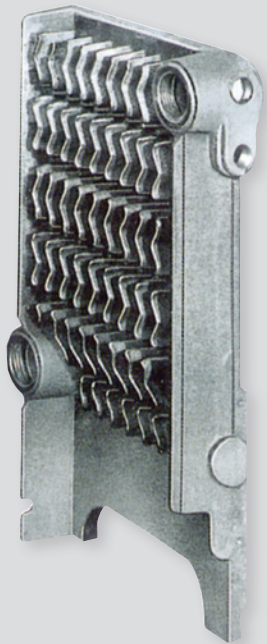

Special compounds provide a gas-tight seal for safe and efficient operation. And, thanks to the GL-180M cast iron's amazing flexibility, this boiler resists thermal shock under conditions of rapid temperature change.



Versatility

Need an atmospheric boiler that uses room air for the air intake, or a boiler that will vent through the side wall or a chimney? No problem—Buderus has a model for you.

The GA124 models allow for two venting configurations to best suit your demands. Choose from horizontal with concentric single wall penetration or vertical with a special “through the roof” system. The GA124 has been approved for use with Heat Fab, Z-Flex, Flex-L and Pro-Tech 3" AL 29-4C Steel materials.

Efficiency

These Buderus boilers are available for use with natural gas or can be easily converted to propane. Factory tested stainless steel premixed burners allow for low emissions, and superior thermal insulation virtually eliminates standby temperature losses. Buderus boilers are designed for a long life, providing efficiency, and durability for the homeowner, unsurpassed by the competition.

Stainless Steel Premixed Burners

- Low emissions with premixed burner technology
- Factory tested for natural gas operation
- All models easily convert to propane
- Complete burner tray is easily removed
- Durable, quiet, efficient and designed for long life

A Tradition of Excellence

In 1825 Buderus produced the world's first low-temperature hydronic heating systems. Today, Buderus products are acknowledged as the world standard in high-efficiency, low emissions hydronic heating. All Buderus products are designed to meet strict safety and environmental regulations. Our boilers are easy to install and are configured for easy access and service. Buderus boilers will typically outlast and outperform most any other hot water heating system, and with proper maintenance can continue to deliver the highest efficiency throughout their operating life.



Superior Design

- Whisper quiet operation with integrated draft inducer
- Clean combustion, extremely high efficiency, economical operation, and longevity
- Buderus boilers are the perfect central heating source for single or multiple family homes and help assure reliable heating for many years
- Attractive design with front accessible controls
- All sections are tightly joined and sealed; patented GL-180M silicone-injected, gray cast iron provides excellent resistance to corrosion and thermal shock

Boiler Control

The AquaSmart control is standard on all GC144, GA124 and G234X models. The HeatManager function adjust the boiler water temperature based on load for additional fuel savings.

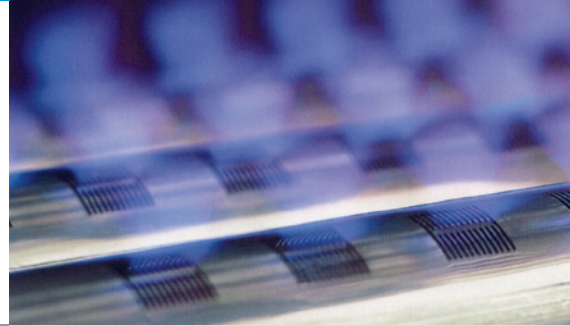

Flue passages of Buderus boilers have a gas tight seal thanks to a tongue and groove section design and elastic high temperature resistant sealing material. This seal is fully pressed into the groove during assembly.



Upgrade Your System for Added Comfort to Your Home!

Domestic Hot Water Tanks

In North America the average household spends around 30% of its energy costs on domestic hot water. Buderus designs its hot water tanks to work more economically and efficiently. Buderus pioneered new methods of producing and storing domestic hot water, so you are assured of greater operating efficiencies, lower fuel consumption and consistent hot water while saving money.

Buderus domestic hot water tanks offer features that provide for ease of installation, simple maintenance and reliable operation. All Thermoglaze models are equipped with a magnesium anode rod for protection against corrosion, a drain for easy maintenance, and have adjustable screw-on feet for leveling. An easy-access cover aids in cleaning and maintaining the coil and tank interior.

Buderus water tanks are a reliable and clean way to store hot water. From small residences to large commercial operations, there is a Buderus domestic hot water tank that is just right for your application.



Panel Radiators

Panel radiators provide a cleaner, quieter, and more comfortable source of heat. Buderus offers a broad range of high-quality radiators to satisfy your heating requirements. Conventional baseboard heat that provides only convective heat that warms the air. Panel radiators produce two types of heat: radiant and convected. Radiant heat, like the sun, warms objects rather than just the air, creating a greater sense of warmth faster and at lower room temperature.

Buderus' high performance hydronic steel panel radiators provide the perfect combination of both radiant and convective heat to create one of the most advanced and energy efficient heating systems available today. The design of Buderus radiators eliminates noise—no more clanking and hissing. Our radiators require less space than baseboard, enabling greater flexibility with furniture placement. And Buderus' unique styling offers space savings, design flexibility, and minimizes areas where dust and dirt can collect.



GC144 Series Replacement Boiler

Input: 74,000 to 132,500 BTU/Hr

The GC144 Series gas boiler requires very little space—but don't let its compact size fool you. This boiler has the quality and features you expect from Buderus. The precision castings are made using the patented Buderus GL180M cast iron, an extremely robust and durable material that can be shaped for perfect heat flow patterns. The stainless steel atmospheric premix gas burner ensures precise premixing for excellent energy utilization. All GC144 boilers are CSA approved for installation on combustible floors, have electronic ignition and can be installed in elevations up to 8500'. The slim profile and convenient side piping are designed for quick and easy installation—especially as a replacement boiler. All GC144 models feature the AquaSmart control with the HeatManager function to adjust the water temperature based on heating demand for additional fuel savings.



Features

- 85% AFUE efficiency
- Compact boiler with advanced low temperature technology
- Side piping design for convenient boiler retrofit installation
- Limited lifetime warranty[§]
- 3 Models with inputs from 74,000 to 132,500 BTU/Hr

[§] See www.buderus.us for complete warranty details

GL180M silicone injected flexible cast iron



Stainless steel pre-mixed burner tubes



Better insulation



Standard chimney vent



Easy wiring

GC144 Dimensions and Connections

Rear, side, and front view measurements in inches.

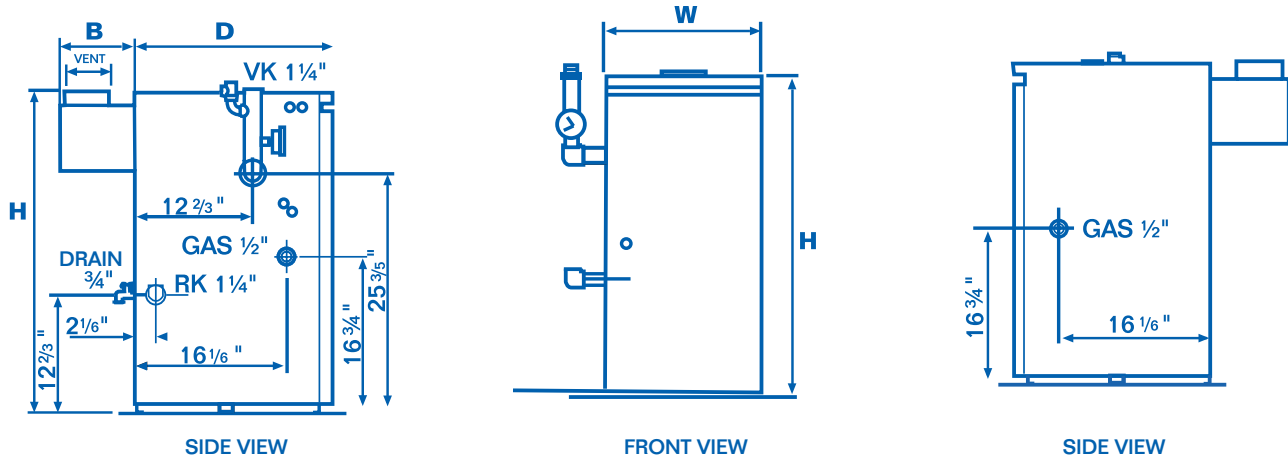

Electronic Ignition with Vent Damper for Conventional Chimney Venting.*

Model	GC144/3	GC144/4	GC144/5
Input BTU/Hr	74,000	103,000	132,500
D.O.E Capacity BTU/Hr	62,000	87,000	112,000
AFUE%	85		
Dimensions, in (HxDxW)	34 ³ / ₈ x 13 ¹ / ₈ x 21 ¹ / ₂	34 ³ / ₈ x 16 ³ / ₄ x 21 ¹ / ₂	34 ³ / ₈ x 20 ³ / ₈ x 21 ¹ / ₂
Piping Connections Supply, in	1 ¹ / ₄ NPT		
Piping Connections Return, in	1 ¹ / ₄ NPT		
FLUE, in (Vent: B)	5 : 8	5 : 8 ² / ₅	6 : 9 ¹ / ₂
Weight, lbs	228	287	349.5

*GC144 models are not suitable for use with Logamatic Controls.

Figure 1

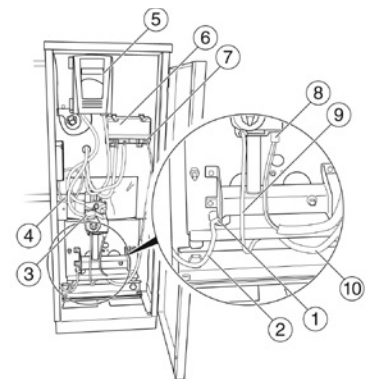

- 1: Flame roll-out switch
- 2: Flame roll-out switch cable
- 3: Gas valve
- 4: Gas supply pipe
- 5: Boiler temperature controller
- 6: Ignition module
- 7: Igniter cable
- 8: Gas valve cable connector
- 9: Pilot line
- 10: Igniter cable



CRN No 1597.9C
MA Plumbing Board Approved

GA124 Series Sealed Combustion Gas Boilers

Input: 70,000 to 123,000 BTU/Hr

GA124 Series Gas Fired Sealed Combustion and Draft Induced Boilers set new standards for quality and comfort. If you have a cramped mechanical room with limited combustion air—no problem! The GA124 Series Sealed Combustion Gas Boiler features low temperature operation and special GL-180M cast iron, low emissions with premixed burner technology, and a reduced footprint for tight spaces. Suitable for installation on combustible flooring. Standard equipment includes stainless steel burners, factory assembled and wired boiler, all feature the AquaSmart control with the HeatManager function to adjust water temperature based on heating demand for additional fuel savings, slow opening gas valve, and 3" insulated jacket. Concentric termination body is included for horizontal sealed combustion or direct vent application. Boilers are set for natural gas at sea level.



Features

- AFUEs above 85%
- Durable, quiet, efficient and designed for long life
- Streamlined control system
- Sealed combustion and draft
- Limited lifetime warranty[§]

[§] See www.buderus.us for complete warranty details

GA124 Dimensions and Connections

Rear, side, and front view measurements in inches.

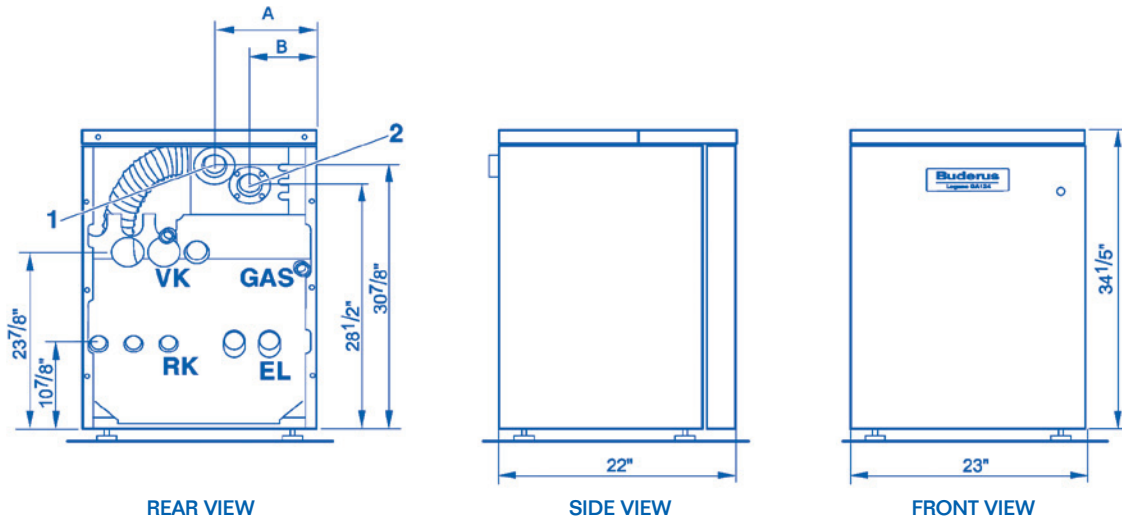

Model	GA124/17	GA124/23	GA124/30
Performance Data			
Input BTU/Hr	70,000	94,000	123,000
D.O.E Capacity BTU/Hr	59,000	79,000	104,000
Net IBR BTU/Hr	51,000	69,000	90,000
AFUE %	85.2	85.1	85
Piping Connections			
Pressure Drop @ 20° F Δ T (In WC)	18.1	22.9	32.2
Vent Connection Size, in		3	
Gas Connection, in		1/2	
Air Intake Connection, in		3	
Boiler Supply & Return, in		1	
Physical Dimensions			
Ignition Type		Intermittent	
Number of Burners	2	3	4
Overall Boiler Length, in		22	
Boiler Width, in		23	
Height, in		34 1/4	
Dimension A, in	7 1/4	8	9 1/4
Dimension B, in	3 1/8	6 3/4	10 1/4
Dry Weight (lbs.)	229	240	337

Figure 1

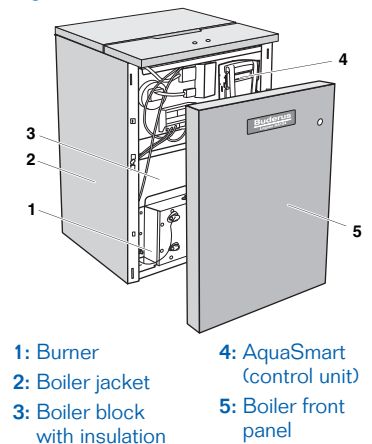

Venting Requirements

Intake: Use 3" galvanized pipe or flexible pipe.

Exhaust: Use only flue pipes and accessories with a 3" diameter. Manufacturer installation and assembly instructions must be followed.

Use rigid or flexible metallic pipes with a diameter of 3" for the combustion line. The flue system components can be ordered as accessories from your wholesaler or from other suppliers of accessories.



MEA 117-02-E
CRN No 1597.9C
MA Plumbing Board Approved

G234X | G334X Atmospheric Gas Boilers

Input: 160,000 to 541,000 BTU/Hr

Buderus boilers are manufactured to the highest standards. The boilers are designed with premixed burner technology for low emissions, a factory tested gas operation, and may be field-converted to propane. To aid in cleaning and servicing the burner tray is completely removable. All Buderus boilers are durable, quiet, efficient and designed for long life.



Features

- Full line of atmospheric gas boilers
- Flexible, corrosion resistant GL-180M cast iron heat exchangers
- Electronic ignition, three-inch thermal insulation
- 160,000 to 541,000 BTU/Hr Input



G234X | G334X Dimensions and Connections

Rear, side, and front view measurements in inches.

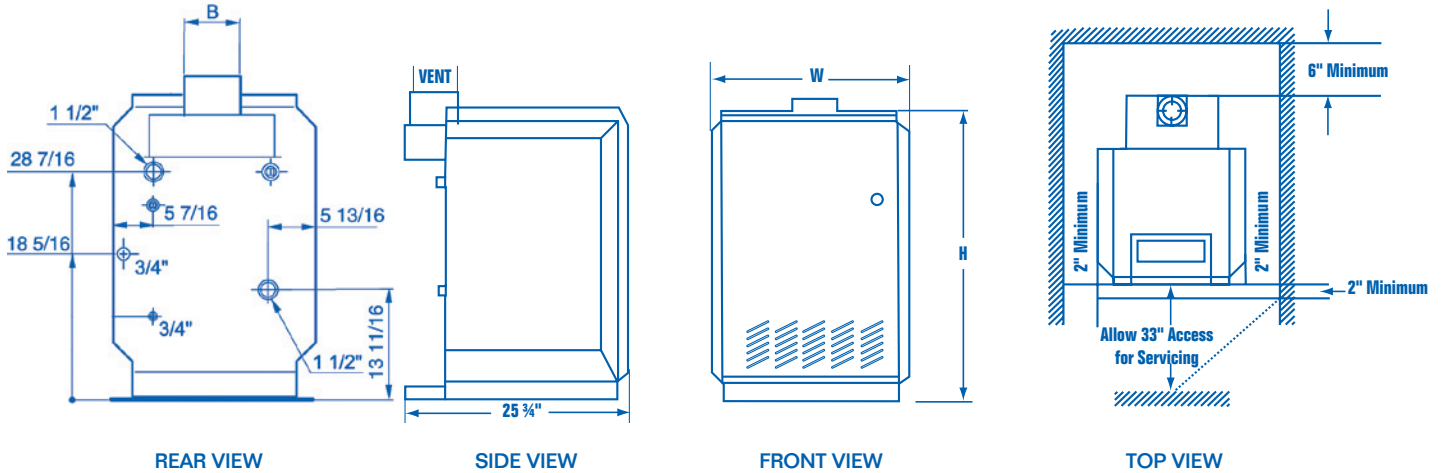

Model	G234X/38	G234X/45	G234X/55	G234X/64	G334X/73	G334X/92	G334X/116	G334X/132
Performance Data								
Input BTU/Hr	160,000	187,000	228,000	266,000	301,000	378,000	476,000	541,000
D.O.E Capacity BTU/Hr	130,000	154,000	188,000	219,000	249,000	314,000	396,000	450,000
Net IBR BTU/Hr	113,000	134,000	163,000	190,000	217,000	273,000	344,000	392,000
AFUE %	84.0				-	-	-	-
Combustion Efficiency	-	-	-	-	82.7	83.1	83.2	
Thermal Efficiency	-	-	-	-	81.2	81.6	81.7	
Piping Connections								
Damper Included?	Yes				Optional			
Gas Connection, in	3/4				1 1/4			
Physical Dimensions								
Boiler Width, in (W)	25 9/16		29 1/8	32 3/4	34 3/4	41 3/4	48 3/4	56
Height, in (H)	38 1/2				40 2/3			
Dry Weight, lbs	487		562	684	758	930	1,093	1,265
Water Content, gal.	6.1		7.1	8.2	9.2	11.4	13.5	15.6
Vent, in	7			8	8	9	10	

Figure 1: G234X

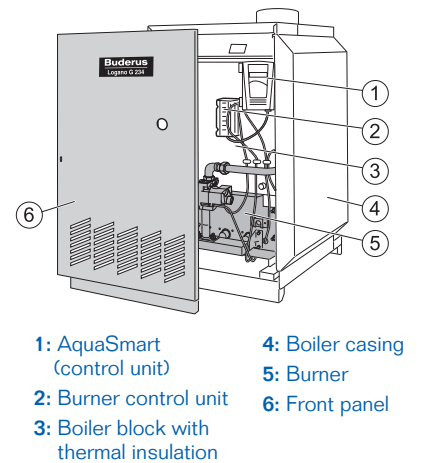

MEA 217-98-E
CRN No. 7169.7C
MA Plumbing Board Approved



The World's leader in heating technologies since 1825, Buderus produced the world's first low temperature hydronic heating systems. In 2008 Buderus became a member of the Bosch Group, representing the Bosch, Buderus and FHP brands with products that are designed to improve efficiency, reliability and are environmentally friendly. Bosch Thermotechnology offers floor-standing and wall mounted boilers, domestic hot water tanks, solar thermal systems, geothermal heat pumps, and tankless water heaters.



755995008A 3/2014
Copyright © 2014 Bosch Thermotechnology Corp.
All rights reserved. Subject to change without notice.