

Homelite®

OPERATOR'S MANUAL PORTABLE GENERATOR SET 6,000 WATT HG6000

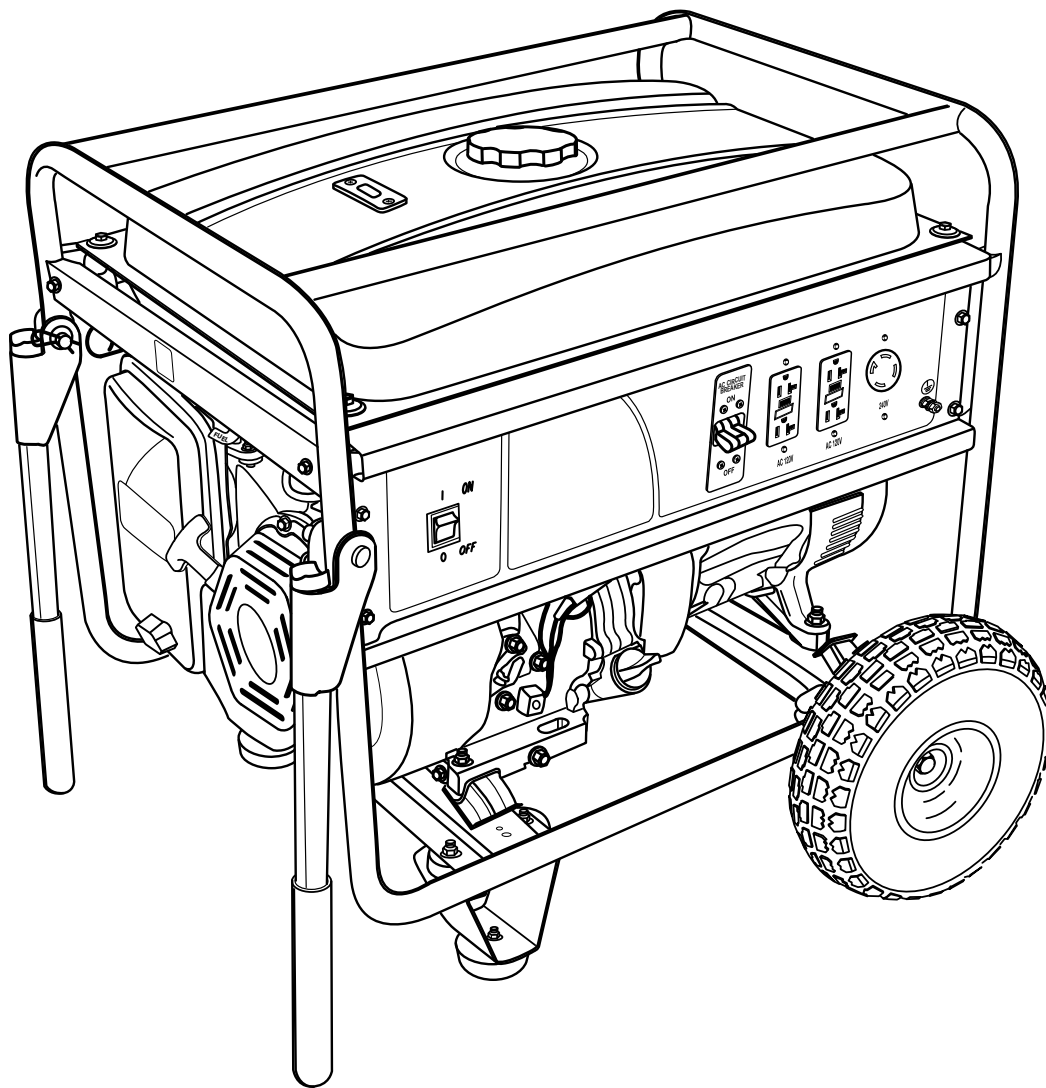

Your new generator has been engineered and manufactured to a high standard for dependability, ease of operation, and operator safety. When properly cared for, it will give you years of rugged, trouble-free performance.



DANGER: You WILL be KILLED or SERIOUSLY HURT if you do not follow the instructions in this operator's manual.

Thank you for your purchase.

SAVE THIS MANUAL FOR FUTURE REFERENCE

TABLE OF CONTENTS

■ Introduction.....	2
■ General Safety Rules	3
■ Specific Safety Rules.....	4
■ Symbols	5-7
■ Electrical	8-9
■ Features	10-11
■ Loose Parts List	12
■ Assembly	13-14
■ Operation	14-16
■ Maintenance	17-20
■ Troubleshooting	21
■ Wiring Diagram	22
■ Warranty.....	23
■ Parts Ordering / Service	Back Page

INTRODUCTION

This product has many features for making its use more pleasant and enjoyable. Safety, performance, and dependability have been given top priority in the design of this product, making it easy to maintain and operate.

DANGER

GROUNDING THE GENERATOR

To avoid the risk of shock or electrocution, generator must be properly grounded. The nut and ground terminal on the frame must always be used to connect the generator to a suitable ground source. The ground path should be made with #8 size wire. Connect the terminal of the ground wire between the lock washer and the nut, and tighten the nut fully. Connect the other end of the wire securely to a suitable ground source.

The National Electric Code contains several practical ways in which to establish a good ground source. If a steel or iron rod is used, it should be at least 5/8 in. diameter, and if a nonferrous rod is used, it should be at least 1/2 in. diameter and be listed as material for grounding. Drive the rod or pipe to a depth of 8 ft. If a rock bottom is encountered less than 4 ft. down, bury the rod or pipe in a trench.

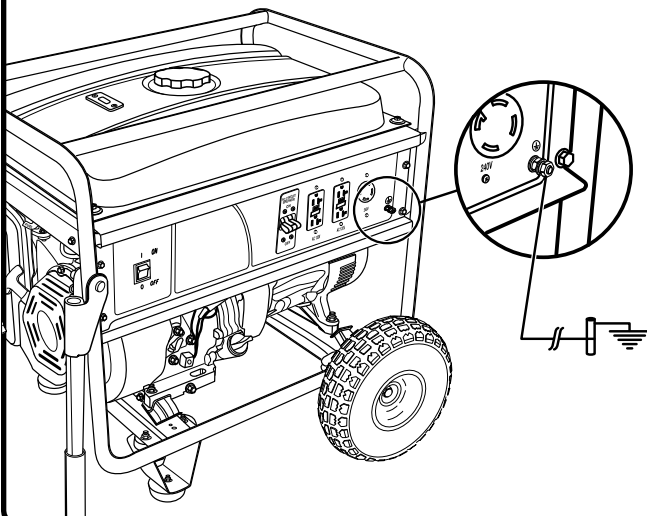

All electrical tools and appliances operated from this generator must be properly grounded by use of a third wire or be "Double Insulated."

It is recommended to:

1. Use electrical devices with 3-prong grounded plugs.
2. Use an extension cord with a 3-pole receptacle and a 3-prong plug at opposite ends to ensure continuity of the ground protection from the generator to the appliance.

Check and adhere to all applicable federal, state, and local regulations relating to grounding specifications. Consult a qualified electrician or service personnel if the grounding instructions are not completely understood or if in doubt as to whether the generator is properly grounded.

GENERAL SAFETY RULES



WARNING:

Read and understand all instructions. Failure to follow all instructions listed below may result in electrocution, fire, and/or carbon monoxide poisoning, which will cause death or serious injury.











- Do not allow children or untrained individuals to use this unit.
- Never start or run the engine inside a closed or partially enclosed area. Breathing exhaust fumes will kill you.
- Wear eye protection which is marked to comply with ANSI Z87.1 as well as hearing protection when operating this equipment.
- Keep all bystanders, children, and pets at least 10 feet away.
- Wear sturdy and dry shoes or boots. Do not operate while barefoot.
- Do not operate generator when you are tired or under the influence of drugs, alcohol, or medication.
- Keep all parts of your body away from any moving parts and all hot surfaces of the unit.
- Product users on United States Forest Service land, and in some states, must comply with fire prevention regulations. This product is not equipped with a spark arrestor. Check with the federal, state, or local authorities in your area before use.
- Do not touch bare wire or receptacles.
- Do not use generator with electrical cords which are worn, frayed, bare, or otherwise damaged.
- Before storing, allow the engine to cool.
- Do not operate generator in rain, snow, or wet weather.
- Empty fuel tank, close fuel valve, and restrain the unit from moving before transporting in a vehicle.
- Allow engine to cool for five minutes before refueling.
- To reduce the risk of fire and burn injury, handle fuel with care. It is highly flammable.
- Do not smoke while handling fuel.
- Store fuel in a container approved for gasoline.
- Position the unit on level ground, stop engine, and allow to cool before refueling.
- Loosen fuel cap slowly to release pressure and to keep fuel from escaping around the cap.
- Tighten the fuel cap securely after refueling.
- Wipe spilled fuel from the unit.
- Never attempt to burn off spilled fuel under any circumstances.
- Use only authorized replacement parts and accessories and follow instructions in the Maintenance section of this manual. Use of unauthorized parts or failure to follow Maintenance instructions may create a risk of shock or injury.
- Maintain the unit per maintenance instructions in this Operator's Manual.
- Inspect the unit before each use for loose fasteners, fuel leaks, etc. Replace damaged parts.
- National Electric Code requires generator to be grounded to an approved earth ground. Before using the ground terminal, consult a qualified electrician, electrical inspector, or local agency having jurisdiction for local codes or ordinances that apply to the intended use of the generator.

SPECIFIC SAFETY RULES

- Exhaust contains poisonous carbon monoxide, a colorless, odorless gas. Breathing exhaust can cause loss of consciousness and can lead to death. If running in a confined or partially-enclosed area, the air may contain a dangerous amount of carbon monoxide. To keep exhaust fumes from building up, always provide adequate ventilation.
- Always use a battery-powered carbon monoxide detector when running the generator. If you begin to feel sick, dizzy, or weak while using the generator, shut it off and get to fresh air immediately. See a doctor. You may have carbon monoxide poisoning.
- Place the generator on a flat, stable surface with a slope of no more than 4°.
- Operate in a well-ventilated, well-lit area isolated from working areas to avoid noise interference.
- Operating the generator in wet conditions could result in electrocution. Keep the unit dry.
- Keep the generator a minimum of 3 feet away from all types of combustible material.
- Do not operate generator near hazardous material.
- Do not operate generator at a gas or natural gas filling station.
- Do not touch the muffler or cylinder during or immediately after use; they are HOT and will cause burn injury.
- Do not connect to a building's electrical system unless a transfer switch has been properly installed by a qualified electrician.
- To connect a generator to your existing wiring, notify your utility company that you are installing a generator for backup power. Then have a licensed electrical contractor install a transfer switch. The transfer switch isolates your home from the ability to "back feed" neutral power lines. Failure to isolate the generator from power utility can result in death or injury to electric utility workers.
- Do not allow the generator's gas tank to overflow when filling. Fill to 1 in. below the top neck of the gasoline tank to allow for fuel expansion. Check the ventilation hole inside the fuel tank cap for debris. Do not block the vent.
- Do not smoke when filling the generator with gasoline.
- Allow the engine to remain in a shut-down condition for at least five minutes before adding gasoline or oil.
- Do not remove the oil dipstick or the fuel tank cap when the engine is running.
- Pay close attention to all safety labels located on the generator.
- Keep children a minimum of 10 feet away from the generator at all times.
- The unit operates best in temperatures between 23°F and 104°F with a relative humidity of 90% or less.
- Specific modifications for high-altitude performance are needed if the generator will **always** be operated at altitudes above 5,000 feet. Contact your nearest Baja authorized service center for more information and to have these modifications performed.
- Save these instructions. Refer to them frequently and use them to instruct others who may use this tool. If you loan someone this tool, loan them these instructions also.



SYMBOLS

Some of the following symbols may be used on this product. Please study them and learn their meaning. Proper interpretation of these symbols will allow you to operate the product better and safer.

SYMBOL	NAME	DESIGNATION/EXPLANATION
V	Volts	Voltage
A	Amperes	Current
Hz	Hertz	Frequency (cycles per second)
W	Watt	Power
hrs	Hours	Time
gal	Gallon	Volume
qt	Quart	Volume
	Wet Conditions Alert	Do not expose to rain or use in damp locations.
	Read The Operator's Manual	To reduce the risk of injury, user must read and understand operator's manual before using this product.
	Eye Protection	Always wear safety goggles or safety glasses with side shields and, as necessary, a full face shield when operating this product.
	Safety Alert	Precautions that involve your safety.
	Electric Shock	Failure to use in dry conditions and to observe safe practices can result in electric shock.
	Toxic Fumes	Running generator gives off carbon monoxide, an odorless, colorless, poison gas. Breathing carbon monoxide can cause nausea, fainting, or death.
	Fire/Explosion	Fuel and its vapors are extremely flammable and explosive. Fire or explosion can cause severe burns or death.
	Hot Surface	To reduce the risk of injury or damage, avoid contact with any hot surface.
	Lifting Hazard	To reduce the risk of serious injury, avoid attempting to lift the generator alone.
	Ground	Consult with local electrician to determine grounding requirements before operation.
	Electrocution	Failure to properly ground generator can result in electrocution, especially if the generator is equipped with a wheel kit.

SYMBOLS

The following signal words and meanings are intended to explain the levels of risk associated with this product.

SYMBOL	SIGNAL	MEANING
	DANGER:	Indicates an imminently hazardous situation, which, if not avoided, will result in death or serious injury.
	WARNING:	Indicates a potentially hazardous situation, which, if not avoided, could result in death or serious injury.
	CAUTION:	Indicates a potentially hazardous situation, which, if not avoided, may result in minor or moderate injury.
	CAUTION:	(Without Safety Alert Symbol) Indicates a situation that may result in property damage.

SERVICE

Servicing requires extreme care and knowledge and should be performed only by a qualified service technician. For service, contact Baja Motorsports at 1-866-260-8280. When servicing, use only identical replacement parts.

 **DANGER:**
To avoid death or serious personal injury, do not attempt to operate this product until you read thoroughly and understand completely the operator's manual. If you do not understand the warnings and instructions in the operator's manual, do not use this product. Call Baja customer service for assistance.

 **WARNING:**
Observe all normal safety precautions related to avoid electrical shock.

 **WARNING:**

 The operation of any products can result in foreign objects being thrown into your eyes, which can result in severe eye damage. Before beginning power tool operation, always wear safety goggles or safety glasses with side shields and, when needed, a full face shield. We recommend Wide Vision Safety Mask for use over eyeglasses or standard safety glasses with side shields. Always wear eye protection which is marked to comply with ANSI Z87.1.

SAVE THESE INSTRUCTIONS

SYMBOLS

SAFETY LABELS

The information below can be found on the generator. For your safety, please study and understand all of the labels before starting the generator.

If any of the labels come off the unit or become hard to read, contact a Baja authorized service center for replacement.

FUEL WARNING

No smoking when filling with gasoline. Do not overfill. Full level is 1 in. below the top of the fuel neck. Stop the engine for five minutes before refueling to avoid the heat from the muffler igniting fuel vapors.

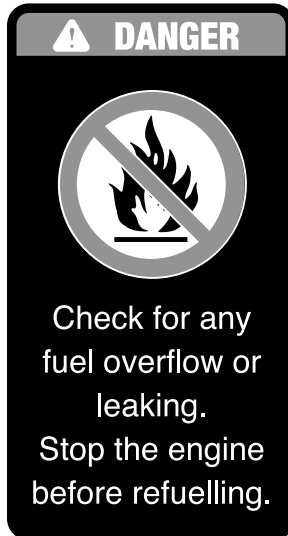

ENGINE OIL WARNING

You must add oil before first operating the generator. The oil reservoir capacity is 1.2 qt. Always check the oil level before each operation. The oil level should always register within the hatched area on the dipstick. The unit is equipped with an oil sensor which will automatically shut off the engine if oil level falls below a safe limit.



HOT SURFACE WARNING

Do not touch the muffler or aluminum cylinder of the engine. They are very HOT and will cause severe burns. Don't put any flammable or combustible materials in the direct path of the exhaust.



GROUNDING WARNING

National Electric Code requires generator to be grounded to an approved earth ground.

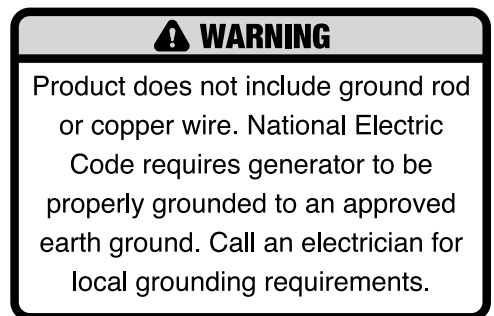

VENTILATION WARNING

Do not use the generator in an enclosed area or near open windows, vents, or doors. Fumes from the unit can kill.



ELECTRICAL

EXTENSION CORD CABLE SIZE

Refer to the table below to ensure the cable size of the extension cords you use are capable of carrying the required load. Inadequate size cables can cause a voltage drop, which can burn out the appliance and overheat the cord.

Current in Amperes	Load in Watts		Maximum Allowable Cord Length				
	At 120V	At 240V	#8 Wire	#10 Wire	#12 Wire	#14 Wire	#16 Wire
2.5	300	600		1000 ft.	600 ft.	375 ft.	250 ft.
5	600	1200		500 ft.	300 ft.	200 ft.	125 ft.
7.5	900	1800		350 ft.	200 ft.	125 ft.	100 ft.
10	1200	2400		250 ft.	150 ft.	100 ft.	50 ft.
15	1800	3600		150 ft.	100 ft.	65 ft.	
20	2400	4800	175 ft.	125 ft.	75 ft.		
25	3000	6000	150 ft.	100 ft.			
30	3600	7200	125 ft.	65 ft.			
40	4800	9600	90 ft.				

ELECTRIC MOTOR LOADS

It is characteristic of common electric motors in normal operation to draw up to six times their running current while starting. This table may be used to estimate the watts required to start "Code G" electric motors; however, if an electric motor fails to start or reach running speed, turn off the appliance or tool immediately to avoid equipment damage. Always check the requirements of the tool or appliance being used compared to the rated output of the generator.

Motor Size (H.P.)	Running Watts	Watts Required to Start Motor		
		Repulsion Induction	Capacitor	Split Phase
1/8	275	600	850	1200
1/6	275	600	850	2050
1/4	400	850	1050	2400
1/3	450	975	1350	2700
1/2	600	1300	1800	3600
3/4	850	1900	2600	—
1	1100	2500	3300	—

GROUND FAULT CIRCUIT INTERRUPTER

The 20 amp, 120 volt receptacles on the generator are protected by a Ground Fault Circuit Interrupter (GFCI), which guards against the hazards of ground fault currents. An example of ground fault current is the current that would flow through a person who is using an appliance with faulty insulation and, at the same time, is in contact with an electrical ground such as a plumbing fixture, wet floor, or earth.

GFCI receptacles do not protect against short circuits, overloads, or shocks.

The GFCI receptacles can be tested with the TEST and RESET buttons.

To test:

- Depress the TEST button. This should cause the Reset button to pop out.
- To restore power, depress the RESET button.

Perform this test monthly to ensure proper operation of the GFCI. If the generator is stored outdoors, unprotected from the weather, test the GFCI receptacle before each use.

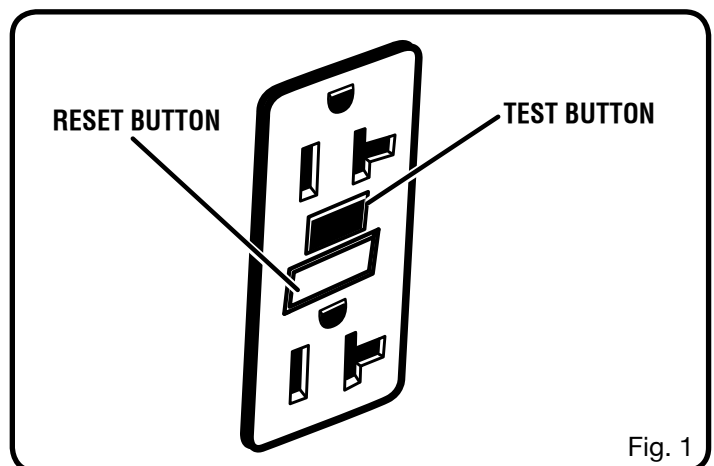

Fig. 1

ELECTRICAL

GENERATOR CAPACITY

Make sure the generator can supply enough continuous (running) and surge (starting) watts for the items you will power at the same time. Follow these simple steps.

1. Select the items you will power at the same time.
2. Total the continuous (running) watts of these items. This is the amount of power the generator must produce to keep the items running. See the wattage reference chart at right.
3. Estimate how many surge (starting) watts you will need. Surge wattage is the short burst of power needed to start electric motor-driven tools or appliances such as a circular saw or refrigerator. Because not all motors start at the same time, total surge watts can be estimated by adding only the item(s) with the highest additional surge watts to the total rated watts from step 2.

Example:

Tool or Appliance	Continuous (Running) Watts	Surge (Starting) Watts
Window AC, 10,000 BTU	1200	1800
Refrigerator	700	2200
1/3 HP Well Pump	1000	2000
27 in. Television	500	0
Light (75 Watts)	75	0
	3475 Total Running Watts	2200 Highest Surge Watts

Total Continuous (Running) Watts	3475
Plus Highest Additional Surge Watts	+ 2200
Equals Total Generator Output Required	5675

POWER MANAGEMENT

To prolong the life of the generator and attached devices, it is important to take care when adding electrical loads to the generator. There should be nothing connected to the generator outlets before starting its engine. The correct and safe way to manage generator power is to sequentially add loads as follows:

1. With nothing connected to the generator, start the engine as described later in this manual.
2. Plug in and turn on the first load, preferably the largest load you have.
3. Permit the generator output to stabilize (engine runs smoothly and attached device operates properly).
4. Plug in and turn on the next load.
5. Again, permit the generator to stabilize.
6. Repeat steps 4 and 5 for each additional load.

Never add more loads than the generator capacity. Take special care to consider surge loads in generator capacity as previously described.

CAUTION:

Do not overload the generator's capacity. Exceeding the generator's wattage/amperage capacity can damage the generator and/or electrical devices connected to it.

Tool or Appliance	Typical Continuous* (Running) Watts	Typical Surge (Starting) Watts
Essentials		
Light Bulb – 75 Watt	75	75
Refrigerator/Freezer	700	2200
Sump Pump – 1/2 HP	1050	2200
Water Well Pump – 1/3 HP	1000	1500
Electric Water Heater	4000	0
Heating/Cooling		
Furnace Fan – 1/2 HP	800	2350
Window AC – 10,000 BTU	1200	1800
Space Heater	1800	0
Kitchen		
Microwave Oven – 1000 Watt	1000	0
Coffee Maker	1000	0
Electric Stove – Single Element	2100	0
Toaster Oven	1200	0
Family Room		
VCR	100	0
CD/DVD Player	100	0
Stereo Receiver	450	0
Color Television – 27 in.	500	0
Other		
Security System	500	0
Curling Iron	1500	0
Garage Door Opener – 1/2 HP	875	2350
Hair Dryer – 1/2 HP	1250	0
DIY/Job Site		
Quartz Halogen Work Light	1000	0
Airless Sprayer – 1/3 HP	600	1200
Reciprocating Saw	960	0
Electric Drill – 1/2 HP	600	900
Circular Saw – 7-1/4 in.	1400	2300
Miter Saw – 10 in.	1800	1800
Planer/Jointer – 6 in.	1800	1800
Table Saw/Radial Arm Saw – 10 in.	2000	2000
Air Compressor – 1 HP	1600	4500

*Wattages listed are approximate. Check tool or appliance for actual wattage.

FEATURES

PRODUCT SPECIFICATIONS

ENGINE

Engine Type	4 Stroke, Overhead Valve
Bore x Stroke.....	88 mm x 64 mm
Cooling System	Forced Air
Compression Ratio.....	8:1
Starting System.....	Recoil
Ignition System.....	T.C.I.
Spark Plug.....	TORCH F7RTC
Engine Oil Volume	1.2 qt.
Fuel Volume.....	6.5 gal.

GENERATOR

Rated Voltage	120V/240V
Rated Amps.....	22.9A
Rated Output.....	5,500 W
Maximum Output	6,000 W
Rated Frequency	60 Hz

DIMENSIONS

Length	32.67 in.
Width	26.77 in.
Height.....	24.6 in.
Net Weight.....	202 lbs.

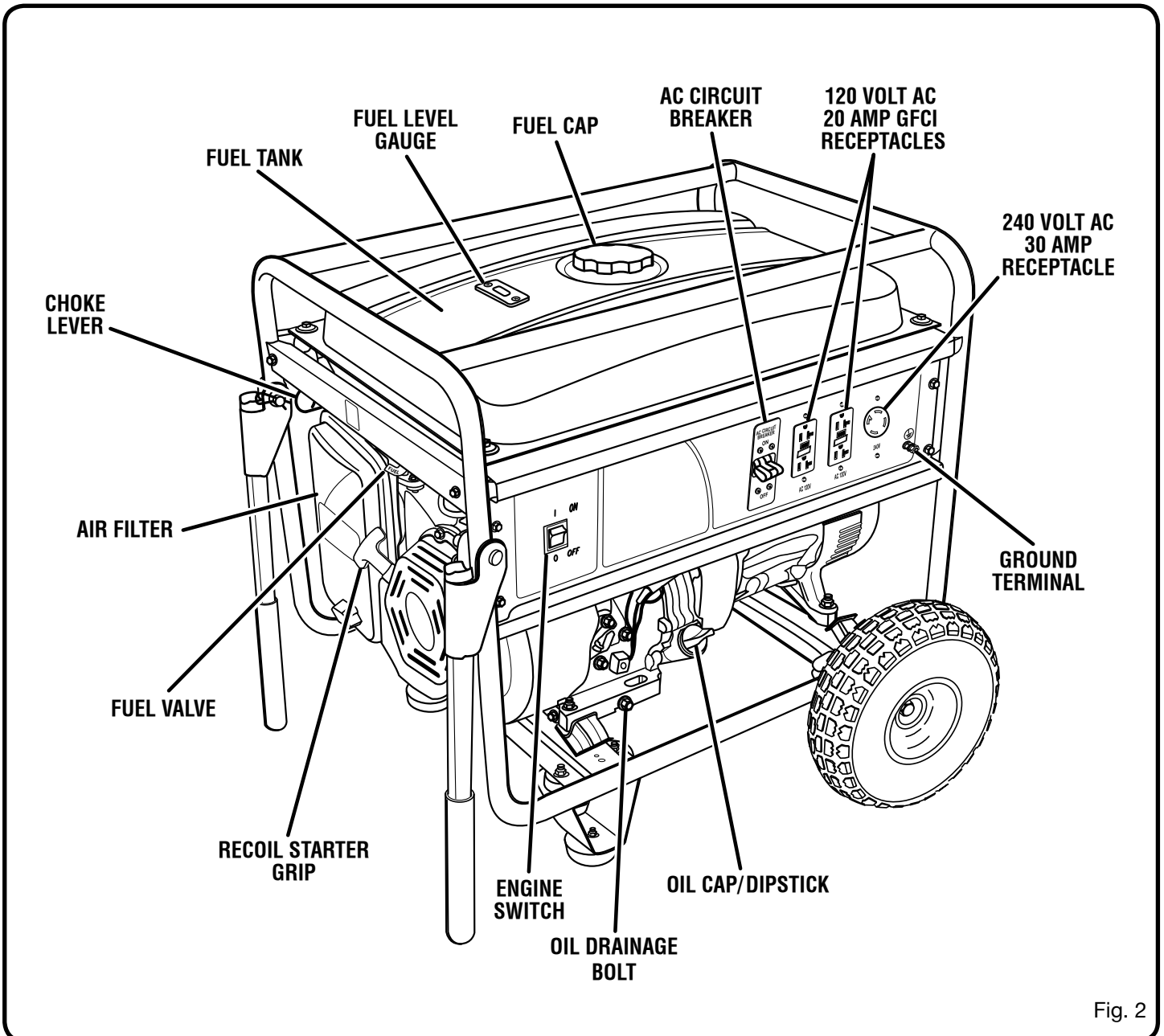

Fig. 2

FEATURES

KNOW YOUR GENERATOR

See Figure 2.

The safe use of this product requires an understanding of the information on the product and in this operator's manual as well as a knowledge of the project you are attempting. Before use of this product, familiarize yourself with all operating features and safety rules.

AC CIRCUIT BREAKER

The circuit breaker is provided to protect the generator against electrical overload and can be used to turn the generator's electrical power on or off.

AIR FILTER

The air filter helps to limit the amount of dirt and dust drawn into the unit during operation.

CHOKE LEVER

The choke lever is used when starting the engine.

ENGINE SWITCH

The engine switch is used in combination with the recoil starter grip to start the generator. It is also used to turn the generator off.

FUEL LEVEL GAUGE

Consult the fuel level gauge to determine the amount of fuel remaining in the generator.

FUEL TANK

The fuel tank has a capacity of 6.5 gallons.

FUEL VALVE

The flow of fuel through the generator is controlled by the position of the fuel valve.

GROUND TERMINAL

The ground terminal is used to assist in properly grounding the generator to help protect against electrical shock. Consult with a local electrician for grounding requirements in your area.

OIL DRAINAGE BOLT

When changing the engine oil, the oil drainage bolt is loosened to allow old engine oil to be drained.

OIL CAP/DIPSTICK

Remove the oil fill cap to check and add oil to the generator when necessary.

RECEPTACLES

Your generator has the following single phase, 60 Hz outlets: four 120 Volt AC, 20 Amp GFCI receptacles, and one 240 Volt AC, 30 Amp receptacle. These can be used for operating appropriate appliances, electrical lighting, tools, and motor loads.

RECOIL STARTER GRIP

The recoil starter grip is used (along with the engine switch) to start the generator's engine.

LOOSE PARTS LIST

The following items are included with the generator:

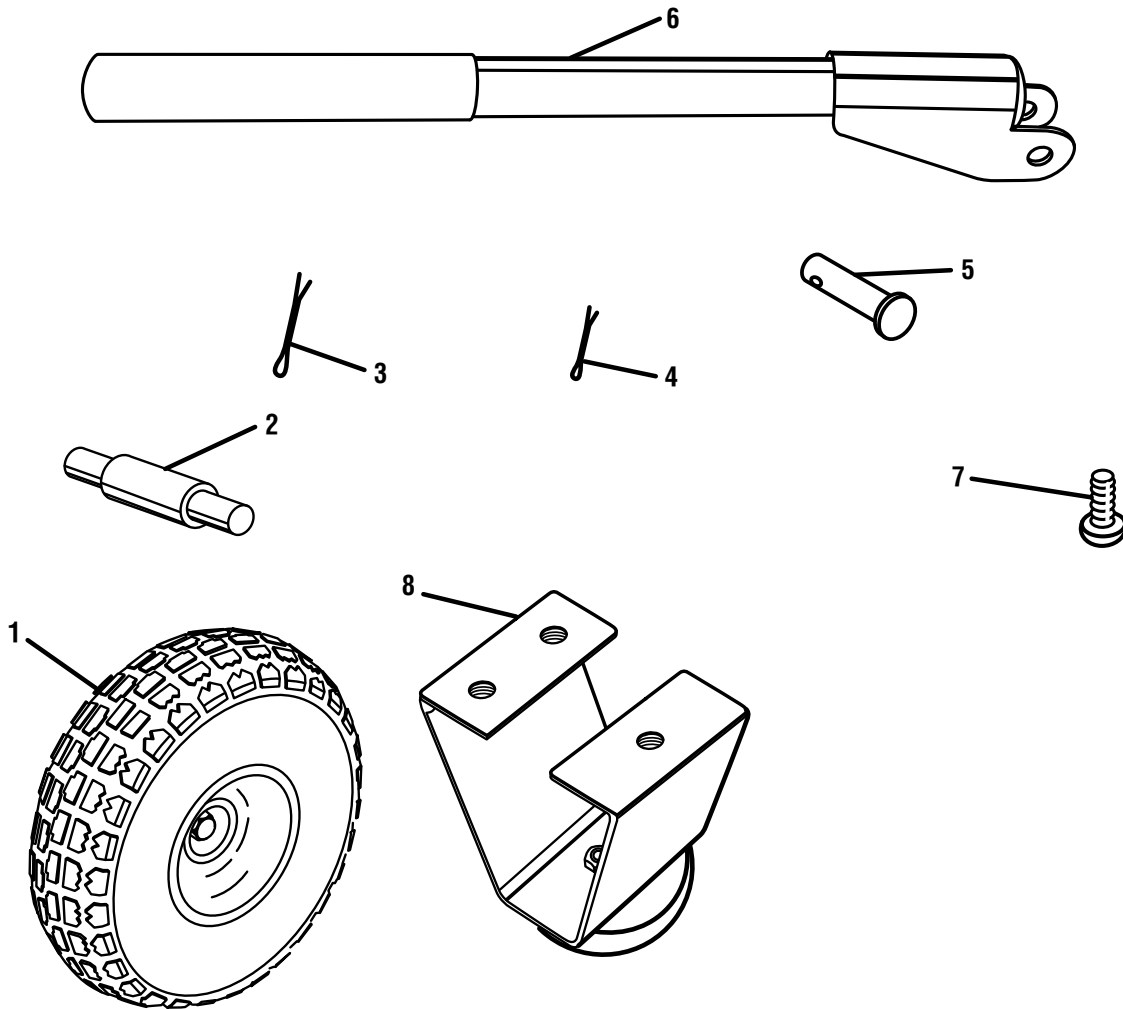

Key No.	Description.....	Qty.
1	Wheels.....	2
2	Wheel Axle.....	2
3	Large Cotter Pin	2
4	Small Cotter Pin	4
5	Clevis Pin.....	2
6	Handle	2

Key No.	Description.....	Qty.
7	Bolt	6
8	Frame Support with Foot	2
	10W-30 4-Cycle Engine Oil (34 fl. oz., not shown)	1
	Registration Card (not shown).....	1
	Operator's Manual (not shown)	1

ASSEMBLY

UNPACKING

This product requires assembly.

- Remove one end of the box and carefully slide out the generator and any accessories.

NOTE: The generator is heavy. If you must lift the unit out of the box, get another person to help you and lift with your legs, not your back.

- Inspect the unit carefully to make sure no damage occurred during shipping.
- Do not discard the packing material until you have carefully inspected and satisfactorily operated the product.
- If any parts are damaged or missing, please call 1-866-260-8280 for assistance.

WARNING:

If any parts are damaged or missing do not operate this product until the parts are replaced. Failure to heed this warning could result in serious personal injury.

WARNING:

Do not attempt to modify this tool or create accessories not recommended for use with this tool. Any such alteration or modification is misuse and could result in a hazardous condition leading to possible serious personal injury.

WARNING:

Do not attempt to operate the generator until assembly is complete. Failure to comply could result in possible serious personal injury.

INSTALLING THE WHEELS

See Figure 3.

Wheels are provided to assist in moving the generator to the desired location and should be installed on the side opposite the recoil starter.

NOTE: Install the wheels before installing the handle. Do not put fuel or oil in the generator before installing the wheels.

- Locate the following items:
 - 2 wheel axles
 - 2 wheels
 - 2 small cotter pins
 - 2 large cotter pins
- Raise the end of the generator opposite the recoil starter high enough to gain access to the frame bottom; securely position props underneath to support.
- Locate the U-bracket on one side of the frame bottom. Slide a wheel axle through the bracket so that an end extends from both sides of the bracket.
- On the end that extends inside the generator frame, insert a small cotter pin through the hole in the axle to secure. Bend the ends of the cotter pin to prevent the pin from slipping out.

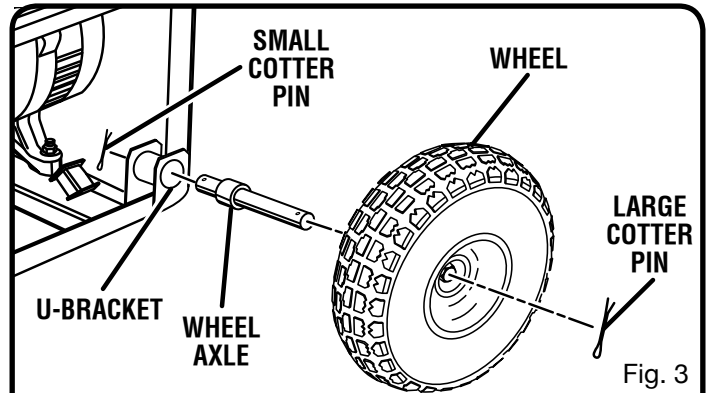

Fig. 3

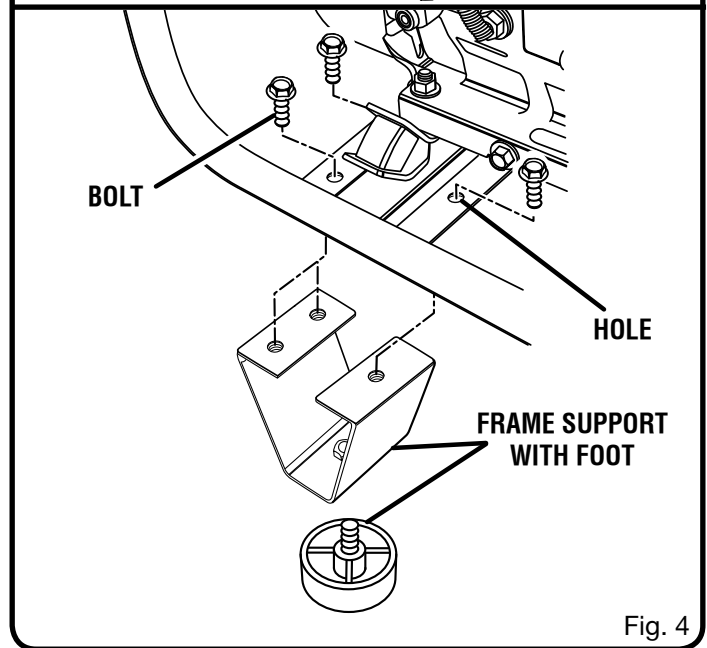

Fig. 4

- Place a wheel over the other end of the axle.
- Insert a large cotter pin through the hole in the axle. Bend the ends of the pin to secure.
- Repeat the process on the other side.

INSTALLING THE FRAME SUPPORTS

See Figure 4.

Install the two frame supports provided on the bottom side of the generator frame opposite the wheels.

- Locate the following items:
 - 2 frame supports
 - 6 bolts
- Raise the end of the generator where the recoil starter is located high enough to gain access to the frame bottom; securely position props underneath to support.
- Align the holes on the frame support with the holes on the generator frame.
- Insert a bolt through the hole in the generator frame so it extends down through the frame support.
- Tighten bolt to secure.
- Repeat with the two remaining screws.
- Repeat on other side to install second frame support.

ASSEMBLY

INSTALLING THE HANDLES

See Figure 5.

- Locate the following items:
 - 2 handles
 - 2 clevis pins
 - 2 small cotter pins
- With the generator in normal operating position, find the holes on the frame above the recoil starter.
- Align the holes in one of the handle brackets with the holes in one side of the generator frame.
- Insert a clevis pin through the handle bracket and frame. The head of the pin should be on the outside of the frame.
- Insert the small cotter pin through the hole in the clevis pin. Bend the ends of the pin to secure.
- Repeat the above steps to install the second handle.

CAUTION

Do not attempt to lift the unit by the handle assembly. If it is necessary to lift the generator, always grasp by the frame. Use proper lifting techniques to avoid back injury.

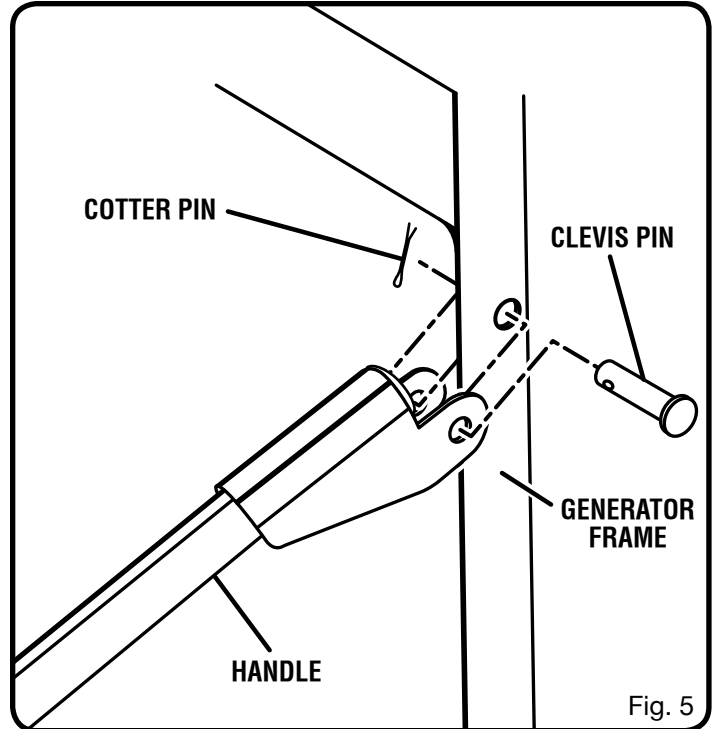

OPERATION

DANGER:

Failure to properly ground generator can result in electrocution, especially if the generator is equipped with a wheel kit. National Electric Code requires generator to be properly grounded to an approved earth ground. Call an electrician for local grounding requirements.

WARNING:

Do not allow familiarity with tools to make you careless. Remember that a careless fraction of a second is sufficient to inflict serious injury.

WARNING:

Do not use any attachments or accessories not recommended by the manufacturer of this product. The use of attachments or accessories not recommended can result in serious personal injury.

APPLICATIONS

This generator is designed to supply electrical power for operating compatible electrical lighting, appliances, tools, and motor loads.

OPERATION

BEFORE OPERATING THE UNIT

Position the generator on a flat surface before checking fluid levels or adding fluid.

CAUTION:

Attempting to start the engine before it has been properly filled with oil will result in equipment failure.

CHECKING/ADDING OIL

See Figure 6.

Engine oil has a major influence on engine performance and service life. For general, all-temperature use, SAE 10W-30 is recommended. Always use a 4-stroke motor oil that meets or exceeds the requirements for API service classification SJ.

NOTE: Non-detergent or 2-stroke engine oils will damage the engine and should not be used.

- Unscrew the oil cap/dipstick and remove.
- Wipe dipstick clean and re-seat in hole; do not re-thread.
- Remove dipstick again and check oil level. Oil level should fall within the hatched area on the dipstick.
- If level is low, add engine oil until the fluid level rises to the upper portion of the hatched area on the dipstick.
- Replace and secure the oil cap/dipstick.

CHECKING/ADDING FUEL

See Figure 7.

- Check the fuel level gauge. If fuel is needed, continue with the next step.
- Remove the fuel cap.
- Fill the fuel tank to 1 in. below the top of the fuel neck.
- Replace and secure the fuel cap.

NOTE: Always use unleaded gasoline with a pump octane rating of 86 or higher. Never use old, stale, or contaminated gasoline, and do not use an oil/gas mixture. Do not allow dirt or water into the fuel tank.

USING FUEL STABILIZER

Fuel gets old, oxidizes, and breaks down over time. Adding a fuel stabilizer extends the usable life of fuel and helps prevent deposits from forming that can clog the fuel system. Follow fuel stabilizer manufacturer's directions for correct ratio of stabilizer to fuel.

- Add stabilizer to fuel tank, then fill with gasoline following previous instructions.

NOTE: Fuel stabilizer and gasoline can be mixed prior to filling the tank by using a gas can or other approved fuel container and shaking gently to combine.

- Replace and secure the fuel tank cap.
- Start and run the engine for at least 5 minutes to allow stabilizer to treat the entire fuel system.

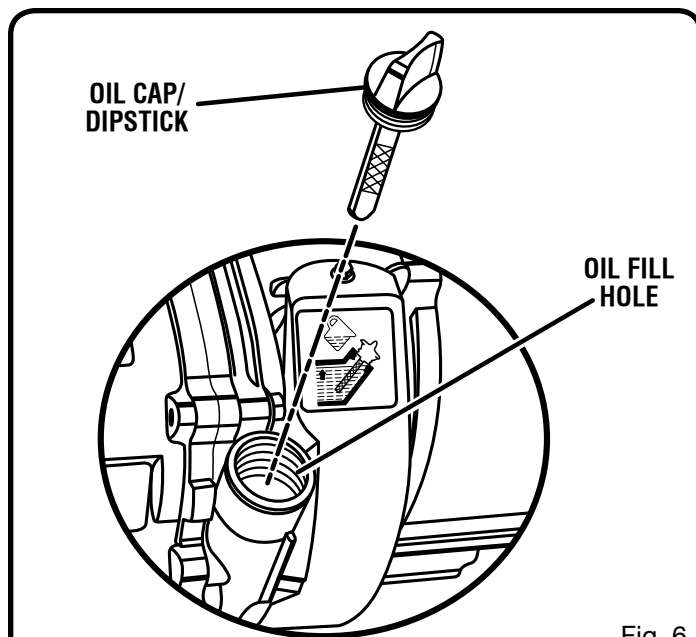

Fig. 6

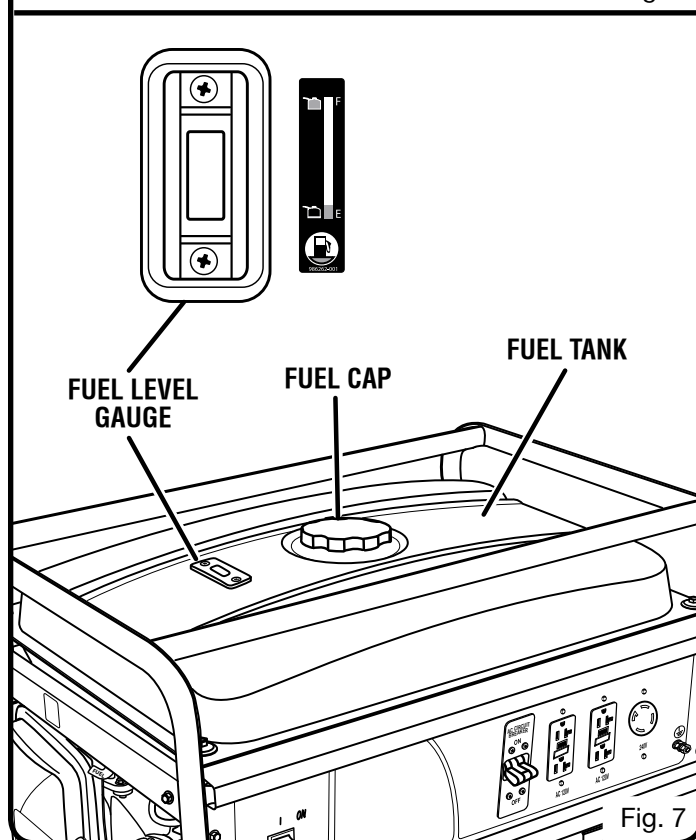

Fig. 7

OXYGENATED FUELS

Some conventional gasolines are blended with alcohol or an ether compound. These gasolines are collectively referred to as oxygenated fuels. To meet clean air standards, some areas of the United States and Canada use oxygenated fuels to help reduce emissions.

OPERATION

If using an oxygenated fuel, make sure it is unleaded and meets the minimum octane rating requirements. Before using an oxygenated fuel, try to confirm the fuel's contents. Some states/provinces require this information to be posted on the pump. The following are the EPA approved percentages of oxygenates:

Ethanol (ethyl or grain alcohol) 10% by volume. You may use gasoline containing up to 10% ethanol by volume. Gasoline containing ethanol may be marketed under the name "Gasohol."

MTBE (methyl tertiary butyl ether) 15% by volume. You may use gasoline containing up to 15% MTBE by volume.

Methanol (methyl or wood alcohol) 5% by volume. You may use gasoline containing up to 5% methanol by volume as long as it also contains cosolvents and corrosion inhibitors to protect the fuel system. Gasoline containing more than 5% methanol by volume may cause starting and/or performance problems. It may also damage metal, rubber, and plastic parts of the generator or your fuel system.

If you notice any undesirable operating symptoms, try another service station or switch to another brand of gasoline.

NOTE: Fuel system damage or performance problems resulting from the use of an oxygenated fuel containing more than the percentages of oxygenates stated previously are not covered under warranty.

CAUTION:

On a level surface with the engine off, check the oil level before each use of the generator.

STARTING THE ENGINE

See Figures 8 - 10.

NOTE: If location of generator is not level, the unit may not start or may shut down during operation.

- Unplug all loads from the generator.
- Switch the AC circuit breakers to the OFF (O) position.
- Turn the fuel valve to the ON position.
- Pull the choke lever to the START position.

NOTE: If engine is warm or the temperature is above 50°F, push the choke lever in to the RUN position.

- Put the engine switch in the ON (I) position.
- Pull the recoil starting grip until the engine runs (a maximum of 6 times).
- **NOTE:** Do not allow the grip to snap back after starting; return it gently to its original place.
- Allow the engine to run for 30 seconds, then push the choke lever in to the RUN position.
- Switch the AC circuit breakers to the ON position.

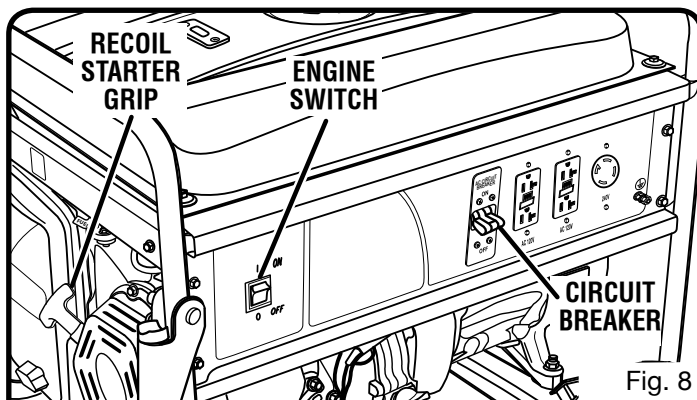

Fig. 8

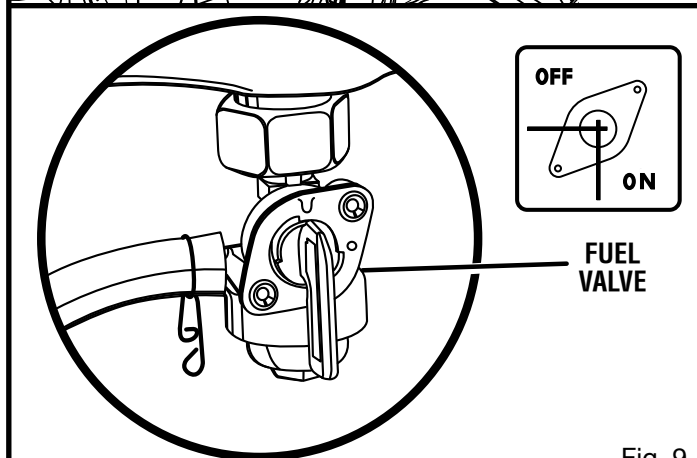

Fig. 9

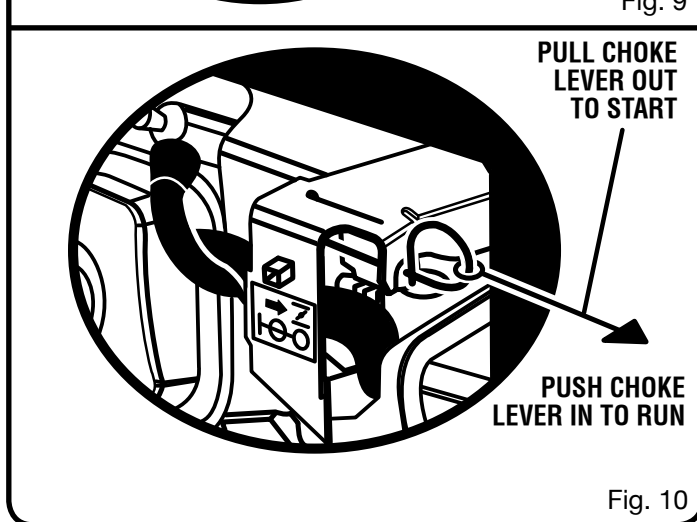

Fig. 10

STOPPING THE ENGINE

See Figures 8 - 9.

To stop the engine under normal operating conditions:

- Remove any load from the generator.
- Place the voltage selector in the center (OFF) position.
- Switch the AC circuit breakers to the OFF position.
- Turn the fuel valve to the OFF position.
- Put the engine switch in the OFF (O) position.

To stop the engine in an emergency situation:

- Put the engine switch in the OFF (O) position.

MAINTENANCE

WARNING:

When servicing, use only identical Homelite replacement parts. Use of any other parts may create a hazard or cause product damage.

Only the parts shown on the parts list are intended to be repaired or replaced by the customer. All other parts should be replaced at a Baja authorized service center.

GENERAL MAINTENANCE

Keep the generator in a clean and dry environment where it is not exposed to dust, dirt, moisture, or corrosive vapors. Do not allow the cooling air slots in the generator to become clogged with foreign material such as leaves, snow, etc.

Do not use a garden hose to clean the generator. Water entering the fuel system or other internal parts of the unit can cause problems that will decrease the life of the generator.

To clean the unit:

- Use a soft bristle brush and/or vacuum cleaner to loosen and remove dirt and debris.
- Clean air vents with low pressure air that does not exceed 25 psi.
- Wipe the exterior surfaces of the generator with a damp cloth.

CHECKING/CLEANING AIR FILTER

See Figure 11.

For proper performance and long life, keep air filter clean.

- Rotate the knob counterclockwise to release.
- Lift the air filter cover toward you and up to remove from the air filter unit.
- Remove the filter element.
- If the filter element is dirty, clean with warm, soapy water. Rinse and let dry.
- Apply a light coat of engine oil to the elements, then squeeze it out.
- Replace the element in the air filter unit.
- Replace the air filter cover.
- Reinstall the knob and rotate clockwise to secure.

NOTE: Do not run the generator without the air filter. Rapid engine wear will result.

CHANGING ENGINE OIL

See Figure 12.

- Remove the oil cap/dipstick.
- Place a container underneath the oil drainage bolt to collect used oil as it drains.

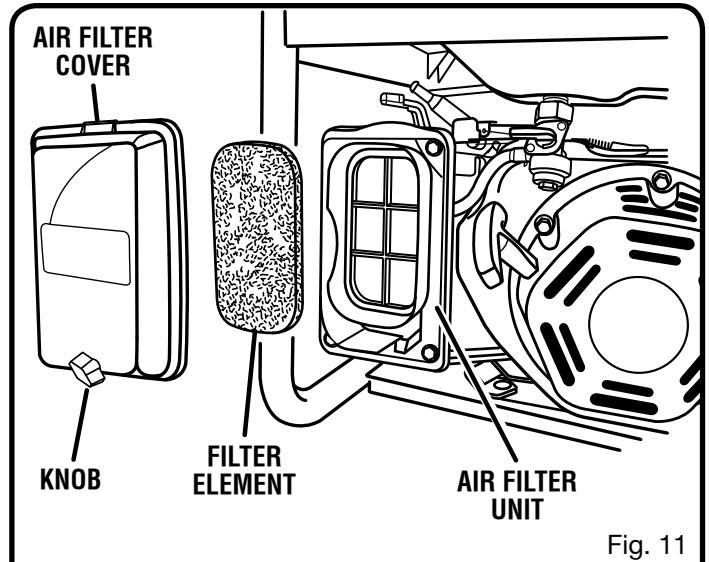

Fig. 11

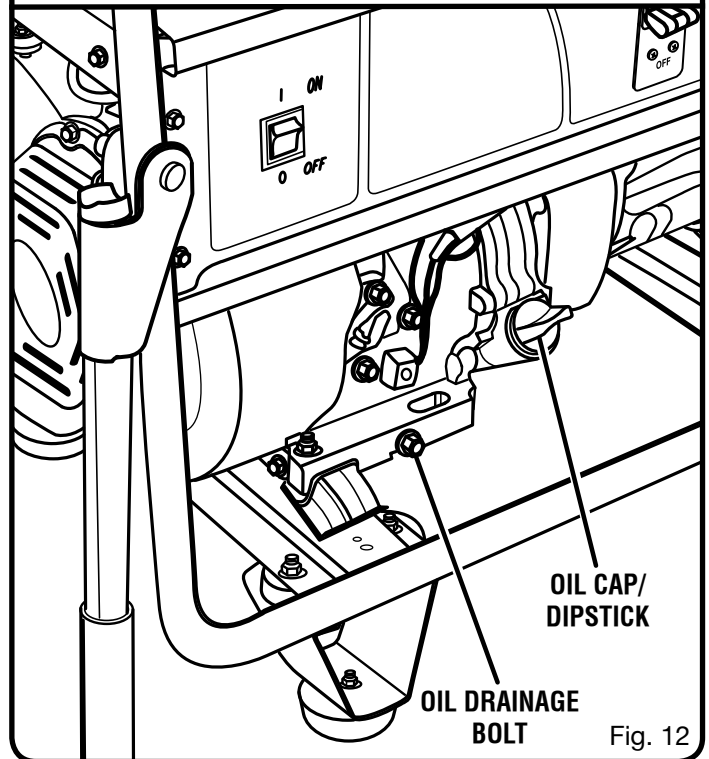

Fig. 12

- Unscrew the oil drainage bolt and remove.
- Allow oil to drain completely.
- Reinstall the oil drainage bolt and tighten securely.
- Refill with oil following the instructions in the **Checking/Adding Oil** section.
- Reinstall the oil cap/dipstick.

NOTE: Used oil should be disposed of at an approved disposal site. See your local oil retailer for more information.

MAINTENANCE

CLEANING FUEL SEDIMENT CUP

See Figure 13.

The sediment cup prevents dirt and water that may have gotten into the fuel tank from entering the carburetor. If the engine has not been run for a long time, the sediment cup should be cleaned before use.

- Turn the fuel valve to the OFF position.
- Remove the sediment cup using a 10 mm wrench (not provided).
- Remove the O-ring and filter.
- Clean each of the parts in carburetor cleaner or any comparable cleaning product.
- Reinstall the filter, O-ring, and sediment cup. Tighten with wrench to secure.
- Return the fuel valve to ON position and check for leaks.

SPARK PLUG MAINTENANCE

See Figure 14.

The spark plug must be properly gapped and free of deposits in order to ensure proper engine operation. To check:

- Remove the spark plug cap.
- Clean any dirt from around base of spark plug.
- Remove spark plug using wrench provided.
- Inspect spark plug for damage, and clean with a wire brush before reinstalling. If insulator is cracked or chipped, spark plug should be replaced.

NOTE: If replacing, use the following recommended spark plugs or equivalent: Champion RN9YC or NGK BPR5ES.

- Measure plug gap. The correct gap is 0.028–0.031 in. (0.7–0.8 mm). To widen gap, if necessary, carefully bend the ground (top) electrode. To lessen gap, gently tap ground electrode on a hard surface.
- Seat spark plug in position; thread in by hand to prevent cross-threading.
- Tighten with wrench to compress washer. If spark plug is new, use 1/2 turn to compress washer appropriate amount. If reusing old spark plug, use 1/8 to 1/4 turn for proper washer compression.

NOTE: An improperly tightened spark plug will become very hot and could damage the engine.

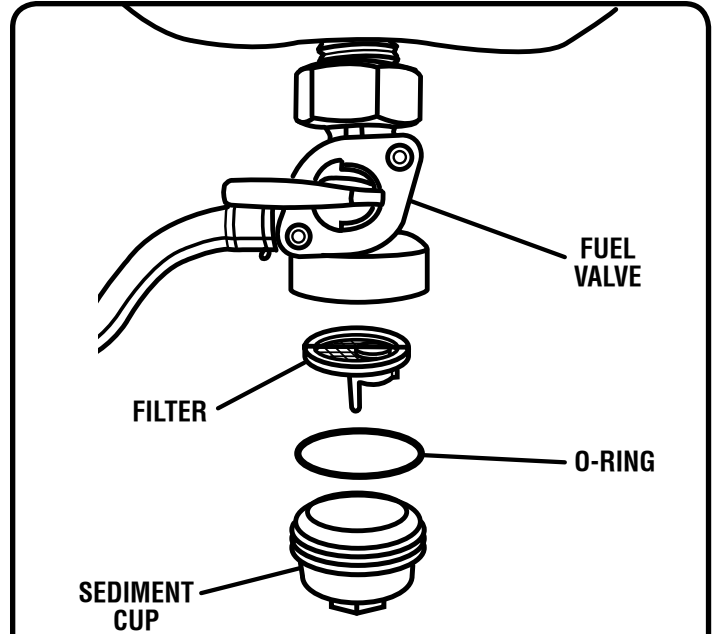

Fig. 13

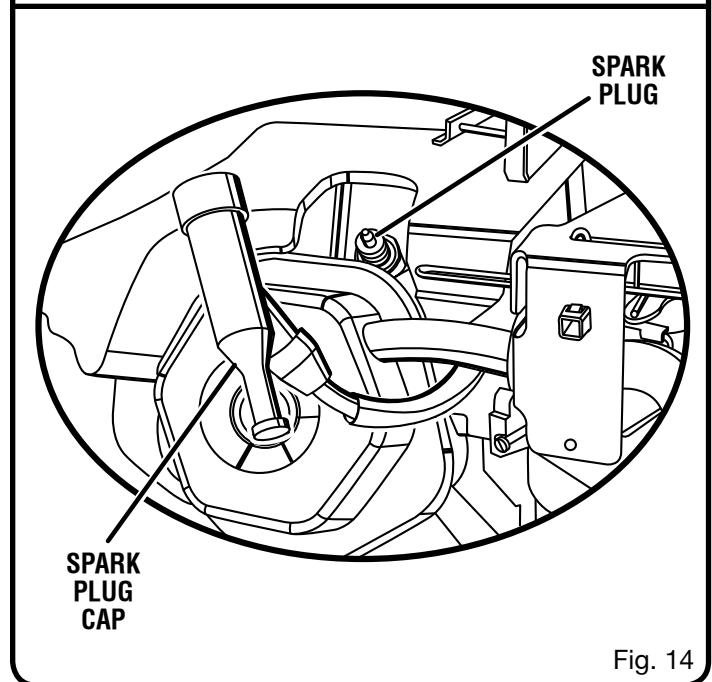

Fig. 14

MAINTENANCE

CLEANING THE EXHAUST PORT AND MUFFLER

Depending on the type of fuel used, the type and amount of oil used, and/or your operating conditions, the exhaust port and muffler may become blocked with carbon deposits. If you notice a power loss with your gas-powered tool, you may need to remove these deposits to restore performance. We highly recommend that only qualified service technicians perform this service.

SPARK ARRESTOR

Product users on United States Forest Service land, and in some states, must comply with fire prevention regulations. This product is not equipped with a spark arrestor. To purchase a spark arrestor for the generator, contact Baja customer service at 1-866-260-8280 and request part number H60-130.

DRAINING FUEL TANK/CARBURETOR

See Figures 15 - 16.

When not using a fuel stabilizer, draining the fuel from the tank and carburetor before storage may help prevent gum deposits in the fuel system.

DRAINING THE FUEL TANK

- Turn the engine switch OFF (O).
- Close fuel valve.
- Remove the fuel line from the petcock by squeezing the ends of the retaining clip and sliding the fuel line off.
- Install one end of a drain line over the petcock, and place the other end in a fuel container large enough to catch the fuel being drained from the tank.
- Open fuel valve.
- When the fuel has drained from the tank, close the fuel valve and reinstall fuel line on petcock.

DRAINING THE CARBURETOR

- Turn the engine switch OFF (O).
- Close the fuel valve.
- Position a suitable container under the carburetor drain screw to catch fuel; loosen the screw.
- Allow fuel to drain completely into container.
- Retighten drain screw.

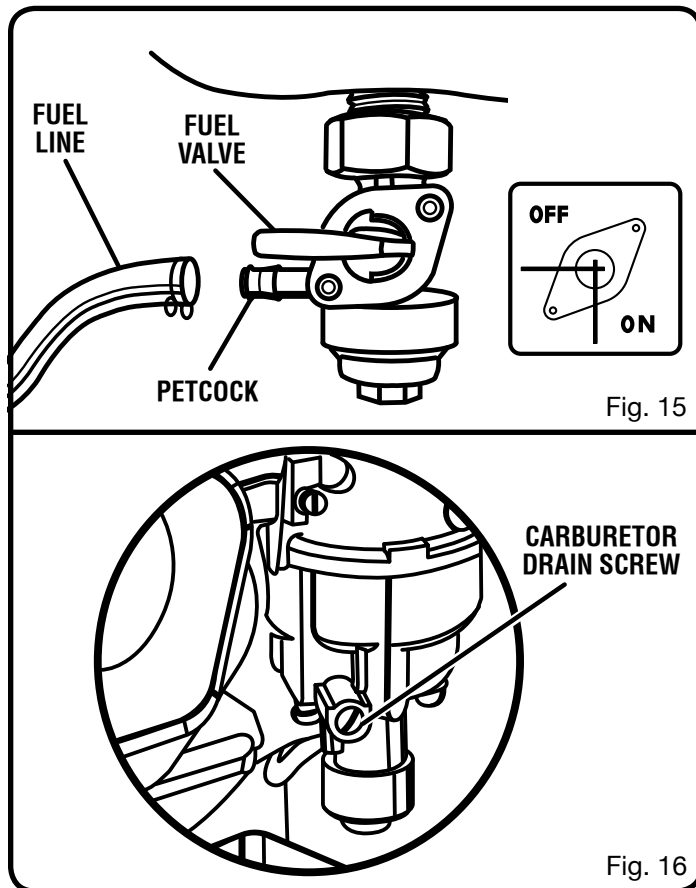

Fig. 15

Fig. 16

NOTE: Consult hazardous waste management guidelines in your area for the proper way to dispose of used fuel.

TRANSPORTING

- Turn engine switch OFF (O).
- Close the fuel valve.
- Make sure engine and exhaust of unit is cool.
- Keep unit level to prevent fuel spillage.
- Do not drop or strike unit or place under heavy objects.

MAINTENANCE

STORAGE

When preparing the generator for storage, follow the guidelines below.

STORAGE TIME	PRIOR TO STORING
Less than 1 month	<ul style="list-style-type: none"> ■ No special preparation is required.
1 to 2 months	<ul style="list-style-type: none"> ■ Fill with fresh gasoline and add a gasoline stabilizer*.
2 months to 1 year	<ul style="list-style-type: none"> ■ Fill with fresh gasoline and add a gasoline stabilizer*. ■ Drain fuel from carburetor. ■ Clean fuel sediment cup.
1 year or more	<ul style="list-style-type: none"> ■ Fill with fresh gasoline and add a gasoline stabilizer*. ■ Drain fuel from the carburetor. ■ Clean fuel sediment cup. ■ Remove spark plug. ■ Put a tablespoon of engine oil into the spark plug cylinder. Turn the engine slowly with the pull rope to distribute the oil. ■ Reinstall spark plug. ■ Change engine oil. <p>After removal from storage:</p> <ul style="list-style-type: none"> ■ Drain and dispose of stored gasoline in a suitable container. ■ Fill with fresh gasoline.

*Use gasoline stabilizers formulated to extend storage life. For recommendations, contact your nearest Baja authorized service center.

MAINTENANCE SCHEDULE

	Before each use	After 1st month or 20 hours of operation	Every 3 months or 50 hours of operation	Every 6 months or 100 hours of operation	Every year or after 300 hours of operation
Check Engine Oil	■				
Change Engine Oil		■		■	
Check Air Filter	■				
Clean Air Filter			■		
Change Air Filter					■
Clean Carburetor Sediment Cup				■	
Check/Adjust Spark Plug				■	
Replace Spark Plug					■
Check/Adjust Idle Speed					■
Check/Adjust Valve Clearance*					■
Clean Fuel Tank and Filter*				■	
Check Fuel Tube					■

* These items should only be carried out by a Baja authorized service center.

NOTE: Maintenance should be performed more frequently when generator is used in dusty areas.

When generator has exceeded the maximum figures specified in the table, maintenance should still be cycled according to the intervals of time or hours stated herein.

TROUBLESHOOTING

PROBLEM	POSSIBLE CAUSE	SOLUTION
Engine will not start.	Engine switch is OFF. No fuel. Oil level is low. Fuel valve is OFF. Spark plug faulty, fouled, or improperly gapped. Fuel is not reaching carburetor. Choke is OPEN. Engine stored without treating or draining gasoline, or refueled with bad gasoline.	Turn engine switch to ON. Fill fuel tank. Check engine oil level and fill, if necessary. Turn fuel valve ON. Replace spark plug. Clean fuel sediment cup. Pull choke lever out to CLOSED. Drain fuel and carburetor. Refuel with fresh gasoline.
Engine lacks power.	Fuel element clogged. Engine stored without treating or draining gasoline, or refueled with bad gasoline.	Check air filter element. Clean or replace as needed. Drain fuel and carburetor. Refuel with fresh gasoline.
AC receptacle does not work.	Circuit breaker is OFF. Item plugged in is defective.	Turn ON the AC circuit breaker. Try a different item.
Generator makes a "spark knock" or "pinging" noise.	An occasional light "knocking" or "pinging" under heavy load is not a cause for concern. However, if the knocking or pinging occurs under normal load at a steady engine speed, the problem may be with the brand of gasoline being used.	Switch to a different brand of gasoline, making sure that the octane rating is 86 or higher. If problem continues, contact your nearest Baja authorized service center.
If problem persists after trying the above solutions, contact your nearest Baja authorized service center for assistance.		
The following symptoms may indicate problems that will affect the emissions level of the unit: <ul style="list-style-type: none"> ■ Hard starting or stalling after starting ■ Rough idle ■ Misfiring or backfiring under load ■ Afterburning (backfiring) ■ Black exhaust smoke or high fuel consumption If you encounter any of these symptoms, have the unit inspected and repaired by the nearest Baja authorized service center.		

WIRING DIAGRAM

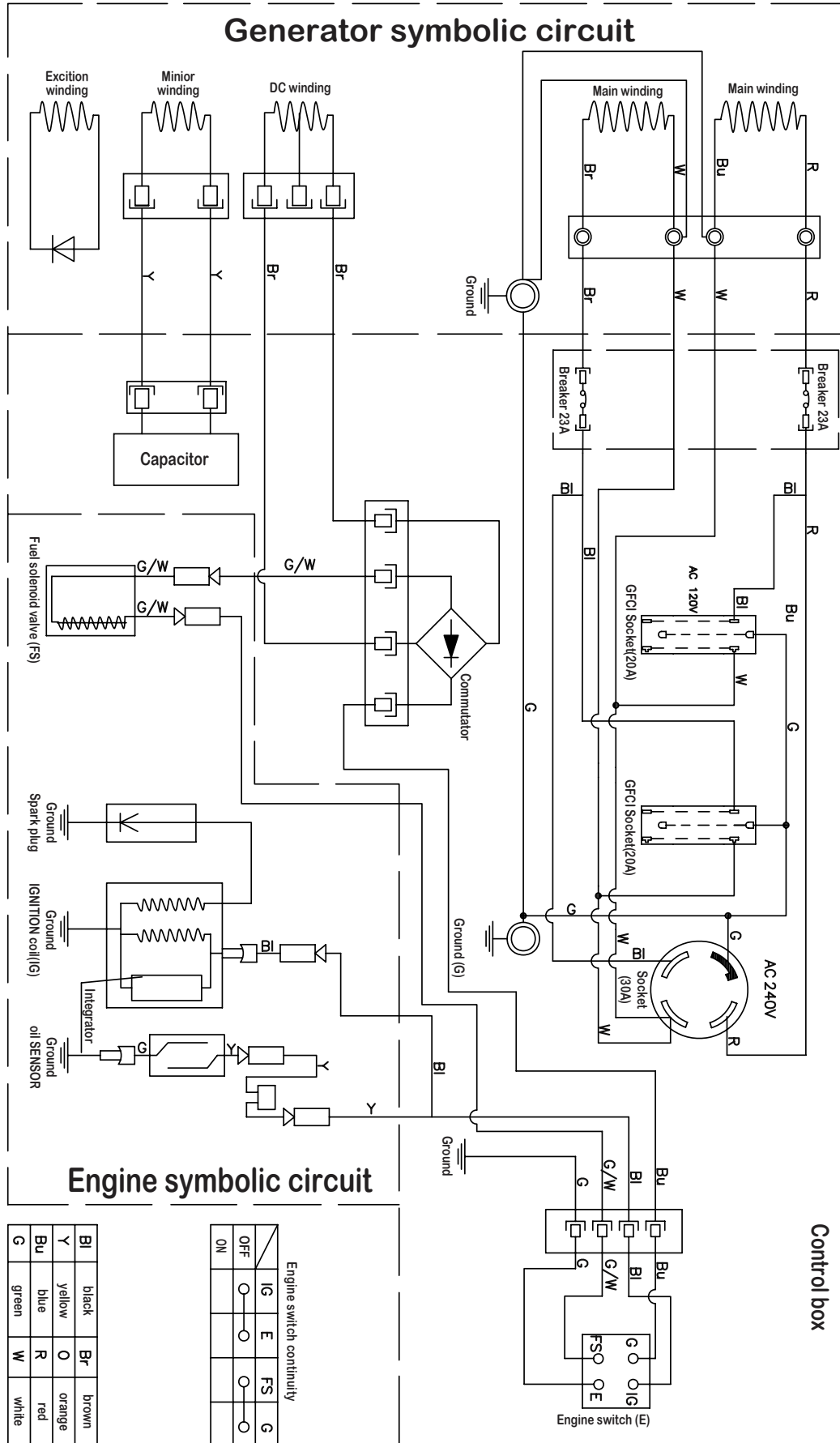

Bl	black	Br	brown
Y	yellow	R	orange
Bu	blue	W	white
G	green		

		Engine switch continuity			
		IG	E	FS	G
OFF	○	○	○	○	
ON	○	○	○	○	

WARRANTY

LIMITED WARRANTY STATEMENT

Baja Motorsports warrants to the original retail purchaser that this HOMELITE brand outdoor product is free from defect in material and workmanship and agrees to repair or replace, at Baja Motorsports', discretion, any defective product free of charge within these time periods from the date of purchase.

- One year if the product is used for personal, family, or household use;
- 90 days if used for any other purpose, such as commercial or rental.

This warranty extends to the original retail purchaser only and commences on the date of the original retail purchase.

Any part of the this product manufactured or supplied by Baja Motorsports and found in the reasonable judgment of Baja Motorsports to be defective in material or workmanship will be repaired or replaced without charge for parts and labor by a Baja authorized service center.

The product, including any defective part, must be returned to a Baja authorized service dealer within the warranty period. The expense of delivering the product to the dealer for warranty work and the expense of returning it back to the owner after repair or replacement will be paid by the owner. Baja Motorsports' responsibility in respect to claims is limited to making the required repairs or replacements and no claim of breach of warranty shall be cause for cancellation or rescission of the contract of sale of any HOMELITE brand product. Proof of purchase will be required by the dealer to substantiate any warranty claim. All warranty work must be performed by a Baja authorized service center.

This warranty is limited to ninety (90) days from the date of original retail purchase for any HOMELITE brand product that is used for rental or commercial purposes, or any other income-producing purpose.

This warranty does not cover any HOMELITE brand product that has been subject to misuse, neglect, negligence, or accident, or that has been operated in any way contrary to the operating instructions as specified in this operator's manual. This warranty does not apply to any damage to the product that is the result of improper maintenance or to any product that has been altered or modified. The warranty does not extend to repairs made necessary by normal wear or by the use of parts or accessories which are either incompatible with the HOMELITE brand product or adversely affect its operation, performance, or durability. In addition, this warranty does not cover:

- A. Tune-ups – Spark Plugs, Carburetor, Carburetor Adjustments, Ignition, Filters, Oil Change
- B. Wear items – Recoil Starter Rope, Engine Brushes, Cotter Pins, Tires

Baja Motorsports reserves the right to change or improve the design of any HOMELITE brand product without assuming any obligation to modify any product previously manufactured.

ALL IMPLIED WARRANTIES ARE LIMITED IN DURATION TO THE STATED WARRANTY PERIOD. ACCORDINGLY, ANY SUCH IMPLIED WARRANTIES INCLUDING MERCHANTABILITY, FITNESS FOR A PARTICULAR PURPOSE, OR OTHERWISE, ARE DISCLAIMED IN THEIR ENTIRETY AFTER THE EXPIRATION OF THE APPROPRIATE ONE-YEAR OR NINETY-DAY WARRANTY PERIOD. BAJA MOTORSPORTS' OBLIGATION UNDER THIS WARRANTY IS STRICTLY AND EXCLUSIVELY LIMITED TO THE REPAIR OR REPLACEMENT OF DEFECTIVE PARTS AND BAJA MOTORSPORTS DOES NOT ASSUME OR AUTHORIZE ANYONE TO ASSUME FOR THEM ANY OTHER OBLIGATION. SOME STATES DO NOT ALLOW LIMITATIONS ON HOW LONG AN IMPLIED WARRANTY LASTS, SO THE ABOVE LIMITATION MAY NOT APPLY TO YOU. BAJA MOTORSPORTS ASSUMES NO RESPONSIBILITY FOR INCIDENTAL, CONSEQUENTIAL, OR OTHER DAMAGES INCLUDING, BUT NOT LIMITED TO, EXPENSE OF RETURNING THE PRODUCT TO A BAJA AUTHORIZED SERVICE CENTER AND EXPENSE OF DELIVERING IT BACK TO THE OWNER, MECHANIC'S TRAVEL TIME, TELEPHONE OR TELEGRAM CHARGES, RENTAL OF A LIKE PRODUCT DURING THE TIME WARRANTY SERVICE IS BEING PERFORMED, TRAVEL, LOSS OR DAMAGE TO PERSONAL PROPERTY, LOSS OF REVENUE, LOSS OF USE OF THE PRODUCT, LOSS OF TIME, OR INCONVENIENCE. SOME STATES DO NOT ALLOW THE EXCLUSION OR LIMITATION OF INCIDENTAL OR CONSEQUENTIAL DAMAGES, SO THE ABOVE LIMITATION OR EXCLUSION MAY NOT APPLY TO YOU.

This warranty gives you specific legal rights, and you may also have other rights which vary from state to state.

This warranty applies to all HOMELITE brand products manufactured by or for Baja Motorsports and sold in the United States and Canada.

To locate your nearest Baja authorized service center, dial 1-866-260-8280 or log on to our website at www.bajamotorsports.net.

