

LITTLE WONDER[®]

OPTIMAX

Self Propelled Maximum Output Blower

- MODELS:** **9270-12-01**
 GX270 HONDA SP
- 9270-13-01**
 EX270 SUBARU SP
- 9390-12-01**
 GX390 HONDA SP
- 9400-13-01**
 EX400 SUBARU SP
- 9570-14-01**
 570 VANGUARD SP



**Owners Manual and Safety Instructions for
OPTIMAX BLOWER**

MAN 4166799

Rev. A 07-2011

Original Language Instructions

OPERATORS / PARTS MANUAL

CALIFORNIA

Proposition 65 Warning

Diesel engine exhaust and some of its constituents are known to the State of California to cause cancer, birth defects and other reproductive harm.

⚠ WARNING

The engine exhaust from this product contains chemicals known to the State of California to cause cancer, birth defects or other reproductive harm.

CALIFORNIA

Proposition 65 Warning

Battery posts, terminals, wiring insulation, and related accessories contain lead and lead compounds, chemicals known to the State of California to cause cancer and birth defects or other reproductive harm.

WASH HANDS AFTER HANDLING.

LITTLE WONDER BLOWER

IMPORTANT MESSAGE

On behalf of everyone at Little Wonder, we would like to thank you for your purchase of a Little Wonder Gasoline Powered Optimax Blower. This professional blower was designed to the highest standards to ensure you many hours of uninterrupted service.

This manual provides the information necessary for safe and efficient operation and service. For your safety, it is critically important that you read and understand this entire manual before operating your blower.

LITTLE WONDER
SCHILLER GROUNDS CARE, INC.
1028 STREET ROAD, P.O. BOX 38
SOUTHAMPTON, PA 18966

TABLE OF CONTENTS	FIGURES	PAGE
SAFETY.....		4-8
SET UP INSTRUCTIONS.....		9-10
CONTROLS.....		11
OPERATION / MAINTENANCE		12
ADJUSTMENTS.....		13
STORAGE / TORQUE SPECIFICATIONS.....		14
INTAKE GUARD ASSY	FIGURE 1	15
ENGINE ASSY	FIGURE 2	16
HOUSING ASSY	FIGURE 3	17
WARRANTY		BACK COVER

MANY USES:

The extreme versatility offered by Little Wonder's line of blowers makes them ideally suited for a wide variety of jobs; blowing leaves, grass clippings, thatch, blowing tennis courts dry, cleaning large driveways, stadiums, parking lots and other hard surfaces, precleaning roofs before repair and countless other jobs.



This Operator's Manual is part of the machine. Suppliers of both new and second-hand machines must make sure that this manual is provided with the machine.

NOTICE !!!

Unauthorized modifications may present **extreme** safety hazards to operators and bystanders and could also result in product damage.

Schiller Grounds Care, Inc. strongly warns against, rejects and disclaims any modifications, add-on accessories or product alterations that are not designed, developed, tested and approved by Schiller Grounds Care, Inc. Engineering Department. Any Schiller Grounds Care, Inc. product that is altered, modified or changed in any manner not specifically authorized after original manufacture-including the addition of "after-market" accessories or component parts not specifically approved by Schiller Grounds Care, Inc. will result in the Schiller Grounds Care, Inc. Warranty being voided.

Any and all liability for personal injury and/or property damage caused by any unauthorized modifications, add-on accessories or products not approved by Schiller Grounds Care, Inc. will be considered the responsibility of the individual(s) or company designing and/or making such changes. Schiller Grounds Care, Inc. will vigorously pursue full indemnification and costs from any party responsible for such unauthorized post-manufacture modifications and/or accessories should personal injury and/or property damage result.



This symbol means:
ATTENTION!
BECOME ALERT!

Your safety and the safety of others is involved.

Signal word definitions:

The signal words below are used to identify levels of hazard seriousness. These words appear in this manual and on the safety labels attached to Schiller Grounds Care, Inc. machines. For your safety and the safety of others, read and follow the information given with these signal words and/or the symbol shown above.

DANGER

DANGER indicates an imminently hazardous situation which, if not avoided, **WILL** result in death or serious injury.

WARNING

WARNING indicates a potentially hazardous situation which, if not avoided, **COULD** result in death or serious injury.

CAUTION

CAUTION indicates a potentially hazardous situation which, if not avoided, **MAY** result in minor or moderate injury. It may also be used to alert against unsafe practices or property damage.

CAUTION

CAUTION used without the safety alert symbol indicates a potentially hazardous situation which, if not avoided, **MAY** result in property damage.

Schiller Grounds Care, Inc.

1028 Street Road
Southampton, PA 18966 U.S.A
Phone: 215-357-5110
Fax: 215-357-8045

MODEL NUMBER

SERIAL NUMBER

MODEL NUMBER: This number appears on sales literature, technical manuals and price lists.

SERIAL NUMBER: This number appears only on your unit. It contains the model number followed consecutively by the serial number. Use this number when ordering parts or seeking warranty information.

MACHINE PREPARATION

Operator preparation and training

Read the Operation & Safety Manual

- If an operator or mechanic cannot read English, it is the owner's responsibility to explain this material to them. If any portion of this material is unclear, contact your factory representative for clarification.
- Become familiar with the safe operation of the equipment, operator controls and safety signs. Be prepared to stop the engine quickly in an emergency. Do not operate or allow another person to operate this machine if there are any questions about safety.
- All operators and mechanics should be trained. The owner is responsible for training the users.
- Wear appropriate clothing, including safety goggles or safety glasses with side shields when operating. Wear substantial footwear. Do not operate barefoot or wearing open sandals. Long hair, loose clothing or jewelry may get tangled in moving parts.
- Wear appropriate hearing protection.
- Wear dust mask to avoid breathing dust.
- Wear safety glasses.
- Never allow children, unskilled or improperly trained people to operate this equipment. Local regulations can restrict the age of the operator.
- Keep warning labels and this operator's manual legible and intact. Replacement labels and manuals are available from the factory.
- Do not operate machine while under the influence of drugs or alcohol, or any other condition of impairment.
- The owner/user can prevent and is responsible for accidents or injuries occurring to themselves, other people or property.



SITE PREPARATION AND CIRCUMSTANCES

- Evaluate the terrain to determine how to safely perform the job. Only use accessories and attachments approved by the manufacturer.
- Be sure the area is clear of pets and people, especially young children. Never assume they will remain where you last saw them. Stop the machine if any enter the area.

MULTIPLE OPERATORS

- Keep a safe distance between operators when working together.

MACHINE PREPARATION

- Do not tamper with or defeat safety devices. Keep guards, shields and interlock safety devices in place and in proper working condition. They are for your protection.
- Keep all fasteners such as nuts, bolts and pins well secured.
- Verify that machine and attachments, if any, are in good operating condition.

OPERATING SAFELY

IN GENERAL

- Use extra care when loading or unloading the machine into a trailer or truck.
- Do not run the engine in an enclosed area where dangerous carbon monoxide fumes can collect.
- Never leave a running machine unattended. Always stop engine when leaving the operator position.
- Do not blow towards people, cars, windows, or other items which could be injured or damaged by the blown debris.
- Keep hands away from the blower air intake and outlet.

STARTING

- Start according to instructions in this manual or on the machine.
- Do not change engine governor settings or overspeed the engine. Operating the engine at excessive speed can increase the hazard of personal injury.
- Use extreme caution when reversing.



OPERATING ON SLOPES

USE EXTRACARE WHEN OPERATING ON SLOPES. EVALUATE THE RISKS INVOLVED BEFORE OPERATING ON A SLOPE

- Slopes are a major factor related to slip and fall accidents that sometimes lead to severe injury or death. All slopes require extra caution.
- Do not operate on slopes if uneasy or uncertain. Ultimate responsibility for safe operation on slopes rests with the operator.
- Do not operate on steep slopes. Poor footing could cause a slip and fall accident.
- Keep all movement on slopes slow and gradual.
- Do not operate near drop-offs, ditches or embankments. You could lose your footing or balance or drive the machine off the edge.
- Do not turn on slopes unless necessary, and then turn slowly and downhill when possible.
- Be sure of your footing on slopes.
- Watch for holes, ruts, bumps, rocks and other hidden objects. Uneven terrain could cause a slip and fall accident. Tall grass can hide objects.

INTERRUPTING OPERATION

- Before leaving the operator's position:
 - Park on level ground.
 - Release the traction drive bail.
 - Shut off the engine.
- Stop the engine, and wait until the fan stops moving:
 - before refueling;
- Stop the engine, and disconnect the spark plug wire(s):
 - before clearing blockages;
 - before checking, cleaning or working on the machine;
 - if the machine begins to vibrate abnormally: shut off machine immediately. Inspect and have repairs made as needed before restarting;
 - except for repairs or adjustments as specifically noted, such as for carburetor adjustment, where the engine must be running. Keep hands and feet clear of moving parts in these circumstances.
- Allow the fan to come to a complete stop when stopping operation to clear blockages, unclog, inspect the machine, do maintenance or repair.
- Reduce the throttle setting during engine shut-down and, if the engine is provided with a shut-off valve, turn the fuel off at the conclusion of operation.

MAINTENANCE SAFETY

In general

- Maintain machine according to manufacturer's schedule and instructions for maximum safety and best results.
- Park machine on level ground.
- Never allow untrained personnel to service machine.
- Guards should only be removed by a qualified technician for maintenance or service.
- Adjust or repair only after the engine has been stopped and the fan has stopped moving.
- Disconnect spark plug wire(s) before doing any maintenance.
- Replace parts if worn, damaged or faulty. For best results, always replace with parts recommended by the manufacturer.
- Do not dismantle the machine without releasing or restraining forces which may cause parts to move suddenly.
- Provide adequate support, e.g. jack stands for lifted machine or parts if working beneath.
- Do not put hands or feet near or under rotating parts.
- Clean up spilled oil or fuel thoroughly.
- Replace faulty mufflers.
- To reduce fire hazards, keep the engine, muffler, and fuel storage area free of grass, leaves, debris buildup or grease.

Fans

Do not straighten or weld fans. Replace damaged or failed fans..

Fuel

- Gasoline (petrol) and diesel fuels are flammable; gasoline (petrol) vapors are explosive. Use extra care when handling.
- Store only in containers specifically designed for fuel.



- When refueling or checking fuel level:
 - Stop the engine and allow to cool;
 - Do not smoke;
 - Refuel outdoors only;
 - Use a funnel;
 - Do not overfill;
 - If fuel is spilled, do not attempt to start the engine until the spill is cleaned up and vapors have cleared.
- Replace caps on fuel containers and tanks securely.

Sparks from static electricity can start fires or cause explosions. Flowing fuel can generate static electricity. To prevent static electricity sparks:



- Keep containers electrically grounded. Do not fill containers in a vehicle or on a truck or trailer bed with a plastic liner. Fill containers on the ground away from the vehicle.
- When practical, remove petrol (gasoline) powered equipment from the truck or trailer and refuel it on the ground. If equipment must be refueled on the truck or trailer, refuel from a portable container rather than a dispenser nozzle.
- Keep the dispenser nozzle in contact with the rim of the fuel tank or container opening until fueling is complete. Do not use a nozzle lock-open device.
- If fuel is spilled on clothing change it immediately.

STORAGE SAFETY

- Stop the engine and allow to cool before storing.
- Drain the fuel tank outdoors only.
- Store fuel in an approved container in a cool, dry place.
- Keep the machine and fuel containers in a locked storage place to prevent tampering and to keep children from playing with them.
- Do not store the machine or fuel container near an open flame, spark, or appliance, such as a water heater, or a pilot light.
- Keep petrol (gasoline) storage area free of grass, leaves and excessive grease to reduce fire hazard.
- Clean grass and debris from cutting units, drives, mufflers and engine to help prevent fires.

SAFETY DECALS

An important part of the safety system incorporated in this blower are the warning labels found on the blower. Replace labels if damaged or illegible.

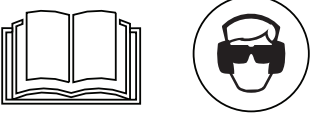
 WARNING	 ADVERTENCIA
	<p>Antes de comenzar:</p> <ul style="list-style-type: none"> -Lea y entienda el manual del operador y las etiquetas. -Pide que alguien lea y explique el manual y las etiquetas a usted si usted no lee Inglés. -Use protección ocular y auditiva. -No haga funcionar sin los protectores en su lugar. -Pare el motor antes de dar servicio -La gente a más durante la operación.
<p>BEFORE STARTING:</p> <ul style="list-style-type: none"> -Read and understand Operator manual and labels. -Wear hearing and eye protection. -Replace labels and Operator manual if lost or damaged. 	<small>4165977</small>

 DANGER

<p>Fan blades can cut/crush.</p> <ul style="list-style-type: none"> -Keep hands and feet away. -Stop engine and remove spark plug wire before servicing. -Do not operate without guards in place.
 WARNING

<p>Thrown objects</p> <ul style="list-style-type: none"> -Keep bystanders away. -Do not blow toward people or pets. -Do not blow toward items that may be damaged by flying debris.
<small>4165975</small>



**D
E
F
L
E
C
T
O
R**



4165913

**F
N
R**



4166816

LITTLE WONDER BLOWER

SET-UP INSTRUCTIONS

SET-UP INSTRUCTIONS

1. Open box. Remove upper handle and cardboard insert.
2. Cut the back of the box open. Use lower handle to roll unit out of the box.
3. Locate hardware package.
4. Install upper handle to lower handle with (4) 3/8-16 x 1-34 carriage bolts and (4) 3/8-16 flanged nylon insert nuts from the hardware package. Tighten the nuts securely but not so much as to crush the tube. (Figure 1) NOTE: There are two handle height positions to choose from.
5. Route the throttle cable in front of lower handle crossbar. Install to the left side of the upper handle with (2) 10-32 x 1/2 thread forming screws from the hardware package. (Figure 2)
6. Ensure the center link of the chain is on the center tooth of the deflector sprocket before connecting the deflector cable. (Figure 3)
7. Route the deflector cable in front of the lower handle cross bar. Remove one of the nuts and the bolts from the end of the deflector cable and install the cable through the key slot into the bracket on the upper handle and reinstall nut and bolt. Move the clevis from the control lever and install over the end of the cable. Reconnect the clevis to the control lever with a 1/4 x 5/8 clevis pin and hairpin cotter. (Note: The deflector can be moved and held in place with the locking knob to help connect the clevis fitting to the control lever. Move the control lever to the rear to more easily connect the cable. Loosen the knob so the deflector moves freely after the clevis is connected.) (Figure 4)



FIGURE 1

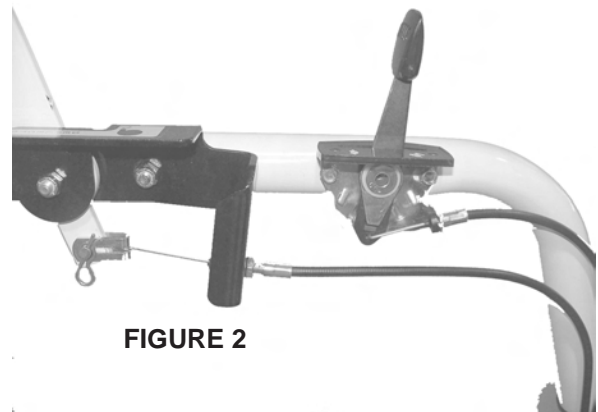

FIGURE 2

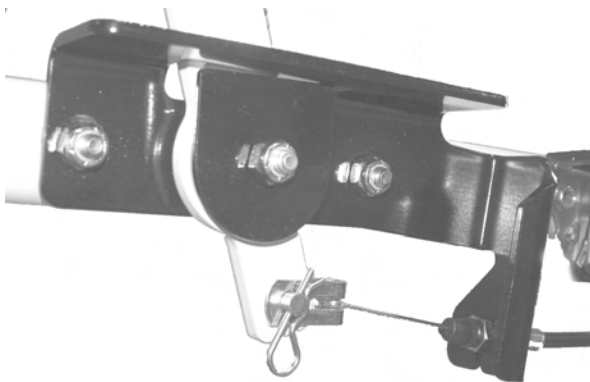

FIGURE 4

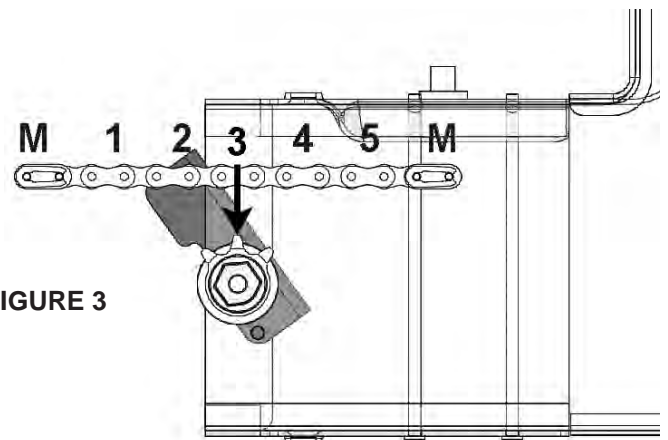

FIGURE 3

SET-UP INSTRUCTIONS

LITTLE WONDER BLOWER

8. Move the deflector control lever to the front of the slot. Adjust the jam nuts on the cable fitting so the deflector is completely closed. Lock the nuts against the bracket when the adjustment is correct.
9. Secure the throttle and deflector cables to the handle tubes with cable ties from the hardware package. Trim off excess. (Figure 5)
10. Move the speed control lever **A** all the way forward. Turn the vertical rod **B** into the swivel **C** on the speed control. Pull up on the rod **B** to move the speed control to its forward stop. Turn the rod in or out of the swivel unit it just goes into the pivot plate **E**. (Use the lower pivot plate hole for the upper handle position.) Secure the rod **B** to the pivot plate **E** with two hairpin cotters. (Figure 6 & 7)
11. Route the clutch cable up the front of the right handle tube and around the outside of the handle. Route as shown in Figure 6 and install the snap retainer **D** in the hole in the speed control bracket. (Figure 6) Lift the clutch bail to get sufficient slack to connect the Z-bend on the end of the clutch to the clutch bail. (If sufficient slack is not available, the bail may be squeezed together and removed from the handle to connect the Z-bend then reinstall. (Figure 8)
12. Secure the clutch cable to the speed control bracket and handle tube with cable ties as shown (Figure 6)
10. Fill the engine with oil to the level indicated on the dipstick. Fill the fuel tank with clean, fresh regular grade unleaded gasoline.

FIGURE 5

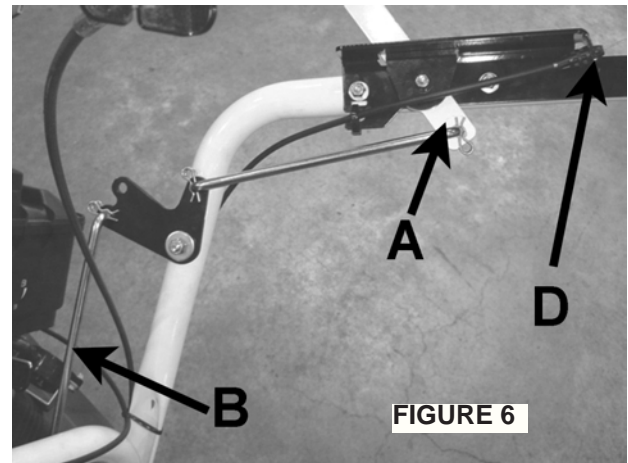

FIGURE 6

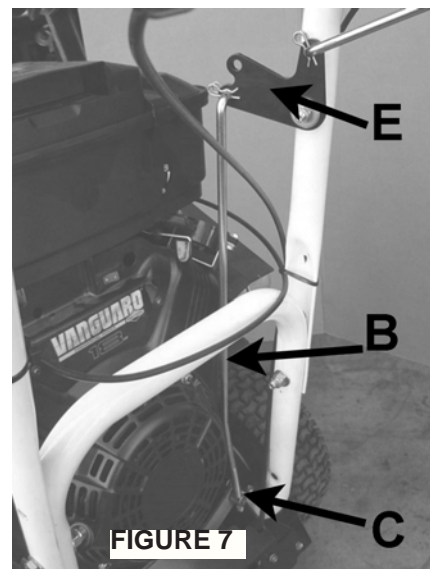

FIGURE 7

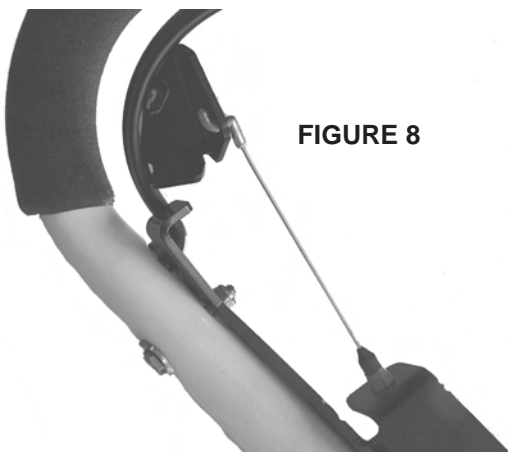

FIGURE 8

SWITCH (A)

Move to the "OFF" position to stop the engine. Move to the "ON" position before starting engine.

THROTTLE (B)

Controls engine speed and the amount of air being blown.



CHOKE (C)

Move to the "CHOKE" position to apply the choke. Move to the "RUN" position to remove the choke.

FUEL SHUT OFF (D)

Move to the "OFF" position to shut off the fuel whenever transporting the machine by trailer or truck or during storage. Move to the "ON" position before starting the engine.

REMOTE HORIZONTAL DEFLECTOR LEVER (E)

Move the lever forward to direct the flow of air down. Move the lever back to direct the flow of air up.

LOCKING KNOB (F)

Tighten the knob to lock the horizontal deflector in the desired position. Loosen to allow the deflector to be rotated with remote horizontal deflector lever.

VERTICAL DEFLECTOR (J)

Rotate the deflector to direct air discharge forward or to the side.

HORIZONTAL DEFLECTOR (H)

Directs air flow. Controlled by Remote Horizontal Deflector Lever E. May be locked in place with knob F.

SPEED / DIRECTION CONTROL LEVER (K)

Sets the speed and direction of the traction drive. Move forward from the neutral position for increasing forward speed. Move rearward from the neutral position for increasing reverse speed.

TRACTION CLUTCH BAIL (G)

Move the traction clutch bail towards the handle to engage the traction drive. Release the bail to disengage the traction drive.

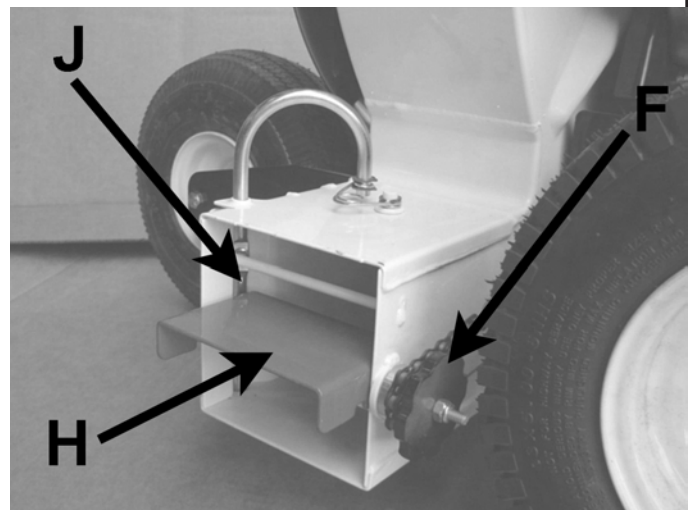
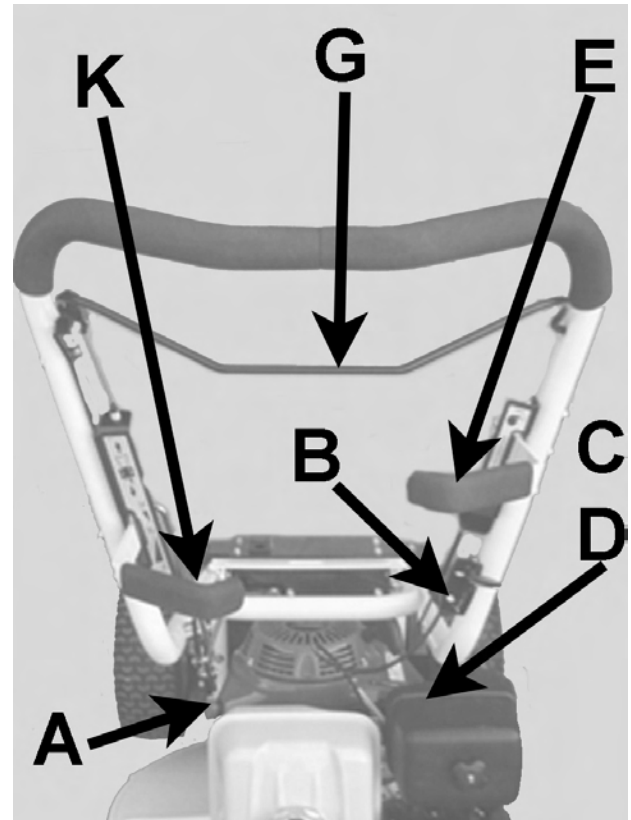

BEFORE STARTING THE ENGINE

1. Read the Operator Manual and Engine Manual. Become familiar with the controls, how each functions, and what it operates.
2. Check the engine oil level and add if necessary.
3. Fill the fuel tank with good quality, clean, unleaded regular gasoline (petrol). Use a funnel to avoid spilling.

OPERATING INSTRUCTIONS

Air flow can be directed to the side or front by the two-position vertical deflector. The front discharge position is used to remove debris from along walls, fences, etc. The side discharge position is used to form windrows or piles. The horizontal deflector directs air downward to "chisel" under wet, heavy leaves and litter. Air speed is regulated by the throttle setting.

To reduce windrowing or to blow over an obstacle, point deflector upward.

To avoid blowing in an area, close deflector and reduce throttle setting.

Slight changes in deflector position will have a big effect on air flow. Experiment until you find the best position for your needs.

When clearing a yard or parking lot, planning how to blow it off can greatly reduce the total clearing time.

To operate the machine, select the desired speed with the speed/direction lever. Gradually engage the clutch bail until the machine begins to move. Continue to move the bail until it contacts the handle.

To stop the machine's powered movement, release the bail.

Use the speed selector to change speeds.
-Do not "feather" or partially engage the clutch to slow speed. Doing so will rapidly wear the drive disc. Change the setting of the speed/direction lever to vary speed.

-The speed/direction lever may be moved while the clutch bail is engaged. However, it will operate more

easily if it is moved while the clutch bail is released, particularly if going from forward to reverse.

Curbs may be climbed by backing up the curb at an angle or by tipping the machine back and driving the front wheel over the curb. The back may then be lifted and the machine pushed forward onto the curb.

To stop the engine, move the throttle control to the slow position and switch the engine off.

Slow the engine when moving from work site to work site. This will save fuel and prevent inadvertently blowing debris where you don't want to.

NOTE: When transporting the machine by truck or trailer, close the fuel valve. This avoids the possibility of flooding should any dirt get under the carburetor float needle. Leaving the valve open can allow severe flooding which may ruin the engine by diluting the oil.

MAINTENANCE INSTRUCTIONS

Stop engine and remove the spark plug wire before performing any maintenance.

Keep blower air intake clear of debris for best performance.

Clear air discharge area of any debris accumulation. Ensure machine has been shut off and fan is no longer moving before clearing.

Keep all hardware tight.

Check oil level daily. Top off as needed.

Change engine oil after the first 5 hours of operation. Then change as recommended by the engine manufacturer.

1. Remove drain plug and drain oil while engine is warm.
2. Replace drain plug, remove fill plug and fill with new oil. See engine manual for oil specifications.
3. Start and run engine for 30 seconds. Stop engine.
4. Wait 30 seconds, then re-check oil level.
5. Top off if necessary. See engine manual for details.

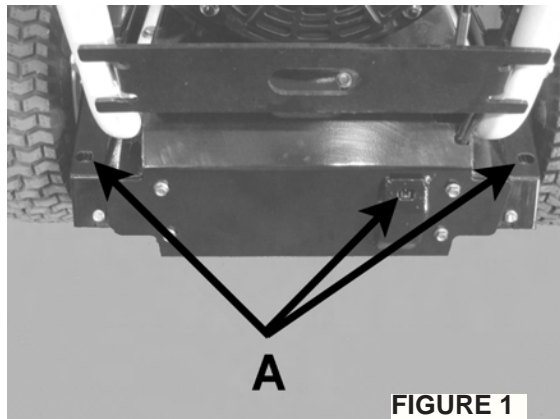

FIGURE 1

Lubricate chains every 40 hours or weekly, whichever comes first. Use a teflon containing chain lubricant such as bicycle chain lube that does not attract dirt. Bicycle chain lube is available at any bicycle shop or most places where bicycles are sold. Slots **A** are provided in the chain covers to allow chain lubrication. Keeping the chains lubricated will greatly extend the life of both the chains and the sprockets. (Figure 1)

Lubricate the hex shaft/trunnion assembly once a season or if moving the speed/direction lever becomes difficult. A teflon containing lubricant such as bicycle chain lube is recommended. To lubricate the hex shaft the bottom cover must be removed and the unit tipped up and to the right until it rests on the housing. The bottom cover is held by two nuts on the rear of the unit. (Figure 2)

Take care not to get any lubricant on either the drive or the driven disc. Any lubrication on these parts will cause slipping of the friction drive. Clean off any lubricant that gets on the drive or driven parts.

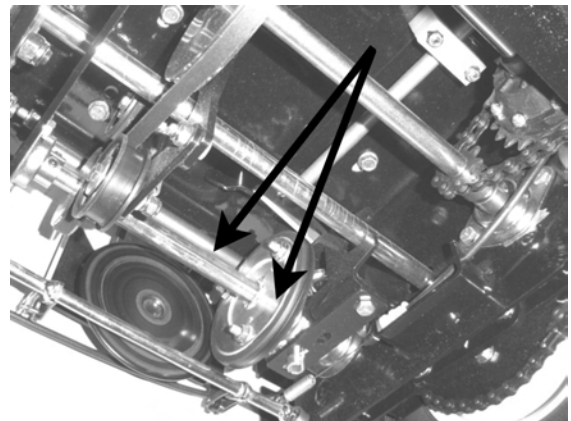

FIGURE 2

DEFLECTOR LEVER

If the horizontal deflector door during operation, tighten the deflector lever pivot bolt to increase the tension on the friction washers. just enough to keep the deflector in place. **DO NOT over tighten, the handle tube could crush.**

HORIZONTAL DEFLECTOR

Adjust the jam nuts on the cable fitting so the deflector door is completely closed when the deflector lever is moved all the way forward. (Figure 1)

DEFLECTOR CHAIN

The sprocket needs to be installed on the deflector as shown. The chain consists of 2 master links, 6 roller links, and 5 pin links. The middle pin link should be over the center tooth of the sprocket. (Figure 2)

If large amounts of adjustment are required, the chain can be moved one pitch on the sprocket to gain 1/2" of adjustment.

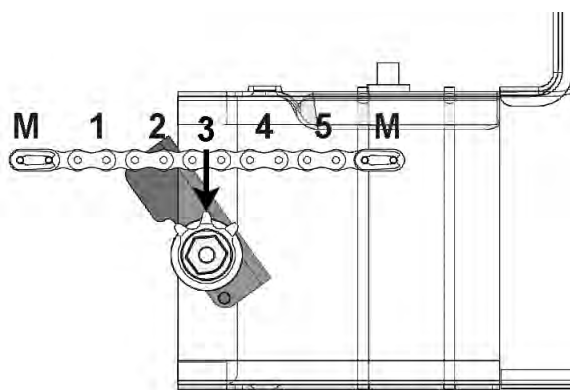
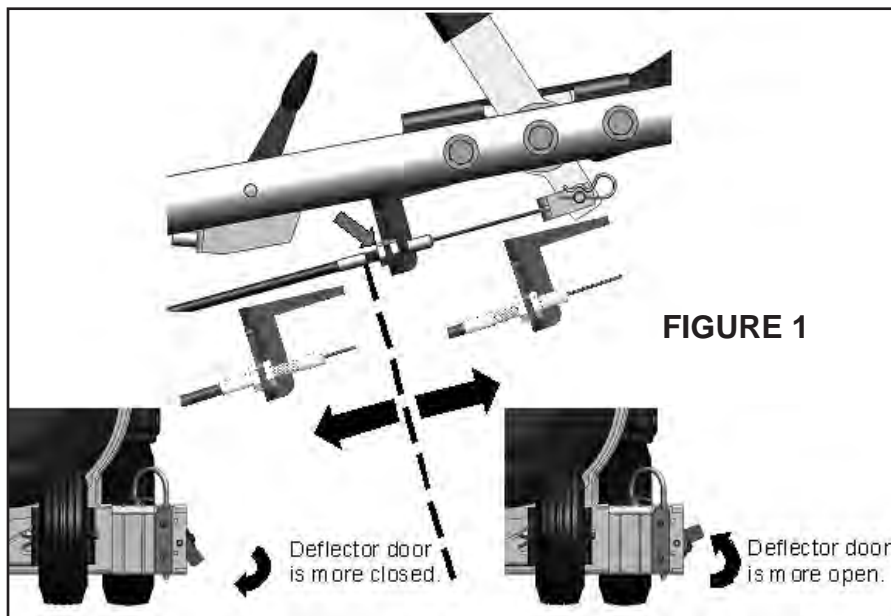

SPEED / DIRECTION CONTROL LEVER

If the speed/direction control lever moves during operations, tighten the pivot bolt just enough to increase the tension on the friction washers to keep in place. **DO NOT over tighten, the handle could crush.**

VERTICAL SPEED CONTROL ROD

Disconnect the speed control rod **B** from the pivot plate. Move the speed control lever all the way forward. Pull up on the rod **B** to move the linkage against the forward stop. Turn the rod in or out of the swivel **C** until it just goes into the pivot plate **E**. (Use the lower pivot plate hole for the upper handle position.) Secure the rod to the pivot plate **E** with two hairpin cotters. (Figure 3)

HANDLE HEIGHT

Two handle height positions are provided. To move from one to the other, disconnect the speed/direction rod, then remove the four handle bolts. Reposition the handle to the other set of holes and reinstall the handle bolts. Adjust the vertical speed control rod to the new positions. Reconnect the speed/direction rod. (Figure 4)

WHEEL CHAIN TENSION

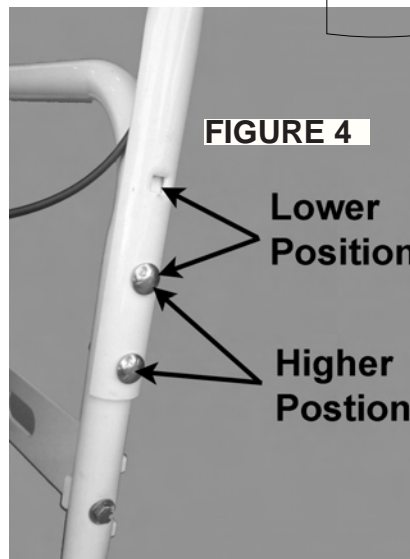
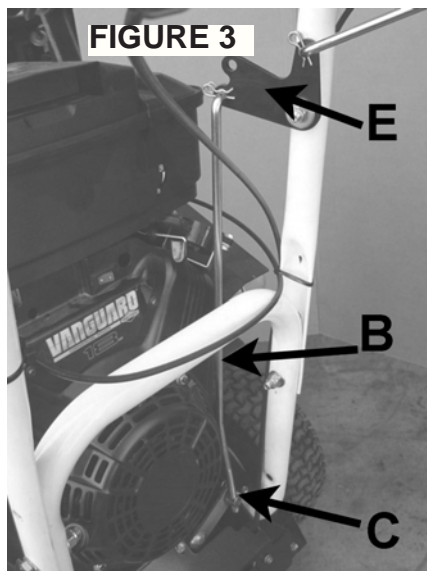

If the wheel drive chain becomes too slack, the tension needs to be increased or it can run off the sprockets.

To adjust the tension, tip the machine to the right until it rests on the blower housing. Then loosen the nuts **A** on the carriage bolts securing the chain adjuster brackets on each side. Leave the center pivot bolt **B** tight. Once the carriage bolts are loose, support the rear of the machine with the wheels off the ground and move the adjuster brackets until the chain has 1/16" to 1/8" droop on the slack side with the other side tight. Both adjusters should be in about the same position. Tighten the nuts on the carriage bolts. If there is no more adjustment or the 2 sides are not in about the same position, replace the wheel chains. See wheel chain replacement. (Figure 5)

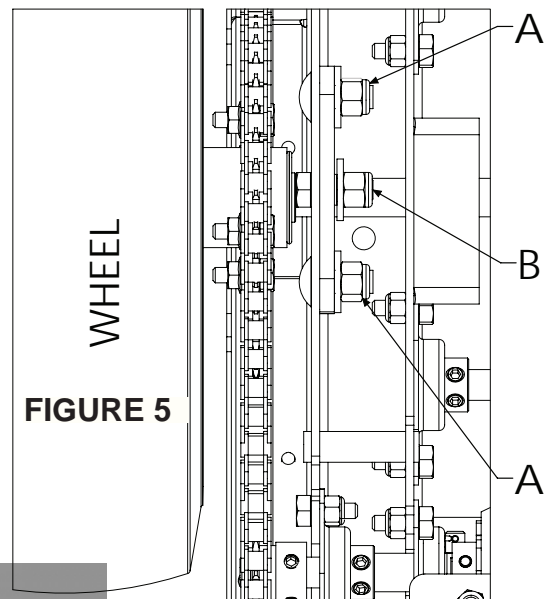

ENGINE- DRIVE DISC BELT

1. Remove front cover and fan from blower.
2. Move the deflector control lever all the way back. Disconnect the deflector return spring from the housing.
3. Remove blower housing from engine and engine deck.
4. Disconnect master links connecting drive disk mount to clutch shaft.
5. Remove nut holding drive disc to pivot pulley.
6. Remove the old belt. Check the idler pulley and drive disks. If there is any question about their condition, replace them.
7. Route the new belt around the drive disk pulley, engine pulley and the idler pulley as shown. (Figure 1)
8. Reassemble in reverse order.
9. Use blue thread locking compound when installing the housing to engine face bolts. Torque to 22-28 ft. lbs.
10. Use red thread locking compound when installing the fan bolt.

Torque: 3/8-24 torque 30-50 ft. lbs.
7/16-20 torque 50-90 ft. lbs.

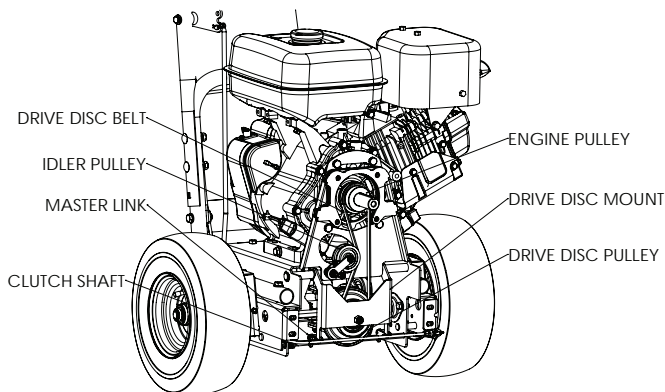

Figure 1

1ST STAGE REDUCTION BELT

Figure 2

1. Remove the wheel chain covers and wheel chains.
2. Remove the hex shaft per the Driven Disc Replacement section. If the driven disc is worn replace it.
3. Remove the drive wheels and axle.
4. Use the master link to disconnect the differential chain. Remove the differential chain.
5. Loosen and back off the setscrews **A** on the bearing adaptor on the sprocket end of the intermediate shaft.
6. Remove the mounting bolts **B** for the bearing on the pulley end of the intermediate shaft.
7. Slide the shaft **C** into the sprocket end bearing **D**. Work the old belt off between the pulley end bearing and the engine deck.
8. Inspect the chain, sprockets, and bearings. Replace worn parts.
9. Install the new belt between the bearing and engine deck.
10. Reinstall in reverse order. Be sure to put the belt around the hex shaft and axle before installing them. Check the installation for alignment of the pulleys. Install the axle between the trunnion anti-rotation tabs **E**.

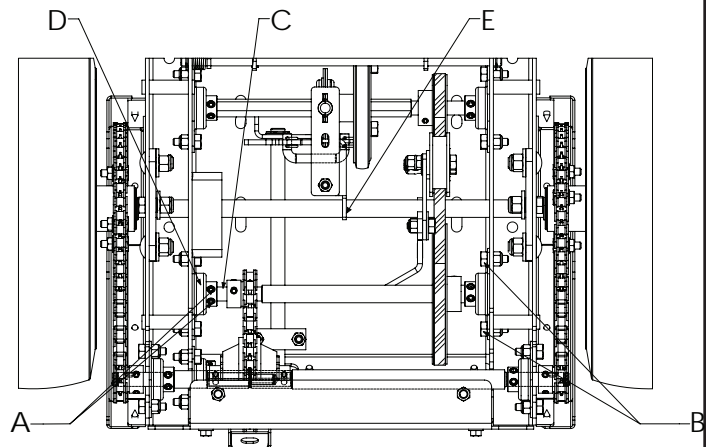

Figure 2

DIFFERENTIAL CHAIN

If this chain is worn or becomes too slack it must be replaced. There is no adjustment.

1. Remove the bottom cover.
2. Find and remove the master link.
3. Remove the old chain. Check the sprockets for wear. Replace if visibly worn.
4. Install the new chain with a new master link. Lubricate with teflon based chain lubricant, such as bicycle chain lube.
5. Reinstall the bottom cover.

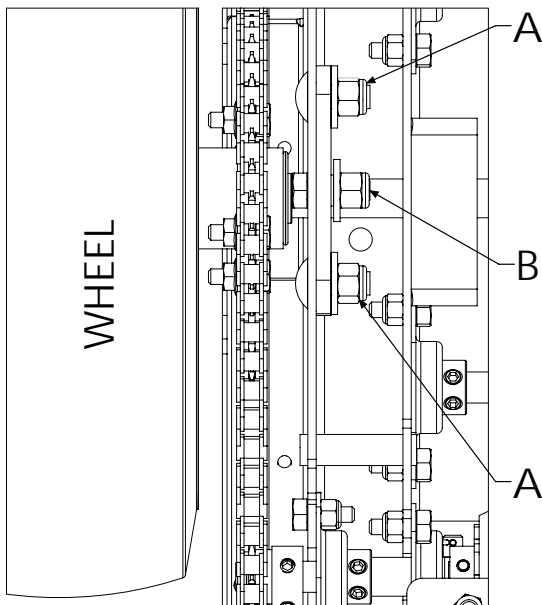

Figure 3

WHEEL CHAINS

If there is no more adjustment, the wheel chains need to be replaced. (Figure 3)

NOTE: Wheel chains need to be replaced in pairs to keep the adjustment even from one side to the other.

1. Remove the chain covers. Find and remove the master links and remove old chains.
2. Check sprockets for wear. Replace if visibly worn.
3. Tip the machine to the right until it rests on the blower housing.
4. Loosen the nuts **A** on the carriage bolts securing the chain adjuster brackets on each side. Leave the center pivot bolt **B** tight.
5. Once the carriage bolts are loose, set the machine back down and install the new chains.
6. Check and ensure the differential output sprockets and wheel sprockets are aligned. If necessary, use spacer washers to eliminate as much axial play as possible of the wheel on the axle.
7. Support the rear of the machine with the wheels off the ground and move the adjuster brackets until the chain has 1/16" to 1/8" droop on the slack side with the other side tight. Both adjusters should be in about the same position.
8. Tighten the nuts **A** on the carriage bolts.
9. Lubricate the chains with bicycle chain lubricant.
10. Reinstall the chain covers.

DRIVEN DISC REPLACEMENT

Figure 4

1. Disconnect the clutch cable at the clutch bail. If necessary the bail may be squeezed together to remove it from the handle to get enough slack. Move the speed control lever to neutral.
2. Drain the oil and fuel so the machine may be tipped.
3. Remove the front wheel bracket and inlet cover. Tip the machine forward onto the fan housing to gain access to the bottom side.
4. Remove bottom cover.
5. Remove the outermost hairpin cotter **A** on each end of the trunnion link rod **B**. Remove the trunnion link rod.
6. Loosen and back off the setscrews **C** on both bearing adaptors on the hex shaft.
7. Remove the bolts **D** holding the bearings on each end of the hex shaft to the engine deck.
8. Slide the pulley end bearing **E** toward the pulley to gain clearance to tip the shaft out of the engine deck. Remove the shaft assembly from the engine deck.
9. Slide the bearing **F** off the trunnion end of the shaft and remove the trunnion.
10. Replace the driven disc.
11. Reinstall in the reverse order. Be sure to put the belt around the hex shaft. Check the installation for pulley alignment with a straight edge.
12. Refill the engine with oil.

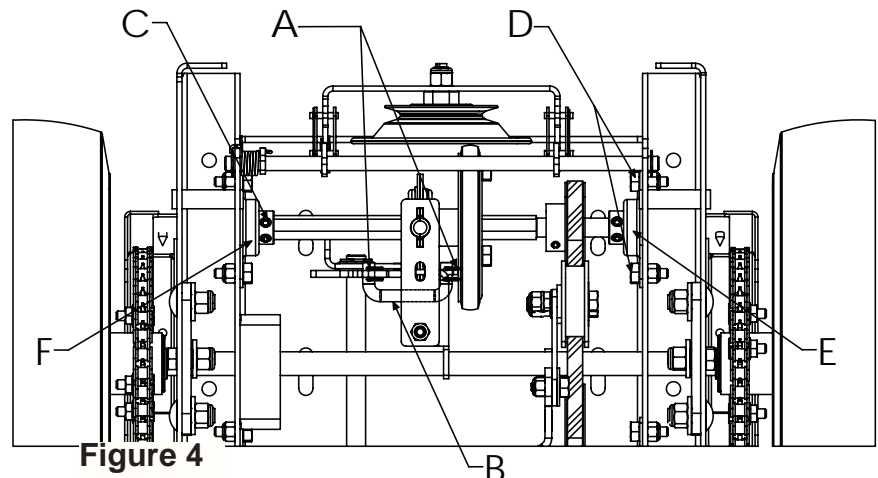

Figure 4

DIFFERENTIAL REPLACEMENT

1. If the shafts are removed or the differential needs to be replaced, the equivalent of one or two pumps of Bentonite (waterproof) grease must be put in the space where the shafts come together.
2. Install the shaft with the hollow end, then put the grease in the differential cavity and install the second shaft. (Figure 5)

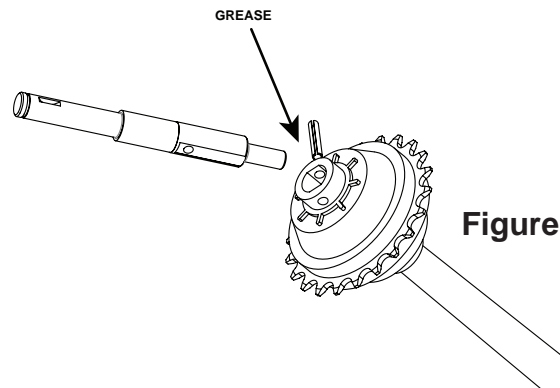

Figure 5

LITTLE WONDER BLOWER

STORAGE / TORQUE SPECIFICATIONS

STORAGE

To prevent possible explosion or ignition of vaporized fuel, do not store equipment with fuel in tank or carburetor in an enclosure with open flame (for example, a furnace or water heater pilot).

Before the equipment is put into storage for any period exceeding 30 days.

1. Drain all fuel from the fuel tank and fuel lines.
2. Start the engine and run until all the fuel is used from the carburetor float bowl and the engine stops.
3. While the engine is still warm, drain the crankcase oil and replace with the proper weight oil corresponding to the season the equipment will be next used.
4. Remove the spark plug and squirt a small amount of engine oil into the cylinder. Slowly pull the starter a few times to distribute oil in the cylinder and reinstall the spark plug.
5. Top off if necessary. See engine manual for details.

To put the equipment into service after an extended period of storage.

1. Check for loose parts and tighten if necessary.
2. Fill the fuel tank and then check the engine oil level.
3. Start the engine and check for fuel leaks. Repair any leaks before operating the unit.

TORQUE SPECIFICATIONS

Location	Description	P/N	Min. Torque Ft-lbs (In-lbs)	Max. Torque Ft-lbs (In-lbs)
Housing to engine face	BLT-W LF 5/16-24 x 1-3/8	910517	22	28
Engine to deck	BLT 5/16-18 X 1-1/2	64262-009	19	25
Fan to Crankshaft	BLT-HEX 7/16-20 x 1-3/4 GR8 (USED ON 9270 MODELS)	64123-253	50	90
	BLT-HEX 3/8-24X1-3/4 GR8 (USED ON 9390 AND 9400 MODELS)	64123-127	30	50
	BLT-HEX 3/8-24 X 2.5 GR 8 (USED ON 9570 MODELS)	64123-267	30	50

PARTS SECTION

LITTLE WONDER BLOWER

INTAKE GUARD ASSY

FIGURE 1

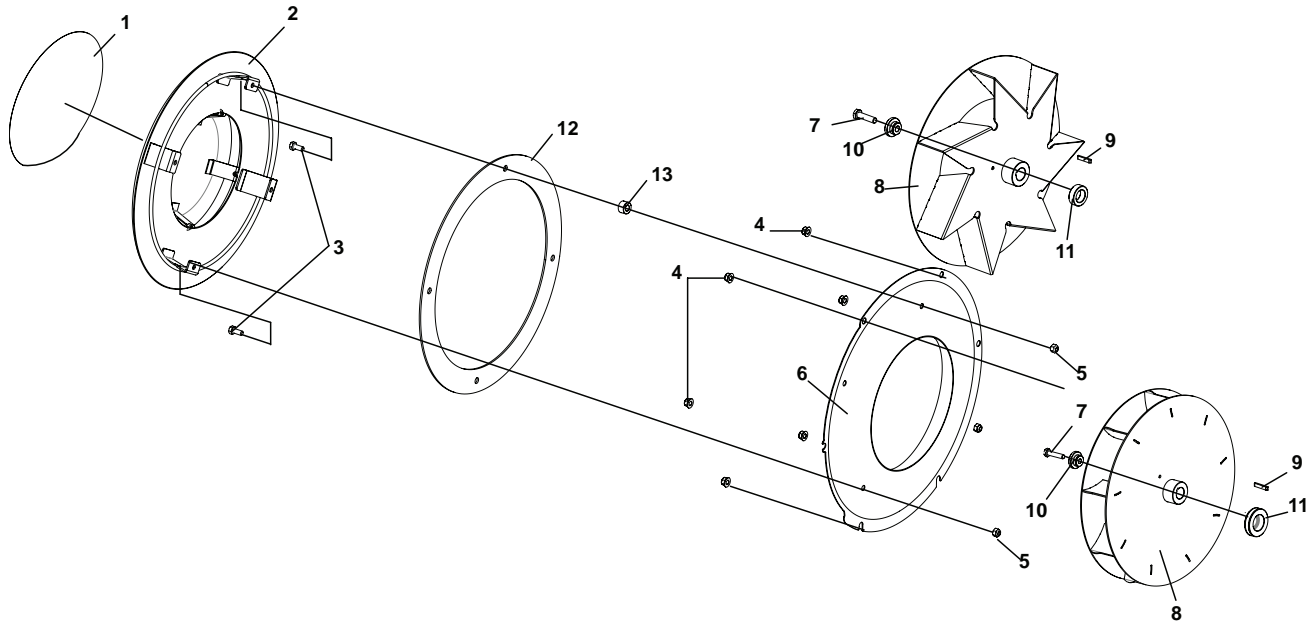

ITEM	PART NO.	DESCRIPTION	QTY	ITEM	PART NO.	DESCRIPTION	QTY
1	4166183	LABEL-INTAKE GUARD	1	10	4163427	PLUG-FAN 7/16 X 1 (USED ON 9270 MODELS)	1
2	4165218.7	ASSY-GUARD INTAKE	1	4163424	PLUG-FAN 3/8 X 1.0 (USED ON 9390 AND 9400 MODELS)		
3	64123-54	BLT-HEX 5/16-18X.75	4	4166437	PLUG-FAN 18 VAN (USED ON 9570 MODELS)		
	64123-69	BLT-5/16-18 X 1 1/2 (USED ON 9570 MODEL ONLY)					
4	64268-02	NUT-FL NYLON LOCK 5/16-18	6	11	4165169	SPACER-FAN .53 (USED ON 9270, 9390, & 9400 MODELS)	1
5	64229-02	NUT 5/16-18	4	4165170	SPACER-FAN 1.24 (USED ON 9570 MODEL)		
6	4165926.10	INTAKE PANEL-CENTER	1	12	4166997	RING-INLET OFFSET (USED ON 9570 MODEL ONLY)	1
7	64123-253	BLT-HEX 7/16-20 x 1-3/4 GR8 (USED ON 9270 MODELS)	1	13	33030-09	BUSHING-.72 X .875 (USED ON 9570 MODEL ONLY)	4
	64123-127	BLT-HEX 3/8-24X1-3/4 GR8 (USED ON 9390 AND 9400 MODELS)					
	64123-267	BLT-HEX 3/8-24 X 2.5 GR 8 (USED ON 9570 MODELS)					
8	4166730	WLDMT-FAN 7 BLADE 2.75 (USED ON 9270 MODELS)	1				
	4166731	WLDMT-FAN 9 BL (USED ON 9390 AND 9400 MODELS)					
	4166992	WLDMT-FAN, 9BL 3.50 (USED ON 9570 MODELS)					
9	64164-13	KEY 1/4 X 2 SQ	1				
	64164-40	KEY 1/4 X 1-3/4 SQ (USED ON 9570 MODELS)					

HANDLE ASSY

FIGURE 2

LITTLE WONDER BLOWER

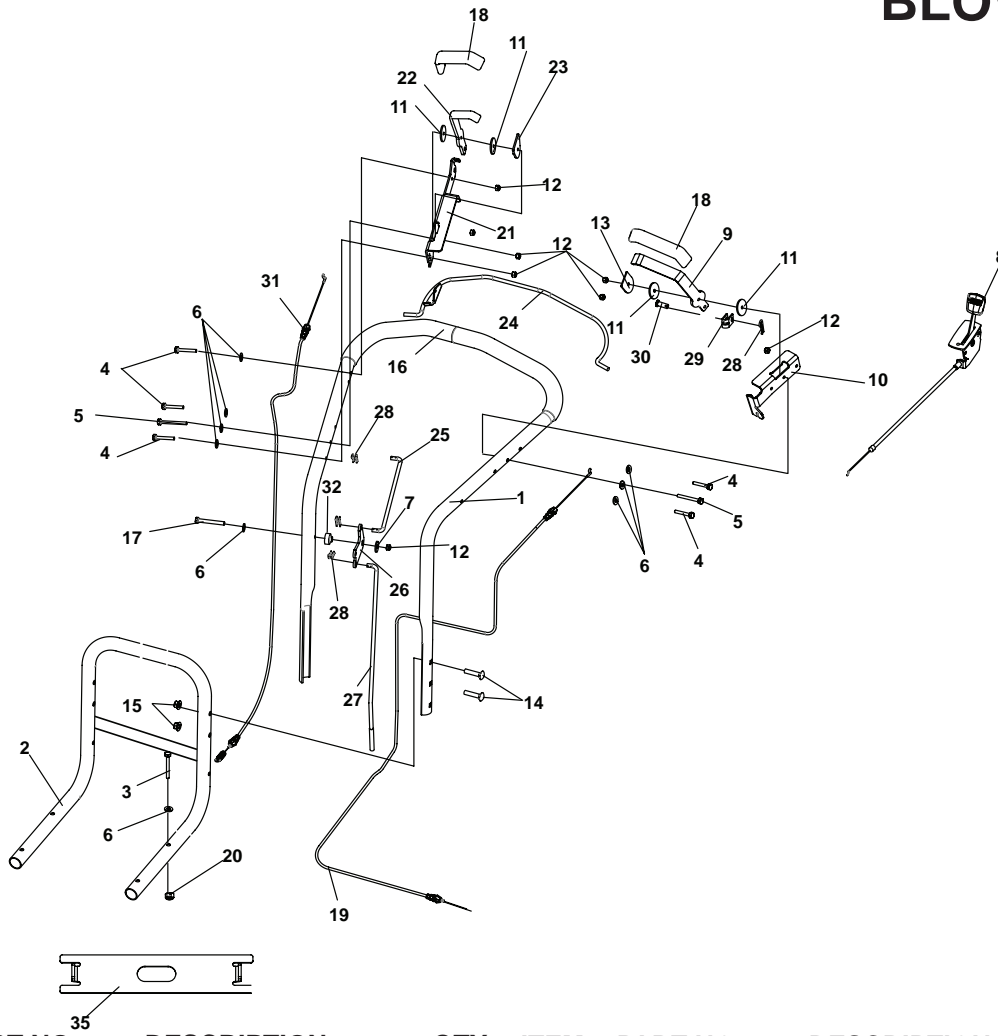

ITEM	PART NO.	DESCRIPTION	QTY	ITEM	PART NO.	DESCRIPTION	QTY
1	4166779	S-HANDLEUPPER W/ GRIP	1	16	4164632	GRIP-1-1/4 X 14	2
2	4167557.10	HANDLE-BLOWER LOWER (USED ON 9270,9390, 9400 MODELS)	1	17	64123-12	BLT-HEX 5/16-18X2-1/2	1
	4164591.10	HANDLE-BLOWER 9570 MODEL (USED ON 9570 MODEL)		18	4165987	GRIP-1/4X1X5	2
3	64123-61	BLT-HEX 5/16-18 X 1-3/4 (QTY 6 ON 9570 MODEL)	4	19	4166617	CABLE-PRE DEFLECTOR, SP	1
4	64123-283	BLT-HEX 1/4-20 X 1-3/4	5	20	64229-02	NUT-NYLON LOCK 5/16-18	4
5	64123-98	BLT-HEX 1/4-20X2-1/2	2	21	4166817	S-BRKT,SPEED CONTROL	1
6	64163-55	WASHER-.531 x 2.00 x .125 (QTY 14 ON 9570 MODEL)	12	22	4166819	S-LEVER-SP,RIGHT	1
7	64163-29	WASHER-21/64 X 1 X 11GA	1	23	4166330	WASHER-ANTIROTATION	1
8	4166170-01	CABLE-THROTTLE HONDA (USED ON HONDA ENGINES)	1	24	4166331.7	WLDMT-TRACTION DRIVE	1
	4166170-02	CABLE-THROTTLE (USED ON SUBARU ENGINES)	1	25	4166263	ROD-SPEED CONTROL HOR	1
	4166170-03	CABLE-THROTTLE (USED ON VANGUARD ENGINES)	1	26	4165084.7	PLATE-PIVOT, SPEED CONTROL	1
10	4166780	S-BRACKET,LEVER MOUNTING	1	27	4166262	ROD-SPEED CONTROL VERT	1
11	4165854	WASHER-UHMW PE	4	28	64168-2	COTTER-HAIRPIN .08 X 1.19	7
12	64229-01	NUT-NYLON LOCK 1/4-20 (QTY 10 ON 9570 MODEL)	8	29	4166457	CLEVIS-CABLE	1
13	4165855	WASHER-ANTIROTATION	1	30	64188-65	PIN-CLEVIS, 1/4 X .62	1
14	64018-5	BLT-CRG 3/8-16X1-3/4	4	31	4165154	CABLE-BLOWER CLUTCH	1
15	64268-03	NUT-FL NYLON LOCK 3/8-16	4	32	4166808	BUSHING-SPACER	1
				33*	4166816	LABEL-SPEED CONTROL	1
				34*	4165913	LABEL-DEFLECTOR	1
				35	4165895.10	BRACE-LOWER HANDLE (USED ON 9570 MODEL ONLY)	1

*NOT ILLUSTRATED

TRANSMISSION ASSY

LITTLE WONDER BLOWER

FIGURE 4

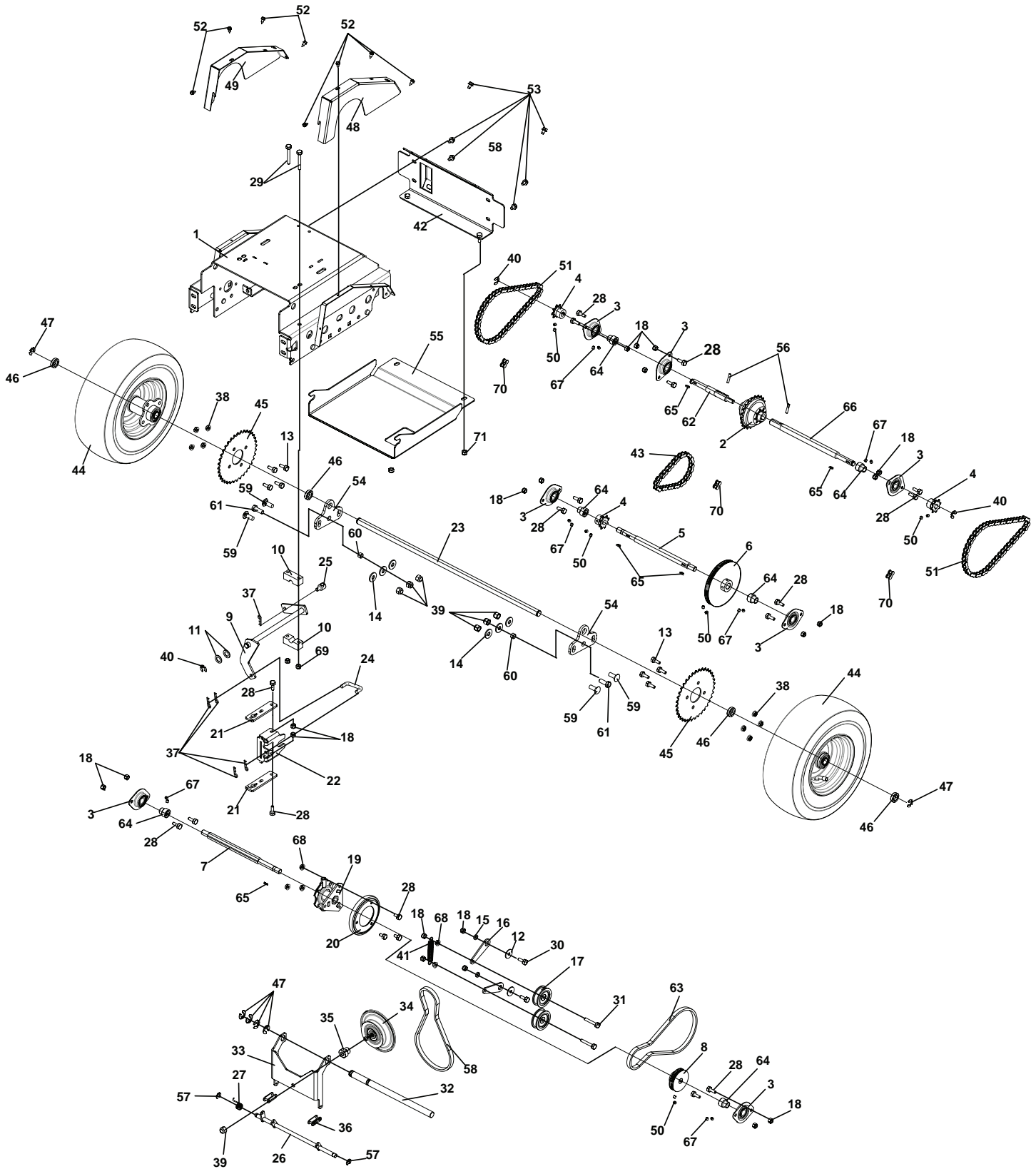

LITTLE WONDER BLOWER

TRANSMISSION ASSEMBLY

FIGURE 4

ITEM	PART NO.	DESCRIPTION	QTY	ITEM	PART NO.	DESCRIPTION	QTY
1	4166271.7	WLDMT-DECK,SP	1	37	64168-2	COTTER-HAIRPIN .08 X 1.19	5
2	4165055	GT DIFFERENTIAL D16	1	38	64141-6	NUT-WLF 5/16-18	8
3	4130975	BRG-BALL FLUSH MT TWO BLT 5/8	7	39	64229-03	NUT-NYLON LOCK 3/8-16	7
4	4165061	SPROCKET-DRIVE #43-8	3	40	64144-34	SNAP RING .50	1
5	4165092	SHAFT-INTERMEDIATE	1	41	4165149	SPRING-EXTENSION	1
6	4165100	PULLEY-V-RIBBED BELT 4.875	1	42	4166272.7	WLDMT-COVER,REAR SP	1
7	4165093	SHAFT-HEX	1	43	4165190	CHAIN-#43 ROLLER 27 PITCH	1
8	4165099	PULLEY-V-RIBBED BELT 2.25	1	44	4166380	WHEEL ASM-4.10/3.50X6 FLANGE	2
9	4166316	WLDMT-CONTROL,SPEED	1	45	4165060	SPROCKET-WHEEL #43-36	2
10	4166231	BLOCK-BEARING	2	46	4164192-01	SPACER-PWDR MTL .635X1.0X.25	4
11	64163-102	WASHER-MACH 1/2 X 7/8 X .045	2	47	64144-36	SNAP RING 0.625	6
12	64163-34	WASHER-1/4X1 x 11GA	2	48	4165094.7	GUARD-CHAIN,LEFT	1
13	64139-08	BLT-WLF 5/16-18X3/4	8	49	4165095.7	GUARD-CHAIN,RIGHT	1
14	64163-31	WASHER-25/64 X 1 X 11GA	6	50	64044-1	SCREW-SET 1/4-20 X 1/4	10
15	4165281	SPACER-0.259 X 0.500 X 0.145	2	51	4165191	CHAIN-#43 ROLLER 47 PITCH	2
16	4165076.7	PLATE-IDLER ARM,DBL	2	52	64152-56	SCREW-HS STAP #12X1/2	8
17	4165119	IDLER-1.875 OD	2	53	64152-23	SCREW-SP 1/4-20X3/8	6
18	64229-01	NUT-NYLON LOCK 1/4-20	20	54	4166697.7	BRACKET-CHAIN ADJUST	2
19	4165112	TRUNNION	1	55	4166755.7	GUARD-ENGINE DECK,SP	1
20	4165111	WHEEL-FRICTION	1	56	64245-04	PIN-ROLL METRIC 5X24	2
21	4166136.7	PLATE-TRUNNION MOUNTING	2	57	64144-30	SNAP RING.375	2
22	4166164.7	BRKT-TRUNNION	1	58	4165046	BELT-ENGINE DRIVE DISC	1
23	4165108	AXLE-BLOWER, SP	1	59	64018-3	BLT-CRG 3/8-16X1	4
24	4166026	LINK-TRUNNION	1	60	521679	BUSHING	2
25	33103	SWIVEL	1	61	64123-50	BLT-HEX 3/8-16X1	2
26	4165079	SHAFT-CLUTCHING	1	62	4165057	SHAFT-DIFFERENTIAL, SHORT	1
27	4165150	SPRING-TORSION, CLUTCH	1	63	4165047	BELT-V RIBBED	1
28	64123-89	BLT-HEX 1/4-20X3/4	19	64	4166622	ADAPTOR-BEARING	6
29	64123-60	BLT-HEX 1/4-20X2	2	65	64164-05	KEY 1/8 X 1/2 #3 WOODRUFF	5
30	64123-114	BLT-HEX 1/4-20X1	2	66	4165056	SHAFT-DIFFERENTIAL, LONG	1
31	64123-07	BLT-HEX 1/4-20X1-1/2	2	67	64044-13	SCREW-SET 1/4-28X1/4	12
32	4165107	SHAFT-HINGE	1	68	64141-2	NUT-1/4-20 WLF	5
33	4165067.7	MOUNT-DRIVE DISK	1	69	64268-01	NUT-FL NYLON LOCK 1/4-20	2
34	4165117	DISC-DRIVE	1	70	4165192	LINK-MASTER #3	3
35	4165118	SPACER-DISC DRIVE	1	71	64268-02	NUT-FL NYLON LOCK 5/16-18	2
36	4165989	LINK-MASTER #2040	2				



5 YEAR LIMITED SERVICE AND WARRANTY POLICY FOR LITTLE WONDER BLOWERS

All Little Wonder Blowers are warranted against defects in material and workmanship for a period of five (5) years from the date of purchase, under the following terms and conditions.

LITTLE WONDER will repair or replace, at its option, any part or parts of the product found to be defective in material or workmanship during the warranty period. Warranty repairs and replacements will be made without charge for parts or labor. All parts replaced under warranty will be considered as part of the original product, and any warranty on the replaced parts will expire coincident with the original product warranty. If you think your LITTLE WONDER BLOWER is defective in material or workmanship, you must return it to a registered dealer with a valid sales receipt or to our factory at 1028 Street Rd., Southampton, PA 18966. Transportation charges to ship your product to us or a registered dealer must be borne by you.

Engines for all gasoline powered products are warranted separately by the engine manufacturer. Therefore, there are no warranties made, expressed or implied, for engines for gasoline powered products by LITTLE WONDER.

LITTLE WONDER assumes no responsibility in the event that the product was not assembled or used in compliance with any assembly, care, safety or operating instructions contained in the Owner's Manual or information accompanying the product. This limited warranty does not cover damages or defects due to normal wear and tear, lack of reasonable and proper maintenance, failure to follow operating instructions or Owner's Manual, misuse, lack of proper storage or accidents, nor does it cover routine maintenance parts and service. This limited warranty does not cover any defects due to repairs or alterations made to the product made by anyone other than LITTLE WONDER or its registered dealers.

You must maintain your LITTLE WONDER Blower by following the maintenance procedures described in the owner's manual. Such routine maintenance, whether performed by you or a registered dealer, is at your expense.

LITTLE WONDER MAKES NO EXPRESS OR IMPLIED WARRANTIES REPRESENTATIONS OR PROMISES EXCEPT THOSE CONTAINED HEREIN. THERE ARE NO OTHER WARRANTIES, INCLUDING WARRANTIES OF MERCHANTABILITY AND FITNESS FOR A PARTICULAR PURPOSE. ALL WARRANTIES OTHER THAN THE EXPRESS WARRANTY SET FORTH ABOVE ARE SPECIFICALLY DISCLAIMED. THE DURATION OF ANY IMPLIED WARRANTY, INCLUDING MERCHANTABILITY AND FITNESS FOR A PARTICULAR PURPOSE, IS LIMITED TO THE DURATION OF THIS WRITTEN LIMITED WARRANTY. LITTLE WONDER DISCLAIMS ALL LIABILITY FOR INDIRECT, INCIDENTAL AND/OR CONSEQUENTIAL DAMAGES IN CONNECTION WITH THE USE OF THE LITTLE WONDER BLOWER PRODUCTS COVERED BY THIS WARRANTY. SOME STATES DO NOT ALLOW LIMITATIONS ON HOW LONG AN IMPLIED WARRANTY LASTS AND/OR DO NOT ALLOW THE EXCLUSION OR LIMITATION OF INCIDENTAL OR CONSEQUENTIAL DAMAGES, SO THAT ABOVE LIMITATIONS AND EXCLUSIONS MAY NOT APPLY TO YOU. THIS WARRANTY GIVES YOU SPECIFIC LEGAL RIGHTS, AND YOU MAY ALSO HAVE OTHER RIGHTS WHICH VARY FROM STATE TO STATE.

LITTLE WONDER®

SCHILLER GROUNDS CARE, INC.

1028 STREET ROAD, P.O. BOX 38

SOUTHAMPTON, PA 18966

PHONE 877-596-6337 • FAX 215-357-8045

www.littlewonder.com