

MBR BLOWER CABINET

INSTALLATION INSTRUCTIONS

THIS PRODUCT CONTAINS ELECTRONIC COMPONENTS WHICH REQUIRE A DEFINITE GROUND. PROVISIONS ARE MADE FOR CONNECTION OF THE GROUND. A DEDICATED GROUND FROM THE MAIN POWER SUPPLY OR AN EARTH GROUND MUST BE PROVIDED.

INTRODUCTION

This booklet contains the installation and operating instructions for your modular blower cabinet. All warnings and precautions within this booklet must be observed. Improper installation can result in unsatisfactory operation or dangerous conditions and void the warranty. Read this booklet and any instructions packaged with accessories prior to installation. Give this booklet to the user and explain its provisions. The user should retain this booklet for future reference.

CHECKING PRODUCT RECEIVED

Upon receiving the unit, inspect it for damage from shipment. Claims for damage, either shipping or concealed, should be filed immediately with the shipping company. Check the unit model number, specifications, electrical characteristics and accessories to determine if they are correct. In the event an incorrect unit is shipped, it must be returned to the supplier and must NOT be installed. The manufacturer assumes no responsibility for installation of incorrectly shipped units.

REPLACEMENT PARTS

ORDERING PARTS

When reporting shortages or damages, or ordering repair parts, give the complete unit model and serial numbers as stamped on the unit's nameplate.

Replacement parts for this appliance are available through your contractor or local distributor. For the location of your nearest distributor, consult the white business pages, the yellow page section of the local telephone book or contact:

CONSUMER AFFAIRS
GOODMAN MANUFACTURING COMPANY, L.P.
7401 SECURITY WAY
HOUSTON, TEXAS 77040
(877) 254-4729

IMPORTANT SAFETY INSTRUCTIONS

RECOGNIZE SAFETY SYMBOLS, WORDS, AND LABELS

The following symbols and labels are used throughout this manual to indicate immediate or potential hazards. It is the owner's responsibility to read and comply with all safety information and instructions accompanying these symbols. Failure to heed safety information increases the risk of property damage, product damage, personal injury or death.

WARNING

HIGH VOLTAGE!

Disconnect ALL power before servicing. Multiple power sources may be present. Failure to do so may cause property damage, personal injury or death.



WARNING

Installation and repair of this unit should be performed **ONLY** by individuals meeting (at a minimum) the requirements of an "entry level technician" as specified by the Air Conditioning, Heating, and Refrigeration Institute (AHRI). Attempting to install or repair this unit without such background may result in product damage, personal injury or death.

 **DANGER**
PELIGRO



CARBON MONOXIDE POISONING HAZARD

Special Warning for Installation of Furnace or Air Handling Units in Enclosed Areas such as Garages, Utility Rooms or Parking Areas

Carbon monoxide producing devices (such as an automobile, space heater, gas water heater, etc.) should not be operated in enclosed areas such as unventilated garages, utility rooms or parking areas because of the danger of carbon monoxide (CO) poisoning resulting from the exhaust emissions. If a furnace or air handler is installed in an enclosed area such as a garage, utility room or parking area and a carbon monoxide producing device is operated therein, there must be adequate, direct outside ventilation.

This ventilation is necessary to avoid the danger of CO poisoning which can occur if a carbon monoxide producing device continues to operate in the enclosed area. Carbon monoxide emissions can be (re)circulated throughout the structure if the furnace or air handler is operating in any mode.

CO can cause serious illness including permanent brain damage or death.

B10259-216



Contents

INTRODUCTION	1
CHECKING PRODUCT RECEIVED	1
REPLACEMENT PARTS	1
ORDERING PARTS	1
IMPORTANT SAFETY INSTRUCTIONS.....	1
RECOGNIZE SAFETY SYMBOLS, WORDS, AND LABELS	1
GENERAL INFORMATION	3
CLEARANCES AND ACCESSIBILITY	3
INSULATION	3
INSTALLATION INSTRUCTIONS.....	3
BLOWER WITH CASD EVAPORATOR COIL INSTALLATION	3
UPFLOW INSTALLATION	3
COUNTERFLOW INSTALLATION	3
HORIZONTAL INSTALLATION	4
ELECTRICAL CONNECTIONS	4
HIGH VOLTAGE WIRING	4
LOW VOLTAGE WIRING	5
MISCELLANEOUS ELECTRICAL	5
THERMOSTAT CONNECTIONS	5
WIRING DIAGRAMS	6

GENERAL INFORMATION

The MBR Blower Cabinets are used in combination with a cased evaporator coil. This combination of blower and coil functions as the indoor part of a split air-conditioning system, and may be matched with a remote condensing or heat pump unit. The blower cabinet can also function as an electric furnace when used with an electric heater.

NOTE: The electric heating elements for electric furnace installation are not shipped with the cabinet and are field-installed. Systems should be properly sized by heat gain and loss calculations made according to methods of the Air Conditioning Contractors Association (ACCA) or equivalent. It is the contractor's responsibility to ensure the system has adequate capacity to heat or cool the conditioned space.

CLEARANCES AND ACCESSIBILITY

The unit can be positioned for upflow, counterflow, horizontal right or horizontal left operation. Zero clearance is allowed on all sides for combustible materials. Thirty-six inches should be allotted on the door side for maintenance and service.

To reduce risk of rusting, do not install the unit blower directly on the ground or on a floor that is likely to be wet. In such environments, the unit must be elevated by use of a sturdy, nonporous material.

INSULATION

To ensure efficient operation, review the following precautions.

- If the unit is located in an area with high ambient temperature and/or high humidity, the air handler may be subject to nuisance sweating of the casing. On these installations, a wrap of 2" fiberglass insulation with a vapor barrier is recommended.
- The factory recommends insulating the duct running through any unconditioned spaces.

To reduce operating sound and vibration transmission use flexible canvas duct connections at the cabinet.

INSTALLATION INSTRUCTIONS

BLOWER WITH CASED EVAPORATOR COIL INSTALLATION

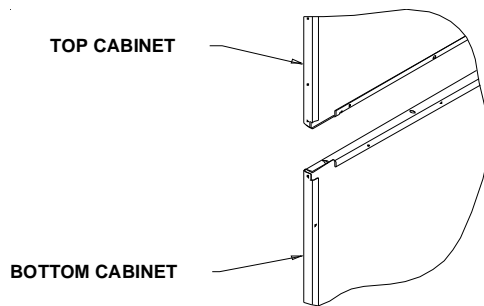

Figure 1

Secure the coil and blower together with the two connector plates and screws supplied in the blower bag assembly. Use one connector plate and six screws on each side of the unit.

If accessory electric heat is to be added, install now per the instructions shipped with the heater kit.

UPFLOW INSTALLATION

For upflow installations, the blower cabinet must sit on top of the coil cabinet (Figure 2). **NOTE:** All panels should be in place before installing the cabinet.

1. Place the blower and coil cabinet assembly upright on the return duct or duct opening. Ensure that there is ample support for the cabinet assembly and all attached ductwork.
2. Connect refrigerant and condensate drain connections per the evaporator coil installation instructions. Ensure refrigerant and drain lines do not interfere with service access to the unit.
3. Attach supply ductwork. Seal connections between unit and ductwork as required to reduce/eliminate air leakage.
4. Make electrical connections as specified in "Electrical" section of this manual.

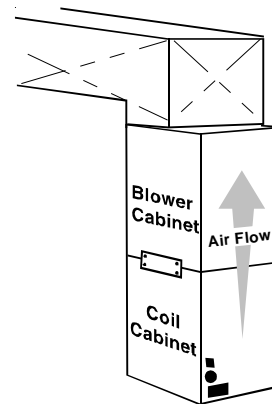

Figure 2 - Upflow Application

COUNTERFLOW INSTALLATION

For counterflow installations, the evaporator coil cabinet must sit on top of the blower cabinet (Figure 3). **NOTE:** All panels should be in place when installing the unit.

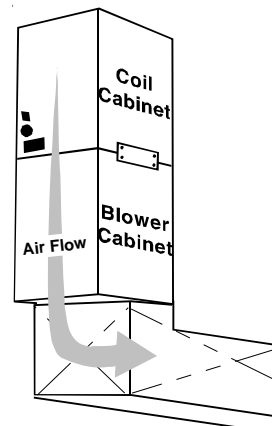

figure 3 - Counterflow Application

NOTE: Supply ductwork for counterflow applications, must be Class I. However, if combustible ductwork is used, sheet metal protection is required.

1. Place the blower and coil cabinet assembly supply outlet on the supply duct or duct opening. Ensure there is ample support for the unit and all attached ductwork.
2. Connect refrigerant and condensate drain connections per the evaporator coil installation instructions. Ensure refrigerant and drain lines do not interfere with service access to the unit.
3. Attach return ductwork. Seal connections between unit and ductwork as required to reduce/eliminate air leakage.
4. Make electrical connections as specified in “Electrical” section of this manual.

HORIZONTAL INSTALLATION

For horizontal installations, the coil cabinet must be upstream of the blower cabinet (Figures 5 and 6). **NOTE:** All panels should be in place when installing the unit.

1. Set the unit near its final installation place. The unit must be supported along the entire length of the unit. Rubber isolation pads may be used to reduce sound and vibration transmission. Ensure there is ample support for the unit and all attached ductwork.

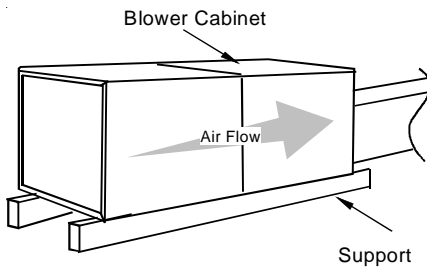

FIGURE 5 - Attic Installation

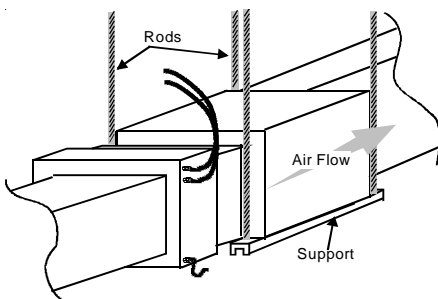

FIGURE 6 - Hanging Installation

2. If installed above a finished ceiling or living space, be sure to put a secondary drain pan under the entire unit, and pipe the drain separately from the main condensate drain.
3. Connect refrigerant and condensate drain connections per the coil section installation instructions. Ensure refrigerant and drain lines do not interfere with service access to the unit.

4. Attach return and supply ductwork. Seal connections.
5. Make electrical connections as specified in “Electrical” section of this manual.

ELECTRICAL CONNECTIONS

Consult the local power company and local codes before installing this unit. All wiring must be in accordance with the National Electrical Code as well as all local codes. Knockouts have been provided on side and top of the cabinet for the installation of the electrical conduit. If the knockouts on the cabinet sides are used for electrical conduit, an adapter ring must be used in order to meet UL1995 safety requirements. Use Minimum Circuit Ampacity and type of wire to determine proper wire size. The unit **MUST** be properly grounded. A ground lug is provided in the unit.

Check all factory connections before connecting electrical power to unit to ensure none were loosened or disconnected during shipping and handling.

⚠ WARNING
TO PREVENT PERSONAL INJURY OR DEATH DUE TO ELECTRICAL SHOCK, DISCONNECT THE ELECTRICAL POWER BEFORE ELECTRICALLY CONNECTING THE UNIT.

⚠ CAUTION
TO AVOID THE RISK OF PROPERTY DAMAGE, PERSONAL INJURY OR FIRE USE ONLY COPPER CONDUCTORS.

⚠ CAUTION
TO AVOID THE RISK OF PERSONAL INJURY, WIRING TO THE UNIT MUST BE PROPERLY POLARIZED AND GROUNDED.

⚠ WARNING
ALL WIRING MUST COMPLY WITH APPLICABLE LOCAL AND NATIONAL CODES. TYPE AND LOCATION OF FUSED DISCONNECT SWITCH(ES) MUST COMPLY WITH ALL APPLICABLE CODES AND PROVIDE OVERCURRENT PROTECTION AS SHOWN ON THE NAMEPLATE.

HIGH VOLTAGE WIRING

If heater kits will not be installed, remove the proper size knockout for the electrical conduit connection. Connect electrical conduit to the unit using two washers to make an approved connection.

The power supply wires must be connected to the red and black power wiring. Two wire nuts are provided in the bag assembly for this connection. Wrap the wire nuts with electrical tape. (Insulated crimp type connectors, field supplied, may be substituted for the wire nuts and electrical tape provided proper size connectors are used.) A ground wire **MUST** be connected to the ground lug inside the unit.

LOW VOLTAGE WIRING

Low voltage wiring connections are made at the top of the cabinet. See the "Thermostat Wiring" section of this manual for typical low voltage wiring connections. A minimum 18 AWG wire must be used for installations up to 50 feet and 16 AWG wire for installations over 50 feet.

MISCELLANEOUS ELECTRICAL

The unit transformer is factory connected for 240 V operation. If unit is to operate on 208 V, disconnect the red wires from terminal 3 of the unit transformer and connect them to terminal 2 of the unit transformer.

INSTALLER: It is important to follow these instructions when installing the MB series of air handlers.

THERMOSTAT CONNECTIONS

The following composite wiring diagrams detail various configurations in which your MB air handler can be used. Examples include single stage cooling, two stage cooling and heat pump with single or two stage electric heating. All these configurations can be applied with convenient connections to outdoor thermostat applications.

The following sections will be detailed:

- Single Stage Cooling (GMC Thermostat part # CHT18-60 or equivalent)
- Heat Pump (GMC Thermostat part #HPT18-60 or equivalent)

Each diagram details the connections between room thermostat and MB air handlers, and the connections between the MB air handlers and the Condensing Unit (or Heat Pump) with optional connections to Outdoor Thermostats.

WARNING HIGH VOLTAGE! DISCONNECT ALL POWER BEFORE SERVICING. MULTIPLE POWER SOURCES MAY BE PRESENT. FAILURE TO DO SO MAY CAUSE PROPERTY DAMAGE, PERSONAL INJURY OR DEATH.

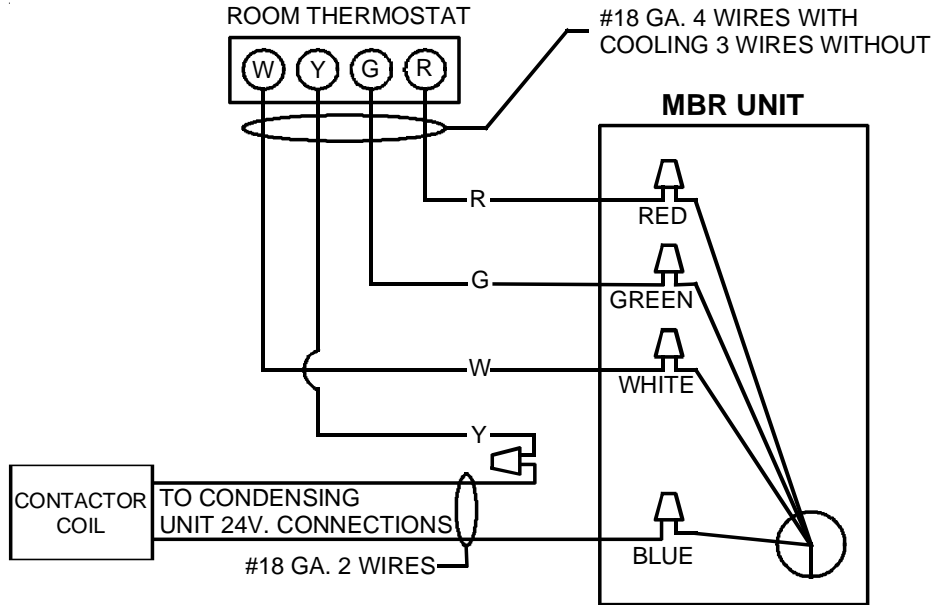

Figure 7- Low Voltage Wiring Diagram for Cooling Unit with optional heat kit 10KW and below

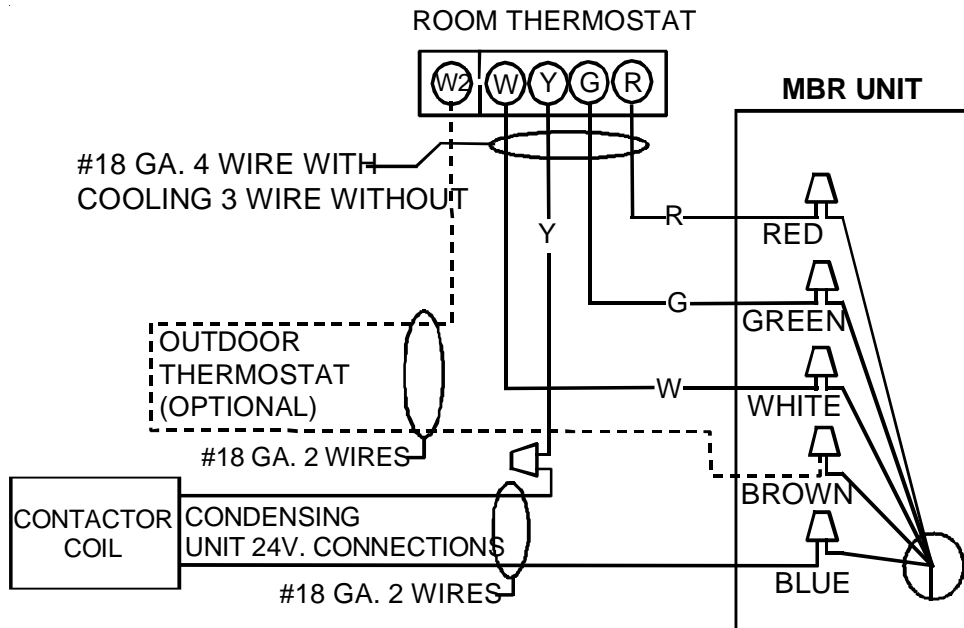

Figure 8 - Low Voltage Wiring Diagram for Cooling Unit with optional heat kit 15KW and above

Wiring is subject to change, always refer to the wiring diagram on the unit for the most up-to-date wiring.

WARNING HIGH VOLTAGE! DISCONNECT ALL POWER BEFORE SERVICING. MULTIPLE POWER SOURCES MAY BE PRESENT. FAILURE TO DO SO MAY CAUSE PROPERTY DAMAGE, PERSONAL INJURY OR DEATH.

**MBR
SYSTEM COMPOSITE DIAGRAM
800-2000
10 KW & BELOW**

FIGURE 9

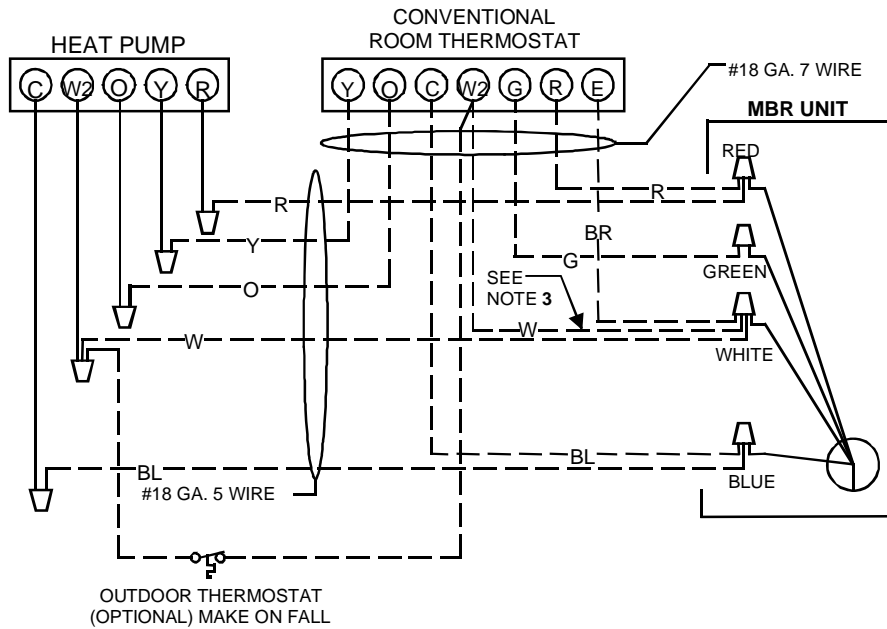

#18 GA. 6 WIRE NEEDED WHEN OT IS USED

**MBR
SYSTEM COMPOSITE DIAGRAM
1200-2000
ABOVE 10 KW**

FIGURE 10

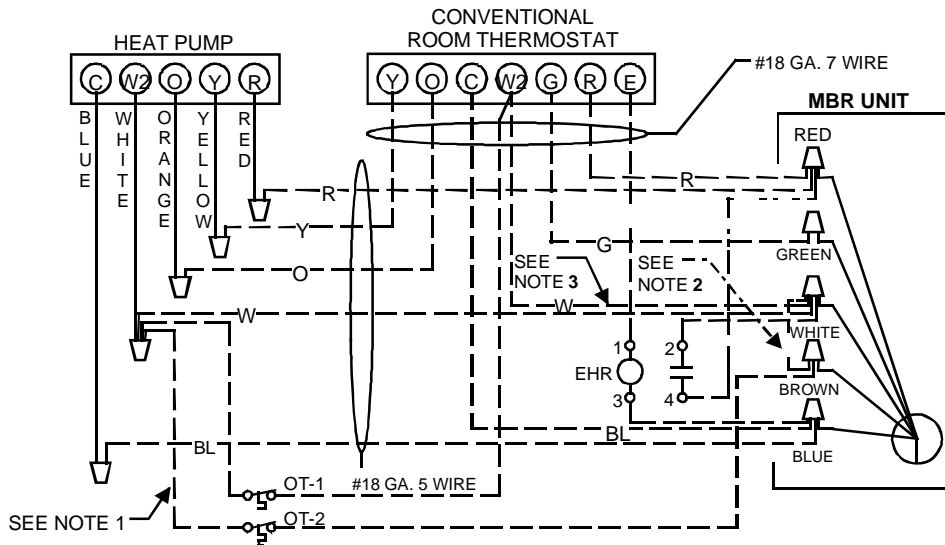

#18 GA. 7 WIRE NEEDED WHEN (2) OTs ARE USED

NOTES

- 1) OUTDOOR THERMOSTAT (OT-1) SHOULD BE THE FIRST TO CLOSE AND THE FIRST TO OPEN.
 - 2) IF OUTDOOR THERMOSTAT IS NOT USED, TIE WHITE AND BROWN WIRES FROM AIR HANDLER TOGETHER.
 - 3) REMOVE WIRE WHEN USING OUTDOOR T-STAT.
- #18 GA. 7 WIRE NEEDED WHEN (2) OTs ARE USED

NOMENCLATURE

- OT - OUTDOOR THERMOSTAT (OPTIONAL)
- MOF - MAKE ON FALL
- EHR - EMERGENCY HEAT RELAY (OPTIONAL)

COLOR CODES

- R - RED
- Y - YELLOW
- BL - BLUE
- V - VIOLET
- G - GREEN
- O - ORANGE
- W - WHITE
- PK - PINK
- G - GREEN

Wiring is subject to change, always refer to the wiring diagram on the unit for the most up-to-date wiring.

WARNING HIGH VOLTAGE! DISCONNECT ALL POWER BEFORE SERVICING. MULTIPLE POWER SOURCES MAY BE PRESENT. FAILURE TO DO SO MAY CAUSE PROPERTY DAMAGE, PERSONAL INJURY OR DEATH.

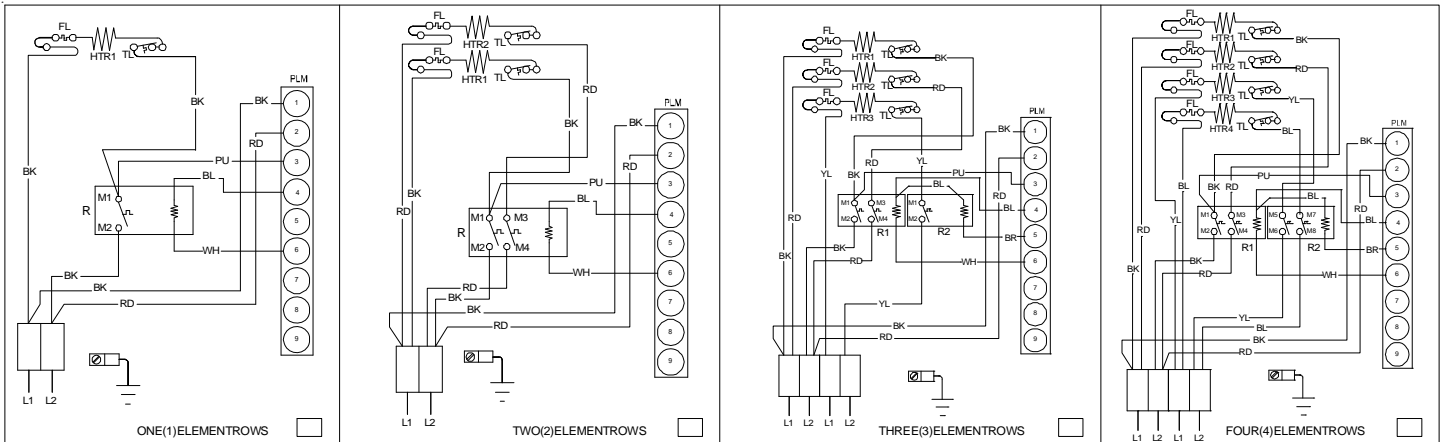

NOTE: WHEN INSTALLING HEATER KIT, ENSURE SPEED TAP DOES NOT EXCEED MINIMUM BLOWER SPEED (MBS) SPECIFIED FOR THE AIR HANDLER/HEATER KIT COMBINATION IN THIS UNIT'S SS&R PLATE. AFTER INSTALLING OPTIONAL HEAT KIT, MARK 'X' IN THE PROVIDED ABOVE. MARK ACCORDING TO NUMBER OF HEATER ELEMENT ROWS INSTALLED. NO MARK INDICATES NO HEAT KIT INSTALLED.

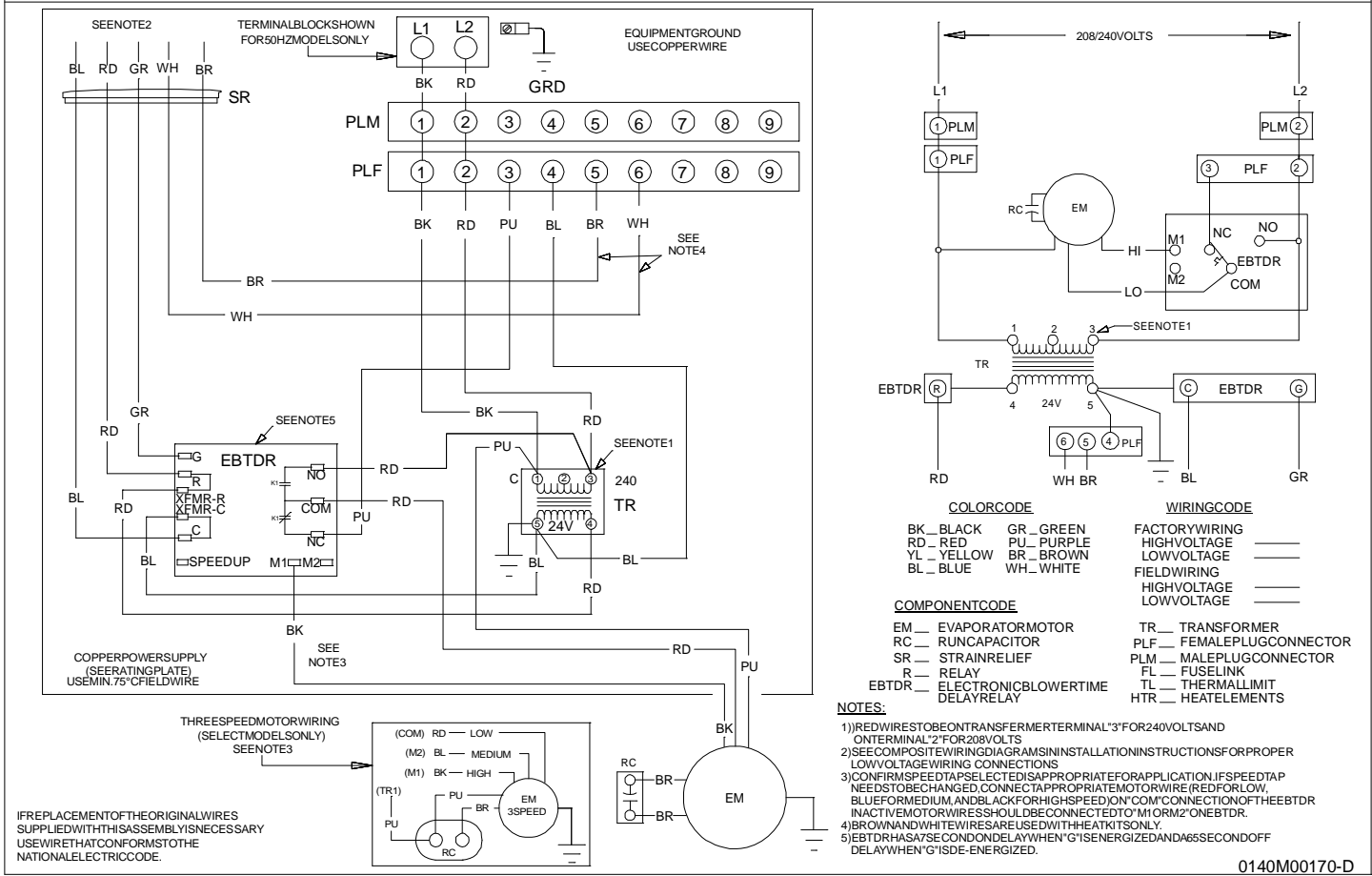

Wiring is subject to change, always refer to the wiring diagram on the unit for the most up-to-date wiring.

NOTE: SPECIFICATIONS AND PERFORMANCE DATA LISTED HEREIN ARE SUBJECT TO CHANGE WITHOUT NOTICE

Visit our website at www.daikincomfort.com, www.goodmanmfg.com or www.amana-hac.com for information on:

- Products
- Warranties
- Customer Services
- Parts
- Contractor Program and Training
- Financing Options

5151 San Felipe, Suite 500, Houston, TX 77056

© 2013 Goodman Manufacturing Company, L.P.



is a registered trademark of Maytag Corporation or its related companies and is used under license. All rights reserved.