



Air Conditioning & Heating

MBR

MULTI-POSITION MULTI-SPEED PSC MOTOR MODULAR BLOWER 1½ TO 5 TONS

Product Features

- Direct drive, multi-speed PSC blower motor
- 3 kW – 21 kW electric heat kits
- Blower section usable as electric heater
- Horizontal or vertical configuration capabilities
- 21" depth for easier attic access
- Foil-faced insulation covers the internal casing to reduce cabinet condensation
- Galvanized, leather grain-embossed finish
- AHRI certified; ETL listed

Contents

Air Handler Nomenclature	2
Heater Kit Nomenclature	2
Product Specifications	3
Dimensions	4
Airflow Data	5
Heat Kit Data.....	6
Wiring Diagram	7



* Complete warranty details available from your local dealer or at www.goodmanmfg.com. To receive the 10-Year Parts Limited Warranty, online registration must be completed within 60 days of installation. Online registration is not required in California or Quebec.

NOMENCLATURE

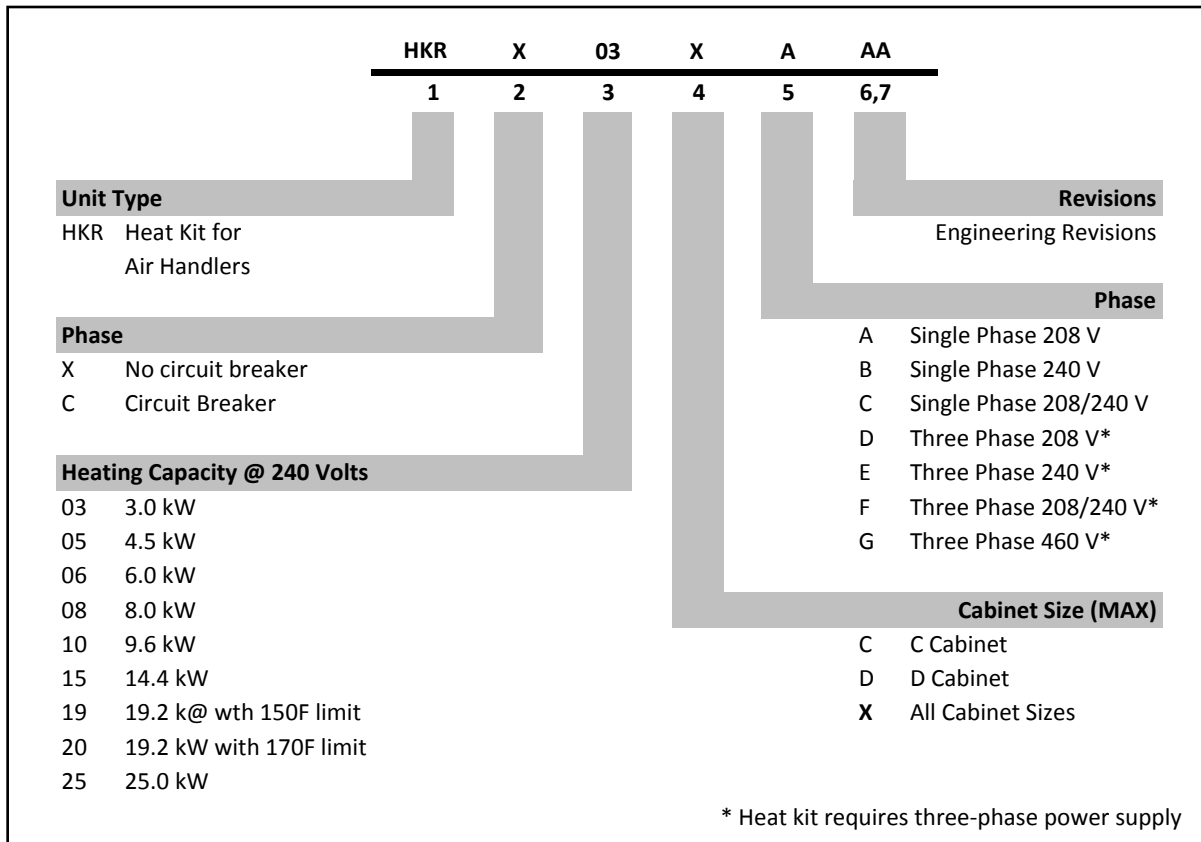
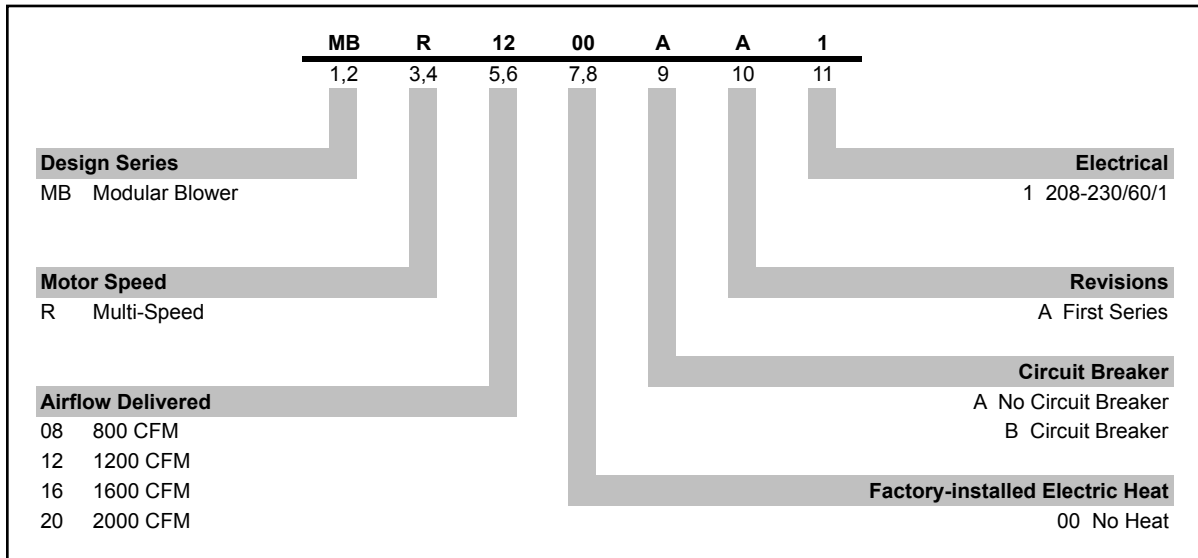

HEATING kW CORRECTION FACTOR

SUPPLY VOLTAGE	240	230	220	210	208
CORRECTION FACTOR	1.00	0.92	0.84	0.77	0.75

Multiply the 240-volt heating capacity by correction factors.

SPECIFICATIONS

MODEL	MBR0800AA-1	MBR1200AA-1	MBR1600AA-1	MBR2000AA-1
BLOWER				
Diameter	9"	9"	10"	10"
Width	6"	8"	8"	10"
ELECTRICAL DATA				
Voltage	208 / 230	208/230	208 / 230	208 / 230
Min Circuit Ampacity	1.9	3	3.8	4.9
Max. Overcurrent Device (Amps)	15	15	15	15
Blower Motor				
Horsepower (HP)	¼	⅓	⅓	½
SHIP WEIGHT (LBS.)	62	62	73	84

- Minimum Circuit Ampacity (MCA) and Maximum Overcurrent Protection (MOP) for blower without supplemental heat installed. Refer to unit nameplate for these specifications with approved accessory heaters installed.

DIMENSIONS

SIDE AND FRONT VIEWS

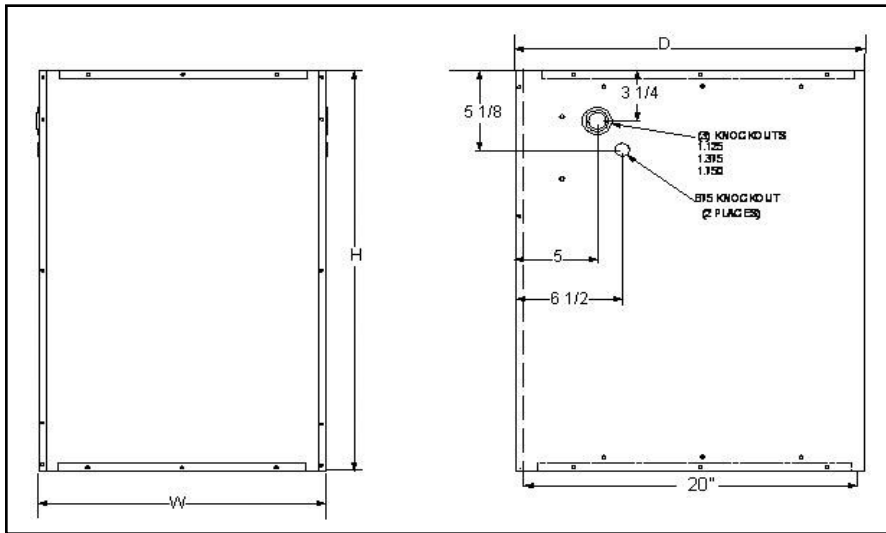

	W	H	D
MBR0800*	17½"	26"	21"
MBR1200*	17½"	26"	21"
MBR1600*	21"	30"	21"
MBR2000*	24½"	30"	21"

TOP VIEW

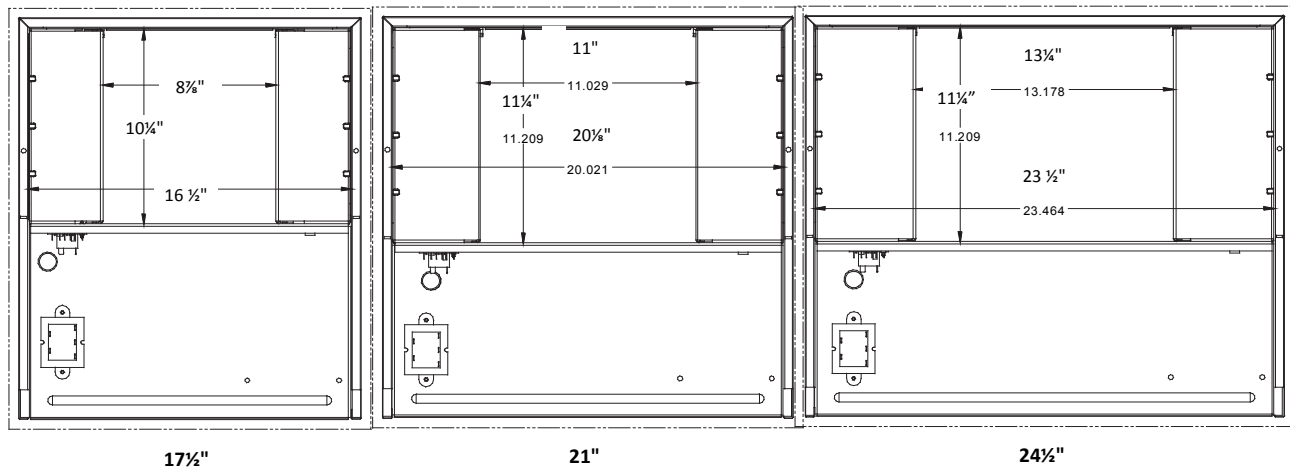

AIRFLOW DATA

SPEED	STATIC	MBR0800**_* SCFM	MBR1200**_* SCFM	MBR1600**_* SCFM	MBR2000**_* SCFM
High	0.1	1,240	1,500	1,800	2,160
	0.2	1,170	1,460	1,740	2,080
	0.3	1,120	1,360	1,680	1,990
	0.4	1,060	1,280	1,610	1,890
	0.5	980	1,200	1,520	1,790
	0.6	900	1,110	1,430	1,690
Medium	0.1	900	1,380	1,540	1,730
	0.2	850	1,320	1,490	1,670
	0.3	790	1,270	1,450	1,590
	0.4	740	1,200	1,400	1,520
	0.5	680	1,140	1,350	1,420
	0.6	605	1,040	1,280	1,320
Low	0.1	650	1,170	1,130	1,520
	0.2	590	1,130	1,100	1,450
	0.3	540	1,080	1,070	1,360
	0.4	500	1,020	1,030	1,290
	0.5	430	950	990	1,200
	0.6	330	830	930	1,090

NOTES

- The chart is for information only. For satisfactory operation, external static pressure must not exceed value shown on rating plate.
- Use the CFM adjustment factors of .98 for horizontal left, .95 for horizontal right & .96 for downflow orientations.

HEAT KIT DATA

Models	Circuit 1			Circuit 2			Single-Point Kit	
	Heater Amps	MCA ¹	MOP ²	Heater Amps	MCA ¹	MOP ²	MCA ¹	MOP ²
MBR0800AA-1 **	0 / 0	1.9 / 1.9	15 / 15	---	---	---	---	---
HKR-03*	10.8 / 12.5	15.4 / 18	20 / 20	---	---	---	---	---
HKR-05* / 05C*	17.2 / 19.8	23 / 27	25 / 30	---	---	---	---	---
HKR-06*	21.7 / 25.0	29 / 33	30 / 35	---	---	---	---	---
HKR-08* / -08C*	25.3 / 29.2	33 / 38	35 / 40	---	---	---	---	---
HKR-10* / -10C*	34.3 / 39.6	45 / 51	45 / 60	---	---	---	---	---
MBR1200AA-1 **	0 / 0	3.0 / 3.0	15 / 15	---	---	---	---	---
HKR-03*	10.8 / 12.5	17 / 19	20 / 20	---	---	---	---	---
HKR-05* / 05C*	17.2 / 19.8	24 / 28	25 / 30	---	---	---	---	---
HKR-06*	21.7 / 25.0	30.1 / 34	35 / 40	---	---	---	---	---
HKR-08* / -08C*	25.3 / 29.2	35 / 39	35 / 40	---	---	---	---	---
HKR-10* / -10C*	34.3 / 39.6	46 / 52	50 / 60	---	---	---	---	---
HKA-15C*	34.3 / 39.6	46 / 52	50 / 60	17.2 / 19.8	21 / 25	25 / 25	67/77	70 / 80
HKA-20C*	34.3 / 39.6	46 / 52	50 / 60	34.3 / 39.6	43 / 49	45 / 50	89/102	90 / 110
^HKR3-15*	0 / 0	3.0 / 3.0	15 / 15	31.3 / 36.1	39 / 45.1	40 / 50	---	---
^HKR3-20*	0 / 0	3.0 / 3.0	15 / 15	40.7 / 46.9	51 / 59	60 / 60	---	---
MBR1600AA-1 **	0 / 0	3.8 / 3.8	15 / 15	---	---	---	---	---
HKR-03*	10.8 / 12.5	17 / 19	20 / 20	---	---	---	---	---
HKR-05* / 05C*	17.2 / 19.8	25.2 / 28	30 / 30	---	---	---	---	---
HKR-06*	21.7 / 25.0	31 / 35	35 / 35	---	---	---	---	---
HKR-08* / -08C*	25.3 / 29.2	35.3 / 40.2	40 / 45	---	---	---	---	---
HKR-10* / -10C*	34.3 / 39.6	47 / 53	50 / 60	---	---	---	---	---
HKA-15C*	34.3 / 39.6	47 / 53	50 / 60	17.2 / 19.8	21 / 25	25 / 25	68/78	70 / 80
HKA-20C*	34.3 / 39.6	47 / 53	50 / 60	34.3 / 39.6	43 / 49	45 / 50	90/103	90 / 110
^HKR3-15*	0 / 0	3.8 / 3.8	15 / 15	31.3 / 36.1	39 / 45.1	60 / 60	---	---
^HKR3-20*	0 / 0	3.8 / 3.8	15 / 15	40.7 / 46.9	51 / 59	60 / 60	---	---
MBR2000AA-1 **	0 / 0	4.9 / 4.9	15 / 15	---	---	---	---	---
HKR-03*	10.8 / 12.5	18 / 21	20 / 25	---	---	---	---	---
HKR-05* / 05C*	17.2 / 19.8	26 / 30	30 / 35	---	---	---	---	---
HKR-06*	21.7 / 25.0	32 / 36	35 / 40	---	---	---	---	---
HKR-08* / -08C*	25.3 / 29.2	36 / 41	40 / 45	---	---	---	---	---
HKR-10* / -10C*	34.3 / 39.6	48 / 54	50 / 60	---	---	---	---	---
HKA-15C*	34.3 / 39.6	48 / 54	50 / 60	17.2 / 19.8	21 / 25	25 / 25	69/79	70 / 80
HKA-20C*	34.3 / 39.6	48 / 54	50 / 60	34.3 / 39.6	43 / 49	45 / 50	91/104	100 / 110
^HKR3-15*	0 / 0	4.9 / 4.9	15 / 15	31.3 / 36.1	39 / 45.1	40 / 50	---	---
^HKR3-20*	0 / 0	4.9 / 4.9	15 / 15	40.7 / 46.9	51 / 59	60 / 60	---	---

All ampacities noted above include air handler motor amps
 Circuit 1: Single-phase for Air Handlers / Circuit 2: Three-phase
 for HKR3 Heater Kits

¹ Minimum Circuit Ampacity (Heater Amps + Motor Amps) X 1.25

² Maximum Overcurrent Protection = 2.25 X Motor Amps +
 Heater Amps

* Revision level that may or may not be designated

C = Circuit Breaker Option

--- indicates Not Required

HKA meets the new UL1995 requirements for 15 and 20KW heaters

- Only applicable when HKA kits are included in table
- MBVC and MBR models

WIRING DIAGRAM – AIR HANDLER

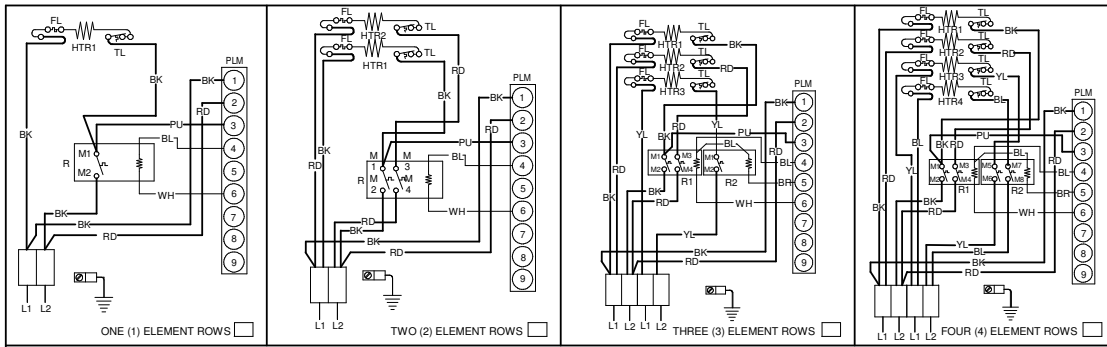

NOTE: WHEN INSTALLING HEATER KIT, ENSURE SPEED TAP DOES NOT EXCEED MINIMUM BLOWER SPEED (MBS) SPECIFIED FOR THE AIRHANDLER/HEATER KIT COMBINATION ON THIS UNIT'S INSTALLATION INSTRUCTIONS. AFTER INSTALLING OPTIONAL HEAT KIT, MARK AN "X" IN THE PROVIDED ABOVE. MARK ACCORDING TO NUMBER OF HEATER ELEMENT ROWS INSTALLED. NO MARK INDICATES NO HEAT KIT INSTALLED. 0140M0011

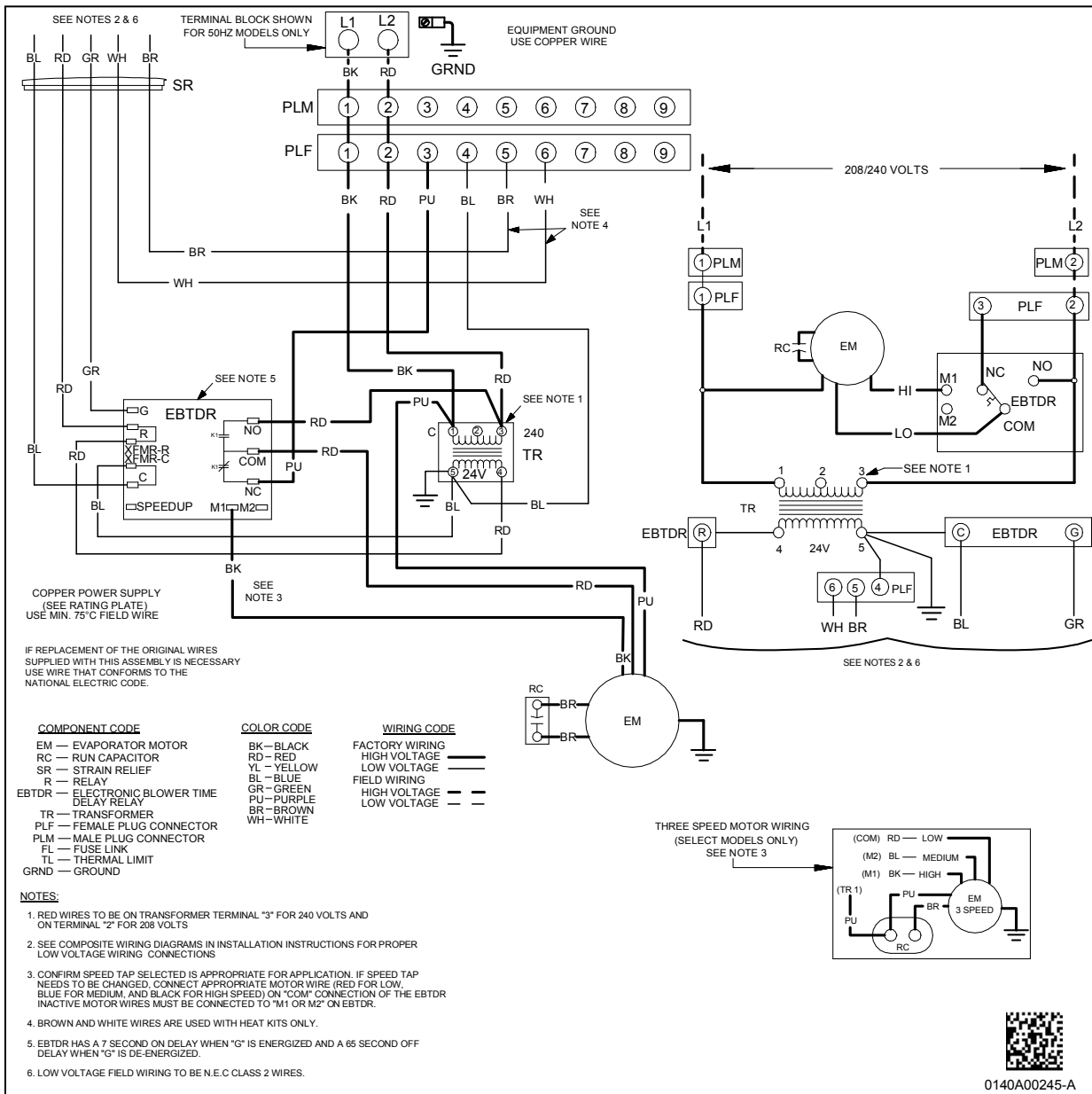

Wiring is subject to change. Always refer to the wiring diagram on the unit for the most up-to-date wiring.

WARNING

High Voltage: Disconnect all power before servicing or installing this unit. Multiple power sources may be present. Failure to do so may cause property damage, personal injury, or death.

WIRING DIAGRAM – 5 ELEMENT HEATER KIT

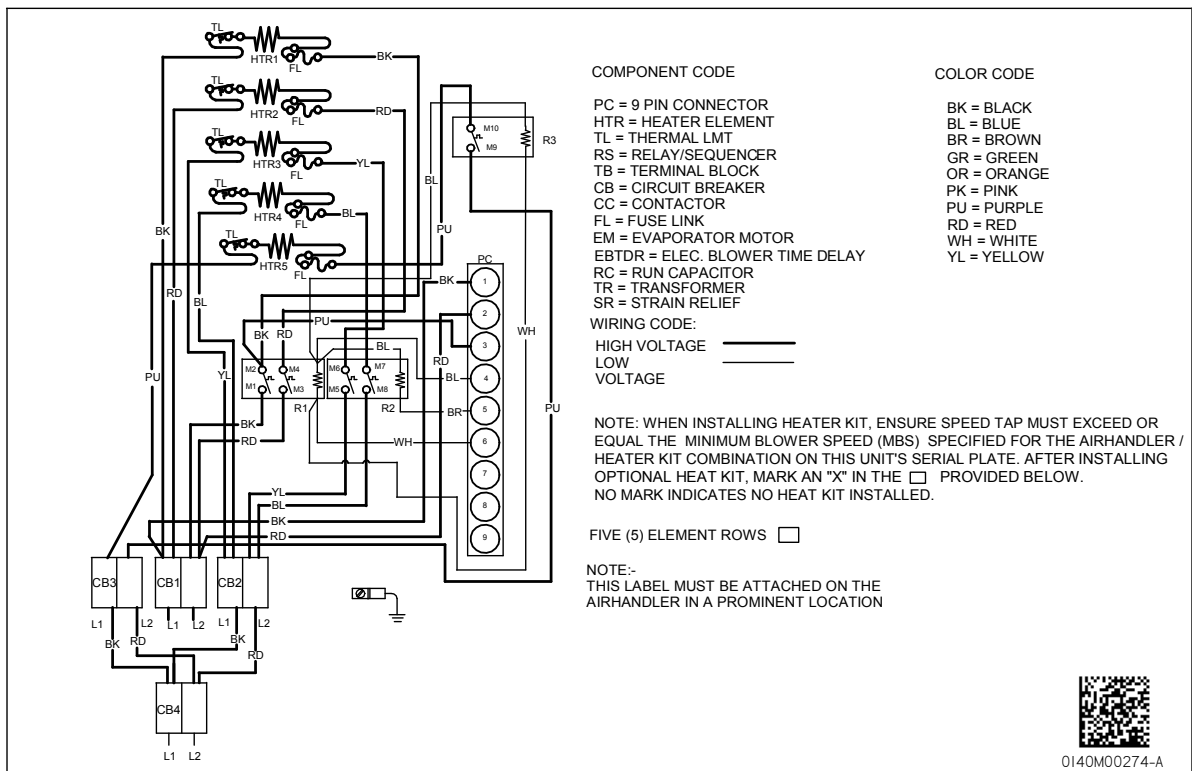

Wiring is subject to change. Always refer to the wiring diagram on the unit for the most up-to-date wiring.

	WARNING	<p>High Voltage: Disconnect all power before servicing or installing this unit. Multiple power sources may be present. Failure to do so may cause property damage, personal injury, or death. </p>
--	----------------	---