



www.swisherinc.com

OWNER'S MANUAL

STARTING SERIAL #
L101-344001

MODEL NO.

T1360B1

T1360T

T1360H

T1360K

T13560

RK1360

T14560

T17560



IMPORTANT

Read and follow all
Safety Precautions
and Instructions
before operating this
equipment.

Rev: 05-007

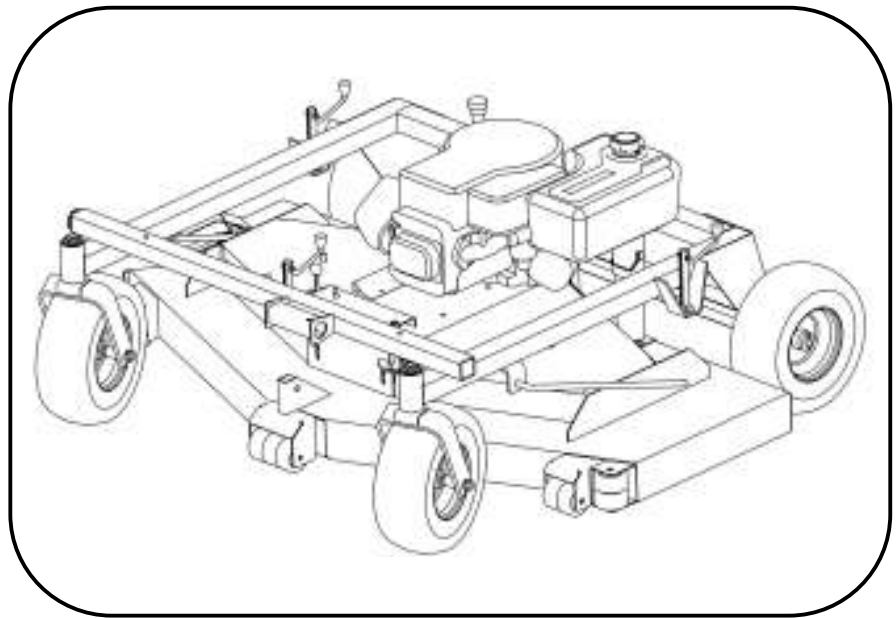

60" FINISH CUT TRAILMOWER



**Assembly
Operation
Service and Adjustment
Repair Parts**

P.O. BOX 67, WARRENSBURG, MISSOURI 64093 PHONE 660-747-8183 FAX 660-747-8650

Manufacturing quality lawn care equipment since 1945

Made In The

USA

LIMITED WARRANTY

The manufacturer's warranty to the original consumer purchaser is: This product is free from defects in materials and workmanship for a period of one (1) year from the date of purchase by the original consumer purchaser. We will repair or replace, at our discretion, parts found to be defective due to materials or workmanship. This warranty is subject to the following limitations and exclusions:

- 1) Engine Warranty All engines utilized on our products have a separate warranty extended to them by the individual engine manufacturer. Any engine service difficulty is the responsibility of the engine manufacturer and in no way is Swisher Mower Co., Inc. or its agents responsible for the engine warranty. The Briggs & Stratton Engine Service Hot-Line is 1-800-233-3723. The Tecumseh Engine Service Hot-Line is 1-800-558-5402.

- 2) Commercial Use The warranty period for this product used for commercial or rental is limited to ninety (90) days from the date of original purchase.

- 3) Limitations This warranty applies only to products which have been properly assembled, adjusted, and operated in accordance with the instructions contained within this manual. This warranty does not apply to any product of Swisher Mower Co., Inc., that has been subject to alteration, misuse, abuse, improper assembly or installation, shipping damage, or to normal wear of the product.

- 4) Exclusions Excluded from this warranty are normal wear, normal adjustments, and normal maintenance.

In the event you have a claim under this warranty, you must return the product to an authorized service dealer. All transportation charges, damage, or loss incurred during transportation of parts submitted for replacement or repair under this warranty shall be borne by the purchaser. Should you have any questions concerning this warranty, please contact us toll-free at 1-800-222-8183. The model number, serial number, date of purchase, and the name of the authorized Swisher dealer from whom you purchased the mower will be needed before any warranty claim can be processed.

SAFETY PRECAUTIONS



This Safety Alert Symbol indicates important messages in this manual. When you see this symbol, carefully read the message that follows and be alert to the possibility of personal injury.

Read this manual completely. This machine can amputate hands, feet, and throw objects. Failure to observe the following safety instructions could result in serious injury or death.

- Read the manual. Learn to operate this machine safely.
- Always disconnect the spark plug wire and place the wire where it cannot contact the spark plug, to prevent accidental starting the engine when setting up, transporting, adjusting or making repairs.
- Keep all shields and guards in place.
- Understand the speed, steering and stability of this machine. Know the positions and operations of all controls before you operate this machine. Check all of the controls in a safe area before starting to work with this machine.
- Allow only responsible adults who are familiar with these instructions to operate this machine. Never allow children to operate this machine.
- Clear the area of objects such as rocks, toys, wire, etc. that can be picked up and thrown by the blade.
- Be sure the area is clear of other people before mowing. Be aware of the mower discharge direction and do not point at anyone. Stop the machine if anyone enters the mowing area. Children are often attracted to the machine and the mowing activity. ***Never assume that children will remain where you last saw them.*** Keep children under the watchful care of another responsible adult.
- **No riders!**
- Do not put hands or feet near or under rotating parts. Keep clear of the discharge opening at all times.
- Do not mow in reverse. Always look down and behind before and while backing.

- Turn off the blades when not mowing. Before leaving the machine, turn off the blades and stop the engine.
- Watch for traffic when operating near or crossing roadways.
- Do not operate the mower if it has been dropped or damaged in any manner or if the mower vibrates excessively. Excessive vibration is an indication of damage. Repair mower as necessary.
- Dress properly. Do not operate the mower when barefoot or wearing open sandals. Wear only solid shoes with good traction when mowing.
- Do not operate the machine while under the influence of alcohol or drugs.
- Do not operate on slopes greater than 15 degrees.
- Never tamper with safety devices. Check their proper operation regularly.
- Stop and inspect the equipment if you strike an object. Repair, if necessary, before restarting.
- Never make adjustments or repairs with the engine running.
- Mower blades are sharp and can cut. Wrap the blades or wear gloves, and use extra caution when servicing them.

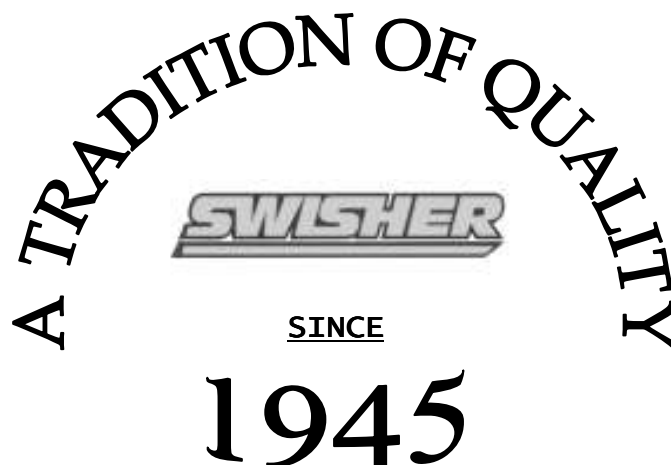



SAFETY DECALS

Replace decals immediately if damaged. Order by part number from Swisher Mowers



OD45- Warning Decal



OD11- No step Decal



OD55- Triangle Danger Decal



OD43- Flying Debris Decal



OD33- Speed Decal



OD29- Danger Decal

REQUIRED ASSEMBLY

FRONT WHEEL CASTER ASSEMBLY

1. Remove single nut and washers from caster shaft.
2. Place one washer on the shaft of the caster/wheel sub-assembly.
3. Slide same shaft through the bearing/frame with wheel towards the ground.
4. Place the other washer on the shaft; it should be resting on the top bearing.
5. Thread nyloc jam nut onto shaft.
6. Tighten nut snugly, making sure shaft threads enter the nyloc of the nut. **Over-tightening of this nut will bind caster.**
7. Repeat process for other front side.

REAR WHEEL ASSEMBLY

1. Remove cotter pin from axle.
2. Slide washer [NB149] if necessary and wheel [valve stem out] onto axle and replace cotter pin.
3. Bend cotter pin so it will not fall out.
4. Repeat process for other wheel.

OFFSET & CENTER TOW HITCH BAR ASSEMBLY

1. Lay out parts according to the diagram.
2. Insert part 661A into part 662 and pin with the hitch pin (H11).
3. Insert part 661 into part 661A. Choose from the 3 holes to set the desired hitch length. Pin with a hitch pin.
4. Part 662 slides into the front tube of the frame. Again, choose from the 3 holes to arrange desired offset. Pin with a hitch pin (H11).
5. Eliminate step 3 for hitching from the center bracket. Only one method can be used at a time.

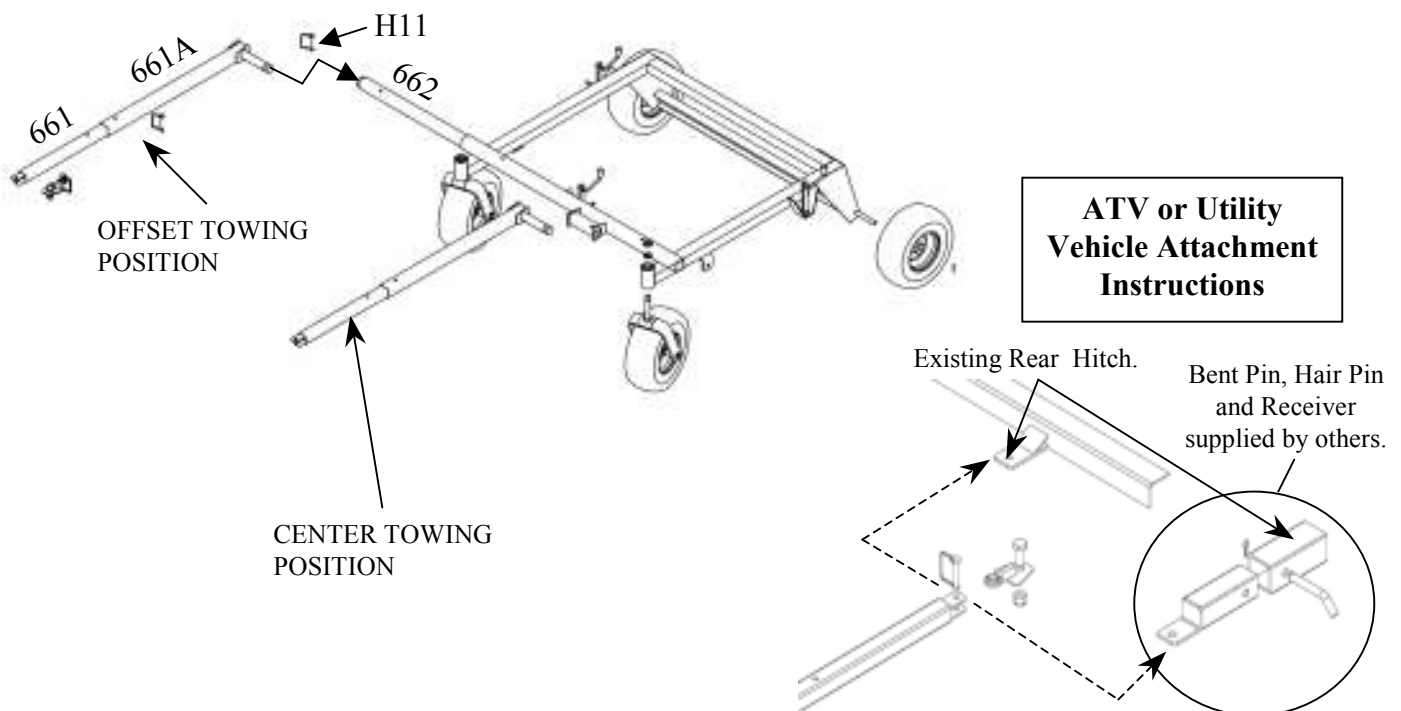

OPERATING YOUR TRAILMOWER



The operation of any mower can produce foreign objects to be thrown into the eyes, resulting in severe eye damage. Always wear certified safety glasses or wide-vision safety goggles over spectacles before starting any cutting machine and while operating such a machine.



The operation of any cutter produces sound waves that are damaging to the human ear. Ear protection is recommended.



CAUTION!

Tragic accidents can occur if the operator is not alert to the presence of children. Children are often attracted to the machine and the mowing activity. ***Never assume that children will remain where you last saw them.***

INTENDED USE

This TrailMower is designed to produce a quality finish cut on lawns, golf courses, etc. It is **not** designed to clear brush or cut saplings. Your TrailMower should be towed behind an ATV, a golf cart, lawn tractor, or similar approved vehicle. It is not meant for speeds exceeding 5 MPH.

ATTACHING TRAILMOWER TO TOW VEHICLE

- Place mower behind vehicle and back vehicle up to desired attaching position.
- When offsetting TrailMower do so to side opposite the discharge of the tow vehicle.
- Bolt swivel hitch (H10) to vehicle tow receiver.
- Attach tow hitch (661) to the swivel hitch with hitch pin (H11). Make certain hitch pin goes completely through each piece and is clipped to prevent accidental separation.
- Attach red safety tether (H9C) to both the towing vehicle and to the TrailMower toggle switch (685SP), located on the throttle housing (6013). Its purpose is to manually stop mower engine or to stop mower engine in case the two machines become separated. (See Motor Base Detail #22).
- **It is extremely important the safety tether is secured properly to both the toggle switch and the towing vehicle.**

STARTING THE ENGINE

See engine manufacturer's instructions for the type and amount of oil and fuel used. TrailMowers with electric start engines will need a battery (sold separately). Swisher recommends using a standard "U 1 R" lawn & garden battery.

- Engine must be level to accurately check and fill oil. Do not overfill.

- Make sure the tow vehicle parking brake is set, mower is level, and blades are disengaged.
- Check spark plug wire, oil, and fuel.
- Check all electrical connections (See Schematics).
- Make sure toggle switch is turned “ON” and the red tether is properly attached.
- Set engine idle to “CHOKE” position.
- With feet clear of mower deck, turn key switch to the “START” position; [if unit is equipped with 12 volt system] release when engine begins to run.
- For units NOT equipped with electric start turn key to “ON” position and pull starter Rope until engine starts.
- Set engine idle at desired RPM.

BREAKING IN YOUR MOWER

- Set vehicle parking brake or chock wheels to prevent accidental rolling.
- Start engine properly.
- Slowly, engage blade control.
- In a safe environment, i.e. no children, allow blades to rotate and engine to idle for 5 minutes. This breaks in the belts and the engine.
- Stop mower properly.



CAUTION!

SHUT OFF MOWER ENGINE AND REMOVE SPARK PLUG WIRE FROM SPARK PLUG BEFORE MAKING ANY ADJUSTMENTS TO THE MOWER.

MOWER HEIGHT ADJUSTMENT

- Adjust while mower is **not** running.
- The cutting range is approximately 1.5” to 4.5”. The height has been measured from the ground to the blade tip without the engine running.
- Rotate height adjust crank handles (H7N) in a clockwise direction to lift the mower deck. A counter-clockwise direction is used to lower the mower deck.
- Make sure the height adjustment is the same at side crank handles. For best results, see “SUGGESTED PRACTICE” section. Graduated scales are for reference only, not the actual cutter height.
- Place crank handle in a retracted position to maintain height adjustment.

STARTING TO MOW

- Adjust the cutting height.
- Double check vehicle to mower attachment.
- Start mower engine properly.
- Slowly, activate the blade engage lever (6008) by rotating it forward and left until the lever locks into place.
- Carefully mount tow vehicle and start mowing slowly.

ALTERNATIVE STOPPING METHOD

- Bring vehicle to complete stop, shut off engine, and set parking brake.
- Disengage blade engage lever (6008).
- Manually shut toggle and key switches to their “OFF” positions.
- Always remember to remove keys to avoid irresponsible usage.

TRANSPORTING MOWER

- Stop mower properly.
- Place mower deck in its highest position.
- If transporting unattached from tow vehicle, then remove spark plug wire and place where it cannot contact the spark plug.

SUGGESTED MOWING PRACTICES

- Operate mower engine at full throttle to assure the best cutting performance and maximum material discharge.
- Allow wet grass to dry. Clumps of wet grass will collect under the mowing deck.
- Mowing should be started with tow vehicle in low gear and increased only as safe mowing conditions permit. This speed should not exceed 5 MPH.
- The average lawn should be cut to approximately 2.5” during the cool season and to over 3” during the hot months.
- For a healthier lawn and better aesthetics, your lawn should be mowed often and after moderate growth.
- When cutting high or dense grass areas go slowly. Some areas may need to be mowed twice. The second cut should be at 90 degrees to the first, if possible.
- **Mowing thick or high grass.** Raise rear height crank handles to .5”-.75” above the other two handles.
- **Creating a manicured lawn.** Lower rear height crank handle to .25”-.5” below front of deck. This allows grass blades to be cut twice. It also continually cuts clippings to produce a mulching effect.

GENERAL TROUBLE SHOOTING

- The mower is not cutting level.
 - Level deck, making sure the side crank-handles are equal.
 - Check air pressure of all tires; make sure they are equal (about 15-18 psi).
 - Examine blades for damage, while mower engine is not running.
- The engine will not start.
 - Disengage blades, turn toggle switch to “ON” position, check battery and all other electrical connections, and inspect spark plug and wire.
 - Check for fuel in the engine.
- Engine runs poorly.
 - See engine manual.
 - Check throttle adjuster.
 - Replace fuel, clean fuel filter and fuel line.



IF PROBLEMS PERSIST HAVE A QUALIFIED MECHANIC SERVICE THE MOWER. NEVER ATTEMPT TO MAKE AN ADJUSTMENT THAT YOU ARE NOT SURE IS CORRECT. DOING SO CAN CAUSE OTHER PROBLEMS.

MOWER MAINTENANCE

GENERAL RECOMMENDATIONS

The warranty on this Trailmower does not cover items that have been subjected to operator abuse or negligence. To receive full value from the warranty, operator must maintain unit as instructed in this manual. Some adjustments will need to be made periodically to maintain your unit properly. All adjustments in this manual should be checked at least once each season.

BEFORE EACH USE

- Check engine oil level on a level surface. (Check twice to insure an accurate reading.)
- Check condition of air filter; clean and replace as necessary.
- Check blade operation; keep blades in good condition.
- Check for loose fasteners and tighten them as needed.

AFTER EACH USE

- Keep blades sharp.
- Remove fresh grass clippings with garden hose.
- Grass clippings can harden to the underside should be scraped out with a putty knife.
- Keep fluids at proper levels.
- Cover unit to prevent rain or other debris build-up. Definitely cover the engine.

BEFORE AND/OR AFTER EACH SEASON

- Replace the spark plug.
- Clean or replace the air filter.
- A new spark plug and clean air filter assure proper air-fuel mixture and help your engine run better and last longer.
- Check blades and belts for wear. Replace as necessary.

STORAGE RECOMMENDATIONS

⚠ CAUTION! Do not store engine indoors or other poorly ventilated area. Keep engine away from gas appliances where fumes could contact open flame, pilot lights, or sparks.

⚠ If engine is to be stored for 30 or more days, prepare unit as follows:

- Drain fuel outside into an approved container.
- Start engine properly and run until unit is out of fuel.
- Let engine cool.
- Remove remaining gasoline from carburetor and fuel tank to prevent gum deposits from forming within the engine. Gum deposits can cause malfunction in the engine.
- Store mower with blades disengaged to prevent belts from being permanently stretched.

BLADE CARE AND SERVICE

For best results cutter blades must be kept sharp. The blades can be sharpened with a few strokes of a file or grinding wheel. Do not attempt to sharpen blades while they are on the cutter. ***Disconnect spark plug wire before servicing unit.***

Important: Replace blades that have been damaged or deeply nicked.

Important: Check blade and spindle hardware on a regular basis to make sure nuts are tight.



Only a qualified mechanic should be used for any adjustments, disassembly or other kind of repairs.

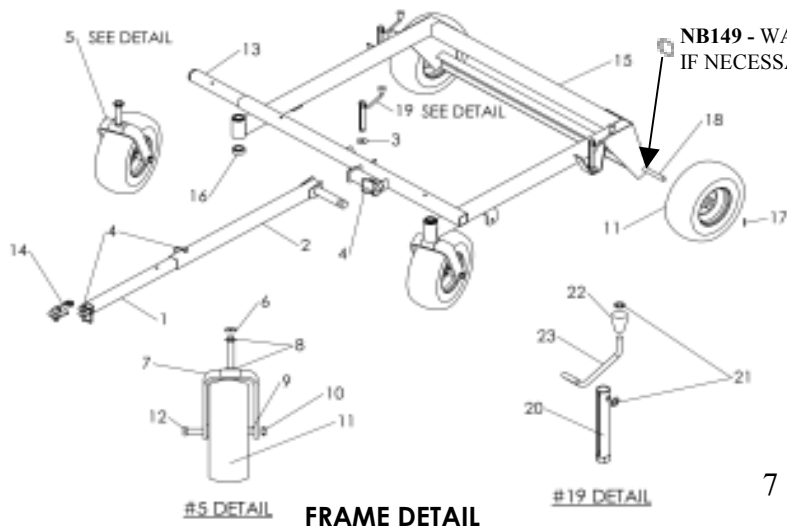

#5 DETAIL FRAME DETAIL

#19 DETAIL

ITEM #	DESCRIPTION	PART #
1	TONGUE HITCH	661 *
2	SOLID STOCK HITCH	661A *
3	WASHER	NB177
4	SAFETY HITCH PIN	H11
5	CASTERWHEEL ASSEMBLY	6774 *
6	3/8-16 JAM NUT	NB122
7	CASTER FORK	665TC
8	WASHER	NB195
9	WHEEL SPACER	663L
10	5/8-11 1/2 WAY LOCK NUT	NB595
11	WHEEL TRIGGER	F4157W
12	5/8-11 1/2 BOLT	NB624
13	EXTENSION HITCH	952 *
14	SWAYL HITCH	H10
15	FRAME	6014 *
16	BEARING	B98
17	OUTER PIN	NB126
18	REAR AXLE	6034
19	HEIGHT ADJUST HANDLE	H7N
20	HOUSING TUBE	H7N1TK
21	5/16 PIN NUT	NB276
22	PLASTIC KNOB	H7K
23	CRANK ARM	E6214
NB	HEIGHT INDICATOR	DCM1
*	USE PAINT CODE: TC=RED, TK=BLACK	EX: 6014TC,6014TK

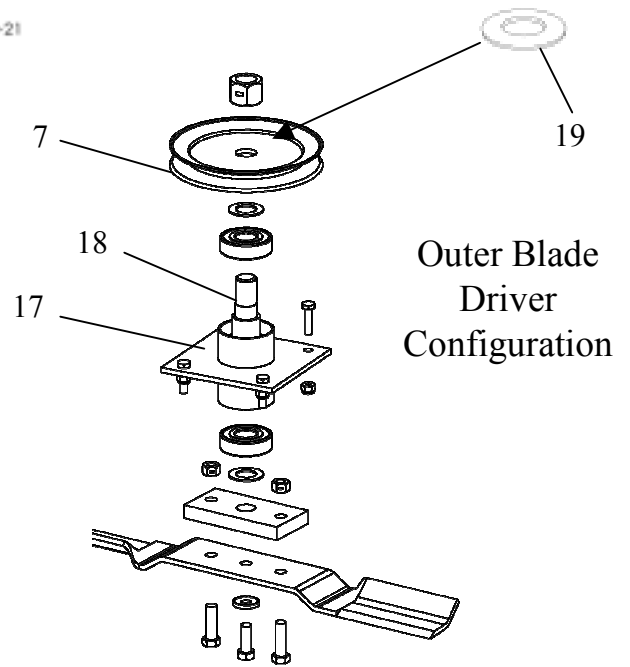

Outer Blade Driver Configuration

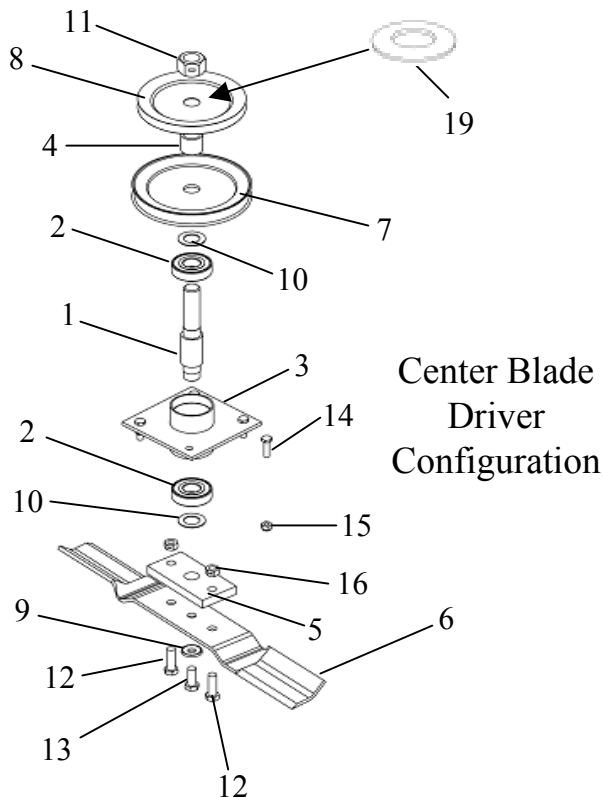

Center Blade Driver Configuration

Blade Driver Assy.
 9058- 5.75" (Center Shaft)
 9018- 4.25" (Outer Shafts)

Item No.	Description	Part #
1	Center Shaft	9054
2	Blade Bearing	B98
3	Bearing Housing	9057TK
4	Pulley Spacer	6065PM
5	Blade Mount Plate	9008
6	20 1/2 "Blade	9004
7	Blade Pulley- 5.5"	6114
8	Blade Pulley- 5.5"	6114
9	SP Washer Bellm. PLN .413 X .945 X .118	NB-607
10	3/4 ID X 1 1/4 OD 18 GA Washer	NB-179
11	3/4-16 Jam Nut	NB-175
12	3/8-24 X 1 1/4 HCC GR5 ZP	NB-238
13	3/8-24 X 1 Engine Bolt Locktite	NB-238N
14	1/4-20 X 1"- Bolt	NB-250
15	1/4-20 Serr.Flange Bolt	NB-524
16	3/8-24 2-Way Lock Nut	NB-216
17	Housing Blade Bearing Short	B99EC
18	Blade Shaft 4.25"- Short Shoulder	9076
19	Belleville Washer	AS155

GAS TANK ASSEMBLY

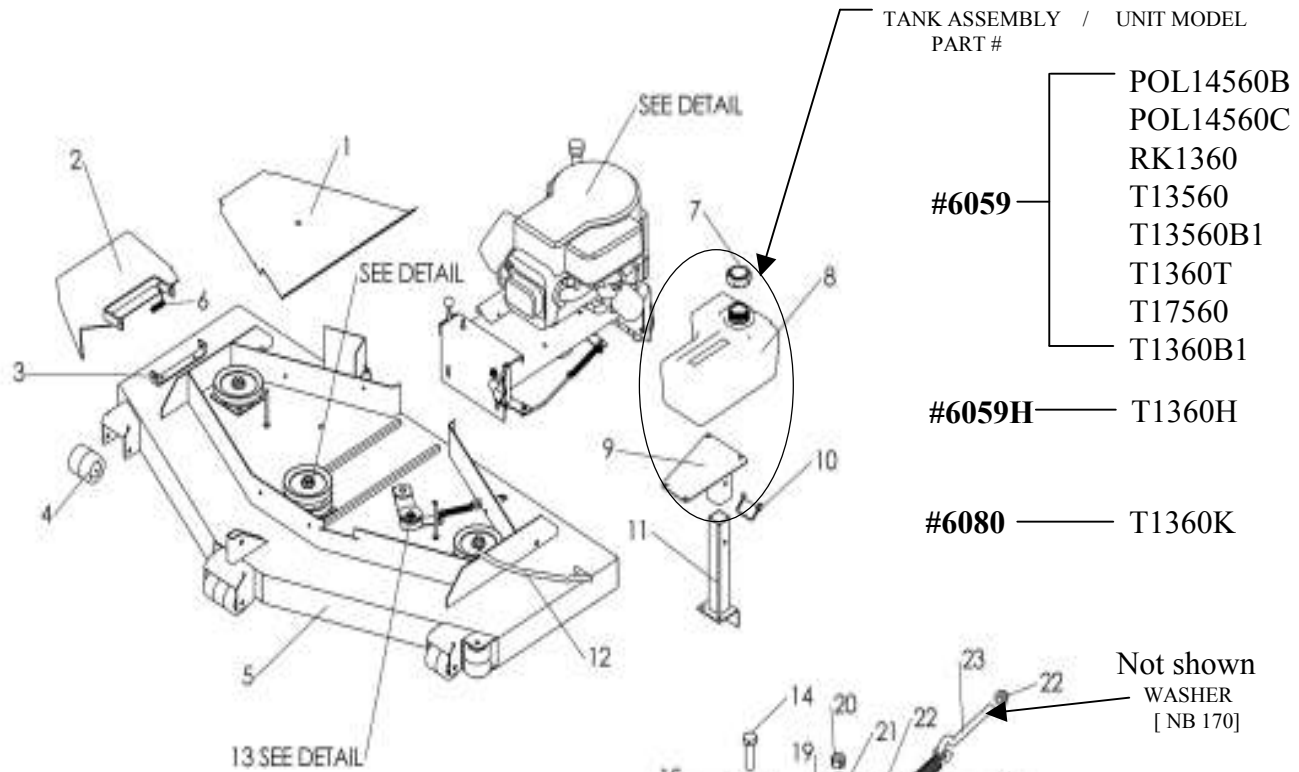

MOWER DECK DETAIL

ITEM #	DESCRIPTION	PART #
1	BELT COVER	6025TK
2	GRASS CHUTE	6039TK
3	CHUTE BRACKET	6030TK
4	ANTI SCALP ROLLER	AS001
5	DECK WELDMENT	6027*
6	CHUTE SPRING	9100
7	GAS CAP	6102NC
8	GAS TANK	6102T
9	TANK BRACKET	6049TK
10	HITCH PIN	H11
11	GAS TANK STAND	6044TK
12	SWAY BAR	3864 & 3865
13	BELT TENSION IDLER	6055
14	3/8-16 X 1 1/4 BOLT	NB618
15	SPACER	6040
16	IDLER ARM	6054TK
17	BUSHING	6037
18	3/8-16 NYLON NUT	NB182
19	IDLER PULLEY	B527
20	3/8-16 2 WAY LOCK NUT	NB280
21	3/8 WASHER	NB272
22	5/16-18 NYLON NUT	NB181
23	5/16-18 EYE BOLT	NB315
24	TENSION SPRING	TZ2S
25	5/16-18 NUT	NB173
26	5/16-18 X 1 BOLT	NB501
27	3/8-16 X 1 1/2 BOLT	NB107
*	USE PAINT CODE: TC=RED, TK = BLACK	EX: 6060TC, 6060TK

BELT CONFIGURATION

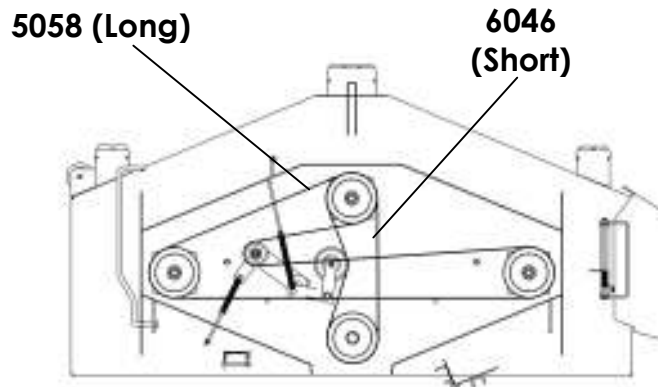

Slide plastic tube snug against toggle switch.

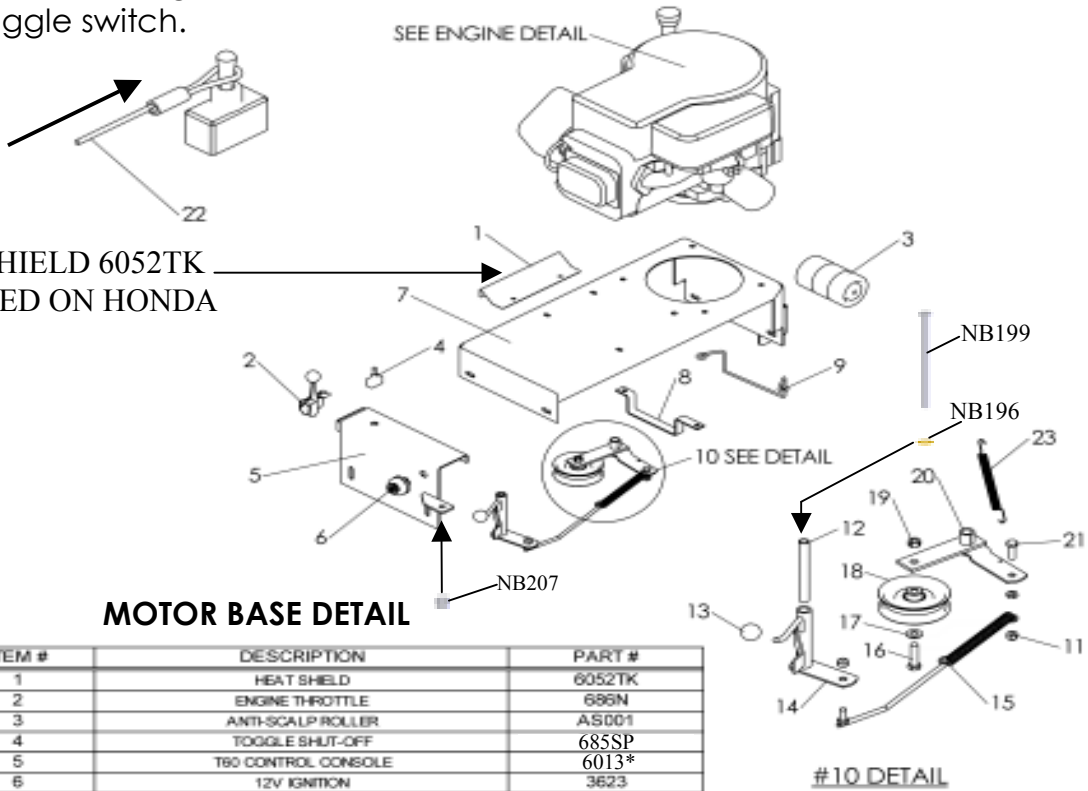

MOTOR BASE DETAIL

ITEM #	DESCRIPTION	PART #
1	HEAT SHIELD	6052TK
2	ENGINE THROTTLE	686N
3	ANTI-SCALP ROLLER	A5001
4	TOGGLE SHUT-OFF	685SP
5	T80 CONTROL CONSOLE	6013*
6	12V IGNITION	3623
7	T80 MOTOR BASE	6003 *
8	BELT GUIDE	6066
9	BELT GUIDE	6000
10	TOP IDLER ASSEMBLY	6056
11	5/16-18 NYLOK NUT	NB181
12	ENGAGE BUSHING	6713
13	PLASTIC KNOB	B19BLACK
14	ENGAGE LEVER	6008TK
15	ENGAGE ROD ASSEMBLY	6057
16	3/8-16 X 1 1/2 BOLT	NB107
17	WASHER	NB272
18	IDLER PULLEY	B527
19	3/8-16 TWO WAY LOCK NOT	NB280
20	TOP IDLER WELDMENT	6009TK
21	5/16-18 X 1 BOLT	NB501
22	SAFETY TETHER	H9C
23	RETURN SPRING	T25M
*	USE PAINT CODE: TC=RED, TK=BLACK	EX: 6003TC, 6003TK

PARTS NOT SHOWN

Description	Part #
WIRING HARNESS [BRIGGS]	WHN60B2
WIRING HARNESS [TECUMSEH]	WH60T01
BATTERY [U 1 R]	SOLD SEPARATELY
BATTERY CABLE- RED	BCSR
BATTERY CABLE- BLACK	BCLB
SOLENOID	9043
BATTERY STRAP	BHOLD
KEYS	KSK
BATTERY CABLE BOOTS	BCBT
WIRING HARNESS [HONDA]	WHN60H2
WIRING HARNESS [KOHLER]	WHN60K2

ENGINE DETAIL

BRIGGS / TECUMSEH > DETAIL - 1

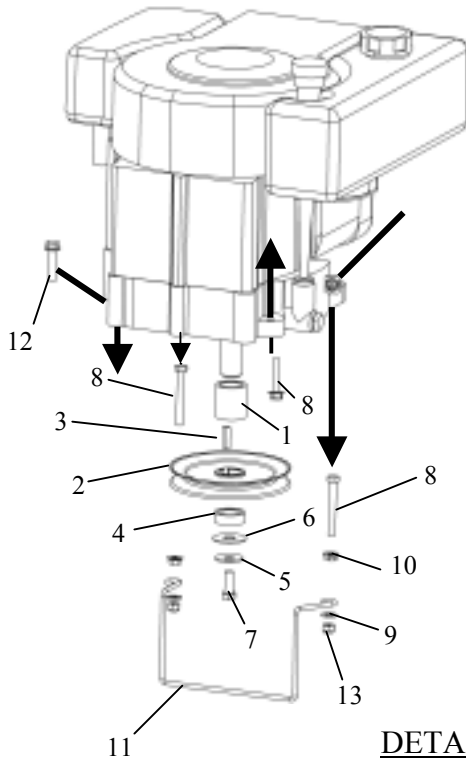

DETAIL - 2

Item No.	Description	Part #
14	SP WASHER BELLVL. PLN.	NB607
15	M8-1.25 X 25 FLG BOLT	NB728
16	M8-1.25 X 55 ZP. BOLT	NB721

DETAIL - 1

Item No.	Description	Part #
1	UPPER SPACER	689L
2	5-1/2" ENGINE PULLY	688
3	1/4" X 1" KEY STOCK	9031
4	LOWER SPACER	689S
5	3/8 BELLEVILLE WASHER	699
6	FLAT WASHER	TR150W
7	3/8-24 X 1 BOLT [BRIGGS]	NB452N
	7/16-20 X 1 BLOT [TECUMSEH]	NB238N
8	5/16-18 X 1-3/4 BOLT	NB515
9	5/16 USS WASHER	NB275
10	5/16-18 Flge NUT	NB170
11	BELT GUIDE	6000
12	5/16-18 X 1 1/4 FLG.BOLT	NB253
13	5/16-18 NYLOCK NUT	NB181

ENGINE DETAIL

KOHLER > DETAIL - 2

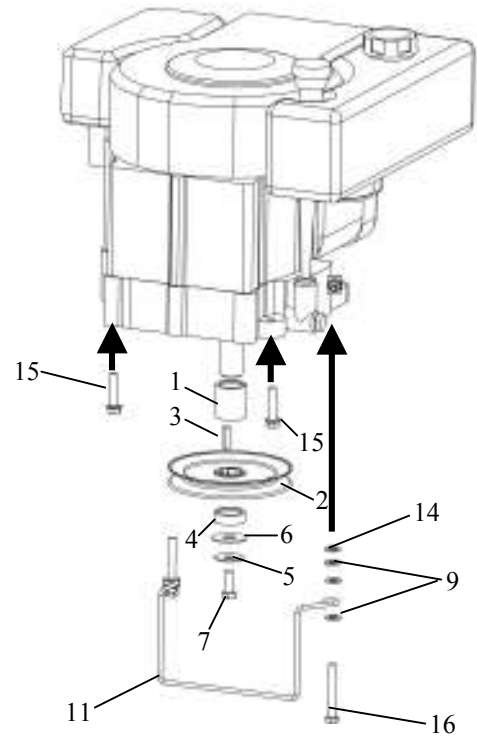

DETAIL - 3

Item No.	Description	Part #
17	5/16-24 X 1" BOLT	NB451
18	5/16-18 NYLOCK NUT	NB181
19	5/16-24 x 1-1/2" BOLT	NB233

ENGINE DETAIL HONDA > DETAIL - 3

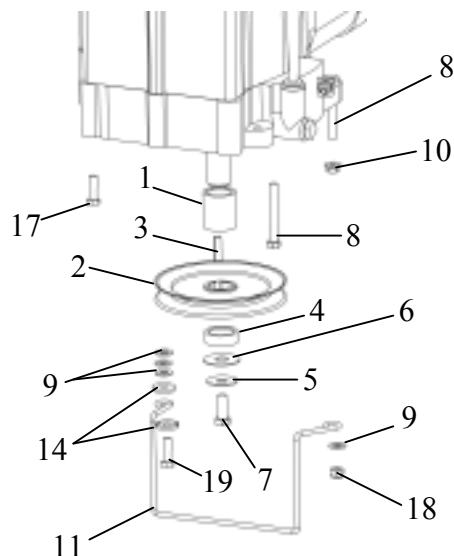

WIRING SCHEMATICS

HONDA ENGINES

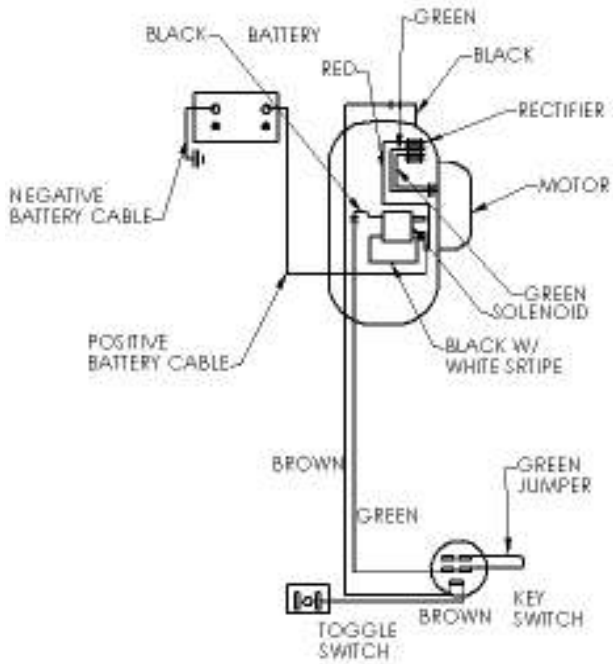

TECUMSEH ENGINES

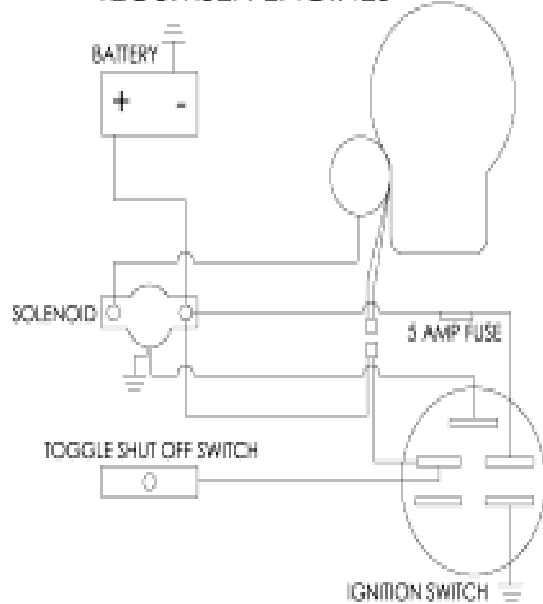

KOHLER ENGINES

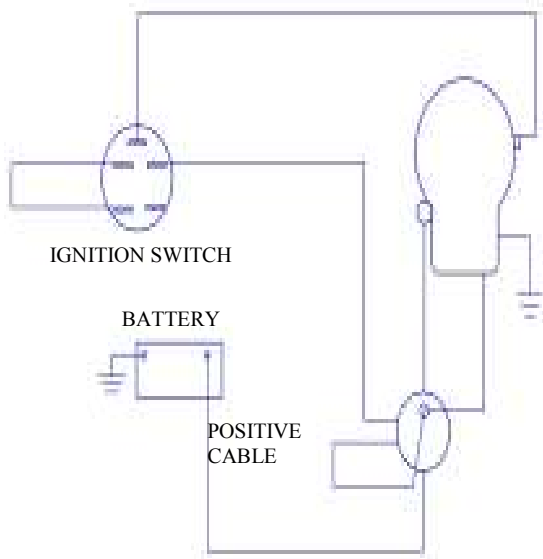

BRIGGS & STRATTON ENGINES

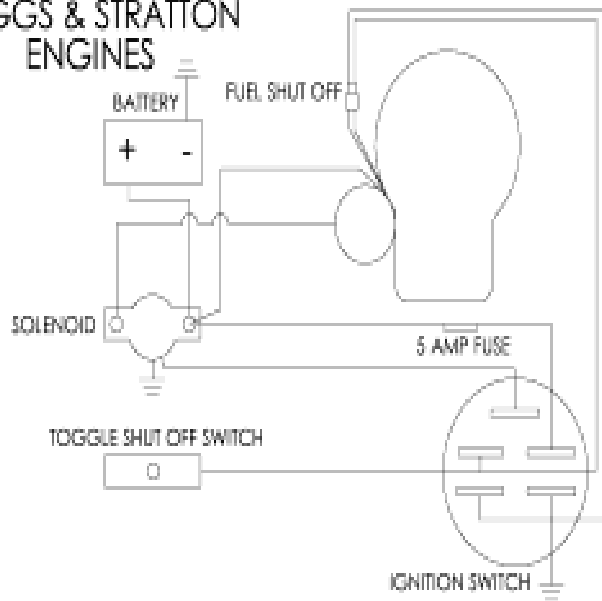



www.swisherinc.com

OWNER'S MANUAL

MODEL NO.

T1360B1

T1360T

T1360H

T1360K

T13560

RK1360

T14560

T17560

60" FINISH CUT TRAILMOWER

HOW TO ORDER REPAIR PARTS:

Each mower has its own model number. Each engine has its own model number. The model number for the mower will be found on the right hand side of the frame at the wheel bracket. The model number for the engine will be found on the top of the blower fan housing.

All mower parts listed herein may be ordered directly from Swisher Mower & Machine Co. Inc. or your nearest Swisher dealer.

All engine parts may be ordered from the nearest dealer of the engine supplied with your mower.

Color cannot be guaranteed on service parts.

WHEN ORDERING PARTS, PLEASE HAVE THE FOLLOWING INFORMATION AVAILABLE:

- * PRODUCT - T-60 TRAILMOWER
- * SERIAL NUMBER - _____
- * MODEL NUMBER - _____
- * ENGINE MODEL NUMBER - _____
TYPE - _____
- * PART NUMBER
- * PART DESCRIPTION

TELEPHONE - 1-800-222-8183

FAX - 1-660-747-8650

SWISHER MOWER & MACHINE CO. INC.

1602 CORPORATE DRIVE
WARRENSBURG, MO 64093

SWISHER MOWER & MACHINE CO. INC.