



MASSEY FERGUSON

AGCO



SNAPPER™

ATTACHMENT OPERATOR'S MANUAL

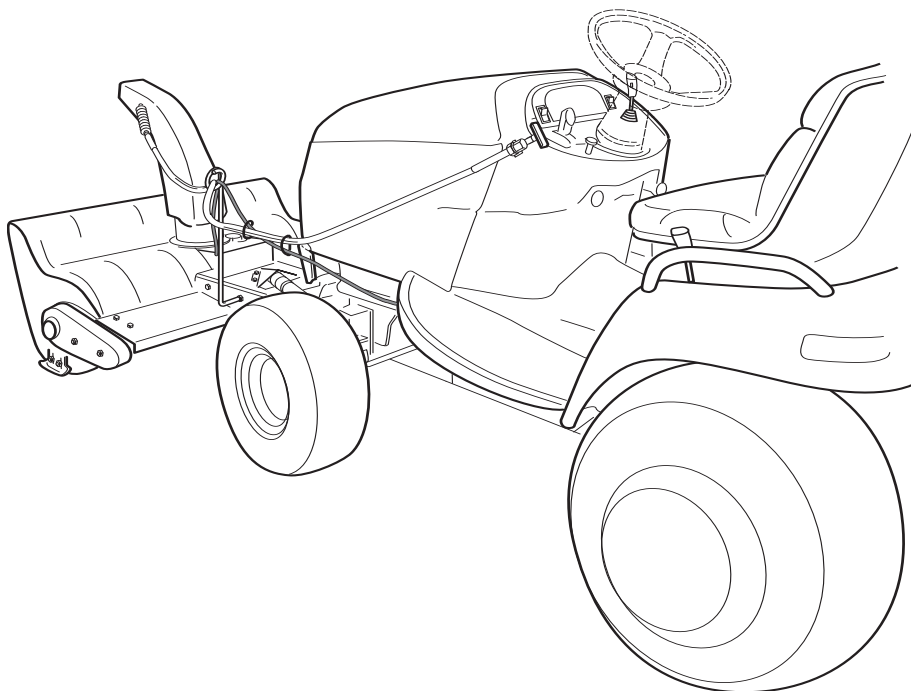

46" Single-Stage Snowthrower

46" Single-Stage Snowthrower

Mfg. No.	Description
1694403	46" Single Stage Snowthrower <i>(for use with Legacy XL / 2000 / 2900 Series)</i>

1725388

Revision 03

Rev. Date 04/2008

TP 100-3896-03-AT-SMAN



www.simplicitymfg.com



www.snapper.com

Briggs & Stratton Power Products Group, L.L.C.
Copyright © 2008 Briggs & Stratton Corporation
Milwaukee, WI USA. All Rights Reserved
www.BRIGGSandSTRATTON.com



www.AFCOLawn.com



www.MasseyLawn.com

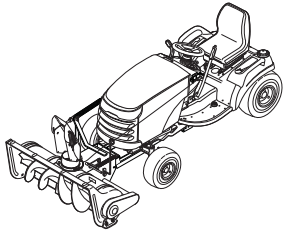

Table of Contents

Safety Rules & Information

Training	2
Preparation	2
Operation	2
Children	3
Clearing a Clogged Discharge Chute	3
Service, Maintenance and Storage	3
Emissions	3
Decals	4
Required Accessories	5
Recommended Accessories	5
Clean-Out Warning and Procedure	5

Operation

Controls	7
Checks Before Starting	7
Operating on Slopes	7
Transporting	8
Engine & Ground Speed Selection	8
Stopping & Starting	8
Snow Removal Suggestions	8
Daily Storage	8
Off Season Storage	8

Maintenance

Schedule for Normal Care	9
Lubricate Snowthrower	9
Drive Shaft Lubrication	10
Check Auger Gearbox Oil Level	10
Inspect Scraper Bar	10
Reversing Scraper Bar	10
Shear Bolts	11

Adjustment

Skid Shoe Adjustment	11
Electric Chute Rotator Gear	11

Troubleshooting, Adjustments & Service

Troubleshooting Chart	12
-----------------------------	----

Initial Installation

Install Front Hitch	13
Install Long Drive Shaft	14
Mount Cable Guide	15
Assemble Discharge Chute	15
Electric Chute Rotator	15
Attach Deflector Control Cable Support Arm	15
Attach Short Drive Shaft to Drive Chain Box	16
Secure Cables	16
Snowthrower Installation	17

Snowthrower & Hitch Removal

Snowthrower & Hitch Removal	19
-----------------------------------	----

Mounting Remote Deflector Control

Instructions	20
Template	21

Hardware Torque Specifications

Chart	22
-------------	----

NOTE: In these instructions, “left” and “right” are referred to as seen from the operating position.

Safety Rules & Information



This machine is capable to amputating hands and feet. Read these safety rules and follow them closely. Failure to obey these rules could result in loss of control of unit, severe personal injury or death to you, or bystanders, or damage to property or equipment. The triangle  in text signifies important cautions or warnings which must be followed.

TRAINING

1. Read, understand, and follow all instructions on the machine and in the manuals before operating this unit. Be thoroughly familiar with the controls and the proper use of the equipment. Know how to stop the unit and disengage the controls quickly.
2. Never allow children to operate the equipment. Never allow adults to operate the equipment without proper instruction.
3. Keep the area of operation clear of all persons, particularly small children and pets.

PREPARATION

1. Thoroughly inspect the area where the equipment is to be used and remove all doormats, sleds, boards, wires, and other foreign objects.
2. Disengage all clutches and shift into neutral before starting engine (motor).
3. Do not operate the equipment without wearing adequate winter outer garments. Avoid loose fitting clothing that can get caught in moving parts. Wear footwear that will improve footing on slippery surfaces.
4. Handle fuel with care; it is highly flammable.
 - (a) Use an approved fuel container.
 - (b) Never add fuel to a running engine or hot engine.
 - (c) Fill fuel tank outdoors with extreme care. Never fill fuel tank indoors. Replace fuel cap securely and wipe up spilled fuel.
 - (d) Never fill containers inside a vehicle or on a truck or trailer bed with a plastic liner. Always place containers on the ground, away from your vehicle, before filling.
 - (e) When practical, remove gas-powered equipment from the truck or trailer and refuel it on the ground. If this is not possible, then refuel such on a trailer with a portable container, rather than from a gasoline dispenser nozzle.
 - (f) Keep nozzle in contact with the rim of the fuel tank or container opening at all times, until refueling is complete. Do not use a nozzle lock-open device.
 - (g) Replace gasoline cap securely and wipe up spilled fuel.
 - (h) If fuel is spilled on clothing, change clothing immediately.
5. Adjust the collector housing height to clear gravel or crushed rock surfaces.
6. Never attempt to make any adjustments while the engine (motor) is running (except when specifically recommended by the manufacturer).
7. Let engine (motor) and machine adjust to outdoor temperatures before starting to clear snow.
8. Always wear safety glasses or eye shields during operation or while performing an adjustment or repair to protect eye from foreign objects that may be thrown from the machine.

OPERATION

1. Do not put hands or feet near or under rotating parts. Keep clear of the discharge opening at all times.
2. Exercise extreme caution when operating on or crossing gravel drives, walks, or roads. Stay alert for hidden hazards or traffic. Do not carry Passengers.
3. After striking a foreign object, stop the engine (motor), remove the wire from the spark plug, disconnect the cord on electric motors, thoroughly inspect the snowthrower for any damage, and repair the damage before restarting and operating the snowthrower.
4. If the unit should start to vibrate abnormally, stop the engine (motor) and check immediately for the cause. Vibration is generally a warning of trouble.
5. Stop the engine (motor) whenever you leave the operating position, before unclogging the collector/impeller housing or discharge guide, and when making any repairs, adjustments, or inspections.
6. When leaving the machine unattended, disengage the power take-off (PTO), lower the attachment, set the parking brake, stop the engine, and remove the key.
7. When cleaning, repairing, or inspecting make certain the collector/impeller and all moving parts have stopped. Disconnect the spark plug wire and keep the wire away from the plug to prevent accidental starting. Do not run the engine indoors except for starting the engine or for transporting the snowthrower in or out of the building. Open the outside doors; exhaust fumes are dangerous.
8. Exercise extreme caution when operating on slopes. Do not attempt to clear steep slopes.
9. Never operate the snowthrower without proper guards plates, or other safety protective devices in place and working.
10. Never direct the discharge toward people or areas where property damage can occur. Keep children and others away.
11. Do not overload the machine capacity by attempting to clear snow at too fast a rate.
12. Never operate the machine at high transport speeds on slippery surfaces. Look behind and use care when operating in reverse.
13. Disengage power to the collector/impeller when snowthrower is transported or not in use.
14. Use only attachments and accessories approved by the manufacturer of the snowthrower (such as wheel weights, counterweights, or cabs).
15. Never operate the snowthrower without good visibility or light. Always be sure of your footing, and keep a firm hold on the handles. Walk, never run.
16. Never touch a hot engine or muffler.
17. Never operate the snowthrower near glass enclosures, automobiles, window wells, drop-offs, and the like without proper adjustment of the discharge angle.
18. Never direct discharge at bystanders or allow anyone in front of the unit.
19. Never leave a running unit unattended. Always disengage the auger and traction controls, stop engine, and remove keys.

20. Do not operate the unit while under the influence of alcohol or drugs.
21. Keep in mind the operator is responsible for accidents occurring to other people or property.
22. Data indicates that operators, age 60 years and above, are involved in a large percentage of power equipment-related injuries. These operators should evaluate their ability to operate the unit safely enough to protect themselves and others from injury.
23. DO NOT wear long scarves or loose clothing that could become entangled in moving parts.
24. Snow can hide obstacles. Make sure to remove all obstacles from the area to be cleared.
8. Always follow the engine manual instructions for storage preparations before storing the unit for both short and long term periods.
9. Always follow the engine manual instructions for proper start-up procedures when returning the unit to service.
10. Maintain or replace safety and instruction labels as necessary.
11. Keep nuts and bolts tight and keep equipment in good condition.
12. Never tamper with safety devices. Check their proper operation regularly and make necessary repairs if they are not functioning properly.
13. Components are subject to wear, damage, and deterioration. Frequently check components and replace with manufacturer's recommended parts, when necessary.

CHILDREN

Tragic accidents can occur if the operator is not alert to the presence of children. Children are often attracted to the unit and the operating activity. Never assume that children will remain where you last saw them.

1. Keep children out of the area and under the watchful care of another responsible adult.
2. Be alert and turn unit off if children enter the area.
3. Never allow children to operate the unit.
4. Use extra care when approaching blind corners, shrubs, trees, or other objects that may obscure vision.

CLEARING A CLOGGED DISCHARGE CHUTE

Hand contact with the rotating impeller inside the discharge chute is the most common cause of injury associated with snowthrowers. Never use your hand to clean out the discharge chute.

To clear the chute:

1. SHUT OFF THE ENGINE.
2. Wait 10 seconds to be sure the impeller blades have stopped rotating.
3. Always use a clean out tool, not your hands.

SERVICE, MAINTENANCE, AND STORAGE

1. Check shear bolts and other bolts at frequent intervals for proper tightness to be sure the equipment is in safe working condition.
2. Never store the machine with fuel in the fuel tank inside a building where ignition sources are present such as hot water and space heaters, or clothes dryers. Allow the engine to cool before storing in any enclosure.
3. Always refer to the operator's manual for important details if the snowthrower is to be stored for an extended period.
4. Maintain or replace safety and instruction labels as necessary.
5. Run the machine a few minutes after throwing snow to prevent freeze-up of the collector/impeller.
6. If fuel is spilled, do not attempt to start the engine but move the machine away from the area of spillage and avoid creating any source of ignition until fuel vapors have dissipated.
7. Always observe safe refueling and fuel handling practices when refueling the unit after transportation or storage.

EMISSIONS

1. Engine exhaust from this product contains chemicals known, in certain quantities, to cause cancer, birth defects, or other reproductive harm.
2. If available, look for the relevant Emissions Durability Period and Air Index information on the engine emissions label.

Safety Decals

SAFETY DECALS

This unit has been designed and manufactured to provide you with the safety and reliability you would expect from an industry leader in outdoor power equipment manufacturing.

Although reading this manual and the safety instructions it contains will provide you with the necessary basic knowledge to operate this equipment safely and effectively, we have placed several safety labels on the unit to remind you of this important information while you are operating your unit.

All DANGER, WARNING, CAUTION and instructional messages on your unit should be carefully read and obeyed. Personal bodily injury can result when these instructions are not followed. The information is for your safety and it is important! The safety decals below are on your unit.

If any of these decals are lost or damaged, replace them at once. See your local dealer for replacements.

These labels are easily applied and will act as a constant visual reminder to you, and others who may use the equipment, to follow the safety instructions necessary for safe, effective operation.



Part No. 1722674
Discharge Chute Danger Decal



Part No. 1709688
Auger Danger Decal



Part No. 1716532
Auger Danger Decal



Part No. 1709689
Auger Danger Decal



Part No. 1716540
Wheel Weights Required Decal



Part No. 1716531
Main Operation Warning Decal

Required Accessories

It is required that tire chains and two rear wheel weights or Quick Tach Weights are used.

Never operate on slopes greater than 17.6% (10°).

Recommended Accessories

A rear-mounted weight box can also be added for additional traction. The maximum weight added to the tractor should not exceed 35 lbs. per wheel, plus 100 additional pounds in the rear weight box.

For operation on slopes greater than 15% (8.5°), Quick Tach Weights, tire chains, and wheel weights are recommended. **Never operate on slopes greater than 17.6% (10°).**

Required Accessories

A Lift Lever Kit is required for some of the models covered by this manual, and must be installed as part of hitch installation.



TRACTOR CONTROLS

Before you begin operating the tractor and attachment, make certain you have:

- **Read and understood the instructions in the tractor Operator's Manual.**
- **Become thoroughly familiar with all of the tractor controls and their operation, including how to safely and properly start and stop the unit.**
- **Practice driving in an open area, without the attachment, to become accustomed to the unit.**

DANGER

Do not clean out discharge chute with hands. Contact with moving parts inside chute will cause serious injury. Use a clean out tool. Use the following procedure to remove objects or clear the chute:

1. Stop the engine. Remove the key
2. Wait 10 seconds to be sure the auger/impeller blades have stopped rotating.
3. Always use a clean-out tool. **DO NOT** use your hands.

OPERATION

Controls

Read and understand the instructions in your tractor Operator's Manual.

Refer to Figure 1 for control locations.

A. ELECTRIC CHUTE ROTATOR

Rotates the chute right and left.

B. PTO SWITCH

Engages and disengages the snowthrower.

C. ATTACHMENT LIFT

Raises and lowers the snowthrower for transport.

D. PTO SELECTOR

Selects front, rear or both PTO's. Select forward position for snowthrower use.

E. THROTTLE

Sets engine speed. Always use FULL throttle.

F. HYDRAULICS SELECTOR SWITCH

Selects inboard or auxiliary hydraulics. Select forward position.

G. REMOTE DEFLECTOR CONTROL

Sets and locks in the angle of the chute deflector.

Checks Before Starting

1. Refer to the Maintenance & Adjustments section of this manual and perform any needed service. Also, refer to the tractor Operator's Manual and perform any required service.
2. Remove any objects from the work area which might be caught in, or thrown by the auger.
3. Before starting the engine, clear the auger of any ice which may cause damage to the unit.
4. Adjust the deflector and skid shoes to desired height. See Skid Shoe Adjustment.
5. Make sure all hardware is present and secure.

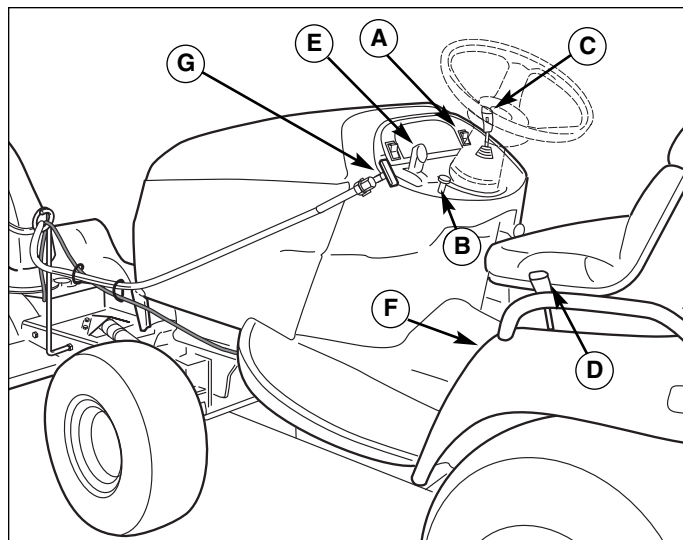

Figure 1. Controls

- | | |
|---------------------------|-----------------------------|
| A. Electric Chute Rotator | E. Throttle |
| B. PTO Switch | F. Hydraulics Selector |
| C. Attachment Lift | G. Remote Deflector Control |
| D. PTO Selector | |

Operating On Slopes

⚠ WARNING

- Never operate on slopes greater than 17.6% (10°), which is a rise of three feet (.9m) vertically in 10 feet (3.1m) horizontally.
- When operating on slopes wheel weights and tire chains are required.
- Select slow ground speed before driving onto a slope. Avoid using brakes to control speed.
- Drive up and down the face of the slopes, never across the slope face.
- Use caution when changing directions and **DO NOT START OR STOP ON A SLOPE.**

⚠ WARNING

Perform the Safety System Interlock test found in your tractor Operator's Manual. If tractor does not pass the test, do not operate the tractor. See your authorized dealer. Under no circumstances should you attempt to defeat the safety system.

Operation

IMPORTANT NOTE

Always raise the snowthrower before turning or backing up, to prevent damage to the unit.

Transporting

1. Disengage the electric clutch and then raise the snowthrower.
2. Adjust ground speed according to surface conditions.
3. Select a low ground speed when transporting on a slippery surface.

Engine & Ground Speed Selection

Always run the engine at full throttle.

Normally, a slow ground speed is best for throwing snow. The deeper or heavier the snow, the slower the recommended ground speed.

Starting & Stopping

1. Start the tractor engine. Set engine throttle at full speed.
2. Lower the snowthrower.
3. Engage the electric clutch switch. Snowthrower auger should rotate. Disengage the electric clutch switch. Snowthrower auger should stop.

WARNING

If auger does not start and stop when engaging/disengaging electric clutch, see your authorized dealer. Under no circumstances should you attempt to defeat the safety system.

4. Select the proper ground speed.
5. To stop the tractor, depress the clutch/brake pedal. To stop the snowthrower, disengage the electric clutch. Before leaving the seat, stop the engine, disengage the electric clutch, set the parking brake, remove the key, and wait for all moving parts to stop.

Snow Removal Suggestions

- Determine the best snow removal pattern before beginning.
- Wind direction is an important factor to consider. Rotate the spout to discharge snow downwind.
- Plan the pattern so that you avoid throwing snow on cleared areas and on yourself as you are operating.
- When land contour permits, it is best to travel in the longest direction to minimize turning.
- In very deep or heavy snow, it may be necessary to make the first pass with snowthrower partially raised, backing up every few feet and lowering the snowthrower to clear the snow left on the surface. Also, it may be necessary to slice off less than the full width of the auger or reduce ground speed.
- If snow stops flowing freely from the spout, back away until the snowthrower clears itself.

DANGER

If the auger stalls or the chute plugs, DISENGAGE THE ELECTRIC CLUTCH, STOP THE ENGINE AND REMOVE THE KEY. SET THE PARKING BRAKE. WAIT FOR MOVING PARTS TO STOP. Remove the foreign object or clear the spout with a piece of wood before restarting the engine. Never place hands into auger housing or spout to clear jammed object. Auger may rotate when object is removed.

Daily Storage

1. Run the snowthrower a few minutes after blowing snow to prevent freeze-up of auger.
2. Allow tractor engine to cool before storing in any enclosure.

Off-Season Storage

1. Remove snowthrower from the tractor. Hitch can remain installed if other attachments are to be used.
2. Use water pressure or a brush to thoroughly clean the housing.
3. Paint, or lightly coat with oil, any area where paint has been worn or chipped away.
4. Lubricate the snowthrower.
5. Store the snowthrower and hitch in a dry place.

DANGER

To prevent an explosion or fire, never store the tractor with fuel in the tank inside a building where an ignition source is present.

MAINTENANCE

Schedule For Normal Care

Care Required	Schedule
Clean snow and ice from snowthrower.	After each use.
Lubricate snowthrower.	Every 10 hours or at least once a year.
Inspect, adjust and lubricate drive chain. Check Gear Box Oil	Once a year or more often under frequent use.

Inspect, Adjust, & Lubricate Drive Chain

See Figure 3.

1. Remove the two flange nuts (A) and chain guard (B).
2. Check the chain. Replace chain if worn or damaged.
3. There should be no slack in the chain, and the sprockets (D and G) should be aligned. The drive shaft (I) should be parallel with the auger housing. If adjustment is required proceed with steps 4 - 7.
4. Loosen the adjustment nuts (F).
5. Pull rearward on the drive shaft (I) until all slack is removed from chain. With drive shaft housing parallel with auger housing, and sprockets aligned, retighten the adjustment nuts (F). Torque to 40-50 ft. lbs.
6. Spread a coat of grease on the chain, working the grease into the links.
7. Reinstall the chain guard (B) and two nuts (A).

Lubricate the Auger

Lubricate the auger as shown in Figure 4.

Lubricate Discharge Chute

Lubricate the ring gear at the base of the discharge chute with lithium grease. Lubricate the deflector hinge, extension linkage, and cable with oil (see Figure 2).

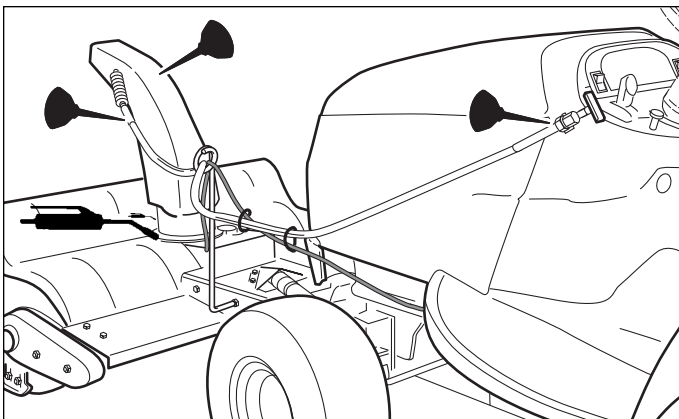

Figure 2. Lube Discharge Chute

⚠ WARNING

To avoid serious injury, perform maintenance on the tractor or snowthrower only when the engine is stopped, parking brake is set and all moving parts have stopped. Always remove the ignition key before beginning maintenance or adjustments to prevent accidental starting of the engine.

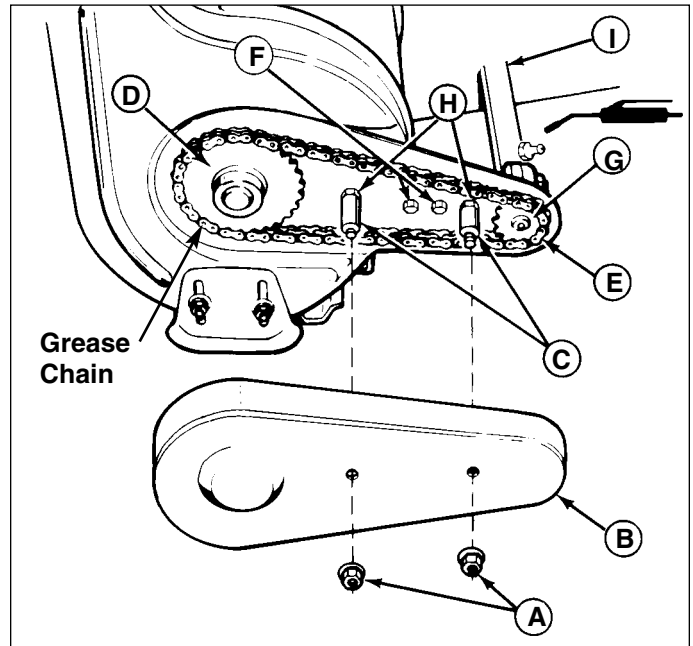

Figure 3. Drive Chain

- | | |
|-------------------|-------------------------|
| A. Flange Nuts | F. Adjustment Nuts |
| B. Chain Guard | G. Drive Shaft Sprocket |
| C. Spacers | H. Nuts |
| D. Auger Sprocket | I. Drive Shaft |
| E. Drive Sprocket | |

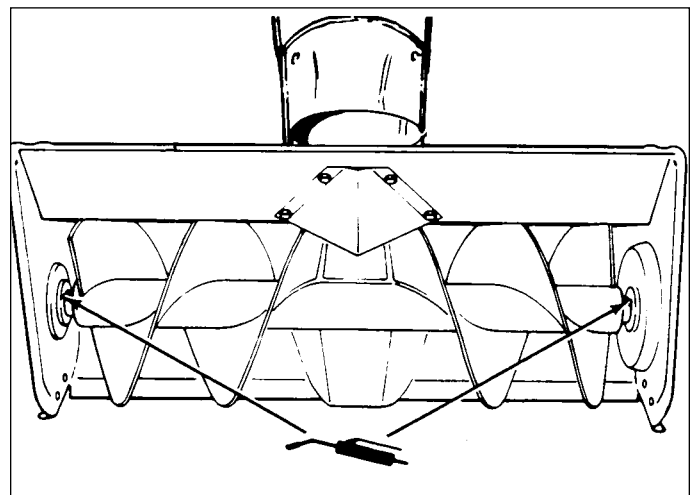

Figure 4. Lubricate Auger

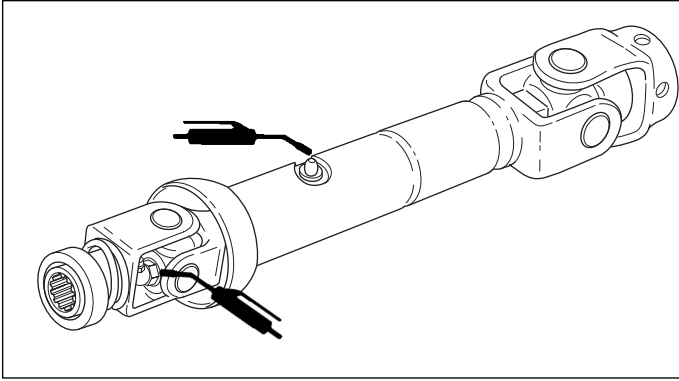

Figure 5. Drive Shaft Lubrication

Drive Shaft Lubrication

Lubricate the universal joints at both ends of the snowthrower drive shaft with lithium grease. Also lubricate the grease zerk in the middle of the shaft (see Figure 5).

Check Gear Box Oil

1. Remove and retain the four capscrews, lockwashers, and flange nuts (A, Figure 6) securing the gear box plate.
2. Rotate the gear box to access the top fill plug (see Figure 8).
3. Remove the fill plug using a 1/4" Allen wrench.
4. Access the back level plug through the oblong hole in the top of the snowthrower (see Figure 7).
5. Remove the plug using a 1/4" Allen wrench.
6. While holding the gear box level, add Simplicity Winter Weight Worm Gear Oil to the fill hole until oil runs out the level hole.
7. Reinstall the fill plug and level plug.
8. Pivot the gear box back into position and secure the plate using the hardware removed in step 1.

Inspect Scraper Bar

1. Raise snowthrower to highest position.
2. Use safety block(s) to secure snowthrower:
 - a. Place safety block under attachment.
 - b. Lower attachment until it rests on block(s).
3. Inspect location where scraper bar (A, Figure 9) meets snowthrower housing.

Reversing Scraper Bar

1. Raise attachment to top height.
2. Place safety blocks under attachment.
3. Lower attachment until it rests on blocks.
4. Using 1/2" wrench remove six nuts, washers, and bolts (B, Figure 6).
5. Remove scraper bar (A, Figure 9).
6. Reverse or replace scraper bar.
7. Replace the six bolts, washers, nuts and tighten.

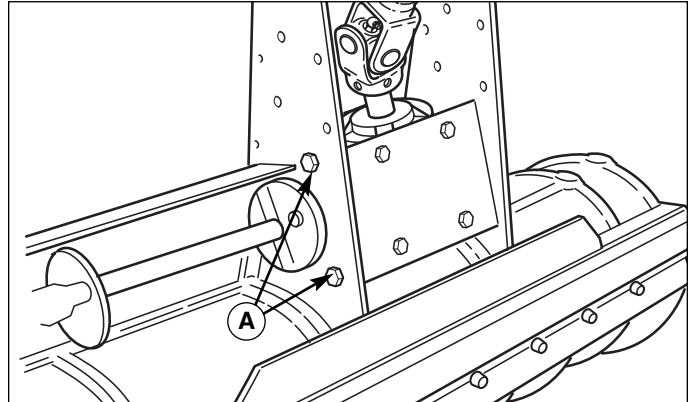

Figure 6. Remove Plate Hardware
A. Capscrew, Lockwasher & Flange Nut

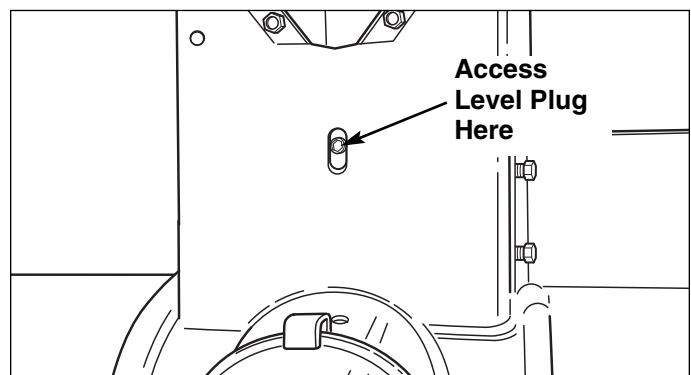

Figure 7. Level Plug Location

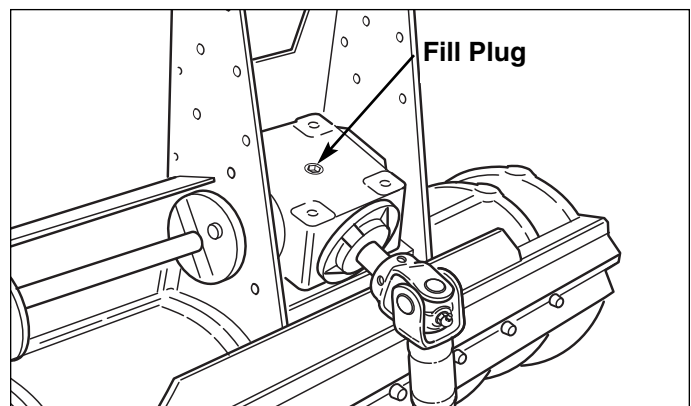

Figure 8. Fill Plug Location

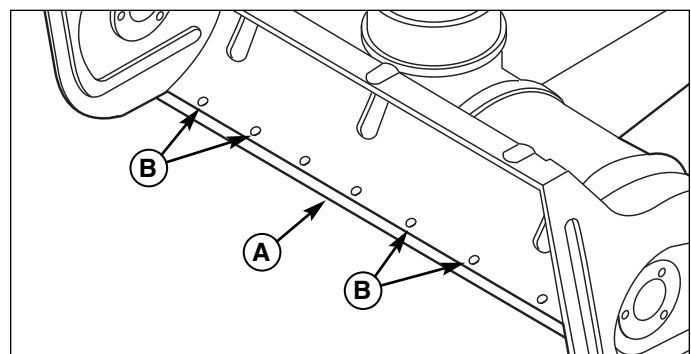

Figure 9. Scraper Bar Adjustment
A. Scraper Bar B. Mounting Hardware

Shear Bolts

Refer to Figure 10 for discharge fan shear bolt, two stage only (grade 5 hardness, 1/4" x 1"). Refer to Figure 11 for auger shear bolt, all models (one in each auger-specialized, grade 5 hardness, 5/16" x 2-1/2").

Check for excessive wear. The shear bolt will break if the auger or fan hits a solid object. If this happens:

1. Stop the snowthrower and tractor immediately.
2. Stop the engine, lock the parking brake, and remove the key.
3. Remove the broken shear bolt.
4. Install a new shear bolt. Make sure the replacement shear bolt is Grade 5 hardness.
5. Locate and correct the cause of the shearing.

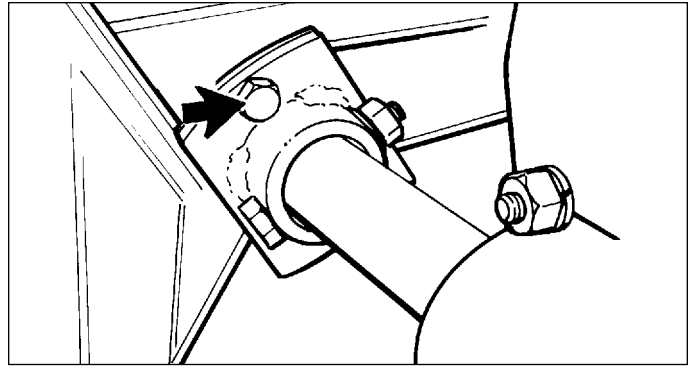

Figure 10. Discharge Fan Shear Bolt (Two Stage)

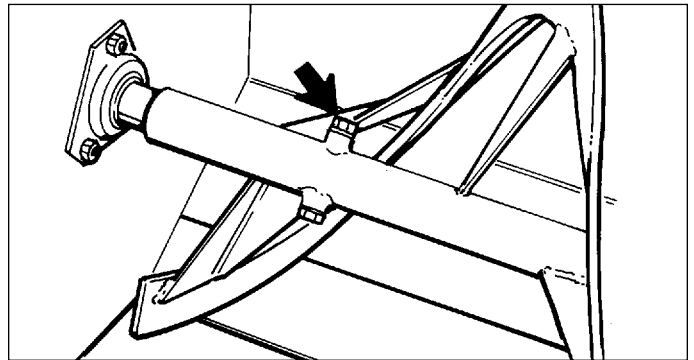

Figure 11. Auger Shear Bolt

ADJUSTMENTS

Skid Shoe Adjustment

On smooth surfaces such as concrete or asphalt, the scraper bar should scrape the surface. On surfaces such as gravel, the scraper bar should be set high enough so that it will not pick up debris.

1. Loosen the nuts securing the skid shoes (see Figure 12).
2. Raise or lower the scraper bar to the desired height. Use wood blocks to hold the snowthrower in position.
3. Set the skid shoes so that they are in contact with the ground and tighten the skid shoe nuts.

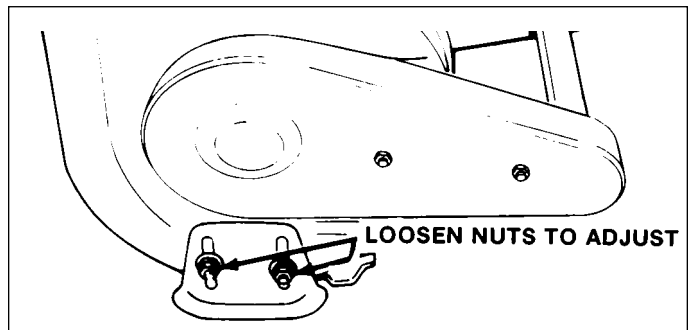

Figure 12. Adjusting Skid Shoes

Electric Chute Rotator Gear

1. Remove the plastic cover (B, Figure 13) and loosen the three taptite screws (A) securing the electric spout rotator motor.
2. Adjust the motor so that it meshes with the discharge chute ring gear and tighten the adjustment screws (A).

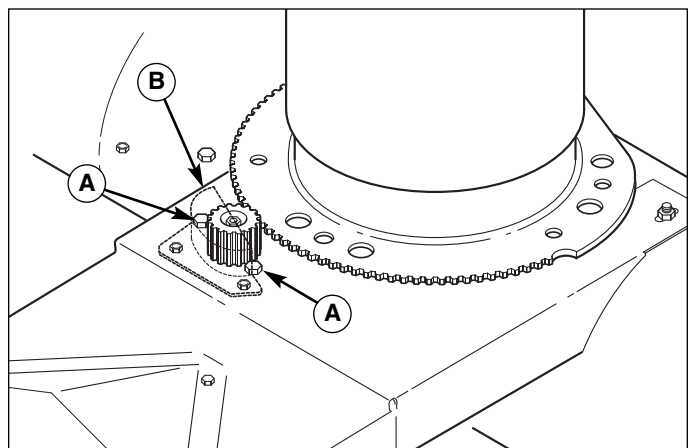

Figure 13. Discharge Chute Motor Gear Adjustment
A. Adjustment Screws B. Plastic Cover

Troubleshooting

Locate the problem you've encountered in the chart below. Check the possible causes one at a time in the order listed. Correct any problems that are found and operate the snowthrower to see if you have eliminated the problem.

⚠ WARNING

To avoid serious injury, perform maintenance on the tractor or snowthrower only when the engine is stopped, parking brake is set, and all moving parts have stopped. Always remove the ignition key before beginning maintenance or adjustments to prevent accidental starting of the engine.

PROBLEM	POSSIBLE CAUSE	CORRECTIVE ACTION
Blower does not	PTO Selector in wrong position.	Put selector in forward position.
Blower does not lift	Hydraulics Selector in wrong position.	Switch to forward position.
Auger does not rotate.	Broken shear bolt.	Replace shear bolt.
	Faulty auger gearbox.	See your dealer.
Snowthrower vibrates excessively.	Faulty bearings (gearbox, auger or discharge fan).	See your dealer.
	Auger or discharge fan bent or broken.	See your dealer.
	Faulty auger gearbox.	See your dealer.
Uneven cut on bottom of blower.	Scraper bar is worn back to blower housing.	Replace or reverse scraper bar.
Uneven cut on bottom of blower.	Skid shoes out of adjustment.	Check and adjust shoes accordingly.
Discharge chute does not rotate.	Discharge chute not lubricated.	Lubricate discharge chute.
	Something is caught in discharge fan.	Inspect and remove foreign material with engine off and all motion stopped.
	Electric Motor defective.	See your dealer.

INITIAL INSTALLATION

Follow the instructions for the sub-frame kit.

Install Front Hitch

1. Lift assembly (C, Figure 14) and slide onto slots on tractor (D). Lift back of assembly to frame and install clevis pins (B), clevis pins (F) and hair pins (A).

Many approved attachments have color coded quick couplers to aid in installation. Match the tractor quick coupler with the like colored attachment quick coupler.

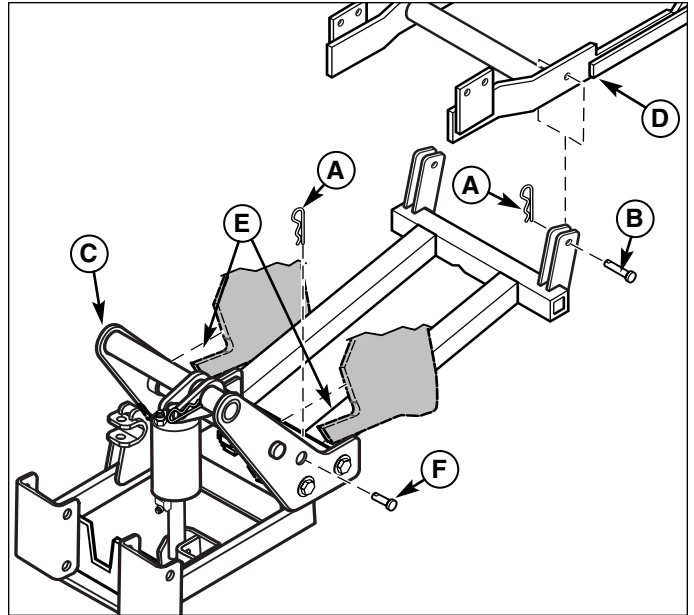

Figure 14. Hitch to Tractor Installation

A. Hair Pin

D. Sub-frame

B. Clevis Pin, 5/8 x 1-13/16

E. Slots on Tractor

C. Assembly

F. Clevis Pin, 5/8 x 2-1/2

Initial Installation

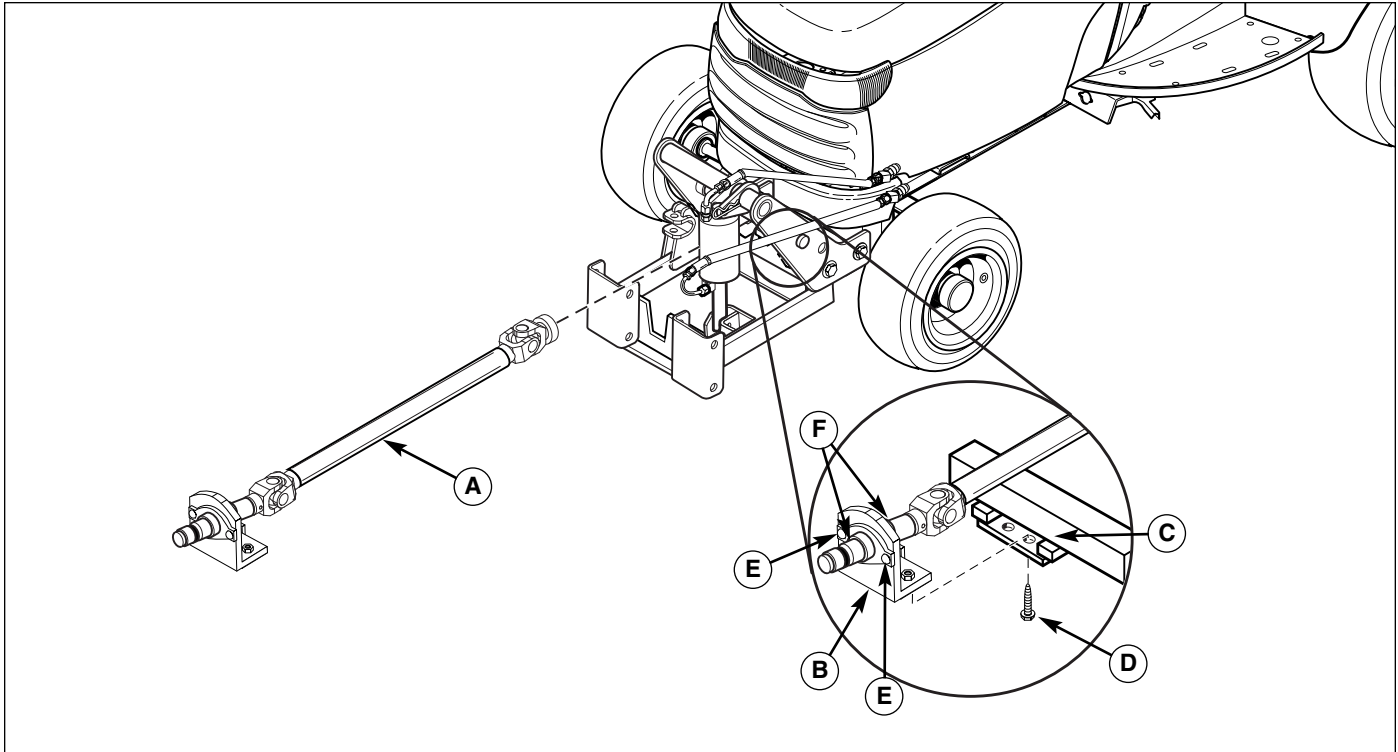

Figure 15. Front Hitch Mounting Brackets

- A. Drive Shaft
- B. Support Bracket
- C. Front Hitch
- D. Capscrews, 3/8-16 x 3/4
- E. Carriage Bolts & Nuts
- F. Set Collars

INSTALL LONG DRIVE SHAFT

1. Slide the drive shaft (A, Figure 15) in from the front. Line up the support bracket (B) with the front hitch (C). Simultaneously line up the the locking collar of the drive shaft (A, Figure 16) with the PTO drive of the transmission (B).
2. Slide the support bracket (B, Figure 15) in to the front hitch (C) about 1/2". Connect the locking collar (A, Figure 13). Pull back on the locking collar (A) and slide the drive shaft fully onto the transmission (B). Release the locking collar and pull back on the drive shaft until the locking collar locks onto the shaft.
4. Slide the support bracket (B, Figure 15) all the way into the front hitch (C). The support bracket (B) should be touching the front hitch. Tighten cap-screws (D).

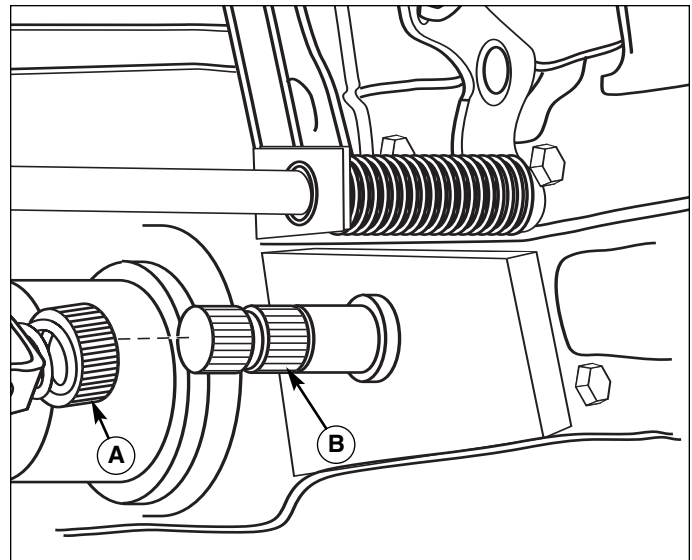

Figure 16. Attachment Lift Extension
A. Drive Shaft Locking Collar
B. Transmission Shaft

NOTE: If the support bracket does not touch the front hitch loosen the set collars (F), carriage bolts and nuts (E) holding the bearing holders. Slide the bracket to the front hitch (C) and tighten the set collars (F), carriage bolts and nuts (E). Secure the bracket with the cap-screws (D).

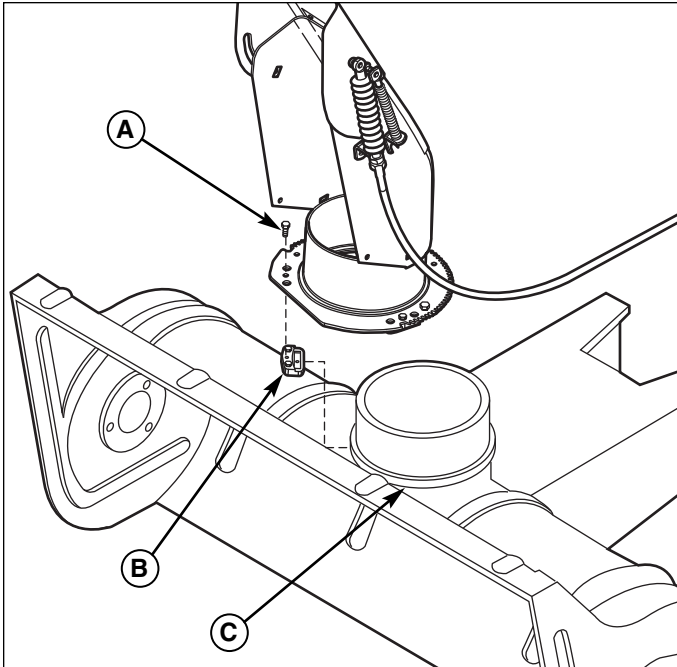

Figure 17. Assemble Discharge Chute

- A. Plastite Screw
- B. Hold-Down
- C. Chute Ring

Assemble Discharge Chute

1. Remove the three hold downs (B, Figure 17) and plastite screws (A).
2. Lubricate the base of the discharge chute and ring gear with automotive lithium grease.
3. Remove the plastic cover (B, Figure 18) and loosen the three taptite screws (A) securing the electric spout rotator motor.
4. Install the discharge chute and secure to the chute ring (C, Figure 17) using the three hold downs (B) and plastite screws (A).
5. Adjust the motor so that it meshes with the discharge chute ring gear and tighten the adjustment screws (A, Figure 18).

Install Skid Shoes

1. Install the skid shoes using 3/8-16 x 3/4" carriage bolts, washers, lockwashers, and nuts as shown in Figure 19.
2. Adjust the skid shoes. See Adjustments section.

Electric Chute Rotator Gear

1. Remove the plastic cover (B, Figure 18) and loosen the three taptite screws (A) securing the electric spout rotator motor.

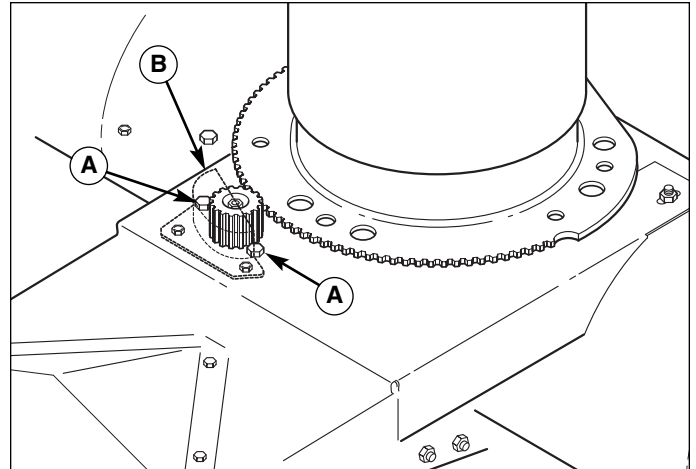

Figure 18. Discharge Chute Motor Adjustment
A. Adjustment Screws B. Plastic Cover

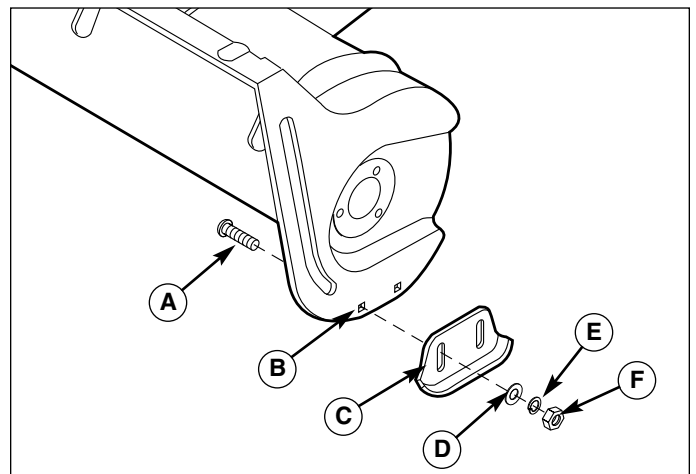

Figure 19. Skid Shoe Installation

- A. Carriage Bolt, 3/8-16 x 3/4"
- B. Snowthrower Housing
- C. Skid Shoe
- D. Washer
- E. Lockwasher
- F. Hex Nut

2. Adjust the motor so that it meshes with the discharge chute ring gear and tighten the adjustment screws (A).

Attach Deflector Control Cable Support Arm

1. Assemble the deflector control cable support arm (A, Figure 22) to the left side of the snowthrower using one 5/16-18 x 1" capscrew, lockwasher, and nut using the holes (B) shown in Figure 22.

Initial Installation

Attach Short Drive Shaft to Drive Box

1. Grease the drive shaft coupler and chain box input shaft.
2. Install the key (A, Figure 20) into the input shaft key-way.
3. Attach the drive shaft to the input shaft (see Figure 20).
4. Secure the drive shaft using a 1/4-20 x 1-7/8" cap-screw (D, Figure 20) and center-lock nut (B).

NOTE: The 1/4-20 x 1-7/8 capscrew supplied in the hardware bag has been ground to exactly 1-7/8 length for this purpose and is required for correct drive shaft clearance.

5. Secure the key with an hex socket set screw (C, Figure 20).

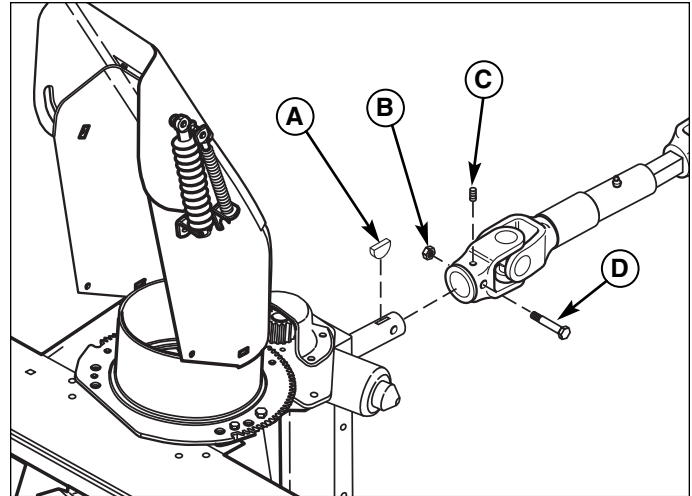

Figure 20. Install Drive Shaft

- A. Key** **C. Set Screw**
B. Nut, Centerlock, 1/4-20 **D. Capscrew, 1/4-20 x 1-7/8**

Secure Cables

DRILL REMOTE DEFLECTOR CONTROL MOUNTING BRACKET HOLES

NOTE: Perform the following procedure after the snowthrower is completely installed for the first time.

1. Using the template included in the back of this manual, drill two 9/32" holes in the dashboard to mount the remote deflector control bracket (C, Figure 21). See template at the back of this book for instructions.

SECURE REMOTE DEFLECTOR CONTROL CABLE

NOTE: Perform the following procedure after the snowthrower is completely installed for the first time.

1. Insert the deflector control handle (B, Figure 21) into the mounting bracket (C).
2. Route the remote deflector control cable and spout rotator motor wires through the cable guide (A, Figure 22).
3. Secure the handle (B, Figure 21) using a clevis pin (A) and hair pin clip (D).

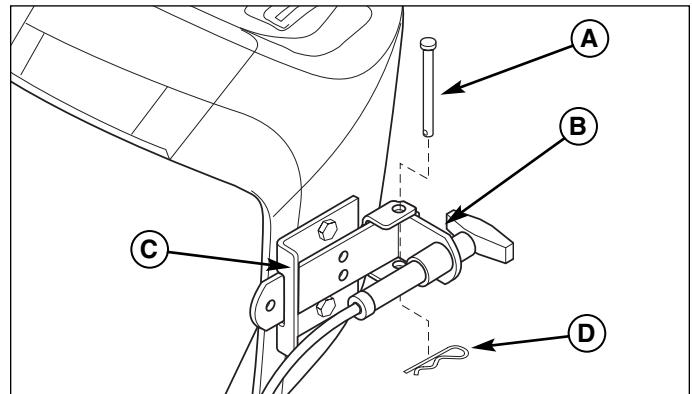

Figure 21. Install Remote Deflector Control

- A. Clevis Pin** **C. Mounting Bracket**
B. Deflector Control Handle **D. Hair Pin Clip**

SECURE SPOUT ROTATOR WIRE HARNESS

NOTE: Perform the following procedure after the snowthrower is completely installed for the first time.

1. Secure the spout rotator wire harness to the remote deflector control cable as shown in Figure 22 using cable ties (C).

Connect Electric Chute Rotator Wire Harness

1. Connect the electric discharge chute rotator motor leads to the wire harness. Route the wire harness through the control cable support arm (see Figure 22).

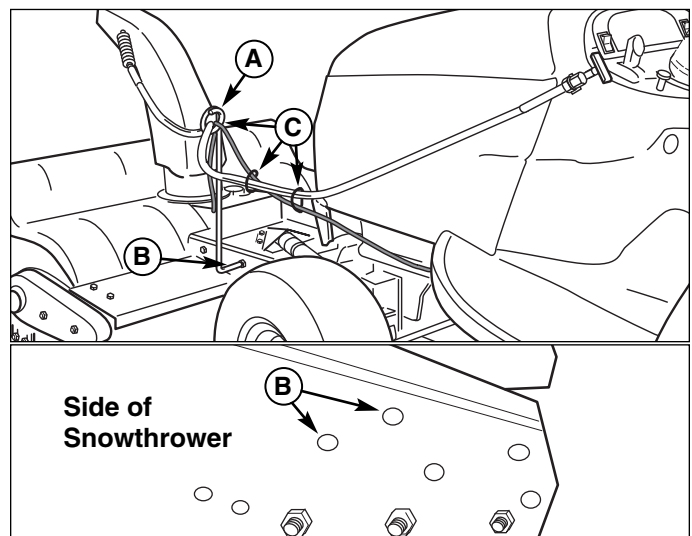

Figure 22. Deflector Control Cable Support Arm

- A. Cable Guide** **C. Cable Ties**
B. Holes in Snowthrower

SNOWTHROWER INSTALLATION

1. Fully lower the attachment lift.
2. See Figure 23. Pull the shot pins (B) open and locking them in open position.
3. Raise and support PTO shaft with a wire or rope.
4. See Figure 24. Drive the tractor push bar under the snowthrower hitch point (B). The dozer snowthrower hitch points (B) need to line up side to side with the edges of the push bar (A). The snowthrower hitch points (B) will hang from the top edge of the push bar (A). Slowly lift the snowthrower 1/2 inch off the ground.
5. See Figure 23. Place snowthrower shot pins (A) in closed position.
6. Make sure that PTO shaft is aligned with reduction box input shaft. This is done to prevent PTO shaft from interfering with connection point and to help align the shaft for hookup.
7. Stop engine, lock parking brake and remove key.
8. Check that shot pins (Figure 23) are fully seated into push bar (A, Figure 24). If the shot pins do seat all the way in the in (A, Figure 23) position repeat steps 1-8.
9. See Figure 25. Attach the drive shaft. Pull back on the locking collar (A) and slide the drive shaft fully onto the snowthrower. Release the locking collar and pull back on the drive shaft until the locking collar locks onto the shaft.
10. See Figure 26. Attach the electric chute rotator to the tractor attachment plug.

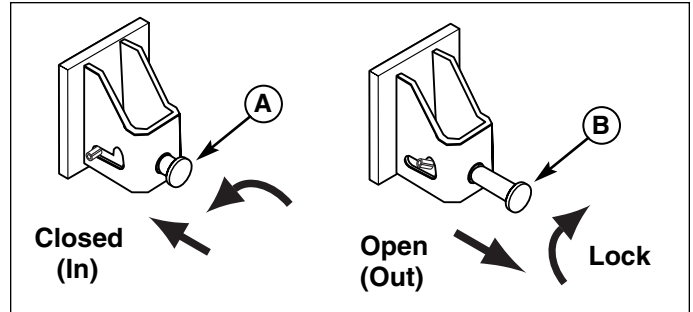

Figure 23. Shot Pins
A. Shot Pin (Closed)
B. Shot Pin (Open)

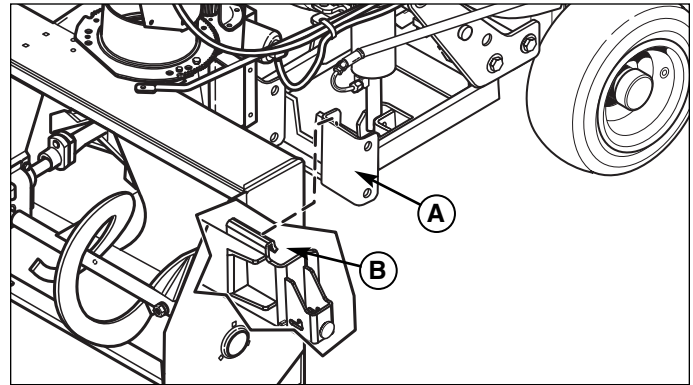

Figure 24. Attaching the Snowthrower to the Hitch
A. Push Bar
B. Hitch Point

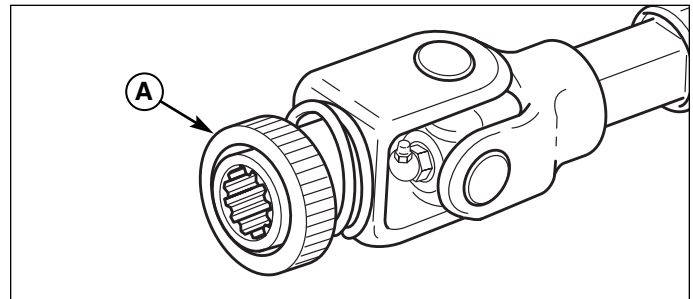

Figure 25. Attach Drive Shaft
A. Locking Collar

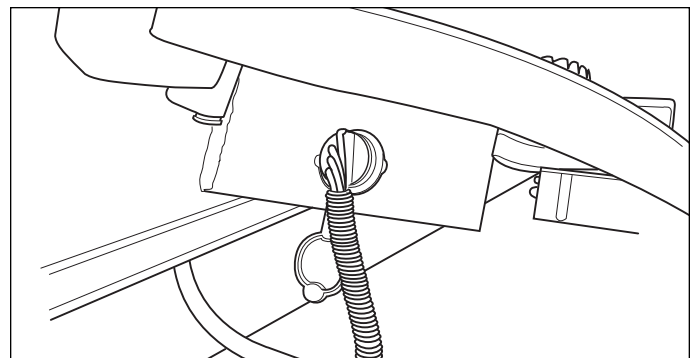

Figure 26. Attachment Electrical Connection

Snowthrower Installation

11. See Figure 27. Insert the deflector control handle (B) into the mounting bracket (C).

Route the remote deflector control cable and spout rotator motor wires through the cable guide (Figure 28).

Secure the handle (B, Figure 27) using a clevis pin (A) and hair pin clip (D).

NOTE: If the mounting holes have not been drilled in the dashboard see Drill Remote Deflector Control Mounting Holes under INITIAL INSTALLATION.

12. Lubricate the snowthrower as shown in the Maintenance section.
13. Perform all adjustments as shown in the Adjustments section.

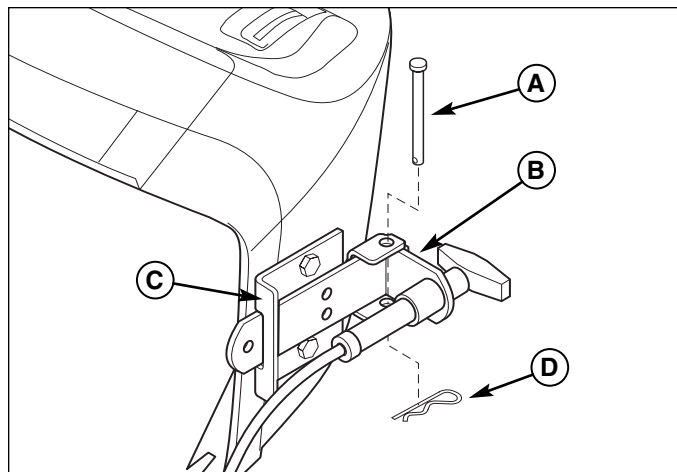

Figure 27. Install Remote Deflector Control
A. Clevis Pin
B. Deflector Control Handle
C. Mounting Bracket
D. Hair Pin Clip

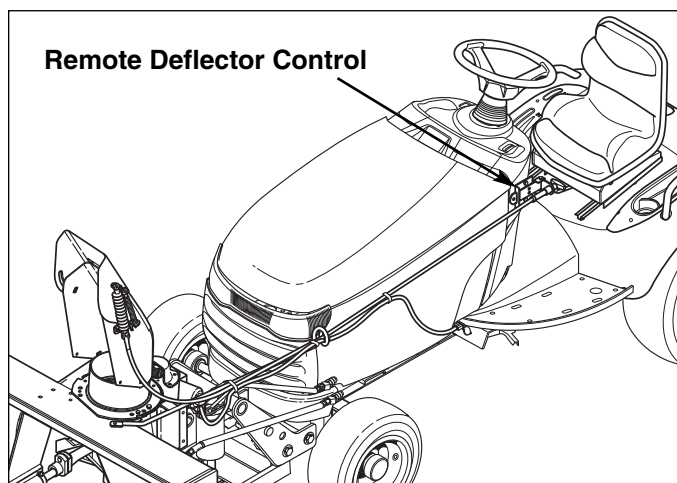

Figure 28. Cable and Wire Routing

SNOWTHROWER & HITCH REMOVAL

NOTE: Whenever removed, install clevis pins, hitch pins, clips and hardware onto snowthrower and hitch for storage.

1. Fully lower the attachment lift.
2. See Figure 25. Disconnect the drive shaft by pulling back on the locking collar (A) and then pulling the shaft off.
3. See Figure 26. Disconnect the attachment electrical connection.
4. See Figure 27. Remove the hardware securing the remote deflector control, and remove the control.
5. See Figure 23. Detach the snowthrower from the snowthrower hitch by moving the shot pins (B) into open position.
6. Lower the snowthrower to the ground and back out.
7. See Figure 15 & 16. Disconnect the drive shaft (A, Figure 15) from the transmission (B, Figure 16) by pulling on the locking collar (A). Slide the drive shaft out from the front of the tractor. The drive shaft may remain attached to the hitch assembly for storage.
8. See Figure 14. Disconnect hydraulic hoses. Disconnect hairpins (A) and remove clevis pins (B). Slide hitch assembly (C) off of the slots on the tractor (E).

Mount Remote Deflector Control

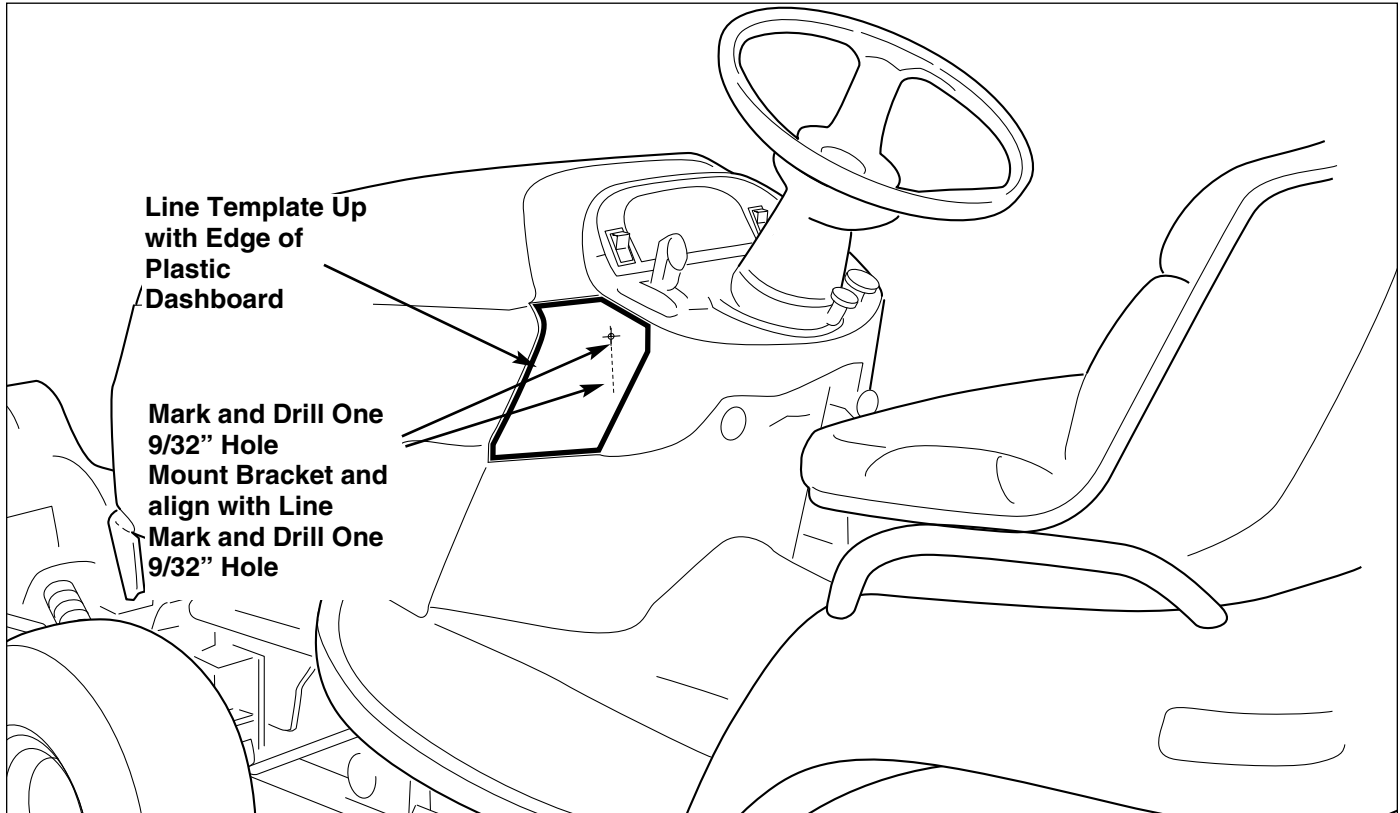

Figure 28. Template Location

MOUNTING REMOTE DEFLECTOR CONTROL

NOTE: Read through instructions before beginning.

1. Open the hood.
2. Cut out the template and place it on the lower left corner of the dashboard as shown above.
3. Mark and drill one 9/32" hole using the template to locate the holes.
4. Mount the remote deflector mounting bracket (E, Figure 29) control to the dashboard using upper hole.
5. Align center of lower hole to dashed line on template and mark. Remove the remote deflector mounting bracket (E). Drill one 9/32" hole using the marked location.
6. Mount the remote deflector mounting bracket (E) control to the dashboard. Secure using two 1/4-20 x 7/8" capscrews (A) through the bracket (E) and dashboard.
7. Secure with 1/4 x 1-1/4 flatwashers (B), lockwashers (C), and nuts (D) on the BACKSIDE of the dashboard.

DO NOT OVER-TORQUE. Over-torquing may crack the dashboard.

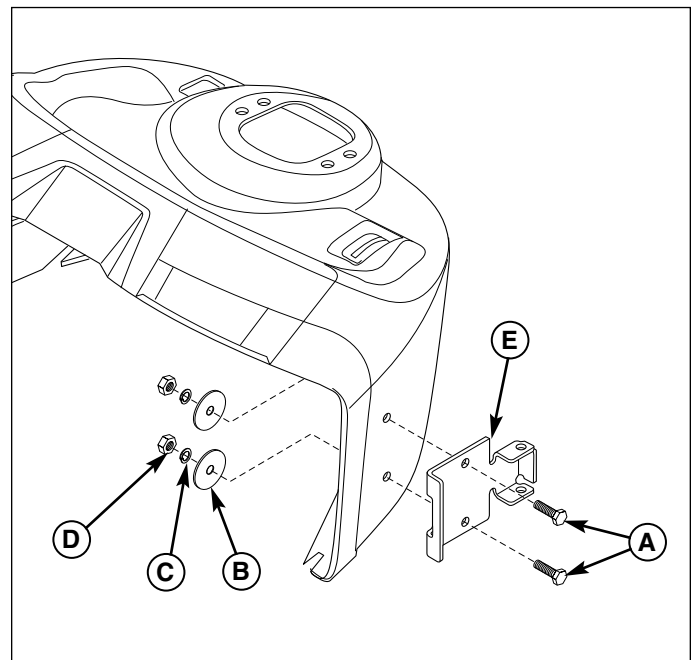
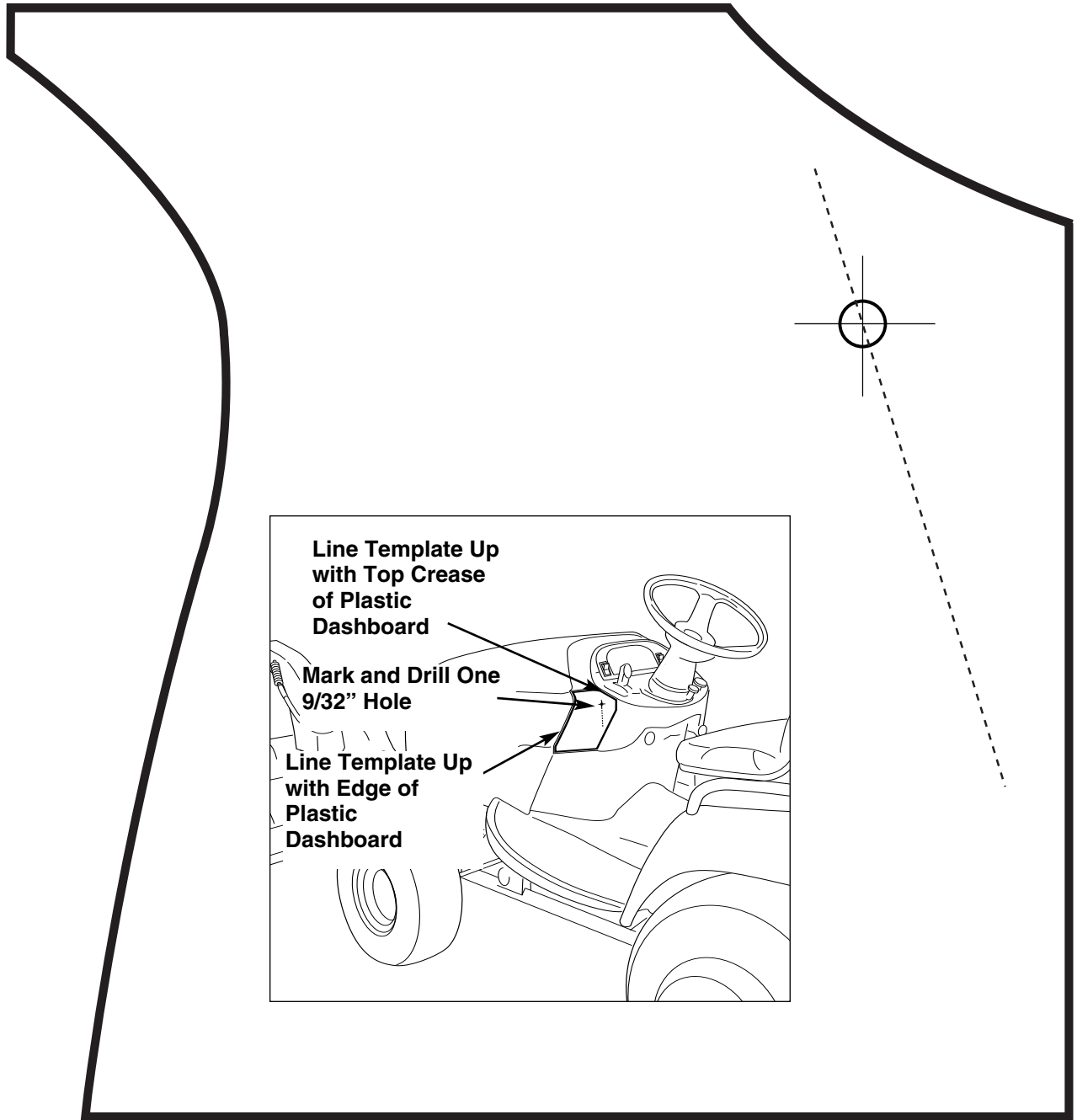

Figure 29. Mount Control Bracket - Current Models
A. 1/4-20 x 7/8 Capscrews
B. 1/4 x 1-1/4 Flatwashers
C. 1/4 Lockwashers
D. 1/4-20 Nuts
E. Mounting Bracket

Remote Deflector Control Template



Hardware Identification & Torque Specifications

Common Hardware Types

Hex Head Capscrew



Washer



Lockwasher



Carriage Bolt



Hex Nut



Standard Hardware Sizing

When a washer or nut is identified as **1/2"**, this is the *Nominal size*, meaning the *inside diameter* is 1/2 inch; if a second number is present it represents the *threads per inch*

When bolt or capscrew is identified as **1/2 - 16 x 2"**, this means the *Nominal size*, or *body diameter* is 1/2 inch; the second number represents the *threads per inch* (16 in this example, and the final number is the *body length* of the bolt or screw (in this example 2 inches long).

The guides and ruler furnished below are designed to help you select the appropriate hardware and tools.

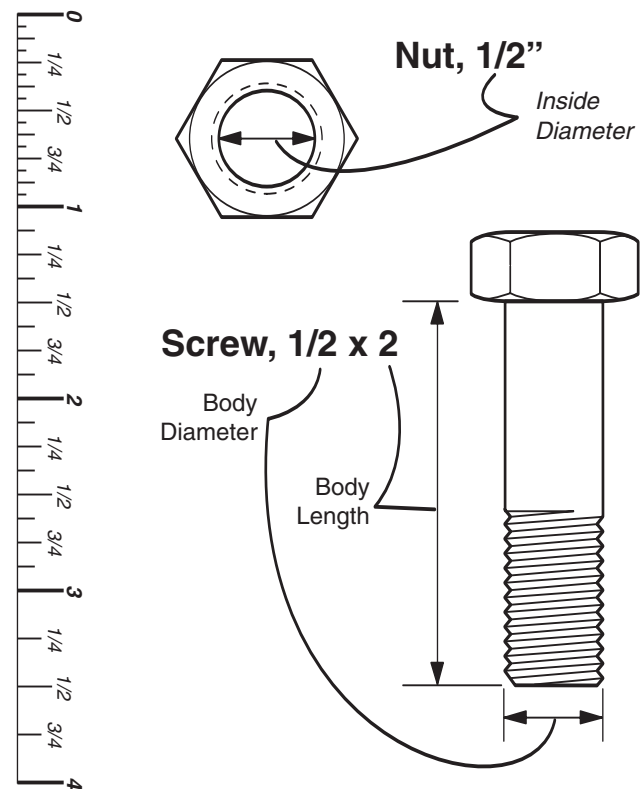

Torque Specification Chart						
FOR STANDARD MACHINE HARDWARE (Tolerance ± 20%)						
Hardware Grade	No. Marks SAE Grade 2		SAE Grade 5		SAE Grade 8	
	in/lbs ft/lbs	Nm.	in/lbs ft/lbs	Nm.	in/lbs ft/lbs	Nm.
8-32	19	2.1	30	3.4	41	4.6
8-36	20	2.3	31	3.5	43	4.9
10-24	27	3.1	43	4.9	60	6.8
10-32	31	3.5	49	5.5	68	7.7
1/4-20	66	7.6	8	10.9	12	16.3
1/4-28	76	8.6	10	13.6	14	19.0
5/16-18	11	15.0	17	23.1	25	34.0
5/16-24	12	16.3	19	25.8	27	34.0
3/8-16	20	27.2	30	40.8	45	61.2
3/8-24	23	31.3	35	47.6	50	68.0
7/16-14	30	40.8	50	68.0	70	95.2
7/16-20	35	47.6	55	74.8	80	108.8
1/2-13	50	68.0	75	102.0	110	149.6
1/2-20	55	74.8	90	122.4	120	163.2
9/16-12	65	88.4	110	149.6	150	204.0
9/16-18	75	102.0	120	163.2	170	231.2
5/8-11	90	122.4	150	204.0	220	299.2
5/8-18	100	136	180	244.8	240	326.4
3/4-10	160	217.6	260	353.6	386	525.0
3/4-16	180	244.8	300	408.0	420	571.2
7/8-9	140	190.4	400	544.0	600	816.0
7/8-14	155	210.8	440	598.4	660	897.6
1-8	220	299.2	580	788.8	900	1,244.0
1-12	240	326.4	640	870.4	1,000	1,360.0

NOTES

1. These torque values are to be used for all hardware excluding: locknuts, self-tapping screws, thread forming screws, sheet metal screws and socket head setscrews.
2. Recommended seating torque values for locknuts:
 - a. for prevailing torque locknuts - use 65% of grade 5 torques.
 - b. for flange whizlock nuts and screws - use 135% of grade 5 torques.
3. Unless otherwise noted on assembly drawings, all torque values must meet this specification.

Wrench & Fastener Size Guide



1/4" Bolt or Nut
Wrench—7/16"



5/16" Bolt or Nut
Wrench—1/2"

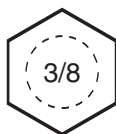

3/8" Bolt or Nut
Wrench—9/16"



7/16" Bolt or Nut
Wrench (Bolt)—5/8"
Wrench (Nut)—11/16"



1/2" Bolt or Nut
Wrench—3/4"