



**MODEL:  
Natural Gas Only  
0743512**



**MODEL:  
Propane Gas Only  
0743511**



## **Installation Instructions and Owner's Manual**

### ***Direct-Vent Wall Furnace***

**WARNING:** Improper installation, adjustment, alteration, service, or maintenance can cause injury or property damage. Refer to this manual. For assistance or additional information, consult a qualified installer, service agency or the gas supplier.

**WARNING:** Installation and repair must be done by a qualified service person. The furnace should be inspected before use and at least annually by a professional service person.

**WARNING:** If not installed, operated and maintained in accordance with the manufacturer's instructions, this product could expose you to substances in fuel or from fuel combustion which can cause death or serious illness and which are known to cause cancer, birth defects or other reproductive harm.

**WARNING:** If the information in this manual is not followed exactly; a fire or explosion may result, causing property damage, personal injury or loss of life.

- Do not store or use gasoline or other flammable vapors and liquids in the vicinity of this or any other appliance.
- **WHAT TO DO IF YOU SMELL GAS**
  - Open all windows.
  - Do not try to light any appliance.
  - Do not touch any electrical switch.
  - Do not use any phone in your building.
  - Extinguish any open flame.
  - Immediately call your gas supplier from a neighbor's phone. Follow the gas supplier's instructions.
  - If you cannot reach your gas supplier, call the fire department.
- Installation and service must be performed by a qualified installer, service agency or the gas supplier.

# Table of Contents

## General Information and Technical Data

Instructions to Installer .....	1
Safety Rules and General Warnings.....	2
Technical Data .....	3

## Installation

Wall Installation .....	4
Outside Location for Vent Terminal .....	5
Gas Supply.....	7

## Operating Instructions

Operating Instructions .....	9
------------------------------	---

## Servicing

Checking and Adjusting the Gas Manifold Pressure .....	10
Checking, Removing and Reassembling of the Vent Air Intake System .....	10
Lubrication of Moving Parts .....	10
Flame Visual Check .....	11

## General Information and Technical Data

*This furnace is design certified to ANSI Z21.86-2004 / CSA 2.32-2004 Gas-Fired Gravity and Fan-Type, Direct-Vent Wall Furnaces as a Fan-Type Direct-Vent Wall Furnace to be installed on an outside wall according to these instructions.*

*Any alteration of the original design, installed other than as shown in these instructions or used with a type of gas not shown on the rating plate is not permitted.*

## Instructions to Installer

Installation and repair should be done by a **QUALIFIED SERVICE TECHNICIAN**.

The installation must conform to local codes or in the absence of local codes; the installation must conform to the National Fuel Gas Code ANSI Z223.1/NFPA 54, Natural Gas and Propane Installation Code CSA B149.1.

Mobile (Manufactured) home installations must conform with the “Manufactured Home Construction and Safety Standard Title 24 CFR, Part 3280” or, when such a standard is not applicable, the Standard for Manufactured Home Installations, ANSI A 225.1 NFPA/501A, Mobile Home Standard, CAN/CSA Z240 MH Series, in Canada. Installer must leave instruction manual with home owner after installation. Installer must show home owner how to start and operate furnace and thermostat. Installer must provide a 1/8-inch NPT plugged tapping for test gauge connection immediately upstream of the gas supply connection of the furnace.

During initial firing of the furnace, residual manufacturing grease will bake out and smoke will occur which is not a health danger. To prevent nuisance and operation of fire alarms, ventilate the room for the first two hours of operation.

**WARNING: Any change to this furnace or its controls can be dangerous. This is a heating appliance and any panel, door or guard removed for servicing this furnace must be replaced prior to operating the furnace.**

## Safety Rules and General Warnings

*DO NOT OPERATE THIS FURNACE WITHOUT FRONT PANEL INSTALLED*

- Due to high temperatures, the furnace should be located out of traffic and away from furniture and draperies.
- Children and adults should be alerted to the hazards of high surface temperatures and should stay away to avoid burns or clothing ignition.
- Young children should be carefully supervised when they are in the same room as the furnace.
- Clothing or other flammable material should not be placed on or near the furnace.
- Any safety screen or guard removed for servicing a furnace must be replaced prior to operating the furnace.
- Keep burner and control compartment clean.
- The outside vent cap is hot while furnace is in operation.
- Installation and repair should be done by a QUALIFIED SERVICE TECHNICIAN. The furnace should be inspected before use and at least annually by a qualified service technician.
- More frequent cleaning may be required due to excessive lint from carpeting, bedding materials, etc. It is imperative that control compartments, burners and circulating air passageways of the furnace be kept clean.
- DO NOT put anything around the furnace that will obstruct the flow of combustion and ventilation air.
- DO keep the furnace area clear and free from combustible materials, gasoline and other flammable vapors and liquids.
- DO examine venting system periodically and replace damaged parts.
- DO examine burner periodically. Clean and replace damaged parts.
- DO NOT use this furnace if any part has been under water. Immediately call a qualified service technician to inspect the furnace and to replace any part of the control system and any gas control which has been under water.

## Safety Information for Users of LP Gas

Propane (LP Gas) is a flammable gas which can cause fires and explosions. In its natural state, propane is odourless and colourless. You may not know all the following safety precautions which can protect both you and your family from an accident. Read them carefully now, then review them point by point with the members of your household. Someday, when there may not be a minute to lose, everyone's safety will depend on knowing exactly what to do. If, after reading the following information, you feel you still need more information, please contact your gas supplier.

### LP Gas Warning Odour

**If a gas leak happens, you should be able to smell the gas because of the odorant put in the LP Gas.  
That's your signal to go into immediate action!**

- Do not operate electric switches, light matches or use your phone. Do not do anything that could ignite the gas.
- IMMEDIATELY get everyone out of the building, vehicle, trailer or area.
- Close all gas tank or cylinder supply valves.
- LP Gas is heavier than air and may settle in low areas such as basements. When you have reason to suspect a gas leak, keep out of basements and other low areas. Stay out until firefighters declare them to be safe.
- Use your neighbour's phone and call a trained LP Gas service technician and the fire department. Even though you may not continue to smell gas, do not turn on the gas again. Do not re-enter the building, vehicle, trailer or area.
- Have the service technician or fire department air out the area before you return. Properly trained LP Gas service technician must repair the leak, check and relight the gas furnace for you.

### Some Points to Remember

- **Learn to recognize the odour of LP Gas.** Your local LP Gas Dealer can give you a "Scratch and Sniff" pamphlet. Use it to find out what the propane odour smells like. If you suspect that your LP Gas has a weak or abnormal odour, call your LP Gas Dealer.
- If you are not qualified, do not light pilot lights, perform service, or make adjustments to furnaces on the LP Gas system. If you are qualified, consciously think about the odour of LP Gas prior to and while lighting pilot lights or performing service or making adjustments.
- Sometimes a basement or a closed-up house has a musty smell that can cover up the LP Gas odour. Do not try to light pilot lights, perform service or make adjustments in an area where the conditions are such that you may not detect the odour if there has been a leak of LP Gas.
- odour fade, due to oxidation by rust or absorption on walls of new cylinders and tanks, is possible. Therefore, people should be particularly alert and careful when new tanks or cylinders are placed in service. odour fade can occur in new tanks or reinstalled old tanks if they are filled and allowed to set too long before refilling. Cylinders and tanks which have been out of service for a time may develop internal rust which will cause odour fade. If such conditions are suspected to exist, a periodic sniff test of the gas is advisable. **If you have any question about the gas odour, call your LP Gas dealer. A periodic sniff test of the LP Gas is a good safety measure under any condition.**
- If, at any time, you do not smell the LP-Gas odorant, and you should, assume you have a leak. Then take the same immediate action recommended above for the occasion when you do smell the odorized LP Gas.
- If you experience a complete "gas out" (the container is under no vapour pressure), turn the tank valve off immediately. If the container valve is left on, the container may draw in some air through openings such as pilot light orifices. If this occurs, some new internal rusting could occur. If the valve is left open, then treat the container as a new tank. Always be sure your container is under vapour pressure by turning it off at the container before it goes completely empty or having it refilled before it is completely empty.

### Technical Data

OUTPUT HEATING CAPACITY	kW	1.61
	BTU/hr.	5,500
INPUT RATING	kW	2.17
	BTU/hr.	7,400
MINIMUM INPUT RATING	kW	1.58
	BTU/hr.	5,400
THERMAL EFFICIENCY	%	74.32
LENGTH	mm	478
	in	18-7/8"
HEIGHT	mm	577
	in	22-3/4"
DEPTH	mm	173
	in	6-3/4"
WEIGHT (OPERATING/SHIPPED)	kg	17/20
	lbs.	37/44
GAS CONNECTION	NPT	1/2" MALE
WALL HOLE DIAMETER	mm	105
	in	4-1/8"
AIR INLET DIAMETER	mm	100
	in	3-7/8"
EXHAUST PIPE DIAMETER	mm	60
	in	2-3/8"
MAX WALL THICKNESS	mm	495
	in	19-1/2"
MIN WALL THICKNESS	mm	150
	in	6

MANIFOLD PRESSURE	MAX	NATURAL GAS	mbar	8.7
			in w.c.	3.5
	MIN	LP	mbar	24.9
			in w.c.	10.0
GAS RATE	MAX	NATURAL GAS	m <sup>3</sup> /h	0.20
			ft <sup>3</sup> /h	7.0
	MIN	LP	m <sup>3</sup> /h	0.08
			ft <sup>3</sup> /h	3.0
MINIMUM INLET PRESSURE	MAX	NATURAL GAS	m <sup>3</sup> /h	0.14
			ft <sup>3</sup> /h	5.1
	MIN	LP	m <sup>3</sup> /h	0.06
			ft <sup>3</sup> /h	2.2

## Installation

*Installation should be done by a QUALIFIED SERVICE TECHNICIAN.*

*The furnace must be located on an outside wall.*

### Wall Installation

Minimum clearances from combustible materials:

- Unit to the top surface of carpeting, tile:  
2-inches (50 mm)
- Unit to back wall (0" to spacers):  
1/4-inch (6.3 mm).
- Vent to wall enclosure:  
1-inch (25.4 mm)
- Unit to sidewalls:  
2-inches (50 mm)
- Unit to ceiling:  
10-inches (254 mm)

See Figure 1 showing clearance for installation of vent cap.

Leave at least three feet in front of the wall furnace for servicing and proper operation. The wall furnace must be installed in such a way that the external casing can be completely removed for servicing.

If there is a shelf above the furnace, it must be non-combustible. A minimum clearance of 4-inches (100 mm) is recommended between the furnace and the non-combustible shelf above it.

Gas equipment in residential garages must be installed so that all burners and burner ignition devices are located not less than 18-inches (460 mm) above the floor. Such equipment shall be located, or protected, so it is not subject to physical damage by a moving vehicle.

The vent terminal of this direct-vent furnace must be located at least 9-inches (230 mm) from any opening through which flue gases could enter a building. The bottom of the vent terminal and the air intake must be located at least 12-inches (300mm) above grade.

DO NOT cover the furnace.

Make sure that the correct gas supply is available. Conversion To another gas type must be performed by a qualified service technician. If the type of gas does not correspond to the type to be used (natural or LP Gas), it must be converted to the correct type of gas. It is necessary to do the following two operations:

1. Remove and change the pilot orifice with the correct gas type as shown below.
2. Remove and change the burner orifice with the correct gas type as shown below.
3. Remove and change the gas valve with the correct gas type as shown below.

Gas Type	Orifice Part Numbers	Gas Valve
Natural	Burner Orifice: JGLL051; Pilot Orifice: JGLL064	JVLV023
Propane (LP Gas)	Burner Orifice: JGLL070; Pilot Orifice: J12160880	JVLV024

**WARNING: For the installation of this furnace, the following items must be used as a vent air intake system:**

**External Plate**

(Part Number: WFL-STF003)

**External Vent Cap**

(Part Number: WFR-12426530)

**Flanged Air Inlet Tube**

(Part Number: WFR-12476500)

**Air Tube Gasket**

(Part Number: WFC-12900128)

**Flue Outlet Tube**

(Part Number: WFR-12476510)

**(All the above items are supplied with the furnace)**  
The diameter of the hole in the wall must exceed at least 2-inches (50 mm) the diameter of the air inlet tube.

**WARNING: The nearest point of the vent cap should be a minimum horizontal distant of six (6) feet (1,830 mm) from any pressure regulator. In case of regulator malfunction, the six (6) feet (1,830 mm) distance will reduce the chance of gas entering the vent cap.**

Figure 1

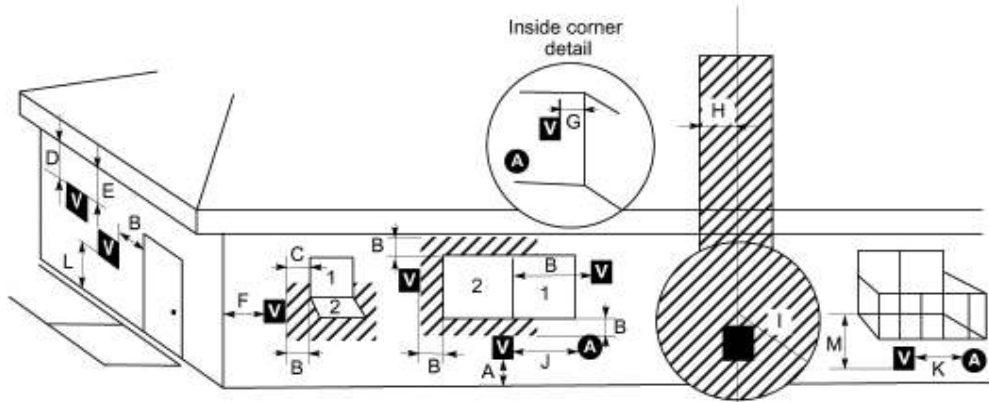

1 = Fixed/Closed

2 = Openable

V = Vent Terminal

A = Air Supply

- A. Clearance above grade, veranda, porch, deck or balcony 12-inches (30 cm) minimum. <sup>(3)</sup>
- B. Clearance to window or door that may be opened 12-inches (30 cm) minimum. <sup>(3)</sup>
- C. Clearance to permanently closed window (minimum 12-inches (30 cm) recommended to prevent condensation on window.
- D. Vertical clearance to ventilated soffit located above the terminal within a horizontal distance of 2 feet (60 cm) from the centerline of the terminal 18-inches (46 cm) minimum.
- E. Clearance to unventilated soffit 12-inches (30 cm) minimum clearance to vinyl soffit 36-inches (90 cm) minimum.
- F. Clearance to outside corner 12-inches (30 cm) minimum.
- G. Clearance to inside corner 18-inches (46 cm) minimum.
- H. Not to be installed above a meter/regulator assembly within 3 feet (90 cm) horizontally from the centreline of the regulator. <sup>(3)</sup>
- I. Clearance to service regulator vent outlet 6 feet (1.8 m) minimum. <sup>(3)</sup>
- J. Clearance to nonmechanical air supply inlet to building or the combustion air inlet to any other furnace 12-inches (30 cm) minimum. <sup>(3)</sup>
- K. Clearance to a mechanical air supply inlet 6 feet (1.8 m) minimum. <sup>(3)</sup>
- L. Clearance <sup>(1)</sup> above paved sidewalk or a paved driveway located on public property 7 feet (2.1 m) minimum. <sup>(3)</sup>
- M. Clearance under veranda, porch, deck or balcony 12-inches (30 cm) minimum. <sup>(2), (3)</sup>

Notes:

- (1) A vent shall not terminate directly above a sidewalk or paved driveway which is located between two single family dwellings and serves both dwellings.
- (2) Only permitted if veranda, porch, deck or balcony is fully open on a minimum of two sides beneath the floor.
- (3) As specified in CGA B149 installation codes (1991).

Note: Local codes or regulations may require different clearances.

## Outside Location for Vent Terminal

Upon delivery, check to make sure the packaging has not been damaged.

1. Remove the furnace from box/packaging taking care not to damage the paper template. This is to be used to mark the holes for mounting the furnace.
2. After marking where the appropriate holes will be using the above mentioned template, make a 6-inch (152.4 mm) diameter hole.
3. Cut the combustion exhaust and fresh air inlet tubes according to the wall thickness:  
**Air inlet tube length = wall thickness + 11/16 in. (14.4 mm)**  
**Flue outlet tube length = wall thickness + 3 in. 9/16 (90.5 mm)**
4. Drill the mounting holes "A" (5 holes) in the wall. If the wall can receive self-tapping screws, drill 1/8-inch diameter holes. If not, drill 1/4-inch diameter holes and use the plastic anchors provided.

5. Place the insulating sheet on the support bracket and attach the bracket with insulation to the wall by tightening the five screws with washer. (Figure 3) Be sure the bracket is horizontal.
6. Remove the casing from the furnace body, unscrewing the two mounting screws. (Figure 3).
7. Mount the largest tube (diameter 4-inches (101.6 mm) and the gasket on the unit frame with the screws provided. Insert the smallest tube (diameter 2½-inches, 63.5 mm) in the combustion chamber. (Figure 4).

Figure 2

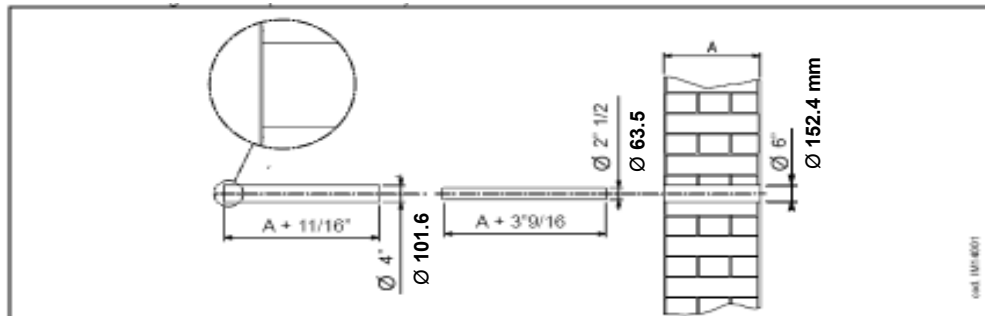

Figure 3

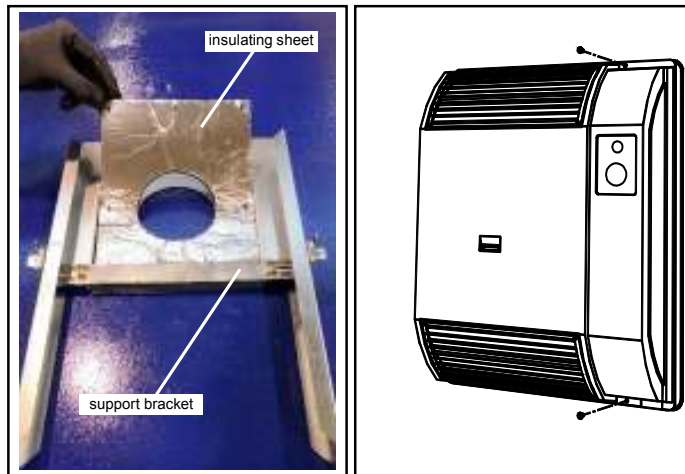
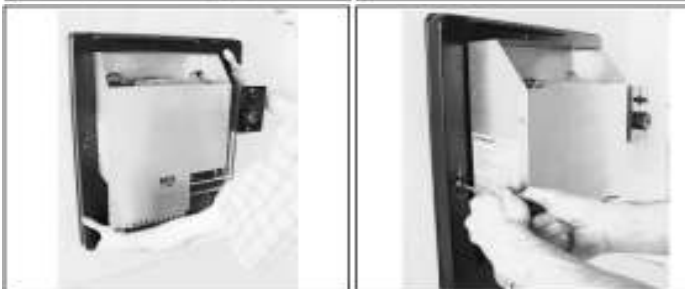

Figure 4



Figure 5



8. Position the furnace on the wall inserting the inlet/outlet flue in the hole previously drilled. Make sure that the edges of the support bracket perfectly match the existing holes in the back on the unit (Figure 5).
9. Attach the furnace to the support bracket with the two screws provided. During this operation make all necessary adjustments to have a correct installation of the unit (Figures 5 and 6).
10. Reinstall the external casing by tightening the relevant screws (Figure 3).
11. On the external side of the wall, install the protection plate in such a way that the centre of the hole in the plate matches the centre of the hole in the wall. First place the plate in the right position and mark the holes on the wall. Then, remove the plate and drill the holes in the wall. If the wall can receive self-tapping screws, drill 1/8-inch diameter holes. If not, drill 1/4-inch diameter holes and use the plastic anchors provided. Reposition the plate and fix it onto the wall with the four screws provided. (Figure 7 - Left).
12. Mount the vent cap on the flue pipe and fix it onto the external plate with the three self-tapping screws provided. (Figure 7 - Right).
13. Connect the gas supply line. A gas tap just before each furnace must be installed.
14. Turn on gas supply and check for gas leaks with soapy water or other suitable means on all gas connections.

Figure 6



Figure 7



## Gas Supply

Check all local codes for requirements, especially for the size and type of gas supply line required. On natural gas lines less than 15" (380 mm) long, use 1/2" tube; on longer runs, use 3/4" iron tube or equal. On LP gas lines please consult LP Gas supplier.

### Installing a New Main Gas Cock

Each furnace should have its own manual gas cock. A manual main gas cock should be located in the vicinity of the unit. Where none exists, or where its size or location is not adequate, contact your local authorized installer for installation or relocation.

Compounds used on threaded joints of gas piping shall be resistant to the action of LP Gas. The gas lines must be checked for leaks by the installer. This should be done with a soap solution watching for bubbles on all exposed connections, and if unexposed, a pressure test should be made.

**Never use an exposed flame to check for leaks. Furnace must be disconnected from piping at inlet of control valve and pipe capped or plugged for pressure test. Never pressure test with furnace connected; control valve will sustain damage!**

A gas valve and ground joint union should be installed in the gas line upstream of the gas control to aid in servicing. It is required by the National Fuel Gas Code that a drip line be installed near the gas inlet. This should consist of a vertical length of pipe tee connected into the gas line that is capped on the bottom in which condensation and foreign particles may collect. The use of the following gas connectors is recommended:

- ANSI Z21.24 Appliance Connectors of Corrugated Metal Tubing and Fittings., CGA 6.10.
- ANSI Z21.45 Assembled Flexible Appliance Connectors of Other Than All-Metal Construction.

The above connectors may be used if accepted by the authorities having jurisdiction.

### Pressure Testing of the Gas Supply System

1. To check the inlet pressure to the gas valve, a plugged tapping, accessible for test gauge connection, is provided on the gas valve. (Figure 8 - A).
2. The furnace and its individual shutoff valve must be disconnected from the gas supply piping system during any pressure testing of that system at test pressures in excess of 1/2 psig (3.5 kPa).



3. The furnace must be isolated from the gas supply piping system by closing its individual manual shutoff valve during any pressure testing of the gas supply piping system at test pressures equal to or less than 1/2 psig (3.5 kPa).

**Attention:** If one of the above procedures results in pressures in excess of 1/2 psig (14" w.c.; 3.5 kPa) on the furnace gas valve, it will result in a hazardous condition.

### High Altitudes (US Only)

For altitudes/elevations above 2,000 feet (610 m), ratings should be reduced at the rate of 4-percent for each 1,000 feet (305 m) above sea level by reducing the manifold pressure at 8% rate on the gas supply. Maximum altitude allowed for installation is 5500 feet (1680 m).

### High Altitudes (Canada Only)

The furnace is tested according to CGA 2.17 M91 for installation between 0 and 4500 ft (0 and 1370 m) altitude. For altitudes/elevations above 2,000 feet (610 m), ratings should be reduced at the rate of 4-percent for each 1000 feet (305 m) above sea level by reducing the manifold pressure at 8% rate on the gas supply. Maximum altitude allowed for installation is 5500 feet (1680 m).

### First Firing the Furnace

Start the furnace following the instructions given in the "Operating Instructions". The first lighting can be difficult because of the air trapped in the gas lines. During initial firing of the furnace, residual manufacturing grease will bake out and smoke will occur which is not a health danger. To prevent nuisance and operation of fire alarms, ventilate the room for the first two hours of operation.

### Checking the Gas Inlet Pressure

The gas inlet pressure can be measured by connecting a test gauge to the connection provided on the gas valve. (Figure 8 - A) Once installation is complete, the gas inlet pressure must be checked. The minimum gas inlet pressure must be as shown in "Technical Data". After checking the gas inlet pressure, disconnect the test gauge and firmly tighten the screw of the gauge connection, then check for gas leaks.

### Checking the Gas Manifold Pressure

The gas manifold pressure can be measured by connecting a test gauge to the connection provided on the gas valve. (Figure 8 - B). The furnace comes set from the factory at the correct manifold gas pressure. After the installation is completed, the gas manifold pressure must be checked both in Hi and Lo input. Turn the control knob to switch the unit from Hi to Lo input. The position of the knob in which this occurs depends on the actual room temperature. The gas manifold pressure must be as shown in "Technical Data". Differences of plus or minus 0.1 in. w.c. are accepted. If the Hi or Lo gas manifold pressures are different from the values given in the "Technical Data" or are more than 0.1 in. w.c., shut off the furnace and contact a qualified service technician.

For instructions about adjustment of the manifold Hi and Lo pressures, see the "Servicing" section. After checking the gas manifold pressure, disconnect the test gauge and tighten firmly the screw of the gauge connection, then check for gas leaks from it.

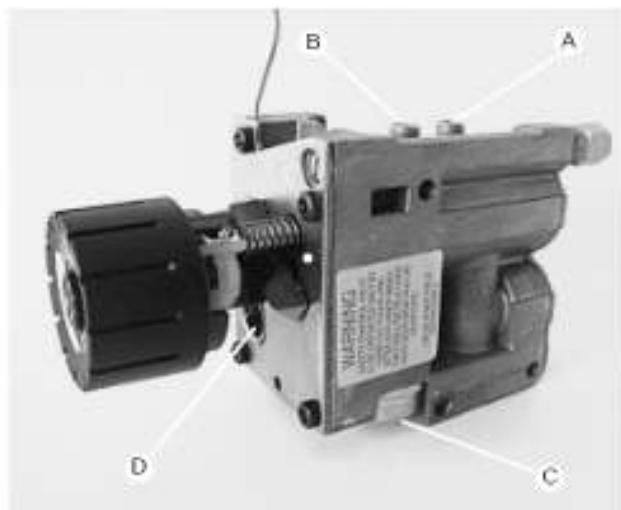

Figure 8

- A: test gauge connection for gas inlet pressure
- B: test gauge connection for gas manifold pressure
- C: screw for Hi pressure adjustment (pressure regulator)
- D: screw for Lo pressure adjustment (Hi - Lo operator)

## Operating Instructions



Before operating the furnace, read carefully all warnings and safety information in this manual.

### FOR YOUR SAFETY READ BEFORE OPERATING

**WARNING:** If you do not follow these instructions exactly, a fire or explosion may result causing property damage, personal injury or loss of life.

- A. This appliance has a pilot which must be lighted by means of the piezo igniter installed on the unit. Do not try to light the pilot by hand.
- B. BEFORE LIGHTING smell all around the appliance area for gas. Be sure to smell next to the floor because some gas is heavier than air and will settle on the floor.
- WHAT TO DO IF YOU SMELL GAS:**
- Do not try to light any appliance
  - Do not touch any electric switch; Do not use any phone in your building
  - Immediately call your gas supplier from a neighbour's phone.
- Follow the gas supplier's instructions.  
- If you cannot reach your gas supplier, call the fire department.
- C. Use only your hand to push in or turn the gas control knob. Never use tools. If the knob will not push in or turn by hand, don't try to repair it, call a qualified service technician. Force or attempted repair may result in a fire or explosion.
- D. Do not use this appliance if any part has been under water. Immediately call a qualified service technician to inspect the appliance and to replace any part of the control system and any gas control which has been under water.

### OPERATING INSTRUCTIONS

1. STOP! Read the safety information above on this label.
2. Turn gas control knob clockwise  to OFF. Do not force.
3. Wait (5) minutes to clear out any gas. If you then smell gas, STOP! Follow "B" in the safety information above on this label. If you don't smell gas, go to the next step.
4. Turn gas knob counterclockwise  to PILOT.
5. Look inside the flame view which is located on the external casing.
6. Push in control knob all the way and hold in. Immediately press the piezo igniter to end of the stroke, then release it. Continue pressing and releasing the piezo igniter with the control knob pressed down, until the pilot flame appears in the flame view. Once the pilot flame is lit, hold the control knob in for about one (1) minute.
7. Release knob and it will pop back up. Pilot should remain lit. If it goes out, repeat steps 2. through 6. .
  - If knob does not pop up when released, stop and turn the gas tap installed on the gas supply line to the CLOSED position. Immediately call your service agency or gas supplier.
  - If the pilot will not stay lit after several tries, turn the gas control knob to OFF and call your service technician or gas supplier.
8. Turn the control knob counterclockwise  to the desired setting between HI and LO. The main burner flame will appear.



### TO TURN OFF GAS TO APPLIANCE

1. Turn the control knob clockwise  to OFF position. Do not try to switch from HI to OFF directly. Do not force.
2. Turn the gas tap installed on the gas supply to the CLOSED position.

## Servicing

*All servicing activities must be carried out by a qualified service technician or a service agency. The home owner may not service the furnace. The home owner must read this section to be informed of the periodic maintenance and checks the required. All servicing (except on vent system) must be carried out with the external casing removed. After any servicing, the external casing must be reinstalled properly.*

### Checking and Adjusting the Gas Manifold Pressure

The furnace comes set from the factory at the correct HI and LO gas manifold pressures as shown in "Technical Data". It is recommended to check the pressures periodically (minimum once a year). If adjustment is required, this can be done by adjusting screws C and D. (Figure 8) A test gauge must be connected as explained in "Checking the Gas Manifold Pressure".

Proceed as follows:

1. Place the unit on and in the HI mode (knob in HI position).
2. Adjust the HI pressure by turning the screw C (pressure regulator) to the value given in "Technical Data". Turn clockwise to increase the pressure, turn counterclockwise to decrease it.
3. Turn the control knob clockwise until the gas control switches to LO mode. The position in which this occurs depends on the actual room temperature.
4. Loosen screw D until the correct value for the LO pressure is achieved. Turn clockwise to decrease the pressure, turn counterclockwise to increase it.
5. Switch the unit from LO to HI mode to check that both the HI and LO pressures are correct. A tolerance of plus or minus 0.1-inches w.c. on the pressure value is acceptable. Readjust if needed.
6. Disconnect the test gauge and tighten firmly the screw of the gauge connection, then check for gas leaks from it.

The HI and LO pressures must be adjusted in the way explained above. Never try to adjust them independently from each other.

### Checking, Removing and Reassembling of the Vent Air Intake System

It is essential that the vent air intake system is examined periodically (minimum once a year) to verify it is clean from dust and deposits of solid materials such as leaves or nests. The vent air intake system is checked from outside. Proceed as follows:

1. Remove the vent cap by removing the three outer screws. (Figure 7)
2. Remove the inner flue pipe. **Do not use tools**; the pipe can be extracted by hand.
3. Remove dust and deposits from the vent cap and flue pipes. Deposits in the air pipe must be taken outside. **Do not push them inside the furnace**. The outer air pipe may not be removed from outside.
4. Reinstall the flue pipe from outside. Do not use glue or sealants.
5. Reinstall the vent cap on the flue pipe. Do not use glue or sealants. Tighten the three outer screws.







### Lubrication of Moving Parts

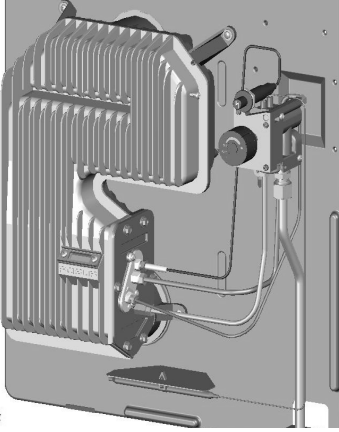

This furnace does not require lubrication. Do not try to lubricate any part of the furnace such as motors bearings, keys, knobs, screws, etc.

### Flame Visual Check

Correct and proper operation of the burner may be checked by examining the burner flame. The flame may be examined through the front flame viewer. The flame must be stable and have blue colour. Some small yellow tips are acceptable with propane gas. If the flame is yellow or has excessive turbulence, check the gas manifold pressure and the vent air intake system. If all these are acceptable, call a qualified service technician for a complete check of the furnace. Call also your gas supplier to check the composition of the gas in use.

## Replacement Parts

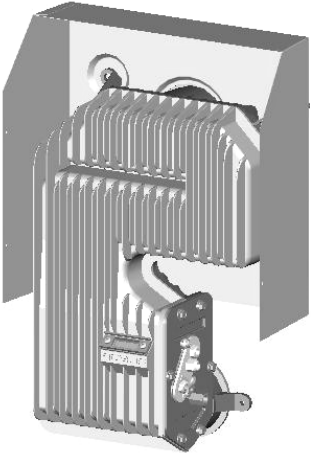
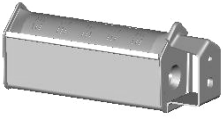
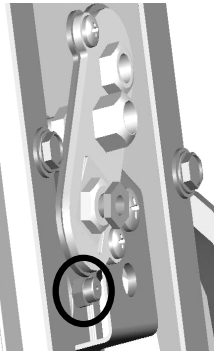
		Gas valve		Part Number: P332525 (Nat gas)  Part Number: P332526 (LPG)
			Pilot Sparking Candle and Nozzle	Part Number: P332497 (Sparking candle)  Part Number: P332506 (Nat gas)  Part Number: P332495 (LPG)
				Piezo Electric Button
		Thermocouple		Part Number: P332557

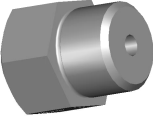
		Burner		Part Number: P332546
			Pilot	Part Number: P332542
			Pilot Gasket	Part Number: P332498
			Burner Nozzle	Part Number: P332505 (Nat gas)  Part Number: P332507 (LPG)