

# Electric Mini-Boiler™

## Installation & Operating Instructions

**Application:** This Electro Mini-Boiler is factory equipped with **WarmFlo®** smart controller with integrated two zone control. **WarmFlo** automatically regulates outlet water temperature based upon preset, front panel, and temperature selection. This model is equipped with up to two zone control inputs and corresponding pump/valve outputs, backup gas boiler output, auto and manual high limit safety interlocks, power company load management, and up to three temperature sensors depending on the model.

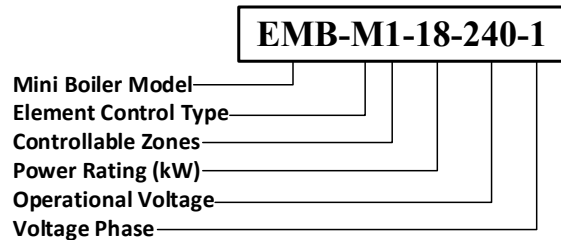

Primary application is any hydronic water heating system (high or low temperature systems). When properly sized, implementing a mixture of large and small zones in the two zone control models enables precise control adapting to capacity and flow changes.

This series is equipped for power company load management interrupt and can apply to standard baseboard radiation, dual heat combinations, under floor radiant, wood boiler supplement, etc.

**Accessories:** Attached BL001 lists various accessory or option items which are not part of basic Electro-Boiler.

**Note:** This product meets the requirements of the ASME Boiler and Pressure Vessel Code.

Conforms to: UL STD.UL834

Certified to: CSA STD.C22.2#165

DO NOT DESTROY THIS MANUAL. PLEASE READ CAREFULLY AND KEEP IN A SAFE PLACE FOR FUTURE REFERENCE BY A SERVICE TECHNICIAN.



**ELECTRO**  
**INDUSTRIES**  
Monticello, MN - 800.922.4138 - www.electromn.com

# TABLE OF CONTENTS

<u>Description</u>	<u>Page</u>
System Components	1
Mini-Boiler Selection Guide	1
Electrical Specifications	2
Water Flow Requirements	3
Multiple Zones & Radiant Temperatures	4
Modulating Control	4
Safety Temperature Control	4
Room Thermostat Placement	5
Water Flow Calculation	5
Installation Requirements	5
Electric Supply	6
Clearances	7
Mechanical Installation	8
Electrical Hookup	9
Water Additives	11
Water Fill Procedure	12
WarmFlo Hi Temperature Mode & Emergency Heat	13
Zone 2 Temperature Selection	13
Operational Tips	14
Troubleshooting Helps	15
Drawings:	BX306 BH311 UAW431 BL001 XX017

## INTRODUCTION

The Mini-Boiler has been designed in a compact package with up to 18 kW of heating capabilities for radiant heat applications. When properly sized, the Mini-Boiler will provide the needed hot water to properly heat a space in a single zone or multi-zone application. The EMB-M Series models provide industry leading hydronic control for precise temperature management and ease of use. With its unique WarmFlo technology and integrated zone controller, the Mini-Boiler can easily modulate output based on the level of demand from a single or multi-zone system. Proper design of the radiant system is required to assure minimum required water flow (GPM) through the boiler.

## GENERAL

The basic **components** for an electric energy heating system typically include:

1. Electric Mini-Boiler itself – covered by this manual.
2. Thermostat hookup control – covered by this manual.
3. Outdoor Thermistor – if outdoor reset option is ordered as a kit, reference catalog number 6206KIT.
4. Plumbing kit or piping material at the boiler itself – can be ordered as a kit, reference catalog number EMB-PK.
  - a. These items are shown on plumbing installation drawing BX306.
5. Circulating pump – typically sized for head pressure and system flow requirement, typical catalog number EMB-P2.
6. Radiant heat devices/components.

## MINI-BOILER SELECTION GUIDE

Mini-Boiler Selection Guide 1-9 kW								
Element Control	Phase	Zones	Voltage	Power Rating (kW)				
				1	3	5	7	9
Modulating	1	2	120VAC	EMB-M2-01-120-1	EMB-M2-03-120-1	-	-	-
			240VAC	-	-	EMB-M2-05-240-1	EMB-M2-07-240-1	EMB-M2-09-240-1

Mini-Boiler Selection Guide 10-18 kW						
Element Control	Phase	Zones	Voltage	Power Rating (kW)		
				3	6	9
Modulating	1	2	240VAC	EMB-M2-12-240-1	EMB-M2-15-240-1	EMB-M2-18-240-1

## ELECTRICAL SPECIFICATIONS

<b>Model</b>	<b>Power Input, Operation</b>	<b>Circuit Breakers</b>	<b>Power Rating</b>	<b>Amps</b>	<b>Btu/h</b>
EMB-M2-01-120-1	120-volt, 1-Modulating	–	1.4 kW	11.7A	4,777
EMB-M2-03-120-1	120-volt, 1-Modulating	–	3.0 kW	25.0A	10,236
EMB-M2-05-240-1	240/208-volt, 1-Modulating	30A CB	5.0/3.8 kW	20.8A / 18.0A	17,060/12,796
EMB-M2-07-240-1	240/208-volt, 1-Modulating	45A CB	7.0/5.3 kW	29.2A / 25.2A	23,885/17,913
EMB-M2-09-240-1	240/208-volt, 1-Modulating	60A CB	9.0/6.8 kW	37.5A / 32.5A	30,709/23,032
EMB-M2-12-240-1	240/208-volt, 2-Modulating	45A+45A CB	12.0/9.0 kW	50.0A / 43.3A	40,945/30,709
EMB-M2-15-240-1	240/208-volt, 2-Modulating	45A+45A CB	15.0/11.3 kW	62.5A / 54.1A	51,182/38,386
EMB-M2-18-240-1	240/208-volt, 2-Modulating	60A+60A CB	18.0/13.5 kW	75.0A / 64.9A	61,418/46,063

## APPROVED TUBING/PIPING

When plumbing this boiler and its peripheral parts to the radiant floor loop system, all plumbing parts and/or tubing must be sealed to prevent entrance of oxygen.

**Use only tubing or polyethylene tubing with oxygen Diffusion Barrier (ie. PEX).**

## WATER FLOW REQUIREMENTS

In order to prevent rapid stage cycling and long term deterioration of components and elements, it is important the water flow be greater than the specified 0.3 GPM per kW.

(MINIMUM 0.3 GPM PER KW WATER FLOW THROUGH BOILER)

Model	Water Temperature Rise							
	Flow – 10° F/6° C		Head Loss		Flow – 20° F/11° C		Head Loss	
	gpm	lpm	ft	m	gpm	lpm	ft	m
EMB-M2-01-120-1	0.96	3.62	0.012	0.004	0.48	1.81	0.003	0.001
EMB-M2-03-120-1	2.05	7.75	0.051	0.016	1.02	3.87	0.014	0.004
EMB-M2-05-240-1	3.41	12.92	0.132	0.040	1.71	6.46	0.037	0.011
EMB-M2-07-240-1	4.78	18.08	0.246	0.075	2.39	9.04	0.068	0.021
EMB-M2-09-240-1	6.14	23.25	0.392	0.119	3.07	11.62	0.109	0.033
EMB-M2-12-240-1	8.19	31.00	0.667	0.203	4.09	15.50	0.185	0.056
EMB-M2-15-240-1	10.24	38.75	1.009	0.308	5.12	19.37	0.279	0.085
EMB-M2-18-240-1	12.28	46.50	1.414	0.431	6.14	23.25	0.392	0.119

Note: Head Loss based on 110° F return temperature, approximately 3 feet of Mini-Boiler ¾” pipe, and a Hazen-Williams Coefficient of 140.

## MULTIPLE ZONES AND RADIANT TEMPERATURES

**Same water temperature all zones** – in this case the system can be setup as one or two pumps through relay pump contacts inside the boiler chassis. Water is circulated through the boiler directly to a manifold containing the various zone valves. This model series has a built-in supply control algorithm for modulating the elements for up to two zones directly. If more than two zones are required, a zone controller may be used. If using zone valves, the end switches of all the zone valves are paralleled and directly control the respective R and W zone inputs to turn on the boiler according to the temperature selected on the front of the boiler. Since zone valves have a slow reaction time, to ensure proper temperature regulation output from the boiler when using zone valves, always connect the end switches of the zone valves to the respective R and W zone inputs.

**Two zones with different water temperatures** - in this case the system can be setup as two pumps through relay pump contacts inside the boiler chassis. Water is circulated through the boiler and directly to a manifold containing the various zone valves. Temperatures for Zone 1 is selected on the front of the outside of the boiler and Zone 2 is selected and enabled through the DIP switch inside the top front door of the boiler. If using zone valves, the end switches of all the zone valves are paralleled and directly control the respective R and W zone inputs to turn on the boiler according to the temperature selected based on the zone. Zone 1 always has priority in temperature over Zone 2. Since zone valves have a slow reaction time, to ensure proper temperature regulation output from the boiler when using zone valves, always connect the end switches of the zone valves to the respective R and W zone inputs.

### CAUTION

ELECTROCUTION IS A RISK INSIDE THE ENCLOSURE OF THE BOILER. ALWAYS TURN POWER OFF TO THE BOILER PRIOR TO MODIFYING THE ZONE 2 TEMPERATURE SETPOINT OR ACTIVATION LOCATED INSIDE THE BOILER. HAZARDS OR UNSAFE PRACTICES COULD RESULT IN PROPERTY DAMAGE, PRODUCT DAMAGE, SEVERE PERSONAL INJURY AND/OR DEATH.

**Various water temperature requirements** – if this is the case, a primary loop with mixing valve for the various zone temperature requirements is necessary. Injection pump techniques can also be used. However, usually injection pump techniques come with a controller which is designed to protect a gas boiler from cool water return. This is simply not needed and a duplication with the temp sensing controller within this Mini-Boiler and the injection pump controller will be of no benefit within the operating system. The zone valve/zone pump control strategy must be wired to provide the boiler “R and W” contact closure and the primary pump is connected to the boiler pump contacts. This assures the primary pump is active and running whenever the boiler is turned on via contact closure on “R and W”. At least one zone must be open before turning on the primary pump/Mini-Boiler. Do not design a system where the Mini-Boiler is supposed to operate as a “hot boiler” based upon its outlet sensor without the primary pump circulating water, minimum .3 GPM is required.

## MODULATING CONTROL

This Mini-Boiler series is factory equipped to precisely control output water temperature through an integrated zone controller with PID control algorithm utilizing zones calls, priorities and set points, supply and outdoor temperatures. The controller automatically regulates the elements to maintain a preset operating temperature. The control board has a front panel screwdriver adjustment (see Operational Tips section) for setting the operating temperature point for Zone 1 and DIP switch adjustment for setting the operating temperature of Zone 2. The EMB-M Series provides industry leading temperature regulation and operation through complete element modulation in 1 or 2 elements based on model.

## SAFETY TEMPERATURE CONTROL

The hi-limits within this unit are for safety purposes only. The system installation must have a proper responding slab or air sensing thermostat or zone controlling device to properly turn the boiler on and off. If the water flow is greater than the nominal GPM specified and the heat load large enough, this boiler should not reach hi-limit and the hydronic loop should continue to flow in the normal heating pattern until the operating slab stat is satisfied. If hi-limiting is experienced prior to satisfying the operating stat, there is likely a water flow issue.

In addition to the built-in supply temperature sensor and temperature control algorithm, there is a 190° F automatic reset hi-limit and a 205° F top vessel manual reset hi-limit.

## ROOM THERMOSTAT PLACEMENT – RADIANT FLOOR

Comfort and proper space heating response is a direct relationship to the room thermostat type. For optimal system performance, Electro recommends using a slab sensing thermostat. This type of thermostat uses a remote sensor placed within the concrete slab via a piece of conduit or pex tube installed prior to pouring the slab.

If provisions were not made for a floor sensing thermostat, most any brand of air thermostat will work. We suggest setting the cycles per hour adjustment to a value of 1-2.

## INFORMATION/WATER FLOW CALCULATIONS

Water flow, GPM, can easily be calculated if the temperature rise across the electric boiler can be measured. The following formula can only be used when the temperature rise is stable and the boiler is not hi-limiting. In other words, verify constant current draw and stable outlet temperatures for at least 15 minutes.

$$\text{GPM} = \frac{\text{Volts} \times \text{Amps} \times 3.4}{500 \times \text{Temp. rise}} \quad \text{Example: } \frac{240 \text{ volts} \times 36 \text{ amps} \times 3.4}{500 \times 10 \text{ degree rise}} = \frac{29376}{5000} = 5.8 \text{ gpm}$$

## INFORMATION/WATER FLOW CALCULATIONS – METRIC

$$\text{L/min} = \frac{\text{Volts} \times \text{Amps} \times 3.587}{251.04 \times \text{Temp. rise } ^\circ \text{C}} \quad \text{Example: } \frac{240 \text{ volts} \times 36 \text{ amps} \times 3.587}{251.04 \times 6^\circ \text{C rise}} = \frac{30991.68}{1506.24} = 20.57 \text{ L/min}$$

## INSTALLATION REQUIREMENTS

1. All installation work must be performed by trained, qualified contractors or technicians.

### WARNING

ALL ELECTRICAL WIRING MUST BE IN ACCORDANCE WITH NATIONAL ELECTRIC CODE AND LOCAL ELECTRIC CODES, ORDINANCES, AND REGULATIONS.

### WARNING

OBSERVE ELECTRIC POLARITY AND WIRING COLORS. FAILURE TO OBSERVE COULD CAUSE ELECTRIC SHOCK AND/OR DAMAGE TO THE EQUIPMENT.

### CAUTION

This unit can only be used for its intended design as described in this manual. Any internal wiring changes, modifications to the circuit board, modifications or bypass of any controls, or installation practices not according to the details of this manual will void the product warranty, the ETL/Intertek certification, and manufacturer product liability. Electro Industries, Inc., cannot be held responsible for field modifications, incorrect installations, and conditions which may bypass or compromise the built-in safety features and controls.

2. This installation manual and Mini-Boiler products relate only to the addition of the Mini-Boiler to the hydronic system. The owner/ installer assumes all responsibility and/or liability associated with any needed installation of the gas/oil boiler, pump, plumbing, system design, hydronic systems or backup gas/oil boiler, etc. Any instructions or comments made within this manual (or factory phone assistance) relating to the gas/oil furnace are provided as comments of assistance and “helps” only.

### CAUTION

Hazards or unsafe practices could result in property damage, product damage, severe personal injury and/or death.

3. Remember, safety is the installer’s responsibility, and the installer must know this product well enough to instruct the end user on its safe use. Safety is a matter of common sense - - a matter of thinking before acting. Professional installers have training and experienced practices for handling electrical, sheet metal, and material handling processes.

## ELECTRIC SUPPLY

Model	Volts	Phase	kW	Btu/h	Amps	CB	Element	
							Mod 1	Mod 2
EMB-M2-01-120-1	120	1-60 Hz	1.4	4,777	11.67	–	1	–
EMB-M2-03-120-1	120	1-60 Hz	3.0	10,236	25	–	1	–
EMB-M2-05-240-1	240/208	1-60 Hz	5.0/3.8	17,060/12,795	20.8/18.0	30A	1	–
EMB-M2-07-240-1	240/208	1-60 Hz	7.0/5.3	23,885/17,913	29.2/25.2	45A	1	(1)
EMB-M2-09-240-1	240/208	1-60 Hz	9.0/6.8	30,709/23,885	37.5/33.7	60A	1	(1)
EMB-M2-12-240-1	240/208	1-60 Hz	12.0/9.0	40,945/30,709	50.0/43.3	45A + 45A	1	1
EMB-M2-15-240-1	240/208	1-60 Hz	15.0/11.3	51,182/38,386	62.5/54.1	45A + 45A	1	1
EMB-M2-18-240-1	240/208	1-60 Hz	18.0/13.5	61,418/46,063	75.0/64.9	60A + 60A	1	1



## CLEARANCES

	MINIMUM CLEARANCE		SUGGESTED MINIMUM SERVICE CLEARANCE	
LEFT	1 INCH	26 MM	12 INCHES	305 MM
RIGHT	1 INCH	26 MM	12 INCHES	305 MM
BACK	0 INCHES	0 MM	0 INCHES	0 MM
FRONT	1 INCH	26 MM	21 INCHES	534 MM
TOP	1 INCH	26 MM	14 INCHES	356 MM
BOTTOM	1 INCH	26 MM	14 INCHES	356 MM
<b>SURROUNDING AMBIENT TEMPERATURE MUST NOT EXCEED 90°F/32°C</b>				

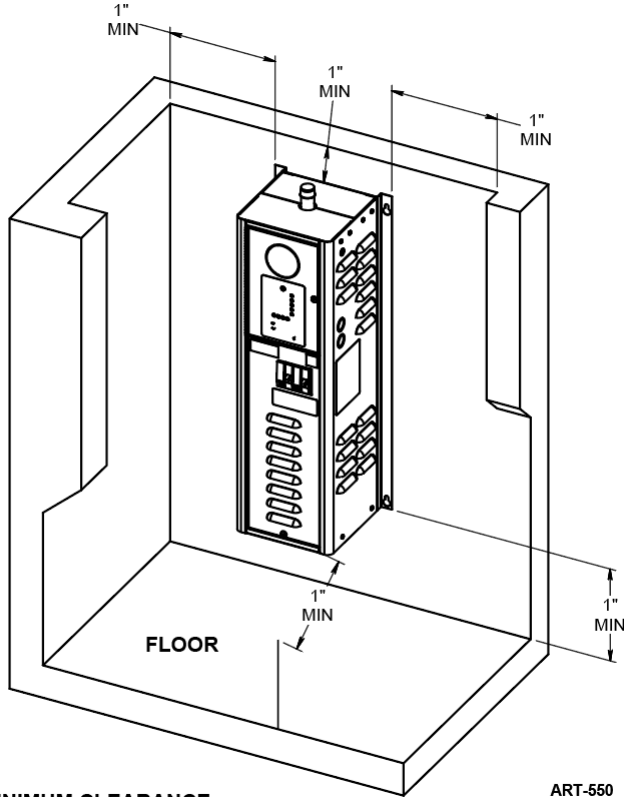

**MINIMUM CLEARANCE**

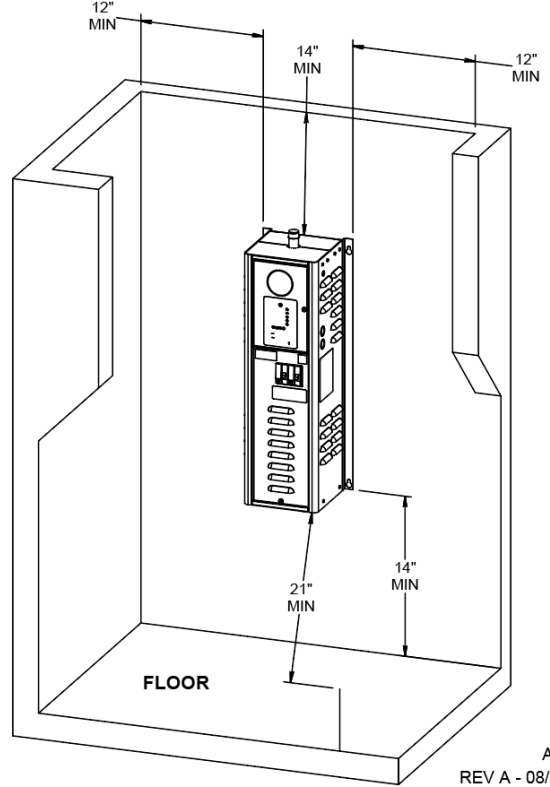

**SUGGESTED MINIMUM SERVICE CLEARANCE**

## MECHANICAL INSTALLATION

### CAUTION

Electro Industries Inc. requires the use of dielectric isolation between the boiler vessel supply and return piping when the boiler is plumbed using copper or any other dissimilar metal. Damage to the vessel caused by galvanic corrosion voids Electro Industries' warranty.

Reference drawing BX306

The plumbing components and piping layout shown on drawing BX306 has been very carefully picked and should be plumbed as shown. When following this diagram, the water fill procedure becomes very simple and almost guarantees the removal of all air or prevents air locking problems. Experienced hydronic heating installers may be able to eliminate components such as regulated fill valve, check valve, temperature gauge, etc., but the inclusion of these components guarantees installation and initial operating success.

The key mechanical components required include:

- **Boiler/Plumbing Kit Placement** – This model series is wall hung and the vessel must be vertical.
  - The plumbing kit items are located adjacent to the boiler housing itself as shown on drawing BX306.
  - For future servicing, the unit itself must be installed a minimum of 18” above the floor. The elements are screwed in from the bottom.
  - Allow adequate space for cover removal and maintenance.
- **Expansion Tank** – As a closed loop hydronic heating system, an expansion tank is required.
- **Temperature/Pressure Gauge** – For convenient monitoring a temperature and pressure gauge on the outlet (supply) is factory installed, facing the front of the boiler. For full observation of the system, installing one on the inlet (return) is desirable.
- **Pressure Safety Valve** - This is required at the hot outlet and is furnished as a **loose** component with the boiler unit itself. Failure to install the provided 30 PSI pressure relief valve as shown voids warranty and product listing.

Add the necessary pipe extension from the relief valve to the floor to prevent water damage on this unit or surrounding area.

- **Gate Valve/Drain Valve** - These are for servicing and easy fill purposes.
- **Circulating Pump** - Depending upon system lift and system loop resistance (feet of head), the proper circulating pump is required to guarantee the minimum GPM flow as specified on the cover sheet.

**Comment:** Circulator pump should “pump away from” the expansion tank.

- **Air Vent Relief** – The boiler system air vent should be installed at the highest point of the boiler piping. For multi-level applications where the heat emitters are several feet above the boiler, additional air vents may be required at those upper levels to effectively remove all the air from the system.
- **Building Water Supply Connection** – Reference drawing BX306, note 4, some local building codes require sophisticated check valve or anti-siphon check valve when the hydronic heating system is permanently connected to the domestic water system. The intent of this connection is temporary and for fill purposes only. The installer has the responsibility of complying with local building codes.

## ELECTRICAL HOOKUP

Reference drawing BH311

### **WARNING**

DISCONNECT ALL ELECTRICAL POWER BEFORE ELECTRICALLY CONNECTING OR SERVICING THE UNIT. FAILURE TO DISCONNECT THE ELECTRICAL POWER BEFORE WORKING ON THIS PRODUCT CAN CREATE A HAZARD LEADING TO PERSONAL INJURY OR DEATH.

1. **Panel breaker sizes** – based upon the installed unit capacity, cover page shows model number/amps/kW, service from appropriate size panel breaker based on NEC code.
2. The larger EMB-M models include a factory provided circuit breaker. This **qualifies** for a local disconnect at the product or appliance.
3. **240/208-Volt Power Source** – route and install the proper current carrying conductors, suggested by local codes, from service panel fuse or circuit breaker. Nameplate shows current & KW rating. Use only copper wire within this unit enclosure or at the circuit breaker connection.

The source is either from the standard service panel or may be part of an off-peak separately metered panel/CT metered enclosure. Consult with local utility if questions on off-peak installations.

### **WARNING**

USE ONLY COPPER WIRE FOR CONNECTION TO THE CIRCUIT BREAKER TERMINALS AND INSIDE THIS PRODUCT'S CABINET.

### **WARNING**

TO AVOID THE RISK OF ELECTRIC SHOCK OR DEATH, WIRING TO THE UNIT MUST BE PROPERLY GROUNDED. FAILURE TO PROPERLY GROUND THE UNIT CAN RESULT IN A HAZARD LEADING TO PERSONAL INJURY OR DEATH.

**NOTE:** This model series is designed and equipped for 240-volt residential single phase. If this unit is used on 208-volt, energy capacity is reduced by approximately 25%. The installed transformer has a primary tap for 208-volt. Rewire internal transformer so the boiler is using this primary tap for 208-volt applications.

4. **Circulating Pump** – the orange pigtail wires, at the corresponding zone cube relay, represent a switch closure (see drawing – 10-amp maximum) to operate the circulating pump motor. **Voltage for the pump must come from a separate source.** Wiring entrance must be through the left knockout, do not combine with thermostat cable or other control wiring.
5. **Operating Thermostat** – this Mini-Boiler has two thermostat connections designed to be used for one or two zone applications. Each zone will independently operate its zone pump relay. For single thermostat or external zone operating relay use thermostat connection labeled Zone 1. Temperature set point for Zone 1 is adjusted by using the temp set point dial on the front control panel of the boiler. For two zone applications simply, connect two independent thermostats or end switches to Zone1 and Zone 2. Zone 2 temperature control is adjusted on the inside of the control board. See “ZONE 2 TEMPERATURE SELECTION”.
6. Examples of thermostats that are compatible with this boiler include:
  - **Standard Mechanical** – connect to control board “R” and “W”. **IMPORTANT** – set thermostat internal heat anticipator to 0.2.
  - **Wi-Fi Thermostats** – most brands of Wi-Fi thermostats will work with the EMB-M Mini-Boiler. Wiring connections will typically be R-W-C.

- **Slab Thermostat** – 3-wire connection required.  
R to R, W to W, C to C, green to ground
  - **Power robbing thermostats** – power robbing thermostats can be used with the EMB-M Mini-Boiler models depending on thermostat brand and power consumption.
7. **Load Management Interrupt Control (LMC)** – this Mini-Boiler product has been pre-wired and designed for a power company load management receiver connection. This should not be altered in any manner! If load management is not used, simply leave the terminal labeled “load man” jumped. When connecting to load management observe the following:
- A. Remove jumper from load man terminal.
  - B. Insert two wires at load man and extend to the power company load control device.
- As shipped, this unit is only equipped for off-peak = N.C. logic. If reversed logic is required, contact the factory for modification.
- Optional 1**– if the power company disconnects 240V for load control, please reference BH029 for special wiring requirements.
8. **Zone Valve** – the installer may elect to totally wire in the zone valves where paralleling the end switches activate the control board R and W for the respective zone. The EMB-M Series has a 40VA, 24-volt transformer which is capable of driving 1 or 2 external zone valves depending on valve power requirements. It is required to parallel the end switches to activate the control board R and W for the respective zone when zone valves are used to prevent deadlock and water overheating in a zero flow scenario.
9. **Inspection/final check** – Verify all electrical connections are tight (including factory connections), verify there is proper spacing between all power and electrical wire/terminals, and verify top high limit manual reset is “in”. During shipping freight vibration there are times when the boiler vessel top manual reset high limit is “popped out”.

## WATER ADDITIVES

1. Water treatment is strongly suggested to prevent scale deposits, corrosion from acids, oxygen, and other harmful elements within the specific water supply. Unless the source water is unusually poor and/or rust elements, additives are not required for use, but strongly suggested. Failure to manage the proper water voids the element warranty.
2. Impurities within a closed loop hydronic boiler are considerably less damaging than the typical domestic water heater as new impurities are not introduced constantly. In a closed loop electric boiler, the initial filling of the water should be as pure as possible. As a closed system, this “pure water” becomes the operating mode.
3. If there is an auto fill connected from the domestic water source to the boiler system, it is recommended the water source as shown on drawing BX306 comes through the household water softener. If additives are required, use the recommendations and source from your local professional plumber specializing in hydronic heating systems.
  - It is the installer or user’s responsibility to verify water quality and maintain acceptable water quality throughout the life of this product. As a requirement the following water properties must be considered:
    - i. Hardness (ppm): 0-10
    - ii. pH: 7.5-10
    - iii. Iron Content (ppm): 0-20
    - iv. Oxygen Content (ppm): 0
    - v. Total Dissolved Solids: 0-5000

### **WARNING**

FAILURE TO MAINTAIN THE PROPER WATER QUALITY INCREASES THE RISK OF PREMATURE ELEMENT FAILURE OR POOR ELEMENT PERFORMANCE AND WILL VOID THE ELEMENT WARRANTIES.
--

4. Up to a 50/50 propylene glycol mixture is acceptable for use in these boilers in cold weather applications.

## WATER FILL PROCEDURE

The following procedure only applies to the prepackaged plumbing kit and/or when the system is plumbed exactly as shown on drawing BX306.

1. Do not apply 240/208 volt power during water fill sequence.
2. Connect the temporary household water supply source (probably hose connection) to the "supply water connection" input.  
**NOTE:** If supply water connection is permanent, some local building codes may require special anti-siphon check valve, PRZ check valve, or equivalent between the Mini-Boiler fill regulator and the domestic water source or the city water connection.
3. Connect a drain hose to lower hose bib, "drain valve".
4. **Open** "drain valve" and **close** "inlet gate valve" (between drain valve and boiler bottom inlet).
5. Verify "top gate valve" is **open**.
6. **Open** "water supply valve" and **open** household water supply source.  
This may be at normal household pressure (40 to 60 PSI), the auto-fill valve regulator keeps the hydronic loop at its proper low pressure.
7. Allow system to circulate, discharging through drain valve, **for at least 10 minutes**.
8. Put your ear against the metal pipe and listen for air bubbles. If the water flow is consistent and quiet, the system is probably purged and water filled.
9. **Close** the "drain valve". **Open** the "inlet gate valve".
10. The cold system pressure at the gauge should be approximately 10 to 14 PSI.
11. **Close** "water supply valve" and disconnect water supply.
12. Optional – The circulating pump can be energized during this fill operation by having the 240/208-volt power main source breaker off and simply jumpering the 2 screw terminals for the pump wire connection.

## AQUASTAT OPERATION

Determine the design or anticipated outlet temperature. If this is a radiant floor system this typically could be as low as 110°. If it is staple-up or water coil, satisfactory operation may be at 140° to 160°. If this is baseboard or radiators, start with 170° and during very cold weather this may need to be 180°.

The front temperature set point is selected by a small screwdriver dial switch.

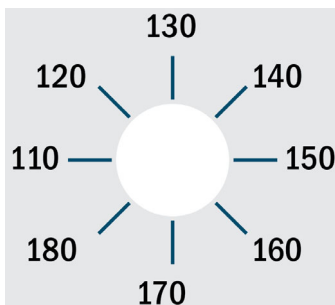

## WARMFLO HI TEMPERATURE MODE & EMERGENCY HEAT

Adding a jumper on the header marked “E HEAT” on the control board automatically sets the temperature setpoint to maximum 180 °F. See image to the right. In other words, with the jumper installed, the system will command full on to reach 180 °F and control to that temperature. Note: Zone Call is still required. To test functionality, jumper R → W with E Heat jumper installed.

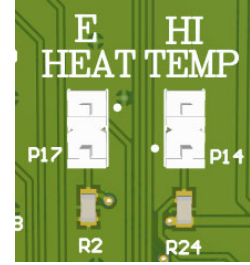

Adding a jumper on the header marked “HI TEMP” on the control board automatically shifts each temperature setpoint up 20°F as follows:

- |               |               |
|---------------|---------------|
| 90°F → 110°F  | 130°F → 150°F |
| 100°F → 120°F | 140°F → 160°F |
| 110°F → 130°F | 150°F → 170°F |
| 120°F → 140°F | 160°F → 180°F |

**Note:** Basic 24V power must be present for this control board function to work.

### Flow Switch Statement

A flow switch is **not** included with the boiler. However, one can be added to the LMC circuit. Simply place the field provided flow switch in series with this circuit.

## ZONE 2 TEMPERATURE SELECTION

The following DIP switch positions represent the Zone 2 temperature selection. To activate the selection of Zone 2 Temperatures, DIP Switch #4 needs to be turned ‘ON’ as shown in following figure. See the following image with location of the DIP Switch on the control board inside the front cover.

### ⚠ CAUTION

ELECTROCUTION IS A RISK INSIDE THE ENCLOSURE OF THE BOILER. ALWAYS TURN POWER OFF TO THE BOILER PRIOR TO MODIFYING THE ZONE 2 TEMPERATURE SETPOINT OR ACTIVATION LOCATED INSIDE THE BOILER. HAZARDS OR UNSAFE PRACTICES COULD RESULT IN PROPERTY DAMAGE, PRODUCT DAMAGE, SEVERE PERSONAL INJURY AND/OR DEATH.

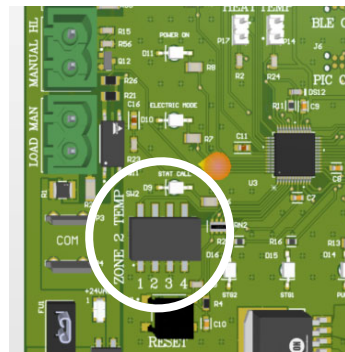
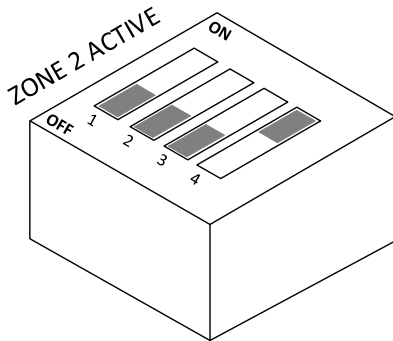

**ZONE 2 - 90°F**

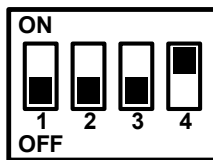

**ZONE 2 - 100°F**

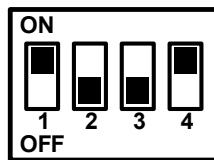

**ZONE 2 - 110°F**

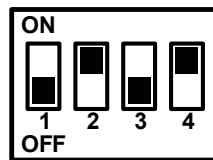

**ZONE 2 - 120°F**

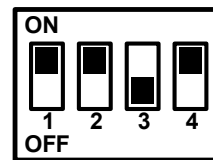

**ZONE 2 - 130°F**

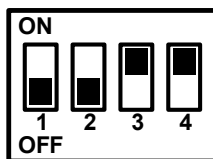

**ZONE 2 - 140°F**

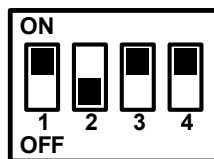

**ZONE 2 - 150°F**

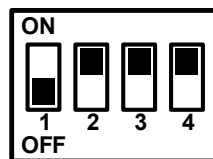

**ZONE 2 - 160°F**

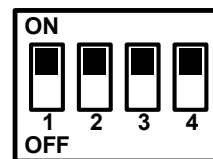

## OPERATIONAL TIPS

1. Indicator lights – there are nine indicator lights on the front cover. Figure 1 under Aquastat Operation is a reproduction of the front decal giving definition and information for using these indicator lights.
2. **Boiler Power** green LED indicates 24-volt is present on the control board and is continuous on. Off could mean no 240/208-volt power, open fuse, or bad transformer. It also indicates supply sensor condition (solid = good, pulse = faulty).
3. 240/208-volt element power current flow can only be measured when the external operating thermostat is calling for heat. Stage 2 will depend upon the temperature differential at the sensor in the supply pipe, see sequence (assumes off-peak mode).
4. The operating thermostat heat call can be verified by the red LED marked **Thermostat Call** located on front cover. Both Zones 1 and 2 thermostat heat calls activate this LED. The ‘R’ to ‘W’ heat call is indicated on the control board in the upper left when the upper door is opened. See image to the right.
5. **Electric Mode** yellow LED is on when the boiler is not being load controlled (blue wires closed).
6. The **205°F Manual Reset Limit** red LED is on when the vessel top manual hi-limit switch has opened due to high temperature.
7. The **190°F Auto Reset Limit** red LED is on when the vessel top auto hi-limit switch has opened due to high temperature.
8. The pump outputs on the control board provide contact closure to the pump relays under the lower chassis door (See image to the right). Ensure the pump connected does not exceed the rating of the relay. Power must be removed to open the chassis doors for external wiring of the pumps. EMB-M2\* models contain two pump relays.
9. At outlet temperatures of approximately 160° F, the maximum operating system pressure should be approximately 18 PSI (124 kPa). If the PSI (or kPa) increase from cold water to operating hot water is more than approximately 3 to 4 PSI increase (20.6 to 27.5 kPa), the expansion tank is too small, or there is air in the system.
10. At the top of the vessel is a manual reset, 205° F, primary manual hi-limit. This is behind the upper control board cover, at the top of the vessel. In the middle of the manual reset wires there is a tab between the wire terminals. This is the reset button. With power off and the device cooled, press the tab in to reset. \*Seek professional maintenance before restarting boiler.

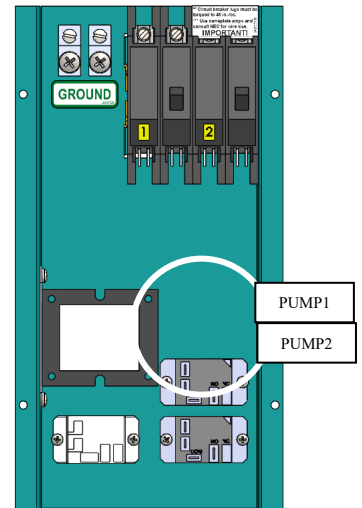
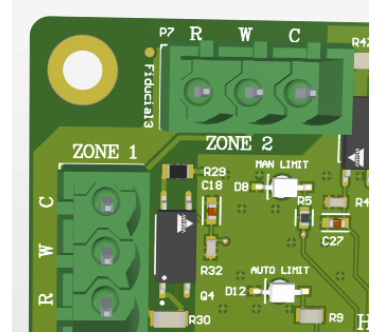

### 205°F Manual Reset



Press this to reset

### **WARNING – HIGH V**

MUST SHUT OFF HIGH VOLTAGE BEFORE ATTEMPTING TO RESET.

### **WARNING**

PROFESSIONAL MAINTENANCE IS REQUIRED WHEN THE MANUAL RESET TRIPS. THE SYSTEM IS LIKELY TO TRIP AGAIN IF THE UNDERLYING ISSUE IS NOT FIXED.

11. Check for water leaks and repair as required.
12. If flow seems to be a concern, determine both inlet and outlet water temperature and apply GPM (L/min) formula detailed in previous section “Information/Water Flow Calculations”.



## TROUBLESHOOTING HELPS

### Front Cover LED Indications

- The two red LEDs labeled “MANUAL RESET LIMIT” and “AUTO RESET LIMIT” are an indication of whether the manual or auto temperature limits have failed.
- The green LED labeled “BOILER POWER” is an indication of whether the boiler control board is powered/unpowered.
- The yellow LED labeled “ELECTRIC MODE” is an indication of if the power company is allowing electric boilers to operate (led ON) or not (led OFF).
- The red LED labeled “THERMOSTAT CALL” is an indication of whether a thermostat call is active/inactive.
- The two red LEDs labeled “STG1” and “STG2” are an indication of whether elements of the boiler are on/off. The two green LEDs labeled “PUMP1” and “PUMP2” are an indication of whether the zone pump contactors are on/off.

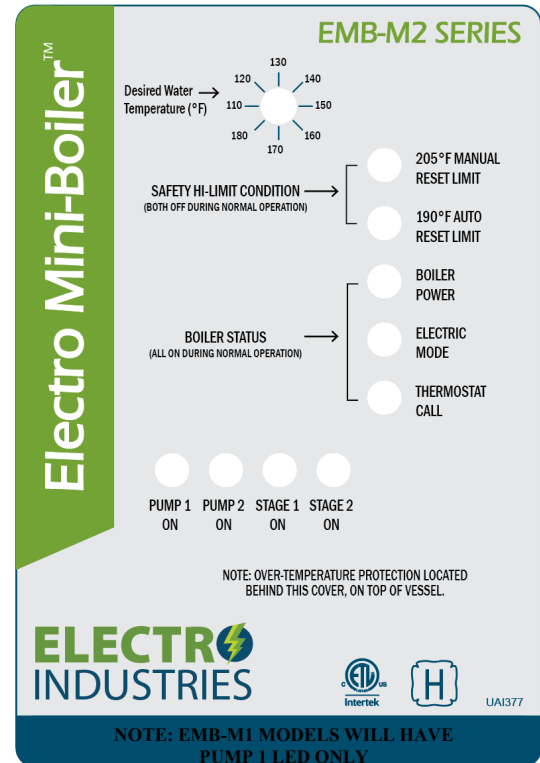

### Sequence EMB-M\*-\*-1

- At heat call, pump(s) turn on from the control board Blue and/or Blue/White wires connected to the pump relay(s). In a single zone **modulating** boiler model (EMB-M1\*) only Pump 1 is activated. In two zone boiler model (EMB-M2\*) the pump that correlates to the Zone (1 or 2) is activated.
- Elements remain off for 30 seconds.
- In this series, if the supply sensor is detecting supply water temperature below the setpoint, the elements turn on according to the PID control algorithm output (i.e. 0-100%).
- As the outlet temperature approaches the set point, the control algorithm automatically modulates the elements to match the BTU load.
- Above the set point elements 1 and 2 modulation are reduced according to the control algorithm.
- The modulation of the elements continues to adjust to optimize element usage based on realized heating demand.

**Mechanical auto hi-limit, top vessel surface mount, automatic reset** – this opens at  $190 \pm 5^\circ\text{F}$ , which opens the red/white wire indication to the board. This opens all 24V element relay power thus preventing element activation power. This can be monitored by the “Auto Reset” front indicator light. As the water cools to approximately  $160^\circ\text{F}$  it should self-reset and restart.

**Mechanical manual hi-limit, top vessel surface mount, manually reset** – surfaced mounted to the top of the vessel, opens at  $205^\circ\text{F}$ . This opens all 120V/240V element power thus opening all power conductors to the elements. The observed action is realized through the “Manual Reset” front indicator light. Note: the boiler will not operate until the unit cools down and this limit is manually reset.

In the middle of the manual reset wires there is a tab between the wire terminals. This is the reset button. With power off and the device cooled, press the tab in to reset.

**Note:** In typical abnormal operation the auto hi-limit will always trip prior to the manual limit. In general if the system is properly setup, the manual limit should never trip.

## AVAILABLE, ELECTRO INDUSTRIES, INSTALL PARTS OR KITS

EMB-PK	PREFERRED INSTALLATION PLUMBING KIT, 3/4"
EMB-P2	PUMP KIT 1/25HP CIRCULATOR
EB-PK-M	PREFERRED INSTALLATION PLUMBING KIT FOR 15 & 18 KW
5585	CIRCULATING PUMP, 120V, 1/25 HP
5586	CIRCULATING PUMP, 120V, 1/6 HP
5582	1" FLANGE W/VALVE FOR 15 & 18 KW
5590	EXPANSION TANK 40K BTU 2.1 GALLON
5591	EXPANSION TANK 135K BTU 4.5 GALLON
5576	AIR ELIMINATOR 3/4" ROLLAIRTROL
5595	AIR ELIMINATOR 1" ROLLAIRTROL
5453	VALVE RELIEF 30 PSIG .75" NPT MALE
5456A	GAUGE PRES/TEMP 75 PSI/320DG F .25"
EMBM5625	REPLACEMENT CONTROL BOARD
5402KIT	THERMISTOR, SUPPLY TEMP
6206KIT	THERMISTOR, OUTDOOR TEMP, 25 FT
4038KIT	TRIAC MODULE, 50A
4038-75KIT	TRIAC MODULE, 75A
5128C	RELAY, 24VDC, 40A
5541	TRANSFORMER, 24V/40VA

# "BASIC" MECHANICAL PIPING DIAGRAM

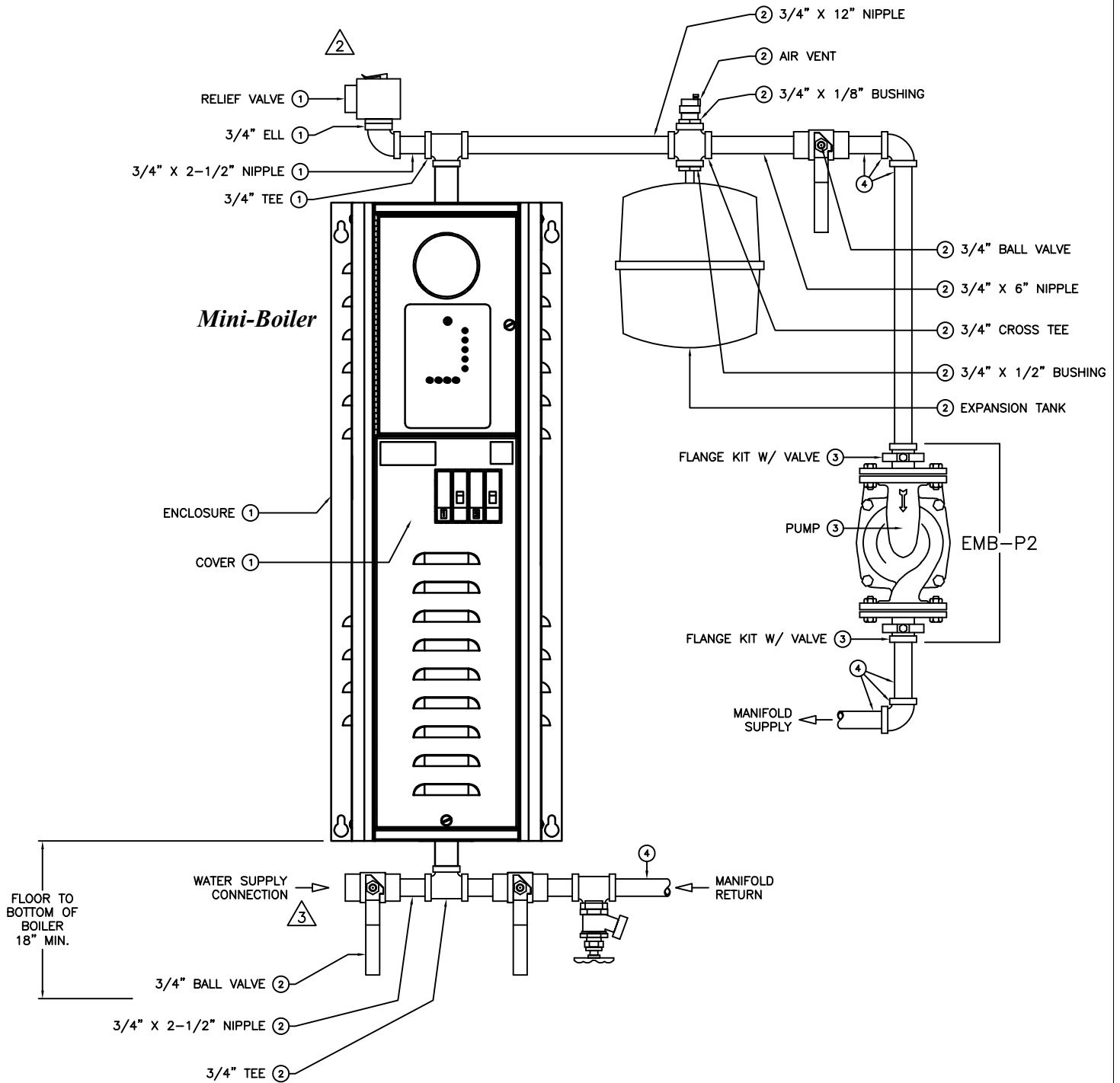

**LEGEND**

- ① COMPONENTS INCLUDED WITH EMB-R\*-\*-1 and EMB-M\*-\*-1
- ② COMPONENTS INCLUDED WITH EMB-BK KIT
- ③ COMPONENTS INCLUDED WITH EMB-P2 (PUMP) KIT
- ④ COMPONENTS NOT INCLUDED, SHOWN FOR REFERENCE ONLY

**NOTES:**

1. INSTALLATION KIT (PART NUMBER EMB-BK) INCLUDES ALL PIPING PARTS (LESS PUMP & FLANGES) EXTERNAL TO THE 9.5" x 30" x 7" ENCLOSURE.
2. ADD NECESSARY DRAIN PIPE.
3. SEE INSTRUCTION MANUAL FOR PRESSURE CONCERNS AND MAY NEED BACKFLOW PREVENTER.

# "PREFERRED" MECHANICAL PIPING DIAGRAM

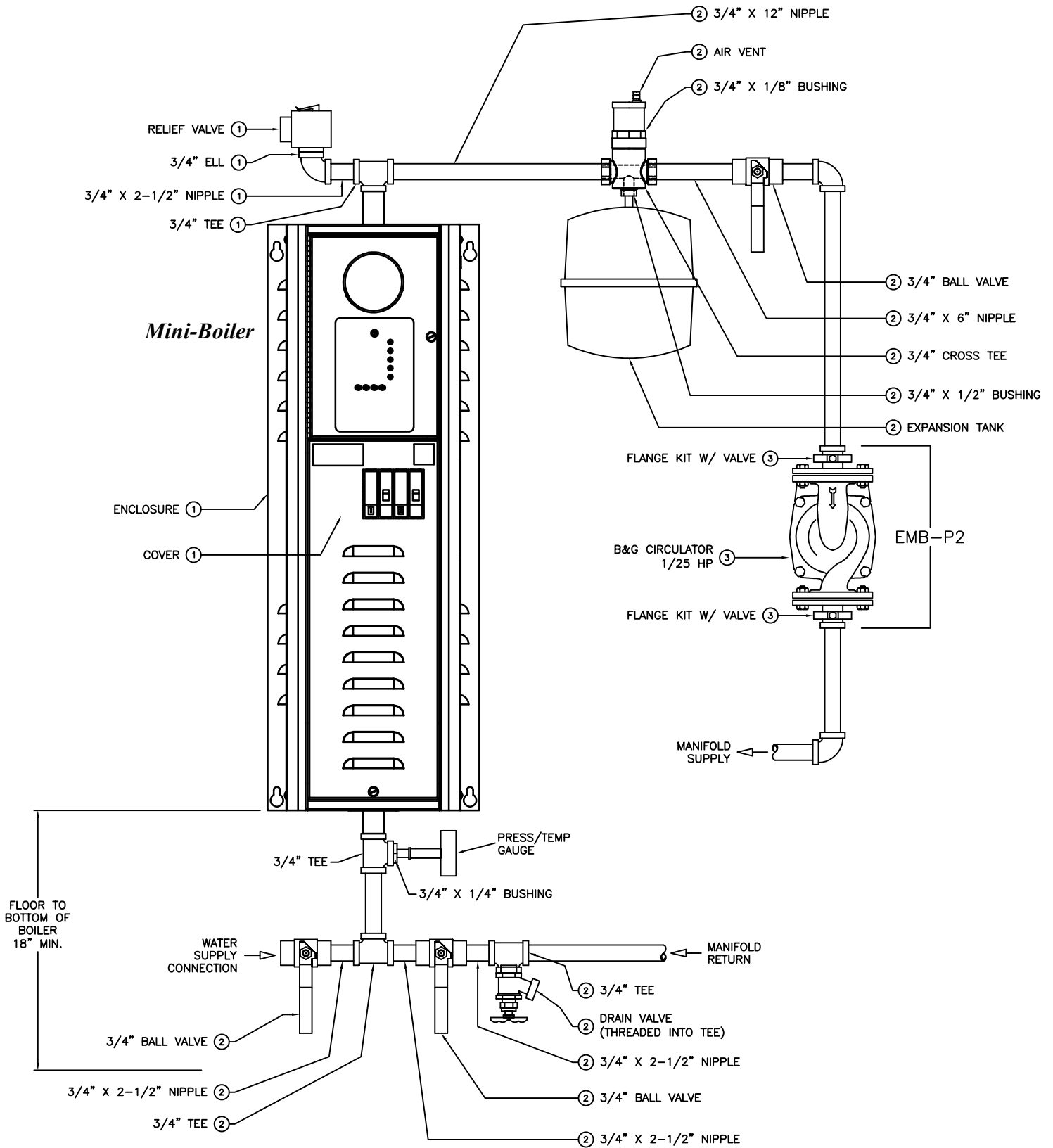

## LEGEND

- ① COMPONENTS INCLUDED WITH EMB-R\*-\*-1 and EMB-M\*-\*-1
- ② COMPONENTS INCLUDED WITH EMB-PK KIT
- ③ COMPONENTS INCLUDED WITH EMB-P2 (PUMP) KIT
- ④ COMPONENTS NOT INCLUDED, SHOWN FOR REFERENCE ONLY



# MINI-BOILER BASIC HOOKUP (EMB-R\*-\*-1, EMB-M\*-\*-1)

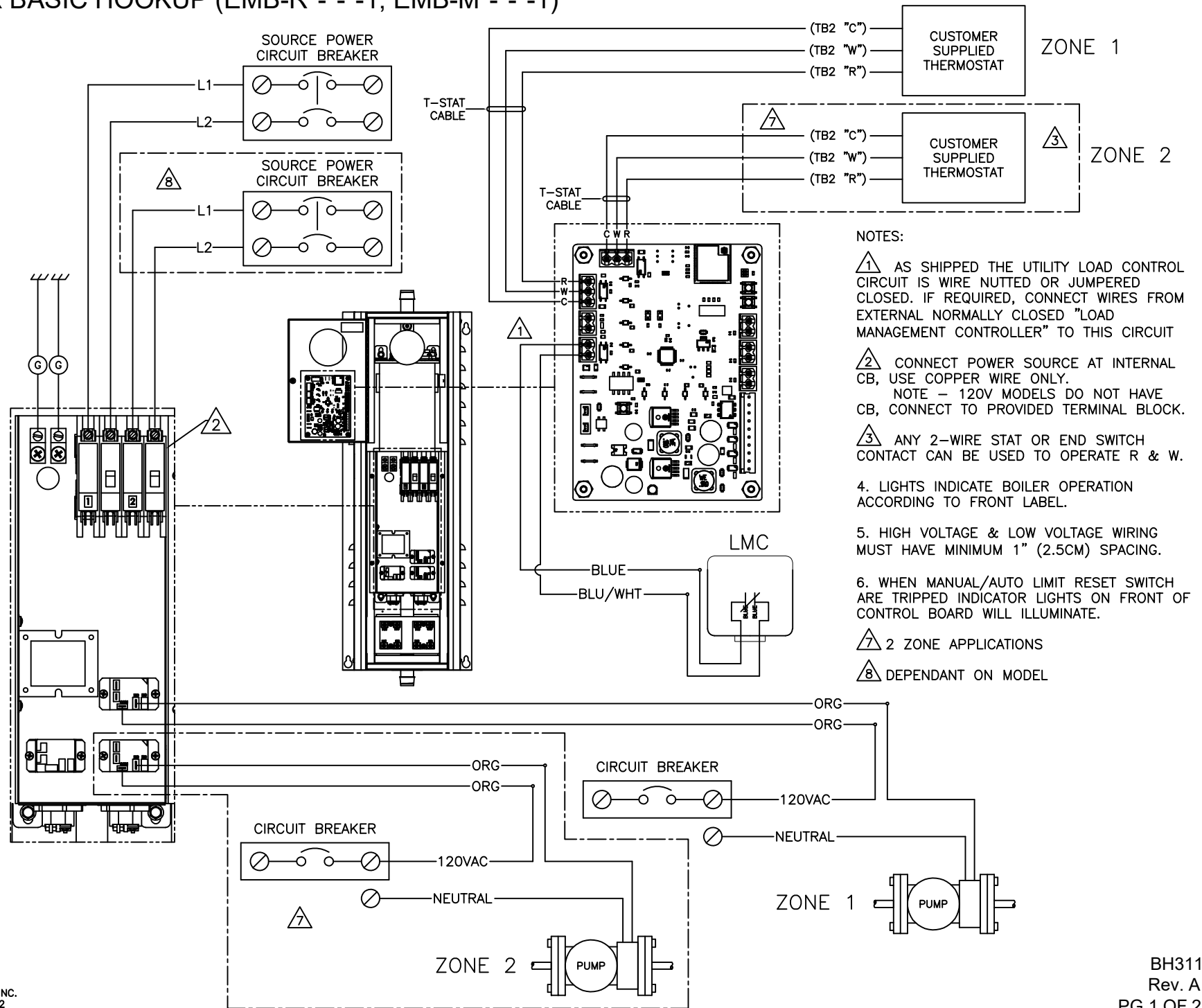

**NOTES:**

- ⚠️ 1 AS SHIPPED THE UTILITY LOAD CONTROL CIRCUIT IS WIRE NUTTED OR JUMPERED CLOSED. IF REQUIRED, CONNECT WIRES FROM EXTERNAL NORMALLY CLOSED "LOAD MANAGEMENT CONTROLLER" TO THIS CIRCUIT
- ⚠️ 2 CONNECT POWER SOURCE AT INTERNAL CB, USE COPPER WIRE ONLY.  
NOTE - 120V MODELS DO NOT HAVE CB, CONNECT TO PROVIDED TERMINAL BLOCK.
- ⚠️ 3 ANY 2-WIRE STAT OR END SWITCH CONTACT CAN BE USED TO OPERATE R & W.
- 4. LIGHTS INDICATE BOILER OPERATION ACCORDING TO FRONT LABEL.
- 5. HIGH VOLTAGE & LOW VOLTAGE WIRING MUST HAVE MINIMUM 1" (2.5CM) SPACING.
- 6. WHEN MANUAL/AUTO LIMIT RESET SWITCH ARE TRIPPED INDICATOR LIGHTS ON FRONT OF CONTROL BOARD WILL ILLUMINATE.
- ⚠️ 7 2 ZONE APPLICATIONS
- ⚠️ 8 DEPENDANT ON MODEL

Rev A 08/02/22: Released

# MINI-BOILER HOOKUP (EMB-R\*-\*-1, EMB-M\*-\*-1)

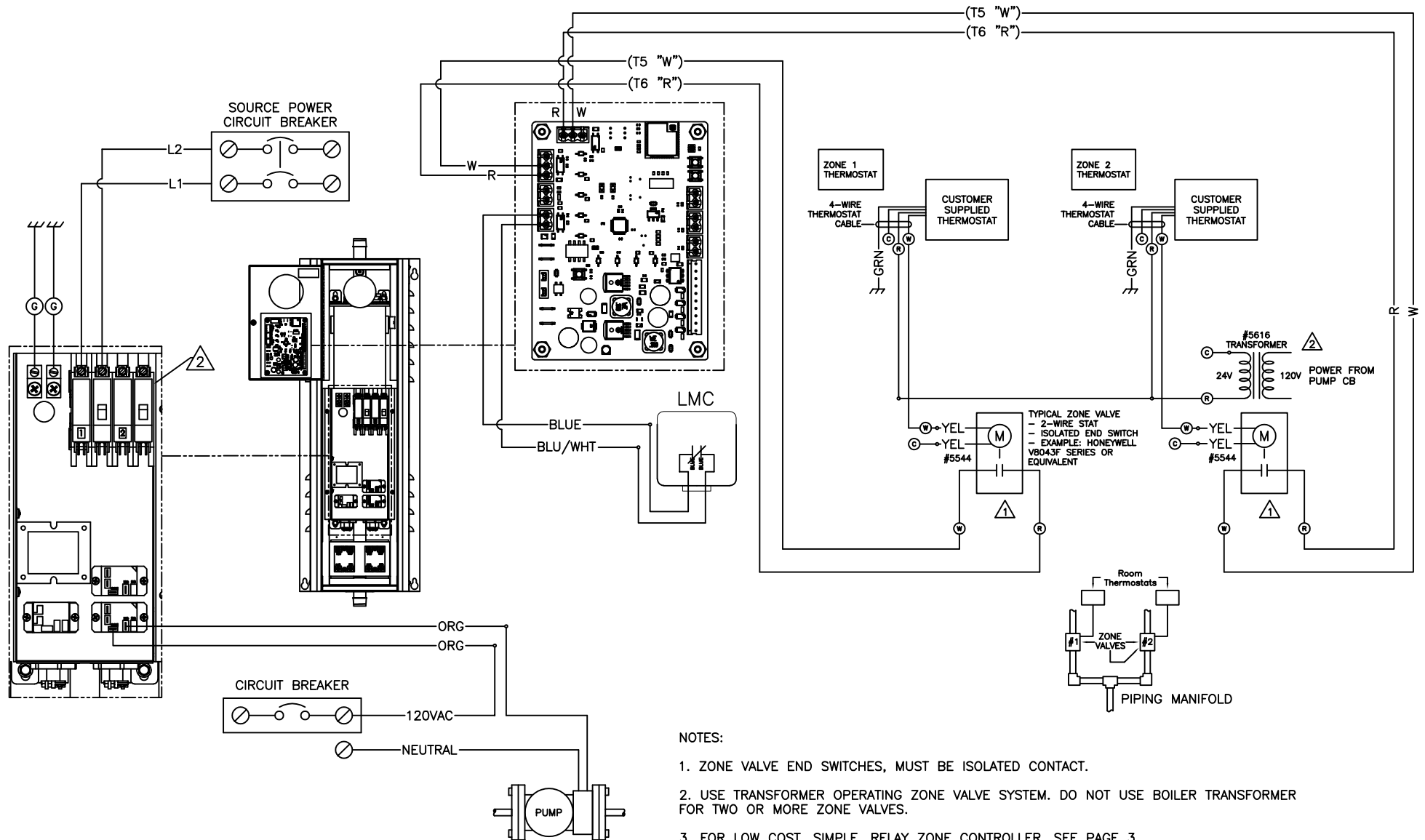

**NOTES:**

1. ZONE VALVE END SWITCHES, MUST BE ISOLATED CONTACT.
2. USE TRANSFORMER OPERATING ZONE VALVE SYSTEM. DO NOT USE BOILER TRANSFORMER FOR TWO OR MORE ZONE VALVES.
3. FOR LOW COST, SIMPLE, RELAY ZONE CONTROLLER, SEE PAGE 3.

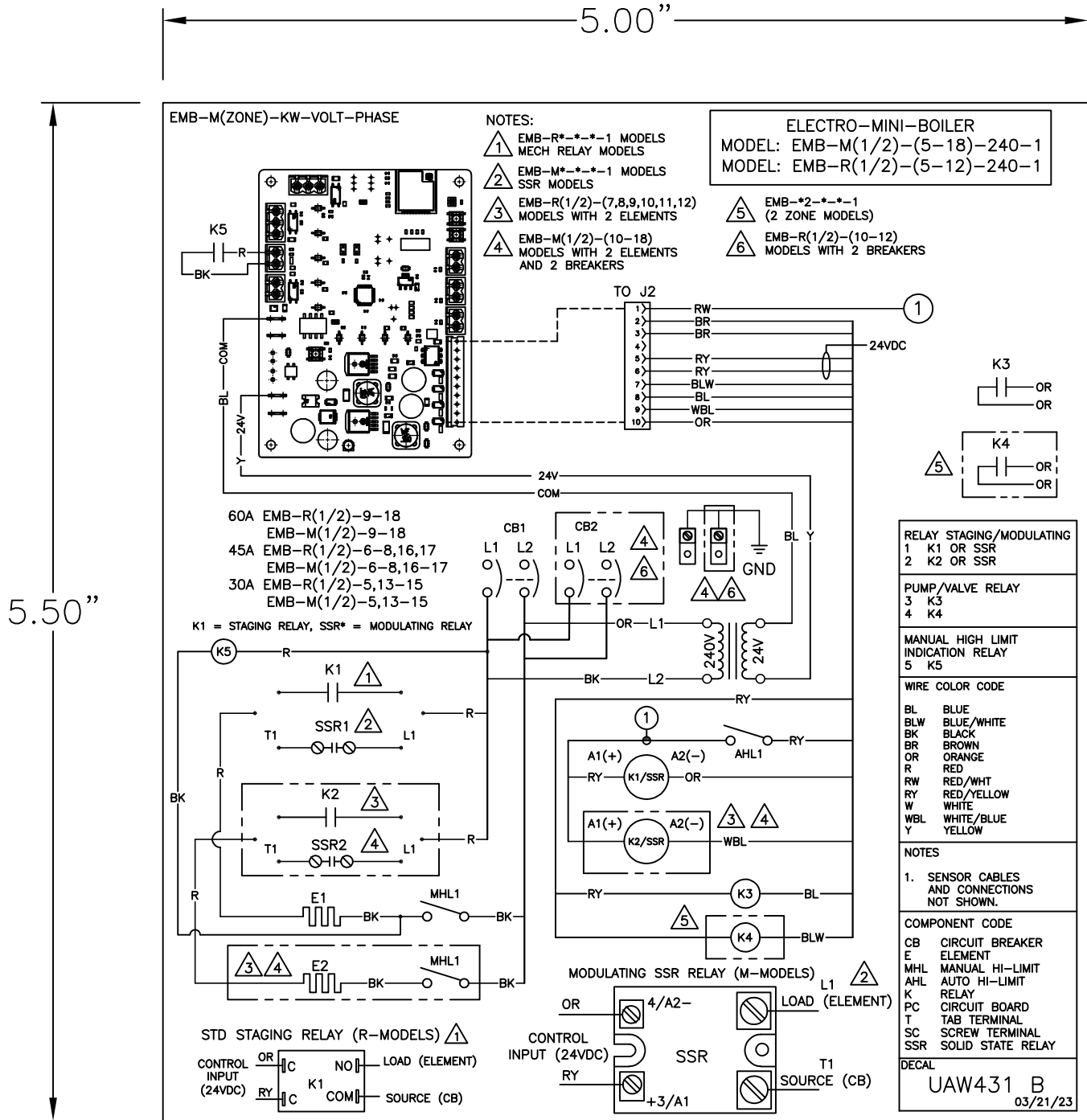

- NOTES:  
 1. SIZE = 5.5" X 5"  
 2. COLOR = BLACK ON WHITE  
 3. MATERIAL = POLY WITH ADHESIVE AND LAMINATE.

Rev. A 07/22/22: Released For Production.  
 Rev. B 03/21/23: Removed all 120V info.

PROPRIETARY AND CONFIDENTIAL NOTE: THE INFORMATION CONTAINED IN THIS DRAWING IS THE SOLE PROPERTY OF ELECTRO INDUSTRIES INC. ANY REPRODUCTION IN PART OR AS A WHOLE WITHOUT THE WRITTEN PERMISSION OF ELECTRO INDUSTRIES INC. IS PROHIBITED.	DESCRIPTION EMB-M(1/2)-(5-18)-240-1 EMB-R(1/2)-(5-12)-240-1 WIRING DECAL	ELECTRO INDUSTRIES, INC. MONTICELLO, MN 55362	SHEET 1/1	SCALE NTS	PART/MODEL NUMBER EMB-(M,R)
	DRAWN NP	CHECKED	APPROVED	DATE 07/22/22	REV/STATUS B

# BOILER ACCESSORIES

---

## ZONE CONTROLLER

This will simplify your wiring and make zoning applications much easier. In addition, enhanced communicating features have the ability to stage the electric boiler based upon the connected zone capacity.

### Standard Features

- Utility load control
- Terminal block wiring, visual wiring layout
- Indicator lights showing zone operation
- 24-volt, 40VA transformer 120/208/240 connection
- Fuse protection
- Priority option
- Dual temperature operation
- Applies to digital or standard thermostats
- Dial switch, select each zone capacity



### Pumps, Actuators, Valves

- EB-ZTA-1 - install within boiler cabinet
- EB-ZEA-1 - with enclosure and 40VA transformer
- EB-ZEA-2 - add additional 4, enclosure and 40VA transformer

### Pumps

- EB-ZEA8 - with enclosure and 40VA transformer for 8 zone pumps

### Zone Valves

- EB-ZTS-1 - install within boiler cabinet, encl. option
- EB-ZTS-2 - add additional 4, enclosure and 40VA transformer
- EB-ZES8 - with enclosure, no transformer, for 8 zone valves

---

## SWITCHING RELAY - EE-5051

This DPDT 24-volt switching relay provides a convenient solution to any AC or DC application.



- **Ideal for zone pumps**
- 24V coil
- 120V, 10A, contact sets
- Easy to wire and nicely packaged

---

## MULTI-BOILER - EB-C-STG5

Electrically connects between 2<sup>nd</sup> and 3<sup>rd</sup>, 3<sup>rd</sup> and 4<sup>th</sup>, etc.

### OTHER OPTIONS

- SOT-1 Switchover to standby, total run time
- 5701 Single feed bus for 2 CB's (SQ-D CB)
- 5702 Single feed bus for 3 CB's (SQ-D CB)
- EB-S-SB Dual boiler option for EB-S Series
- WF-ANZ7 WarmFlo<sup>®</sup> Analyzer, now applicable to WO and WA Series



**ELECTRO  
INDUSTRIES**

Monticello, Minnesota  
800.922.4138  
www.electromn.com



## TWO SUPPLY WATER TEMPERATURE REQUIREMENT

- Handled as the priority zone on multi-zone (EB-ZEA-1)
- Priority switch on, zone 1 active - TS boiler automatically changes to 150° (or selection 176°) supply water setting
- All other zones are held off
- With zone 1 satisfied or 60-minute timeout, the boiler automatically returns to the preset temperature and reacts to the other zones

Low Temp	High Temp
Radiant, slab	Radiant, staple up
Radiant, slab	Baseboard
Radiant, slab	Fan coil
Radiant, slab	Water heater, side arm
Radiant, slab	Hanging unit heater (garage, shop, etc.)

## INSTALLATION PLUMBING KITS

These installation kits provide the critical plumbing components needed for easy installation of the Electro-Boiler®. **In addition** to the items shown in the matrix below, each kit includes all necessary ball valves, drain valve, tees, elbows, nipples, bushings, couplings, etc. for direct connection to circulator pump and/or manifold.

Electro Industries' boilers come standard equipped with outlet temperature/pressure gauge, pressure relief safety valve, and when applicable, the WarmFlo electronic control sensors. These kits provide the additional components for easy installation:

Model	Application	Return Gauge	Expansion Tank	Air Vent
EMB-BK	All EMB Series		2.1 gal. (7.9 L), 40,000 Btu/h	Basic float type
EMB-PK	All EMB Series	✓	2.1 gal. (7.9 L), 40,000 Btu/h	Enhanced air separator, EAS
EB-PK-M	EB-MS, -MA, -MO Series	✓	4.5 gal. (17 L), 135,000 Btu/h	Enhanced air separator, EAS
EB-BK-TS	EB-S, -WA, -WO Series		4.5 gal. (17 L), 135,000 Btu/h	Basic float type
EB-PK-TS	EB-S, -WA, -WO Series	✓	4.5 gal. (17 L), 135,000 Btu/h	Enhanced air separator, EAS

## CIRCULATING PUMPS



**5585 - Mini-Boiler & 10 kW TS Series**

- 120V, 1/25 HP, maintenance-free wet rotor circulator
- Pump curve example - 5 GPM (19 L) @ 11 ft. of head (32.9 kPa)



**5586 - TS Series, Standard**

- 120V, 1/6 HP, maintenance-free oil lubricated circulator
- Pump curve example - 10 GPM (37.8 L) @ 20 ft. of head (50.8 kPa)



**5578 - 3/4" Pipe**

**5582 - 1" Pipe**

**5579 - 1-1/4" Pipe**

- Two flanges, with isolation valve

# Electro Industries, Inc. Residential Limited Product Warranty

Effective November 1, 2009

Electro Industries, Inc. warrants to the original owner, at the original installation site, for a period of two (2) years from date of original purchase, that the product and product parts manufactured by Electro Industries, Inc. are free from manufacturing defects in materials and workmanship, when used under normal conditions and when such product has not been modified or changed in any manner after leaving the plant of Electro Industries, Inc. If any product or product parts manufactured by Electro Industries, Inc. are found to have manufacturing defects in materials or workmanship, such will be repaired or replaced by Electro Industries, Inc. Electro Industries, Inc., shall have the opportunity to directly, or through its authorized representative, examine and inspect the alleged defective product or product parts. Electro Industries, Inc. may request that the materials be returned to Electro Industries, Inc. at owner's expense for factory inspection. The determination as to whether product or product parts shall be repaired, or in the alternative, replaced, shall be made by Electro Industries, Inc. or its authorized representative.

Electro Industries, Inc. will cover labor costs according to the Repair / Replacement Labor Allowance Schedule for a period of ninety (90) days from the date of original purchase, to the original owner, at the original installation site. The Repair / Replacement Labor Allowance is designed to reduce the cost of repairs. This Repair / Replacement Labor Allowance may not cover the entire labor fee charged by your dealer / contractor.

## **TWENTY YEAR (20) LIMITED WARRANTY ON BOILER ELEMENTS AND VESSELS**

Electro Industries, Inc. warrants that the boiler elements and vessels of its products are free from defects in materials and workmanship through the twentieth year following date of original purchase. If any boiler elements or vessels are found to have a manufacturing defect in materials or workmanship, Electro Industries, Inc. will replace them.

## **TWENTY YEAR (20) LIMITED WARRANTY ON SPIN FIN ELEMENTS**

Electro Industries, Inc. warrants that the spin fin elements of its products are free from defects in materials and workmanship through the twentieth year following date of original purchase. If any spin fin elements are found to have a manufacturing defect in materials or workmanship, Electro Industries, Inc. will replace them.

## **FIVE YEAR (5) LIMITED WARRANTY ON OPEN WIRE ELEMENTS**

Electro Industries, Inc. warrants that the open wire elements of its products are free from defects in materials and workmanship through the fifth year following date of original purchase. If any open wire elements are found to have a manufacturing defect in materials or workmanship, Electro Industries, Inc. will replace them.



Monticello, MN • 800.922.4138 • [www.electromn.com](http://www.electromn.com)

## CONDITIONS AND LIMITATIONS:

1. This warranty is limited to residential, single family dwelling installations only. Any commercial or multi-unit dwelling installations fall under the Electro Industries Commercial Limited Product Warranty.
2. Electro Industries, Inc. shall not be liable for performance related issues resulting from improper installation, improper sizing, improper duct or distribution system, or any other installation deficiencies.
3. If at the time of a request for service the original owner cannot provide an original sales receipt or a warranty card registration then the warranty period for the product will have deemed to begin the date the product is shipped from the factory and **NOT** the date of original purchase.
4. The product must have been sold and installed by a licensed electrician, plumbing, or heating contractor.
5. The application and installation of the product must be in compliance with Electro Industries, Inc. specifications, as stated in the installation and instruction manual, and all state, provincial and federal codes and statutes. If not, the warranty will be null and void.
6. The purchaser shall have maintained the product in accordance with the manual that accompanies the unit. Annually, a qualified and licensed contractor must inspect the product to assure it is in proper working condition.
7. All related heating components must be maintained in good operating condition.
8. All lines must be checked to confirm that all condensation drains properly from the unit.
9. Replacement of a product or product part under this limited warranty does not extend the warranty term or period.
10. Replacement product parts are warranted to be free from defects in material and workmanship for ninety (90) days from the date of installation. All exclusions, conditions, and limitations expressed in this warranty apply.
11. Before warranty claims will be honored, Electro Industries, Inc. shall have the opportunity to directly, or through its authorized representative, examine and inspect the alleged defective product or product parts. Remedies under this warranty are limited to repairing or replacing alleged defective product or product parts. The decision whether to repair or, in the alternative, replace products or product parts shall be made by Electro Industries, Inc. or its authorized representative.

## THIS WARRANTY DOES NOT COVER:

1. Costs for labor for diagnosis, removal or reinstallation of an alleged defective product or product part, transportation to Electro Industries, Inc., and any other materials necessary to perform the exchange, except as stated in this warranty. Replacement material will be invoiced to the distributor in the usual manner and will be subject to adjustment upon verification of defect.
2. Any product or product part that has been damaged as a result of being improperly serviced or operated, including, but not limited to, the following: operated during construction phase, with insufficient water or air flow; allowed to freeze; subjected to flood conditions; subjected to improper voltages or power supplies; operated with air flow or water conditions and/or fuels or additives which cause unusual deposits or corrosion in or on the product; chemical or galvanic erosion; improper maintenance or subject to any other abuse or negligence.
3. Any product or product part that has been damaged as a result of natural disasters, including, but not limited to, lightning, fire, earthquake, hurricanes, tornadoes or floods.
4. Any product or product part that has been damaged as a result of shipment or handling by the freight carrier. It is the receiver's responsibility to claim and process freight damage with the carrier.
5. Any product or product part that has been defaced, abused or suffered unusual wear and tear as determined by Electro Industries, Inc. or its authorized representative.
6. Workmanship of any installer of the product or product part. This warranty does not assume any liability of any nature for unsatisfactory performance caused by improper installation.
7. Transportation charges for any replacement product, product part or component, service calls, normal maintenance; replacement of fuses, filters, refrigerant, etc.

**THESE WARRANTIES DO NOT EXTEND TO ANYONE EXCEPT THE ORIGINAL PURCHASER AT RETAIL AND ONLY WHEN THE PRODUCT IS IN THE ORIGINAL INSTALLATION SITE. THE REMEDIES SET FORTH HEREIN ARE EXCLUSIVE.**

**ALL IMPLIED WARRANTIES, INCLUDING WARRANTIES OF MERCHANTABILITY AND FITNESS FOR A PARTICULAR PURPOSE, ARE HEREBY DISCLAIMED WITH RESPECT TO ALL PURCHASERS OR OWNERS. ELECTRO INDUSTRIES, INC. IS NOT BOUND BY PROMISES MADE BY OTHERS BEYOND THE TERMS OF THESE WARRANTIES. FAILURE TO RETURN THE WARRANTY CARD SHALL HAVE NO EFFECT ON THE DISCLAIMER OF THESE IMPLIED WARRANTIES.**

**ALL EXPRESS WARRANTIES SHALL BE LIMITED TO THE DURATION OF THIS EXPRESS LIMITED WARRANTIES SET FORTH HEREIN AND EXCLUDE ANY LIABILITY FOR CONSEQUENTIAL OR INCIDENTAL DAMAGES RESULTING FROM THE BREACH THEREOF. SOME STATES OR PROVINCES DO NOT ALLOW THE EXCLUSION OR LIMITATION OF INCIDENTAL OR CONSEQUENTIAL DAMAGES, SO THE ABOVE LIMITATIONS OR EXCLUSIONS MAY NOT APPLY. PRODUCTS OR PARTS OF OTHER MANUFACTURERS ATTACHED ARE SPECIFICALLY EXCLUDED FROM THE WARRANTY.**

**THIS WARRANTY GIVES YOU SPECIFIC LEGAL RIGHTS, AND YOU MAY HAVE OTHER RIGHTS WHICH VARY UNDER THE LAWS OF EACH STATE. IF ANY PROVISION OF THIS WARRANTY IS PROHIBITED OR INVALID UNDER APPLICABLE STATE OR PROVINCIAL LAW, THAT PROVISION SHALL BE INEFFECTIVE TO THE EXTENT OF THE PROHIBITION OR INVALIDITY WITHOUT INVALIDATING THE REMAINDER OF THE AFFECTED PROVISION OR THE OTHER PROVISIONS OF THIS WARRANTY.**