



SUBMITTAL DATA

**DBF 4XL
Dryer Exhaust Booster**

Model	Metal Gauge	Avg Wt. (lbs)
DBF 4XL	22	8

STANDARD FEATURES

- Airtight galvanized steel housing
- Permanently lubricated sealed ball bearings
- Self-cleaning backward curved impeller
- Automatic reset thermal overload protection
- 5 1/2 foot 120Vac power cord
- Five-year factory warranty

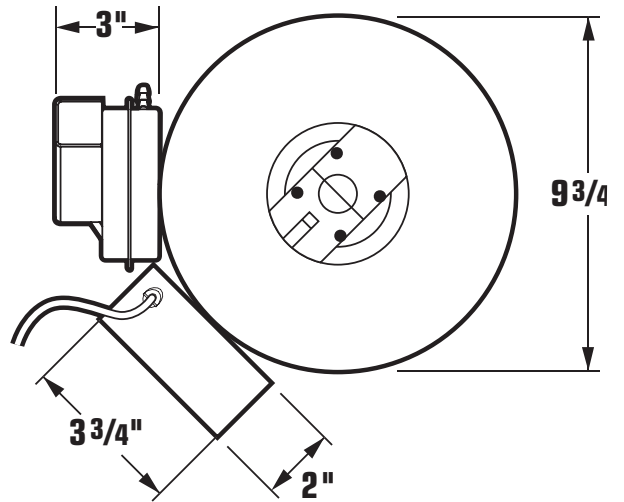
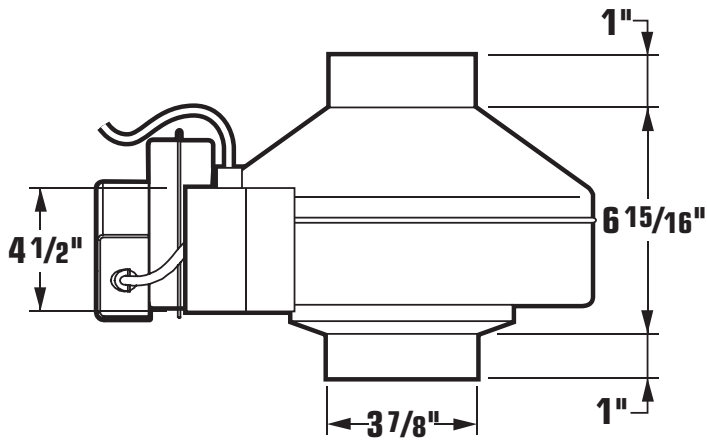

Fan Specifications							Motor Specifications				
Line	Qty	Model No.	Tag	CFM	SP	Fan RPM	Watts	Volts	Phase	Hertz	Encl
1											
2											
3											
4											
5											

Accessory Items	1	2	3	4	5	Accessory Items	1	2	3	4	5
<input type="checkbox"/>						<input type="checkbox"/>					
<input type="checkbox"/>						<input type="checkbox"/>					
<input type="checkbox"/>						<input type="checkbox"/>					
<input type="checkbox"/>						<input type="checkbox"/>					
<input type="checkbox"/>						<input type="checkbox"/>					

Project: _____ Submitted: _____
 Customer: _____ Approved: _____
 Location: _____

