

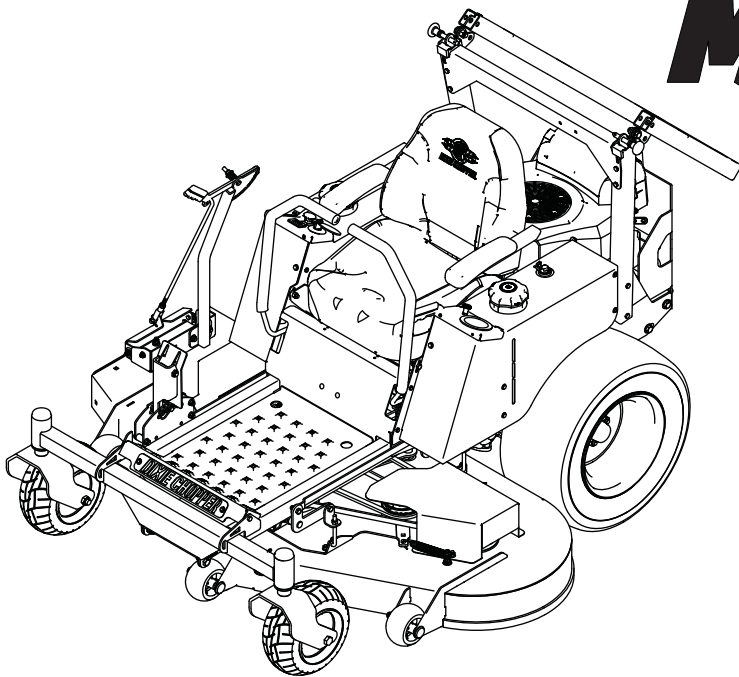

2017 Magnum-HP Safety, Operation & Maintenance Manual



MAGNUM HP

2244KW

2250KW

2750KOE

2460KW

2760KOE

1 CONTENTS

Contents

Introduction

2.1 Important	2
2.2 Product Identification.....	3
2.3 Serial Numbers	3
2.4 Guidelines for the Disposal of Scrap Products.....	4

Safety

3.1 How to Operate Safely	5
---------------------------------	---

Specifications

4.1 Engine Specifications.....	10
4.2 Dimensions and Weights	11
4.3 Mower Specification.....	13
4.4 Cutting Unit Specification	13
4.5 Belt Specification.....	13
4.6 Recommended Lubricants	14
4.7 Accessories.....	14
4.8 Support Literature	15

Decals

5.1 Safety Decals.....	16
5.2 Instruction Decals.....	17

Controls

6.1 Mower Controls.....	19
6.2 Control Panel	20
6.3 Choke Control	22
6.4 Steering Control Levers	22
6.5 Parking Brake.....	22
6.6 Cutting Unit HOC Pedal.....	23
6.7 Operator Controlled Discharge Chute.....	23

Operation

7.1 Daily Inspection.....	24
7.2 Interlock System.....	25
7.3 Operating Procedure.....	26
7.4 Starting The Engine	27
7.5 To Stop The Engine	27
7.6 Driving	28
7.7 Height of Cut	29
7.8 Mowing.....	29
7.9 Mowing On Slopes.....	30
7.10 Towing The Mower.....	32

Maintenance and Lubrication Charts

8.1 Maintenance Chart.....	33
8.2 Fluid Requirements.....	34

Maintenance

9.1 General Precautions	35
9.2 Engine.....	35
9.3 Engine Oil	36
9.4 Engine Air Filter	37
9.5 Engine Exhaust.....	37
9.6 Fuel.....	38
9.7 Charge the battery	38
9.8 Battery.....	39
9.9 Drive Axle Fluid.....	40
9.10 Tires	41
9.11 Wheel Mounting Procedure	41
9.12 Folding ROPS	42
9.13 Air Cooling System	43
9.14 Inspecting Blades.....	43
9.15 Sharpening Blades.....	44
9.16 Electrical System	44
9.17 Belts	45
9.18 Care and Cleaning.....	46
9.19 Mower Storage.....	47

Adjustments

10.1 General Precautions	48
10.2 Forward Speed Limit Screws	48
10.3 Torque Specification	49

Problem Solving

11.1 General	50
--------------------	----

© 2016, Dixie Chopper/Textron Innovations Inc. "All rights reserved, including the right to reproduce this material or portions thereof in any form."

Proposition 65 Warning

This product contains or release chemicals known to the State of California to cause cancer and birth defects or other reproductive harm.

2.1 IMPORTANT

The Dixie Chopper Magnum 2244KW, 2250KW, 2750KOE, 2460KW and 2760KOE with a Gasoline engine is a self propelled rotary mower.

If you follow all instructions in this manual, you increase the life of your mower and keep its maximum performance. Adjustments and maintenance must always be done by an approved technician.

IMPORTANT: Do the maintenance included in this manual to make sure that the quality of cut is kept at a high level.

This **SAFETY, OPERATION AND MAINTENANCE MANUAL** is part of the mower and must stay with the mower always. Suppliers of both original and used mowers need to keep the documentation that comes with the mower.

You must use the mower to cut the grass and not for any other purpose. Compliance with the conditions or operation, service and repair specified by the manufacturer, are understood to be part of the correct use.

ALL operators **MUST** read through this manual and understand the Safety Instructions, controls, lubrication and maintenance procedures.

Make sure that you obey all safety and road traffic regulations.

You must not make any changes to the mower that the manufacturer does not approve. This type of change can release the manufacturer from the liability for any damage or injury.

When you discard worn parts, know the environmental result and use the systems available in the country where the mower is used. When the mower is at its end of life, there are guidelines in this manual for the removal of the mower from use.

Use only Dixie Chopper approved parts.

2006/42/EC

The instructions recorded here are the original instructions confirmed by Dixie Chopper, A Textron Company.

2 INTRODUCTION

2.2 PRODUCT IDENTIFICATION

Mower Serial number plate

A Product code and Serial number



Location of Mower Serial number plate

The serial number plate (A) is found on the right frame tube near the front caster wheel mount.

Engine Identification Number

The engine serial number is found on a label on the side of the engine.

Drive Axle Identification Numbers

The drive axle serial number is found on a plate on the drive axle. There will be a separate serial number for each drive axle.

2.3 SERIAL NUMBERS

Record the mower, engine and drive axle serial numbers below:

Mower Number: _____

Engine Number: _____

Left Drive Axle: _____

Right Drive Axle: _____

2.4 GUIDELINES FOR THE DISPOSAL OF SCRAP PRODUCTS _____

2.4.1 DURING SERVICE LIFE _____

The used oil, oil filters and engine coolant are hazardous materials. Follow the recommended procedures for their safe removal.

If a fluid leaks, contain the spill to make sure that the leak does not flow into the ground or drainage system. Follow the local laws to make sure that leaks are controlled safely.

The maintenance procedures in this manual make sure that the damage that the mower can cause in the local environment is controlled safely.

Take these actions after the mower complete its full service life.

2.4.2 END OF SERVICE LIFE _____

Use these guidelines with applicable Health, Safety and Environmental laws. Always use the approved local waste disposal and agencies for recycled materials.

- Park the mower in a location to use all of the necessary lifting equipment.
- Use the correct tools and Personal Protective Equipment (PPE) and take instruction from the technical manuals applicable to the mower.
- Remove and keep correctly
 1. Batteries
 2. Fuel
 3. Engine coolant
 4. Oils
- Disassemble the structure of the mower and refer to the technical manuals. Give attention to parts that have mechanical pressure or tension applied to the part in the mower, including springs.
- Separate items that continue to have service life and returned to storage.
- Separate items that are worn into the material groups and removed according to the agencies for the recycled materials that are available. Common types are as shown:
 - Steel
 - Non ferrous metals
 - Aluminum
 - Brass
 - Copper
 - Plastic Materials
 - Identified
 - Can be recycled
 - Can not be recycled
 - Not Identified
 - Rubber
 - Electrical and Electronic Components
- Add items that can not be easily separated into different materials to the “General discarded materials” area.
- Do not burn the discarded materials

Change the mower records to show that the mower is not in service and is discarded. Supply this serial number to Dixie Chopper Warranty Department to close their records.

3 SAFETY

3.1 HOW TO OPERATE SAFELY

WARNING

EQUIPMENT OPERATED INCORRECTLY OR WITHOUT TRAINING CAN BE DANGEROUS.

Know the location and correct operation of controls. Operators without experience must receive instruction from another person that knows the correct operation of the equipment before you operate the mower.

Only use parts, accessories and attachments approved by Dixie Chopper.

3.1.1 SAFE OPERATION

- a Read the Operator's Manual and other training material. If the operator or technician can not read this manual, the owner is responsible to describe this material to the operators and technicians.
- a Read all of the instructions for this mower carefully. Know the controls and the correct operation of the equipment.
- b Children or persons who do not understand these instructions must not use the mower. The local regulations can limit the age of the operator.
- c Never use a mower near persons, including children or animals.
- d Remember that the operator or owner is responsible for accidents or hazards that occur to other persons or their property.
- e Never carry passengers.
- f Never allow persons to operate or service the mower or its attachments without correct instructions.
- g Do not operate equipment while tired, sick or after you use alcohol or drugs.

3.1.2 PREPARATION

- a When you operate the mower, wear correct clothing, slip resistant work shoes or boots, work gloves, hard hat, safety glasses and hearing protection. Long hair, loose clothing or jewelry can be caught in moving parts.
- b Do not operate the equipment with the Interlock System disconnected or the system does not operate correctly. Do not disconnect or prevent the operation of any switch.
- c Never operate equipment that is not in correct order or without decals, guards, shields, deflectors or other protective devices fastened.
- d Inspect the mower before you operate the mower. Check the tire pressure, the engine oil level, and the fuel level. Fuel is flammable. Use caution when you add the fuel to the mower.
- e Operate the mower in daylight or in good artificial light. Use caution when you operate the mower during bad weather. Never operate the mower with lightning in the area.
- f Inspect the area to select the accessories and attachments that are needed to correctly and safely do the job. Only use parts, accessories and attachments approved by Dixie Chopper.
- g Be careful of holes in the terrain and other hazards that are not visible.
- h Inspect the area where the equipment is operated. Remove all objects you can find before you operate. Be careful of obstructions above the ground (low tree limbs, electrical wires) and also underground obstacles (sprinklers, pipes, tree roots). Enter a new area carefully. Look for possible hazards.
- i Inspect the cutting system before you start the mower. Make sure the blades are free to rotate. When you rotate one blade, other blades can rotate.

3.1.3 OPERATION

- a Never operate the engine without enough ventilation or in an enclosed area. The carbon monoxide in the exhaust fumes can increase to dangerous levels.
- b Never carry passengers. Keep other persons or animals away from the mower.
- c Disengage all drives and engage the parking brake before you start the engine. Only start the engine with the operator in the seat. Never start the engine with persons near the mower.
- d Keep your legs, arms and body inside the operator compartment while the mower is in operation. Keep your hands and feet away from the cutting units.
- e Do not use on the slopes greater than the safe slope limit for the equipment.
- f To guard against over turning or loss of control:
 - Operate the mower up and down on the face of slopes (vertically), but not across the face (horizontally).
 - Do not start or stop suddenly on slopes.
 - Decrease the speed when you operate on slopes or when you must turn. Use caution when you change direction. Turf condition can change the mower stability.
 - Use caution when you operate the mower near drop-offs, ditches or embankments.
 - Be careful of holes in the terrain and other hazards that are not visible.
- g When you drive in the reverse direction, look behind you and down to make sure the path is clear. Do not operate the cutting unit when you drive in the reverse direction.
- h Use caution when you go near corners, trees or other objects that can prevent a clear view.
- i Equipment must meet the current regulations to be driven on the public roads.
- j Before you move across or operate on the paths or roads, turn off the PTO switch, lift the cutting unit and travel at decreased speed. Look for traffic.
- k Stop the blades when the mower is on any surface that is not grass.
- l Do not release the cut grass in the direction of persons or allow persons near the mower while in operation.
- m Do not operate the mower with damaged guards or without safety devices in position.
- n Do not change the engine governor setting or over-speed the engine. Never change or tamper with adjusters that are closed with a seal for the engine speed control.
- o Before you leave the operator compartment, for any reason:
 - Disengage all the drives and lower the cutting unit to the ground.
 - Engage the parking brake.
 - Stop the engine and remove the key.
- p When you hit an object or mower starts to cause the vibration that is not normal, inspect the mower for damage and make repairs.
- q Decrease the throttle setting before you stop the engine.
- r Do not use this equipment for uses that the mower was not made for.

3 SAFETY

3.1.4 ROPS

- a The ROPS is a safety device. Keep the ROPS in the vertical and locked position. Always use the seat belt when you operate the mower. Make sure the seat belt can be released quickly in an emergency.
- b Only operate the mower with the ROPS in the folded position on flat and level surfaces when necessary. Do not operate the mower with the ROPS in the folded position on slopes, near sharp edges or near water. There is no roll over protection with the ROPS in the folded position.
- c Check for clearance before you drive below objects. Do not contact tree branches, electrical wires or other objects with the ROPS.
- d Do not use the seat belt with the ROPS in the folded position.
- e Inspect the ROPS for damage. Keep the ROPS hardware fastened.
- f Do not weld, drill, change or bend the ROPS. Replace a damaged ROPS. Do not try to correct a damaged ROPS.
- g Do not remove the ROPS from the mower.
- h Dixie Chopper must approve any changes to the ROPS.

3.1.5 SAFE HANDLING OF FUELS

- a The fuel and the fuel vapors are flammable. Use caution when you add the fuel to the mower. The fuel vapors can cause an explosion.
- b Never use the containers that are not approved to keep or transfer fuel.
- c Never keep the mower or fuel containers near an open flame or any device that can cause the ignition of fuel or fuel vapors.
- d Never fill the fuel containers inside a vehicle or on a truck or trailer with a plastic liner. Always put the fuel container on the ground away from your vehicle before you fill the container.
- e Refuel the mower before you start the engine. When the engine is in operation or while the engine is hot, never remove the fuel cap or add fuel to the mower.
- f Refuel outdoors only and do not smoke when you add fuel. Extinguish all types of ignition.
- g The fuel nozzle must touch the rim of the fuel tank when you add fuel to the mower. Do not use a device to lock the fuel nozzle in the open position.
- h Do not over fill the fuel tank. Leave at least 1 inch (2.5 cm) below the filler neck.
- i Always tighten the fuel tank cap and container cap after you add fuel.
- j If the fuel spills on your clothing, change your clothing immediately.

3.1.6 MAINTENANCE AND STORAGE

- a Before you clean, adjust or repair this equipment, push PTO switch to the OFF position, lower the cutting unit to the ground, engage the parking brake, stop the engine and remove the key.
- b Make sure the mower is parked on a solid and level surface.
- c Never work on a mower that is lifted only by the jack. Always use the jack stands.
- d Never allow persons to service the mower or its attachments without correct instructions.
- e When the mower is parked, put into storage or left without an operator, lower the cutting device unless a positive mechanical lock is used.
- f When you put the mower on a trailer or put the mower in storage, close the fuel valve. Do not keep fuel near flames or drain the fuel inside a building.

- g Disconnect the battery before you service the mower. Always disconnect the negative battery cable before the positive battery cable. Always connect the positive battery cable before the negative battery cable.
- h Charge the battery in an area with good airflow. The battery can release hydrogen gas that is explosive. To prevent an explosion, keep any device that can cause sparks or flames away from the battery.
- i Disconnect the battery charger from the power supply before you connect or disconnect the battery charger to the battery. Wear protective clothing and use insulated tools when you service the battery.
- j Be careful and wear gloves when you check or service the cutting unit blades. Replace any damaged blades, do not try to correct a damaged blade.
- k Keep your hands and feet away from parts that move. Do not adjust the mower with the engine in operation, unless the adjustment needs the engine in operation.
- l Carefully release the pressure from components with stored energy.
- m To prevent injury from the hot, high pressure oil, never use your hands to check for oil leaks. Use the paper or cardboard to find leaks.
- n The hydraulic fluid pressure can have enough force to enter your skin. If hydraulic fluid has entered your skin, a doctor must remove the hydraulic fluid surgically within a few hours or gangrene can occur.
- o When you service the hydraulic system, make sure the hydraulic fittings, tubes and hoses are tightened to the correct torque. Make sure the hydraulic system is in good condition before you start the engine.
- p Keep the mower and the engine clean.
- q Allow the engine to become cool before storage and always remove the ignition key.
- r Keep all nuts, bolts and screws tight to make sure the equipment is in safe condition.
- s Replace worn or damaged parts for safety. Replace damaged or worn decals. Only use parts, accessories and attachments approved by Dixie Chopper.
- t To decrease the fire hazard, remove materials that burn from the engine, muffler, battery tray and fuel tank area.
- u Disconnect the battery and controller connectors before you weld on this mower.

3.1.7 WHEN YOU PUT THE MOWER ON A TRAILER

- a Be careful when you load or unload the mower on a trailer. Trailer must be wider than the mower and can carry the weight of the mower.
- b Use a full-width ramp to load or unload the mower on a trailer.
- c Use straps, chains, cables or ropes to fasten the mower to the trailer. Both front and rear straps must be sent down and toward sides of trailer.
- d Make sure that all latches are correctly fastened.

3 SAFETY

3.1.8 IMPORTANT SAFETY NOTES



This safety alert symbol gives a warning of possible hazards.

DANGER - Indicates a dangerous condition that WILL cause death or injury unless it is prevented.

WARNING - Indicates a dangerous condition that CAN cause death or injury unless it is prevented.

CAUTION - Indicates a dangerous condition that can cause injury and property damage unless it is prevented. The label can indicate work procedures that are not safe.

NOTICE - Indicates a condition that can cause damage to the property unless it is prevented. The label can indicate work procedures that are not safe.

Some illustrations in this manual show the shields, guards or plates, removed. Do not operate this equipment without these devices correctly fastened in position.



WARNING

The Interlock System on this mower prevents the operation of the mower unless a.) The parking brake is engaged. b.) The PTO switch is in the OFF position and c.) The steering control levers are in the Neutral position. The system will stop the engine if the operator leaves the operator position without:

- a.) The parking brake engaged
- b.) The steering control levers in the Neutral position and
- b.) the PTO switch in the OFF position.

NEVER operate the mower unless the Interlock System operates correctly.



WARNING

1. Before you leave the operator position, for any reason:
 - a. Return the steering control levers to Neutral.
 - b. Disengage all drives.
 - c. Lower the cutting unit to the ground.
 - d. Engage the parking brake.
 - e. Stop the engine and remove the ignition key.
2. Keep your hands, feet and clothing away from moving parts. Wait for all movement to stop before you clean, adjust or service the mower.
3. Keep persons and animals away from the area of operation.
4. Never carry passengers.
5. Never operate the equipment without a correctly fastened grass deflector in position.

If additional information or service is needed, contact your Authorized Dixie Chopper Dealer. Your Dealer knows the current methods to service this equipment.

4.1 ENGINE SPECIFICATIONS

Magnum	2244KW / 2250KW	2460KW	2750KOE/2760KOE
Make	Kawasaki	Kawasaki	Kohler
Model	FX651V	FX730V	EZT750
Type	Four cycle, air cooled, V-Twin, OHV	Four cycle, air cooled, V-Twin, OHV	Four cycle, air cooled, V-Twin, OHV
Number of Cylinders	2	2	2
Bore and Stroke	3.07 x 2.99 in. (7.8 x 7.6 cm)	3.07 x 2.99 in. (7.8 x 7.6 cm)	3.27 x 2.7 in. (8.3 x 6.9 cm)
Total Displacement	44.3 in ³ (0.726 l)	44.3 in ³ (0.726 l)	45.6 in ³ (0.747 l)
Intake System	Naturally Aspirated	Naturally Aspirated	Naturally Aspirated
Gross Intermittent Power	22.0 hp (16.4 kW) @ 3600 RPM	23.5 hp (16.8 kW) @ 3600 RPM	27 hp (20.1 kW) @ 3600 RPM
Compression Ratio	8.2:1	8.2:1	9.0:1
Maximum Speed	3600 ± 100 rpm (No Load)	3600 ± 100 rpm (No Load)	3600 ± 100 rpm (No Load)
Low Idle	1550 ± 100 rpm (No Load)	1550 ± 100 rpm (No Load)	1750 ± 100 rpm (No Load)
Rotation	Clockwise viewed at flywheel	Clockwise viewed at flywheel	Clockwise viewed at flywheel
Fuel System	Dual Barrel Float Feed Carburetor	Dual Barrel Float Feed Carburetor	Closed Loop Electronic Fuel Injection (EFI)
Fuel	87 Octane Gasoline Maximum 10% Ethanol	87 Octane Gasoline Maximum 10% Ethanol	87 Octane Gasoline Maximum 10% Ethanol
Ignition System	Two magnetos triggered by flywheel magnets	Two magnetos triggered by flywheel magnets	Two magnetos triggered by flywheel magnets
Spark Plug	NGK BPR4ES	NGK BPR4ES	
Spark Plug Gap	0.030 Inch (0.76 mm)	0.030 Inch (0.76 mm)	0.030 Inch (0.76 mm)
Engine Oil (API Class)	SF, SG, SH, SJ or SL	SF, SG, SH, SJ or SL	SJ or higher
Oil Pan Capacity	2.3 quarts (2.2 l)	2.3 quarts (2.2 l)	2.0 quarts (1.9 l)
Starter	12 Volt Electric Starter	12 Volt Electric Starter	12 Volt Electric Solenoid Shift Starter
Alternator	12 Volt, 15 Amp	12 Volt, 15 Amp	12 Volt, 15 Amp
Dry Weight	101 lb. (45.8 kg)	101 lb. (45.8 kg)	91 lb. (41.3 kg)
Dimensions (Length x Width x Height)	18.9 x 18.2 x 22.2 in. (47.9 x 46.2 x 56.5 cm)	18.9 x 18.2 x 22.2 in. (47.9 x 46.2 x 56.5 cm)	18.8 x 18.9 x 17 in. (47.8 x 48 x 43.2 cm)
Emission Regulation			

4 SPECIFICATIONS

4.2 DIMENSIONS AND WEIGHTS

	2244KW	2250KW / 2750KOE	2460KW / 2760KOE
A - Width of Cut	44 inch (111.8 cm)	50 inch (127 cm)	60 inch (152.4 cm)
B - Maximum Width	49 inch (124.5 cm)	55 inch (139.7 cm)	65 inch (165.1 cm)
C - Height (ROPS Folded)	49 inch (124.5 cm)		
D - Height (ROPS Up)	74 inch (188 cm)		
E - Total length (ROPS Folded)	87 inch (221cm)		
F - Total length (ROPS Up)	80 inch (203.2 cm)		
G - Wheel Base	46.6 inch (118.4 cm)		
H - Front Wheel Track	32.1 inch (81.5 cm)	32.1 inch (81.5 cm)	38.9 inch (98.8 cm)
J - Rear Wheel Track	35.6 inch (90.4 cm)		
Weight of unit	824 lb. (373.8 kg)	844 lb. (382.8 kg)	924 lb. (419.1 kg)

Tire Specifications					
Front Wheel			Rear Wheel		
Tire Size	Type	Tire Pressure	Tire Size	Type	Tire Pressure
13 x 6.5-6		N/A	23 x 10.5-12	Grass Master	8-10 psi (0.55-0.69 BAR)

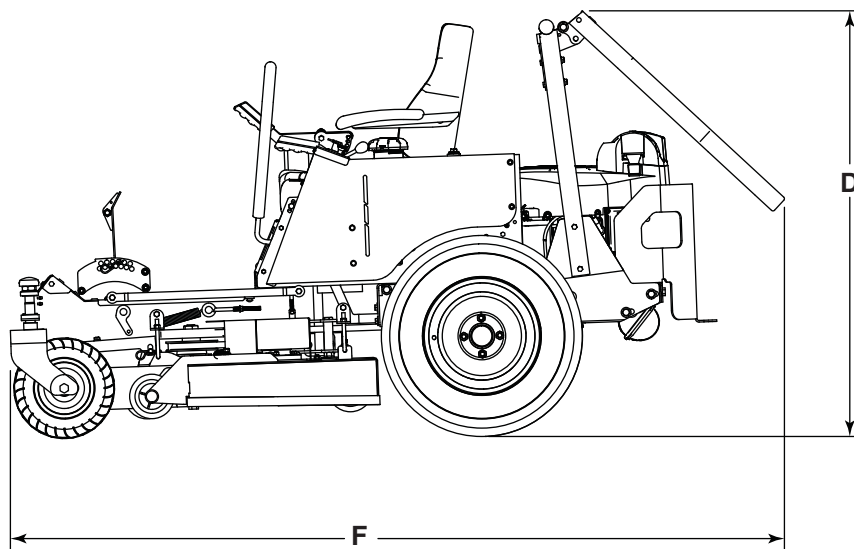
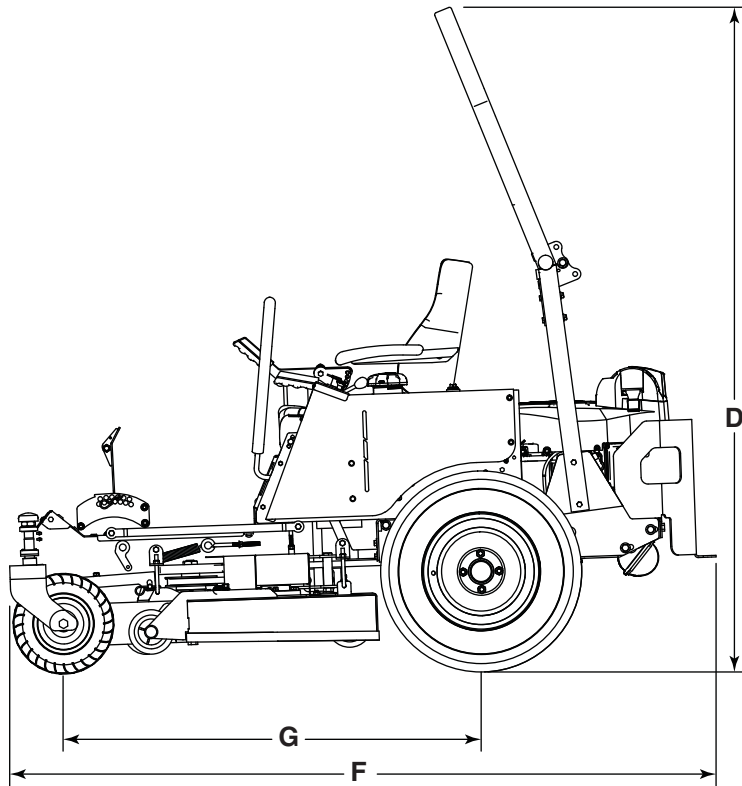
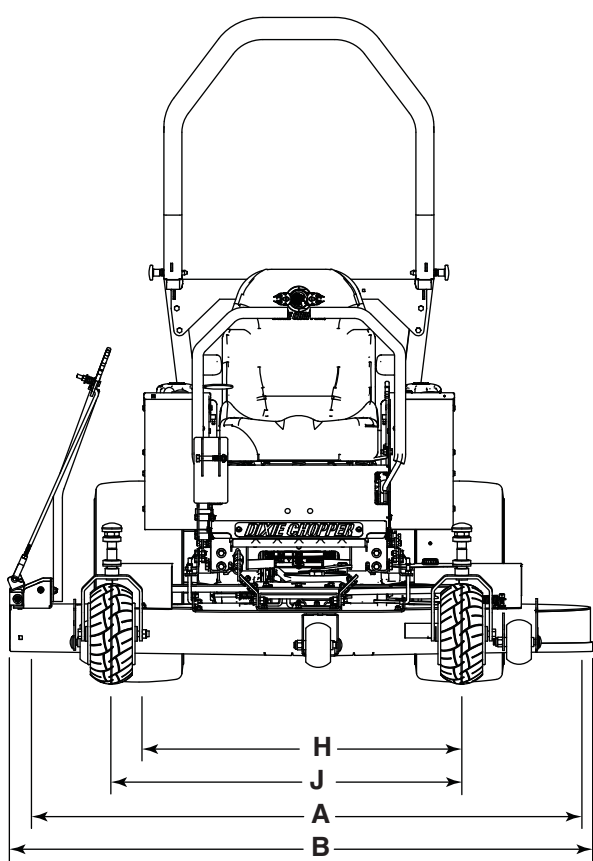

4 SPECIFICATIONS

4.3 MOWER SPECIFICATION

Battery:	12V, 300 CCA
Service Brake:	Dynamic braking through the traction circuit
Parking Brake:	Hand lever connected to brake in both drive axles
Fuel Tank:	8 U.S. Gallons (30.3 l)
Steering:	Hand lever speed and direction controls for left and right rear wheel
Traction Drive:	Belt driven dual hydrostatic Hydro-Gear ZT-3400 drive axle
Cutting Unit Drive:	Belt drive with electric clutch
Ground Speed:	0-8 mph (0-12.9 kph)
44 in. Deck Cutting Performance:	Up to 2.8 acres/hr. (1.26 hectares/hr) @7 mph (11.27 km/hr)
50 in. Deck Cutting Performance:	Up to 3.2 acres/hr. (1.29 hectares/hr) @7 mph (11.27 km/hr)
60 in. Deck Cutting Performance:	Up to 3.8 acres/hr. (1.55 hectares/hr) @7 mph (11.27 km/hr)

4.4 CUTTING UNIT SPECIFICATION

	2244KW	2250KW / 2750KOE	2460KW / 2760KOE
Blade Length	17 inch (43.2 cm)	17-7/8 inch (45.4 cm)	21-3/8 inch (55.6 cm)
Number of blades	3		
Height of cut	1-1/2 to 4-1/2 in. (3.8 to 11.4 cm) in 1/4 in. (6.35 cm) increments		
Height of cut adjustment	A foot lever to lift or lower the cutting unit with a HOC pin installed in different holes for specified HOC.		
Blade Tip Speed @ 3600 rpm engine speed	298.1 feet/second (90.9 meters/second)	274.0 feet/second (83.5 meters/second)	267.0 feet/second (81.4 meters/second)

4.5 BELT SPECIFICATION

Traction Belt	Part Number 2006A62R , A-Section, Raw, 62 in. EL Belt
Engine to 44/60 Inch Deck Belt	Part Number 2010B100W , B-Section, Wrapped, 100 in. EL Belt
Engine to 50 Inch Deck Belt	Part Number 2010B97W , B-Section, Wrapped, 97 in. EL Belt
44 in. Deck Belt	Part Number 2008B101R , B-Section, Raw, 101 in. EL Belt
50 in. Deck Belt	Part Number 2006B112R , B-Section, Raw, 112 in. EL Belt
60 in. Deck Belt	Part Number 2006B128R , B-Section, Raw, 128 in. EL Belt

4.6 RECOMMENDED LUBRICANTS

Engine Oil:

Kawasaki Engine: API Classification grades SF, SG, SH, SJ or SL

Temperature	Viscosity
Above 95° F (35° C)	SAE 40
68° to 95° F (20° to 35° C)	SAE 30 or SAE 10W-30 or SAE 10W-40 or SAE 40
32° to 68° F (0° to 20° C)	SAE 30 or SAE 10W-30 or SAE 10W-40
-4° to 32° F (-20° to 0° C)	SAE 5W-20 or SAE 10W-30 or SAE 10W-20
Below -4° F (-20° C)	SAE 5W-20

Kohler Engine: API Classification grades SJ or higher

Temperature	Viscosity
Above 50° F (10° C)	SAE 30 or SAE 10W-30
32° to 50° (0° to 10° C)	SAE 10W-30
0° to 32° F (-18° to 0° C)	SAE 5W-30 or SAE 10W-30
Below 0° F (-18° C)	SAE 5W-30

Drive Axle Fluid:

The standard drive axle fluid is SAE 20W50 API Classification SL.

Grease:

Texaco Starplex 2EP Moly (NLGI Grade 2-EP Lithium Complex Grease containing Molybdenum Disulfide) or equivalent.

4.7 ACCESSORIES

4.7.1 STRIPING KIT

Kit Number 902808

4.7.2 ROLL BAR WITH HARDWARE KIT

44 inch deck Kit Number 902763

50/60 inch deck Kit Number 902764

4.7.3 COMPLETE ROPS KIT

44 inch deck Kit Number 902661

50/60 inch deck Kit Number 902665

4.7.4 SEAT BELT KIT

Kit Number 902136

4.7.5 ROLL BAR HARDWARE KIT

Kit Number 900412

4.7.6 LIGHT ACCESSORY KIT

Kit Number 900366

4 SPECIFICATIONS

4.7.7 REPLACEMENT BLADES

Standard 17 inch (43.2 cm) X-Blade Part Number 30227-50X (For 44 inch (111.8 cm) cutting unit)
Optional 17 inch (43.2 cm) Twist Blade Part Number 30227-50T (For 44 inch (111.8 cm) cutting unit)
Optional 17 inch (43.2 cm) Eliminator Blade Part Number 30227-50E (For 44 inch (111.8 cm) cutting unit)
Standard 17-7/8 inch (45.4 cm) X-Blade Part Number 30227-52X (For 50 inch (127 cm) cutting unit)
Optional 17-7/8 inch (45.4 cm) Twist Blade Part Number 30227-52XT (For 50 inch (127 cm) cutting unit)
Optional 17-7/8 inch (45.4 cm) Eliminator Blade Part Number 30227-52E (For 50 inch (127 cm) cutting unit)
Standard 21-3/8 inch (55.6 cm) X-Blade Part Number 30227-62X (For 60 inch (152.4 cm) cutting unit)
Optional 21-3/8 inch (55.6 cm) Twist Blade Part Number 30227-62T (For 60 inch (152.4 cm) cutting unit)
Optional 21-3/8 inch (55.6 cm) Eliminator Blade Part Number 30227-62E (For 60 inch (152.4 cm) cutting unit)

4.7.8 COMPLETE DECK ASSEMBLY

44 inch (111.8 cm) Kit Number 300520
50 inch (127 cm) Kit Number 300521
60 inch (152.4 cm) Kit Number 300522

4.7.9 MULCHER KIT

44 inch (111.8 cm) Kit Number 903013
50 inch (127 cm) Kit Number 903014
60 inch (152.4 cm) Kit Number 903015

4.7.10 OCDC KIT

44 inch (111.8 cm) Kit Number 300498
44 inch (111.8 cm) OCDC Riser Kit Number 300532
44 inch (111.8 cm) OCDC Base Kit Number 300533
50 inch (127 cm) Kit Number 300499
60 inch (152.4 cm) Kit Number 300500

4.7.11 MICHIGAN SUSPENSION SEAT KIT

Kit Number 400321

4.7.12 OPTIONAL WHEELS

13 x 6.50-6 Rib Complete Front Wheel Number 401953
13 x 6.5-6 Motorcycle Pneumatic Complete Front Wheel Number DUP-400438
LH 24 x 7-10 Turf Boss V Complete Rear Wheel Number 400261
RH 24 x 7-10 Turf Boss V Complete Rear Wheel Number 400262

4.7.13 STEERING ARM KIT

LH Clear Zinc Steering Arm Kit Number 902905
RH Clear Zinc Steering Arm Kit Number 902906

4.7.14 MAGNUM FAN SHIM KIT

Kit Number 901910

4.7.15 MAGNUM PTO KIT

44 inch deck Kit Number 38120901
50/60 inch deck Kit Number 38120901

4.8 SUPPORT LITERATURE

Contact your Dixie Chopper Dealer for a complete listing of literature available for your mower.
Operator's Manual: 700565
Mower Parts Manual: 700584

5.1 SAFETY DECALS

Understand the purpose of these decals. The decals are important to the safe operation of the mower. REPLACE THE DAMAGED DECALS IMMEDIATELY.



Serious injury or death can result from blade contact or from contacting the belts or pulleys with the engine running. Deck spindles may have a fan installed above or below the pulleys.

Do not operate the mower with the discharge chute or belt guards removed. Make sure the Interlock System is operates correctly.

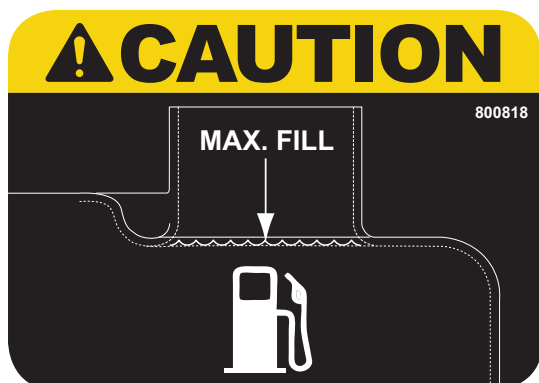
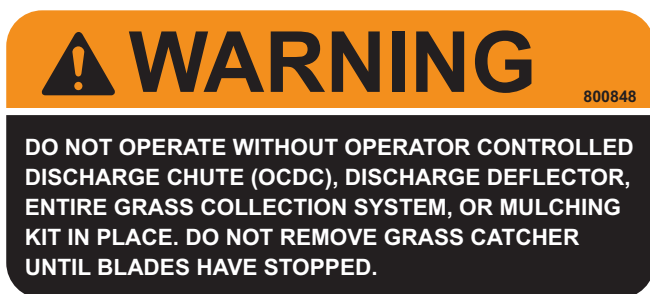

Only fill the fuel tank to the bottom of the fuel filler neck. Do not overfill the fuel tank.

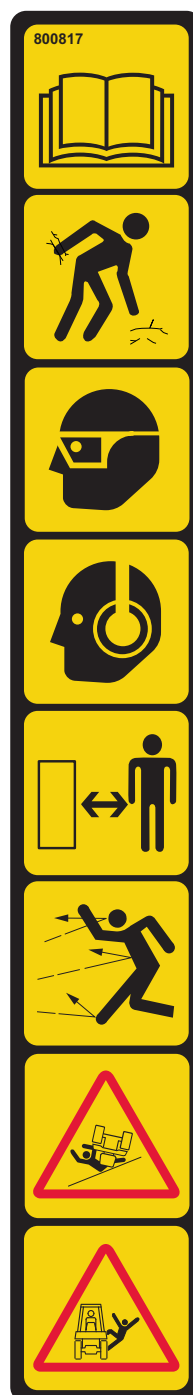

Read the manual before you operate the mower

Pick up sticks, stones and other debris that can be thrown by the mower.

Wear eye protection when you operate the mower.

Wear ear protection when you operate the mower.

Keep bystanders away from the mower.

Be careful of debris thrown by the mower.

Use caution when you operate on slopes. Only operate on slopes with the ROPS in the vertical position.

Do not carry passengers.

5 DECALS

CAUTION

800192

**WHEN ADDING OIL FOR TRANSAXLES,
USE MULTIVISCOSITY SAE 20W-50 OIL**

**DO NOT ADD AUTOMATIC TRANSMISSION FLUID
OR HYDRAULIC FLUID!
THIS WILL VOID WARRANTY**

**CHECK OIL WHEN COLD. MAINTAIN OIL LEVEL TO THE COLD FILL
LINE ON THE DRIVE OIL EXPANSION TANK (APPROXIMATELY 1/4"
FROM BOTTOM) DO NOT TOP OFF DRIVE OIL EXPANSION TANK!**

Transaxle service interval: Initial 75 hrs., every 400 hrs thereafter

**OIL/FILTER CHANGE TO BE PERFORMED
BY AUTHORIZED DIXIE CHOPPER SERVICE DEALER ONLY!**

5.2 INSTRUCTION DECALS

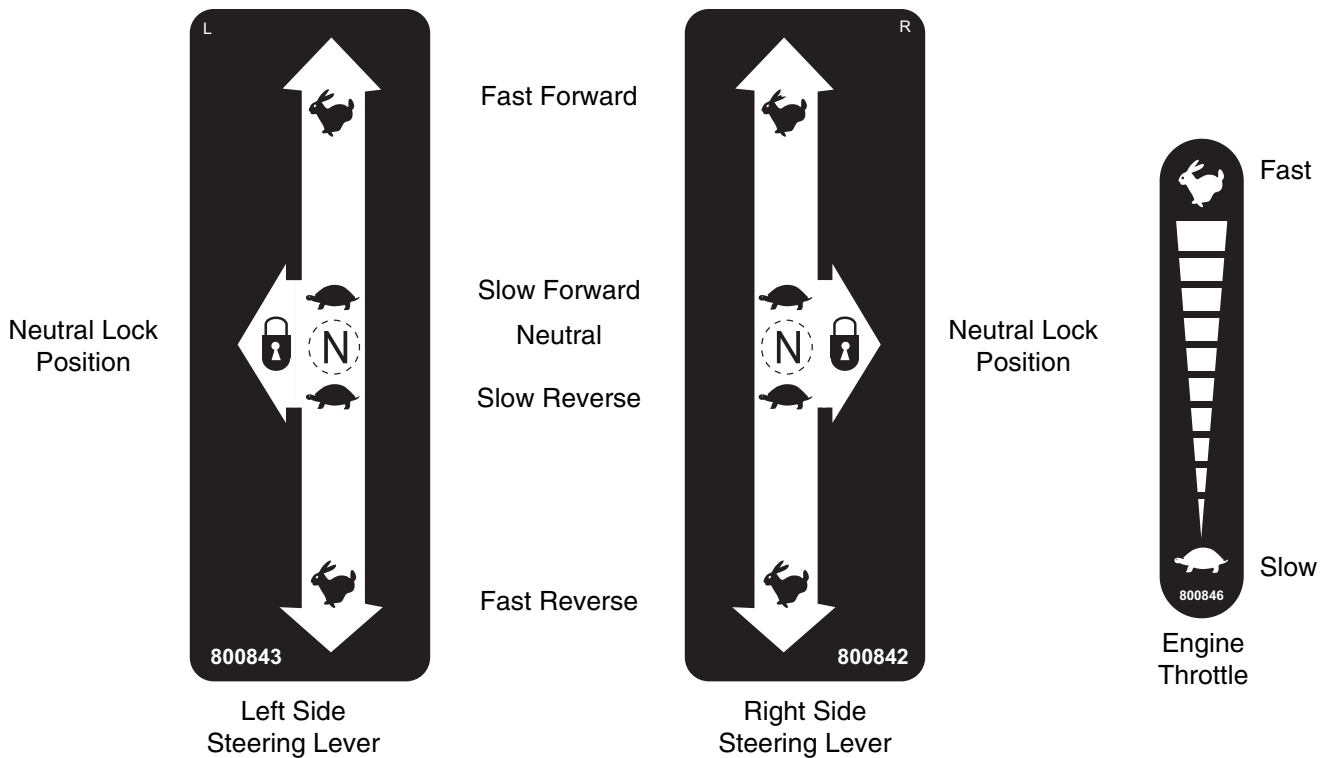

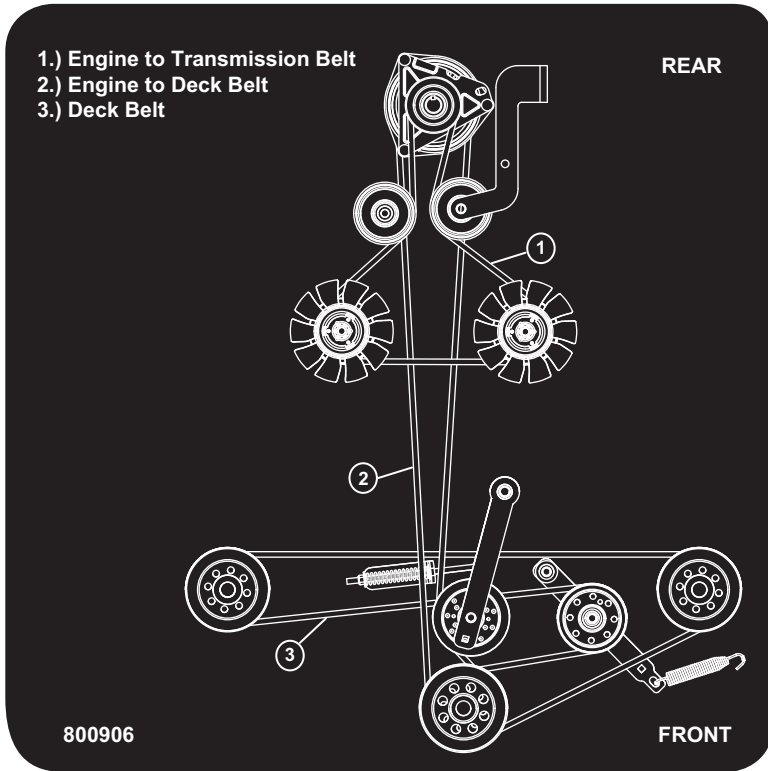

Disengaged
Position



Engaged
Position

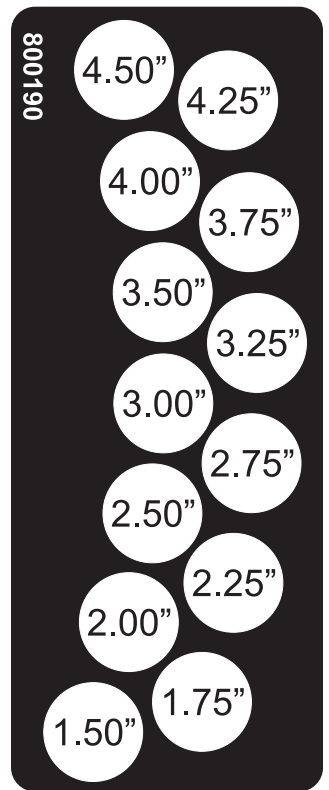

Height of Cut



No Step



6 CONTROLS

6.1 MOWER CONTROLS

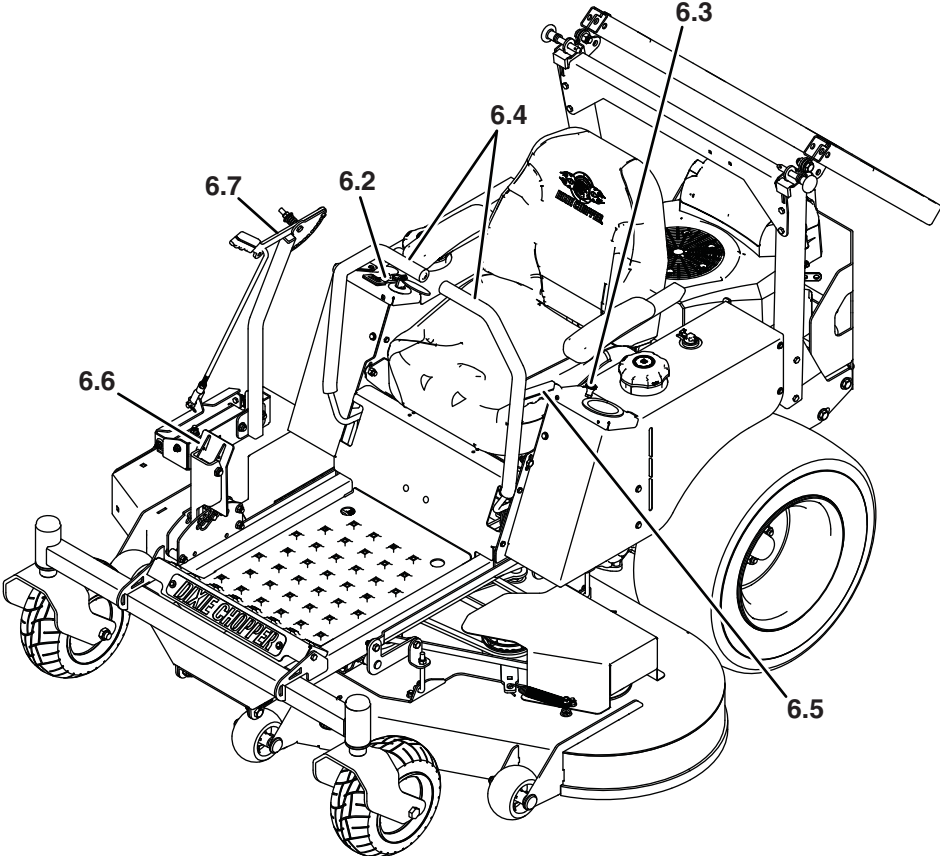

6.2 CONTROL PANEL

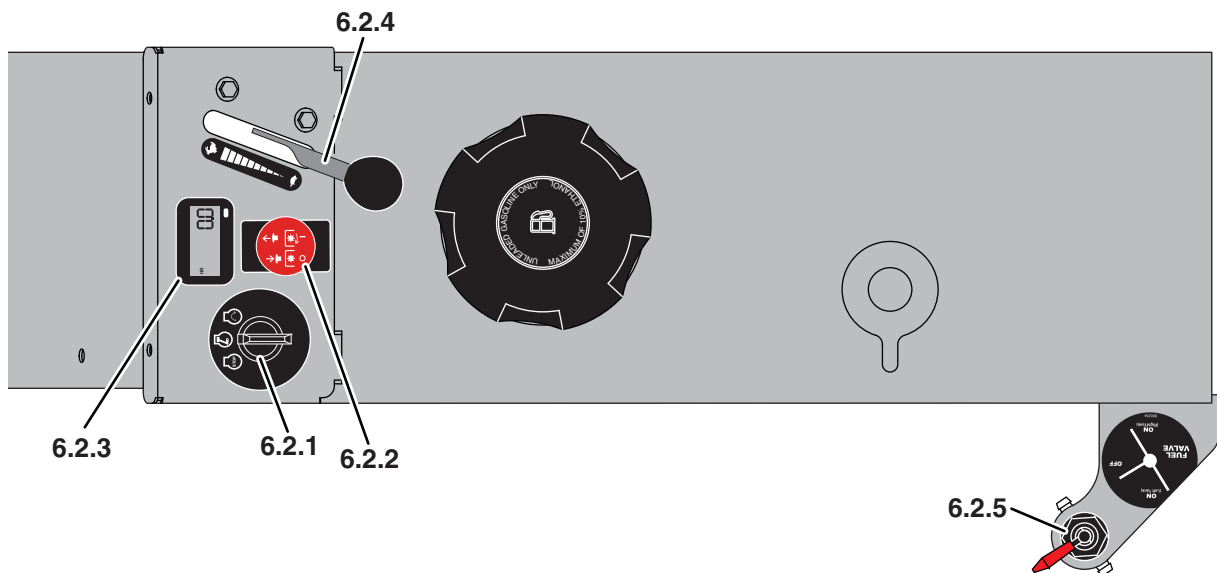

6.2.1 IGNITION SWITCH

The ignition switch has three positions, OFF, RUN and START.

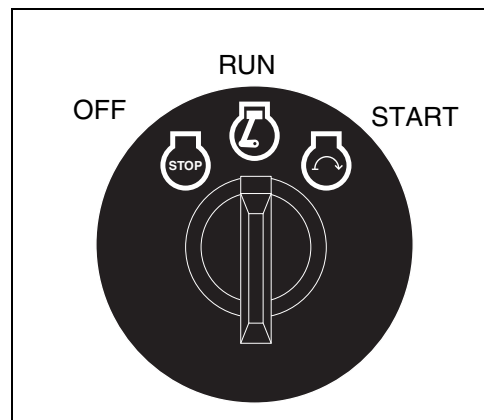

6.2.2 PTO SWITCH

The PTO switch is a 2-position knob type switch to engage and to disengage the cutting unit. The PTO switch must be in the OFF (down) position to start the engine.

Pull on the red knob to move the switch to the ON position. When the PTO switch is in the ON position, the cutting unit is engaged.

Always mow with the throttle lever in the fast position.

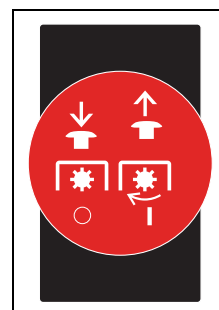

6 CONTROLS

6.2.3 HOUR METER

The hour meter shows the hours of operation and engine speed.

Press and release the mode button to toggle between functions.

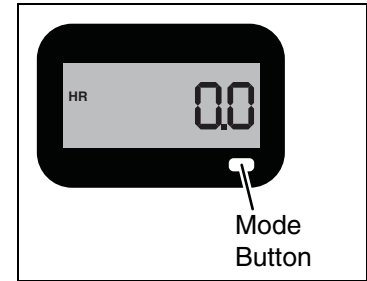

6.2.4 THROTTLE LEVER

The throttle lever controls the engine speed. Always operate the mower at full throttle during normal operation.

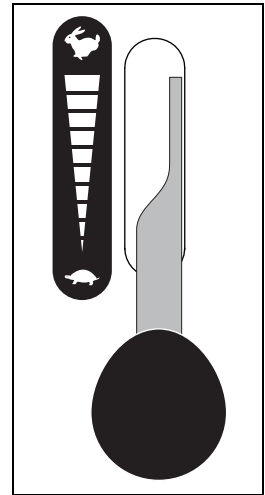

6.2.5 FUEL SELECT VALVE

The fuel select valve allows the operator to determine which tank the engine takes fuel from. The valve can also stop fuel flow to the engine.

To use the left fuel tank, rotate the valve handle so it points toward the left tank position.

To use the right fuel tank, rotate the valve handle so it points toward the right tank position.

To stop the fuel flow, rotate the handle so it points toward the OFF position. Keep the fuel valve in the OFF position when the mower is not being used.

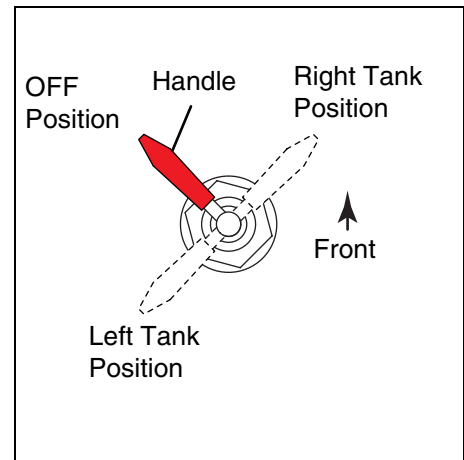

6.3 CHOKE CONTROL

Used with Kawasaki engines only. When you start a cold engine, pull the choke control to the choke position. Slowly push the choke lever to the RUN position when the engine becomes warm.

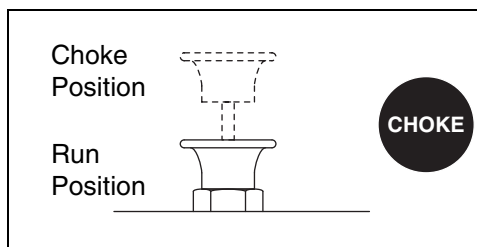

NOTICE

The choke control is not necessary to start a warm engine.

6.4 STEERING CONTROL LEVERS

The mower has separate drive axles for each rear wheel. The right-side control lever controls the operation of the right-side drive axle. The left-side control lever controls the operation of the left-side drive axle. See 7.6 for the operation of the steering control levers.

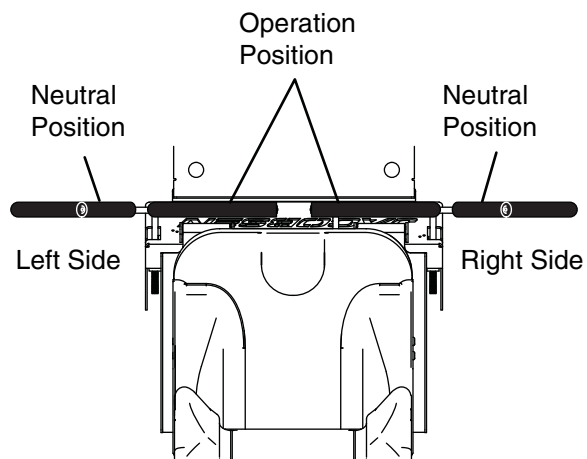

DANGER

To prevent personal injury or death, do not quickly move the steering control levers or suddenly start and stop the mower. You must use more caution when you turn the mower or when you operate on slopes.

To put the steering control levers in the Neutral position, move the steering control levers toward the left and right sides.

The steering control levers must be in the Neutral position, the PTO switch must be in the OFF (down) position and the parking brake engaged to start the mower.

6.5 PARKING BRAKE

The parking brake lever engages the drive axle brakes to prevent movement of the mower. The parking brake should be engaged when the mower is stationary and/or unoccupied.

When the steering control levers are in the Neutral position, pull the parking brake lever back to the engaged position to engage the parking brake. Push the parking brake lever forward to the disengaged position to disengage the parking brake.

The steering control levers must be in the Neutral position, the PTO switch must be in the OFF (down) position and the parking brake engaged to start the mower.

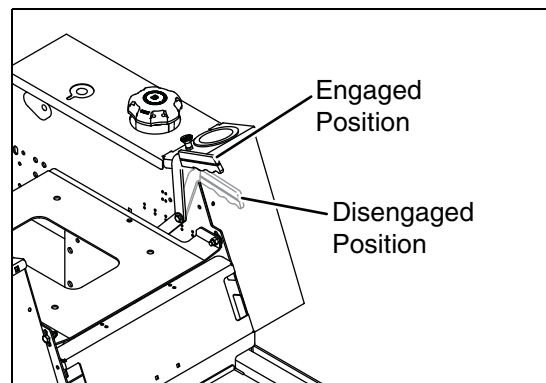

6 CONTROLS

6.6 CUTTING UNIT HOC PEDAL

The cutting unit height of cut (HOC) pedal lifts and lowers the cutting unit.

Install the HOC pin in the correct position for the cutting height. To lower the cutting unit, press forward on the top part of the pedal and slowly allow the pedal to lift until the lift pedal touches the HOC pin.

See 7.7 for the HOC pin position chart.

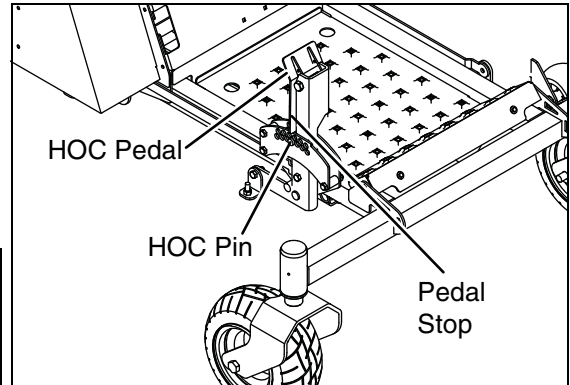

NOTICE

To prevent damage to the HOC mechanism or the cutting unit, slowly allow the pedal to lift until the lift pedal touches the HOC pin. Do not allow the cutting unit to drop from the lifted position against the HOC pin.

To lift the cutting unit, fully push on the bottom of the HOC pedal. The the pedal stop will contact the HOC bracket and hold the cutting unit in the raised position. Release the HOC pedal.

6.7 OPERATOR CONTROLLED DISCHARGE CHUTE

The operator controlled discharge chute (OCDC) lever opens and closes the discharge chute. When you mow around flower beds or edges of paths, the discharge chute can be closed to limit the discharge. Never mow with the discharge deflector removed.



WARNING

The operator must be careful of persons and objects near the mower. Do not release the cut grass in the direction of persons or allow persons near the mower while in operation.

Never operate the mover with the discharge chute removed. The cutting unit can discharge objects for long distances with the discharge chute removed. Remember that the operator and/or owner are responsible for accidents or hazards that occur to other persons or their property.

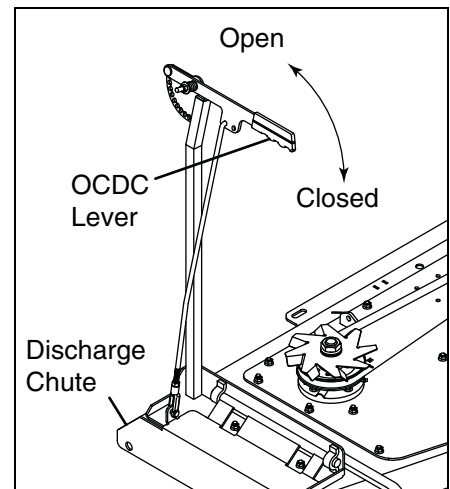

7.1 DAILY INSPECTION

**CAUTION**

The inspection must be done each day when the engine is turned off and all fluids are cold. Lower the cutting units to the ground, engage the parking brake, stop the engine and remove the ignition key.

Do a visual inspection of the mower. Look for indications of wear or loose hardware. Look for any components that are not included on the mower or damaged components. Check for fuel and oil leaks to make sure the connections are tight. Make sure that all hoses are in good condition.

Check the fuel supply and crankcase oil level. When the engine is cold, all fluids must be at the full level mark.

Check all tires for the correct pressure.

Test the Interlock system.

7 OPERATION

7.2 INTERLOCK SYSTEM

The Interlock System prevents the engine to start unless the steering control levers are in the Neutral position, the parking brake is engaged and the PTO switch is in the OFF (Down) position. The system stops the engine if the operator leaves the seat with the PTO switch in the ON position, steering control levers out of the NEUTRAL position or the parking brake disengaged.



WARNING

Do not operate the equipment with the Interlock System disconnected or the system does not operate correctly. Do not disconnect or prevent the operation of any switch.

Do each of these tests to make sure the Interlock System operates correctly. If any of the tests fail, stop the test and have the system inspected and repaired as shown below:

- The engine does not start during test 1
- The engine does start during tests 2, 3 and 4
- The engine continues to run during tests 5 and 6

Refer to the chart below for each test and follow the check (✓) marks across the chart. Turn off the engine between each test.

TEST 1: The test shows the normal engine start procedure. The operator is in the seat, parking brake is engaged, the steering control levers are in the NEUTRAL position and the PTO switch is in the OFF (down) position. The engine will start.

TEST 2: The engine must not start if the PTO switch is in the ON position.

TEST 3: The engine must not start if the parking brake is disengaged.

TEST 4: The engine must not start if the steering control lever(s) is out of the NEUTRAL position.

TEST 5: Start the engine with the normal procedure. Turn on the PTO switch and lift your weight off the seat. The engine must stop. The cutting unit blades must not rotate after seven (7) seconds.

TEST 6: Start the engine with the normal procedure. Disengage the parking brake and lift your weight off the seat. The engine must stop. The cutting unit blades must not rotate after seven (7) seconds.

Test	Operator Seated		PTO Switch OFF		Parking Brake Engaged		Steering Control Levers in Neutral		Engine Starts	
	Yes	No	Yes	No	Yes	No	Yes	No	Yes	No
1	✓		✓		✓		✓		✓	
2	✓			✓	✓		✓			✓
3	✓		✓			✓	✓			✓
4	✓		✓		✓			✓		✓
5	✓	★	✓	★	✓		✓		★	
6	✓	★	✓		✓	★	✓		★	

★ Start the engine with the normal procedure, move position of the switch and lift your weight off the seat. The engine must stop immediately and the cutting unit blades must not rotate after seven (7) seconds.

7.3 OPERATING PROCEDURE

WARNING

This mower has a folding Roll Over Protection Structure (ROPS). Always wear the seat belt with the ROPS frame in the vertical and locked position. Never wear the seat belt with the ROPS in the folded position or when ROPS is not installed.

If the mower is over turning and the ROPS is in the vertical and locked position, hold the steering wheel. Do not try to move off the mower or leave the seat.

CAUTION

To prevent injury, always wear the safety glasses, leather work shoes or boots, a hard hat and ear protection.

1. Always start the engine with the operator in the seat, never while next to the mower. Never start the engine with persons near the mower.
2. Never operate the engine without enough ventilation or in an enclosed area. The carbon monoxide in the exhaust fumes can increase to dangerous levels.
3. Keep your hands and feet away from moving parts and the cutting units. When possible, do not adjust the mower with the engine started.
4. Do not operate the mower with loose or damaged components. All components must be correctly fastened to the mower. Mow when the grass is dry to get the best results.
5. First cut in a test area so that you completely understand the operation of the tractor and controls.
6. Inspect the area to find the safest procedure for the mower. Check the height of the grass, the type of terrain and the conditions of the surface. Each condition needs the correct adjustments and precautions.
7. Do not release the cut grass in the direction of persons or allow persons near the mower while in operation. The owner and operator are responsible for injuries caused to persons near the mower and any damage to their property.

CAUTION

Remove all objects you can find before you operate the mower. Carefully enter a new area and always operate at speeds that allow you to control the mower safely.

8. Be careful when you operate near to gravel areas (roads, parking areas, cart paths). Stones released from the equipment can cause injuries to persons and cause damage to the equipment.
9. When you are not mowing grass, always turn off the PTO switch.
10. Before you move across or operate on the paths or roads, turn off the PTO switch, lift the cutting unit and travel at decreased speed. Look for traffic.
11. When you hit an object or mower starts to cause vibration that is not normal, inspect the mower for damage and make repairs.

WARNING

Before you clean, adjust or repair this equipment, always turn off the PTO switch, lower the cutting unit to the ground, turn on the parking brake switch, stop the engine and remove the ignition key.

12. Travel at decreased speed and be careful when you operate on slopes or near sharp edges.
13. When you drive in the reverse direction, look behind you and down to make sure the path is clear. Use caution when you go near corners, trees or other objects that can prevent a clear view.
14. Never use your hands to clean the cutting units. Use a brush to remove the grass clippings from the blades. The blades are sharp and can cause injuries.

7 OPERATION

7.4 STARTING THE ENGINE

Start the engine with the operator in the seat, steering controls levers in the Neutral position, the PTO switch in the OFF position and the parking brake engaged.

Set the throttle lever to half throttle.

Kawasaki Engines - If the engine is cold, move the choke to the choke position.

Turn the ignition switch to the RUN position. The hour meter will show the engine operation hours.

Turn the ignition switch to the START position. Release the key when the engine starts. Allow 30 seconds between start tries to allow the starter motor to become cool.

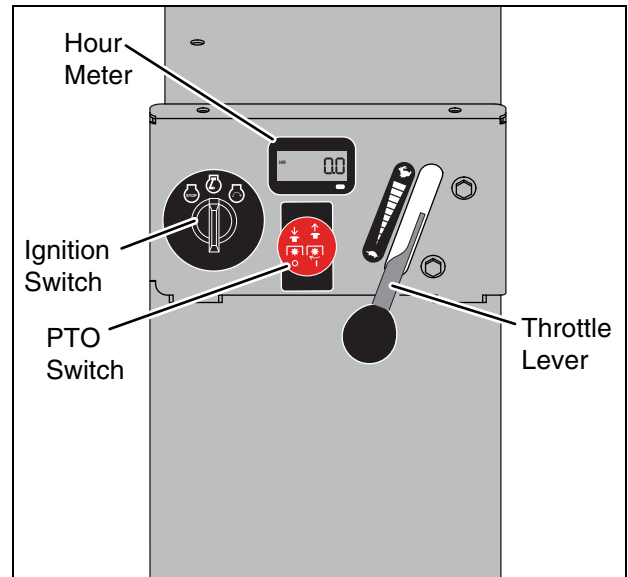

NOTICE

Do not hold the ignition switch in the START position for more than 5 seconds.

When the engine starts, move the choke to the RUN position. Allow the engine to become warm before you operate the engine at full throttle.

7.5 TO STOP THE ENGINE

To stop and park the mower in normal conditions:

1. Turn the PTO switch to the OFF position. Drive the mower to a flat and level area to park the mower.
2. Put the steering control levers in the Neutral position.
3. Lower the cutting unit to the ground. Engage the parking brake.
4. Turn the ignition switch to the OFF position and remove the key before you leave the mower.

If an emergency occurs and you must park the mower in the area of operation, follow the guidelines set by the grounds manager. If the mower is parked on a slope, chock or block the wheels.

7.6 DRIVING

Read and follow all safety instructions contained in this manual when you operate the mower. When you operate in the reverse direction, look behind you to make sure you have a clear path. Do not mow in reverse.

Slowly and equally push both the right-side and left-side control levers forward to drive the mower in the forward direction. The more the levers are pressed the more the forward speed is increased.

DANGER

To prevent personal injury or death, do not quickly move the steering control levers or suddenly start and stop the mower. You must use more caution when you turn the mower or when you operate on slopes.

Slowly and equally pull both the right-side and left-side control levers toward you to drive the mower in the reverse direction. The more the levers are pulled the more the reverse speed is increased. Press the levers against the reverse stop for the maximum reverse speed.

To turn the mower to the left, push the right-side drive lever more than the left-side drive lever. The greater the difference in lever position, the sharper the mower will turn. To do a zero radius left turn, press the right-side lever forward and pull the left-side lever toward you.

To turn the mower to the right, push the left-side drive lever more than the right-side drive lever. The greater the difference in lever position, the sharper the mower will turn. To do a zero radius right turn, press the left-side lever forward and pull the right-side lever toward you.

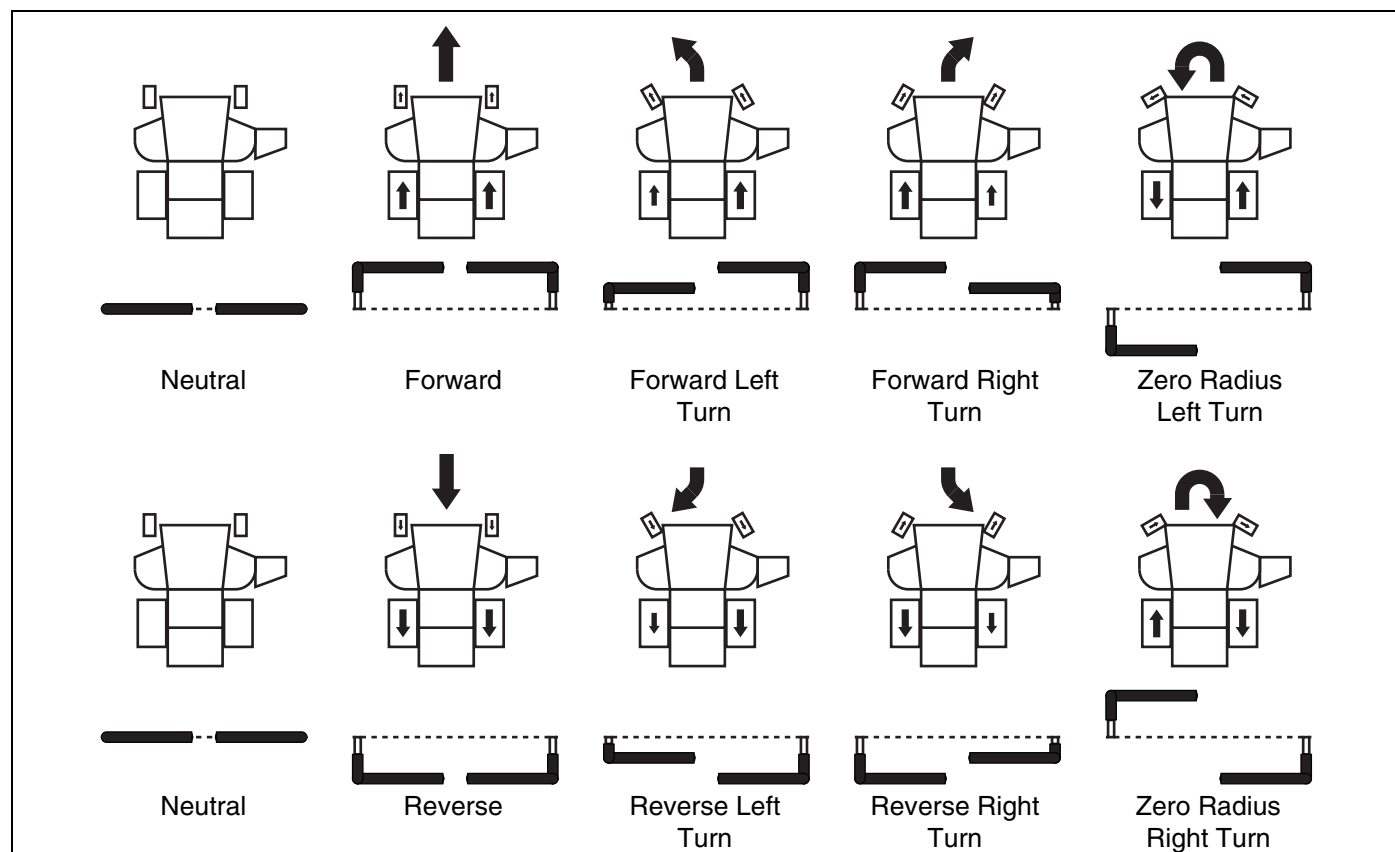

7 OPERATION

7.7 HEIGHT OF CUT

The height of cut is determined by the position of the HOC pin. Engage the parking brake, stop the engine and remove the key before you change the HOC. Fully lift the deck until it is held with the lift stop lever.

Use the chart to find the correct cutting height pin location for the necessary HOC.

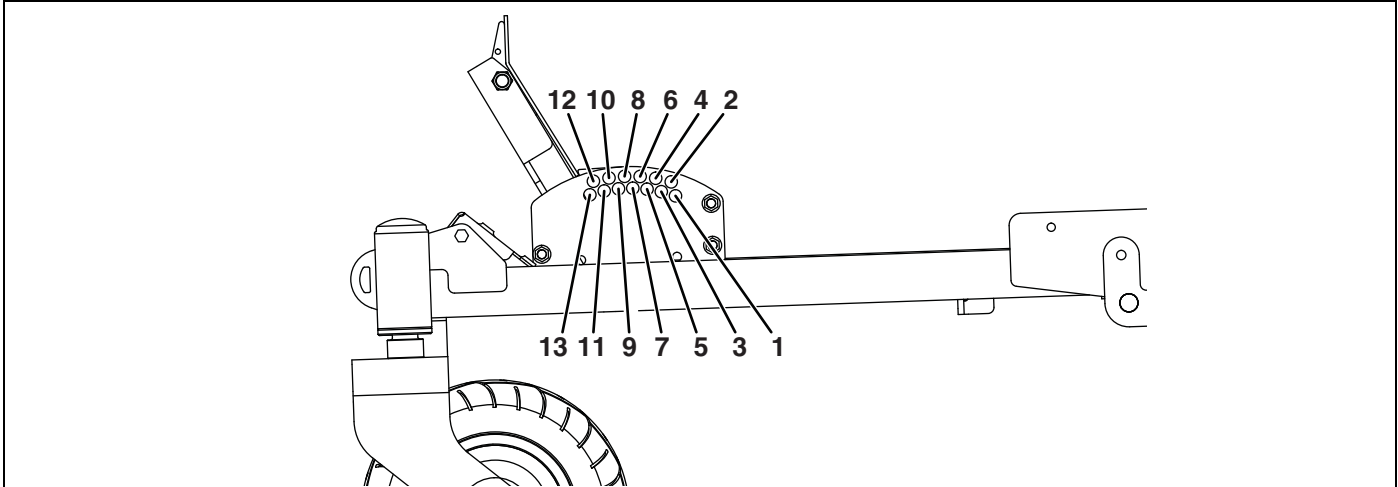

Hole	HOC	Hole	HOC
1	1-1/2 Inch (3.8 cm)	8	3-1/4 Inch (8.3 cm)
2	1-3/4 Inch (4.4 cm)	9	3-1/2 Inch (8.9 cm)
3	2 Inch (5.1 cm)	10	3-3/4 Inch (9.5 cm)
4	2-1/4 Inch (5.7 cm)	11	4 Inch (10.2 cm)
5	2-1/2 Inch (6.4 cm)	12	4-1/4 Inch (10.8 cm)
6	2-3/4 Inch (7.0 cm)	13	4-1/2 Inch (11.4 cm)
7	3 Inch (7.6 cm)		

7.8 MOWING

WARNING

To prevent injuries, when the blades rotate, keep your hands, feet and clothing away from the cutting unit.

NEVER use your hands to clean the cutting unit. Use a brush to remove grass from the blades. The blades can be sharp and can cause injury.

DO NOT operate the cutting unit with the discharge chute removed.

To mow:

1. Put the PTO switch in the ON position. The blades will start turning.
2. Lower the cutting unit.
3. Push the steering control levers forward to drive the mower. Never mow in the reverse direction.
4. Slow down when you turn the mower or mow on slopes.

7.9 MOWING ON SLOPES

The mower is made to have good traction and to have good balance. Operate the mower with caution when you drive on a slope. If you drive on wet grass, the traction and steering control of the mower is decreased.

WARNING

To make sure that the mower does not turn over, the safest method to drive on a slope is to drive vertically. Travel at a slow speed and do not make turns that are not necessary.

Check for hazards on the road that are not visible to the drivers. Keep the cutting unit lowered when you operate on the slopes.

CAUTION

When you are mowing on sides of hills, do not operate the mower on slopes greater than 5° or a 8.7% grade.

When you are mowing going uphill, do not operate the mower on slopes greater than 10° or a 17.6% grade.

When you are mowing going downhill, do not operate the mower on slopes greater than 15° or a 26.8% grade.

1. Always cut the grass with the engine at full throttle. Control the forward speed with the steering control levers to keep the correct performance.
2. If the mower moves to the side or the tires damage the turf, drive the mower on a slope with a decreased angle.
3. If the mower continues to move to the side and damage the turf, the slope is at an angle that is not safe. Do not continue to drive toward the top of the slope. Carefully drive toward the bottom of the slope.
4. When you drive toward the bottom of a slope with a high angle, lower the cutting unit to the ground. This procedure makes sure the mower does not turn upside down.
5. Correct tire pressure is necessary for maximum traction.

Rear - 8-10 psi (0.55-0.69 BAR)

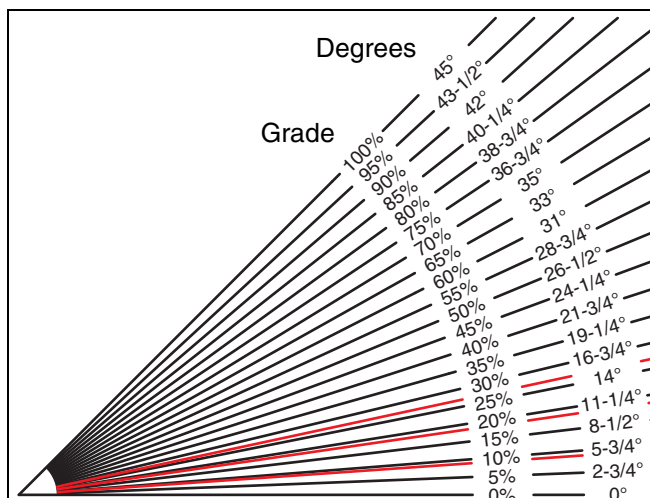
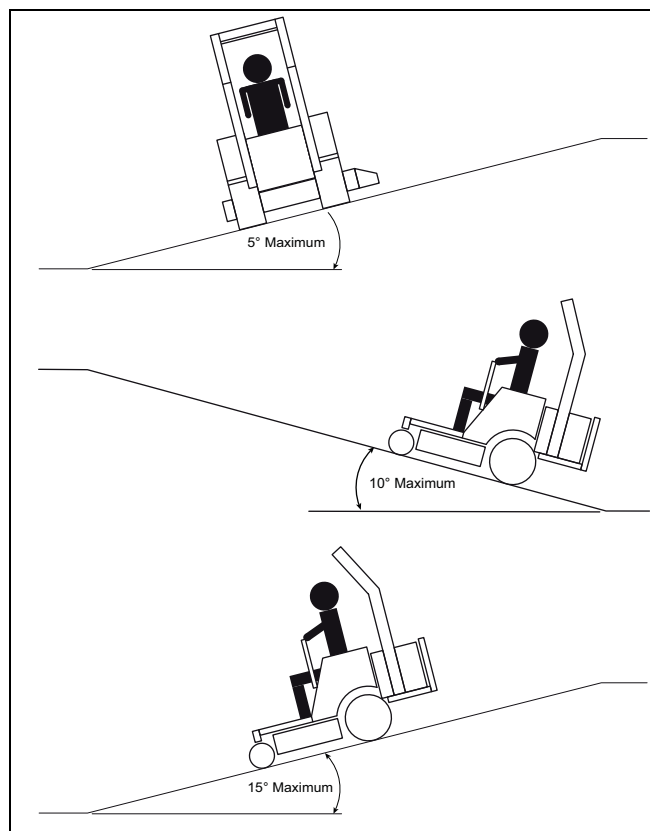

General slope of roadway embankment - 45°
 Steepest Grass Area - 31°
 Slope of the average roof - 19-1/4°
 2nd Class highway maximum grade 4-1/2°
 Toll road or freeway - 1-3/4°

7 OPERATION

How to calculate a slope:

Tools Required:

Level **(A)**, either 1 yard, or 1 meter long.

Tape measure **(B)**.

Use the level **(A)** and position it horizontally to measure the distance **(C)** with tape measure **(B)**. Use the chart to calculate the slope angle or the percentage grade of the slope **(D)**.

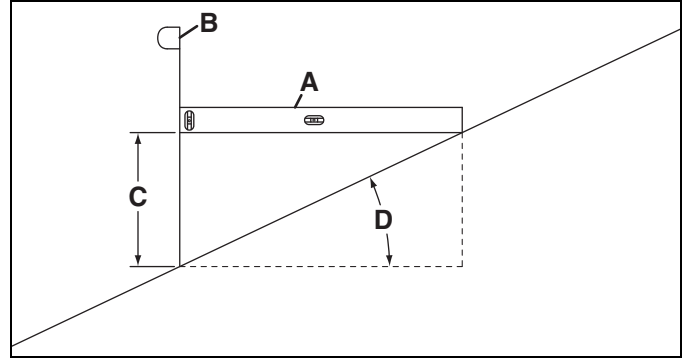

Height (C)		Result (D)	
Inches with 1 Yard Level (A)	Millimeters with 1 Meter Level (A)	Slope in Degrees	Slope Grade %
3		4.8	8.3
	100	5.7	10.0
	150	8.5	15
6		9.5	16.7
	200	11.3	20.0
7.5		11.8	20.8
	225	12.7	22.5
9		14	25.0
	275	15.4	27.5
10		15.5	27.8
	300	16.7	30.0
11		17.0	30.6
	325	18.0	32.5
12		18.4	33.3
	350	19.3	35.0
13		19.9	36.1
	375	20.6	37.5
14		21.3	38.9
	400	21.8	40.0
15		22.6	41.7
	425	23.0	42.5
16		24	44.4
	475	25.4	47.5
18		26.6	50.0
20		29.1	55.6
	600	31.0	60.0
25		34.8	69.4
	800	38.7	80.0
30		39.8	83.3
	900	42.0	90
36		45.0	100
	1000		

7.10 TOWING THE MOWER

If the mower has a problem and can not drive to the service area, move the neutral release levers to the neutral position and load the mower on a trailer. If a trailer is not available, tow the mower at a slow speed for short distances.

Be careful when you load or unload the mower on the trailer. Fasten the mower to the trailer to prevent the mower to move on the trailer. Engage the parking brake.

If the trailer is moved on the highway, inflate the tires to the maximum pressure recorded on the tire before you fasten the mower to the trailer. Decrease the tire pressure after the mower is removed from the trailer.

Move the neutral release levers **(B)** to the neutral position on both drive axles before you tow the mower. The neutral release levers lets the mower be moved without the engine started and to prevent possible damage to the drive axles.

The neutral release levers **(B)** are located behind the drive axles. Move the neutral release levers toward the rear of the mower to the neutral position.

Before towing, disengage the parking brake and make sure the cutting unit is lifted.

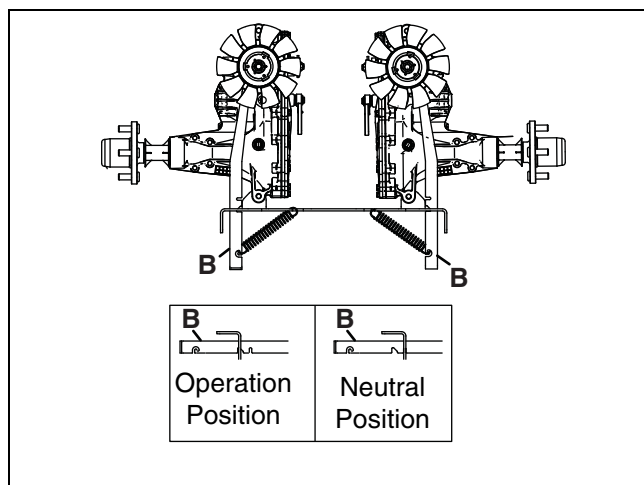

NOTICE

When you tow the mower, do not drive more than 2 mph (3.2 km/hr). Dixie Chopper recommends that you do not tow the mower for long distances.

When the mower gets to the service area, engage the parking brake and move the neutral release levers to the operation position.

8 MAINTENANCE AND LUBRICATION CHARTS

8.1 MAINTENANCE CHART

Mower Service Interval Chart		
Interval	Item	Section
First 5 Hours	<ul style="list-style-type: none"> Replace engine oil Replace engine oil filter Check electrical wiring 	See 9.3 See 9.3 See 9.16
Each day (10 Hours)	<ul style="list-style-type: none"> Check Safety Interlock System Check engine oil level Check drive axle oil level Clean area around muffler and controls Check blades for sharpness and wear 	See 7.2 See 9.3 See 9.9 See 9.14
Each 25 Hours	<ul style="list-style-type: none"> Clean air filter foam pre-cleaner¹ (Kohler Engine) Replace cutting blades 	
Each week (50 Hours)	<ul style="list-style-type: none"> Check fuel lines and fittings Inspect parking brake and steering control lever linkage Inspect deck and drive belts Check for loose components Check engine exhaust system Lubricate front wheel pivot grease fittings 	See 9.6 See 9.3
First 75 Hours	<ul style="list-style-type: none"> Replace drive axle fluid and filter (Two per mower) 	See 9.9
Each Two weeks (100 Hours)	<ul style="list-style-type: none"> Clean cylinder cooling fins¹ Replace air filter element¹ (Kohler Engine) Replace engine oil and filter^{1, 4} Clean and regap spark plugs (Kawasaki Engine) 	See 9.13 See 9.4 See 9.9 See 9.3
Each month (200 Hours)	<ul style="list-style-type: none"> Check electrical wiring Replace fuel filter (Kohler Engine) 	See 9.16
Each 250 Hours	<ul style="list-style-type: none"> Replace outer air filter element¹ (Kawasaki Engine) 	See 9.4
300 Hours	<ul style="list-style-type: none"> Clean combustion chamber (Kawasaki Engine)² Check and adjust valve clearance (Kawasaki Engine)² Clean and lap valve seating surface (Kawasaki Engine)² 	
Each two months (400 Hours)	<ul style="list-style-type: none"> Replace fuel filter Replace drive axle fluid 	See 9.9
Yearly or 500 Hours	<ul style="list-style-type: none"> Replace inner air filter element¹ (Kawasaki Engine) Replace spark plugs¹ Check and adjust valve clearance (Kohler Engine)³ 	See 9.4

¹ Perform more frequently under severe, dusty, dirty conditions.

² Have a Kawasaki authorized dealer perform this service

³ Have a Kohler authorized dealer perform this service

⁴ Refer to engine manual for engine manufacturer recommendations for oil filter and air filter replacement.

8.2 FLUID REQUIREMENTS

Fluid Requirements		
	Quantity	Type
Engine Oil with Filter Kawasaki Engine Kohler Engine	2.3 quarts (2.2 l) 2.0 quarts (1.9 l)	Varies depending on air temperature. See 4.6
Drive axle	2.41 quarts (2.28 liter) Each (2 per Mower)	SAE 20W-50 API Classification SL ⁵
Fuel	8 U.S. Gallons (30.3 l)	87 Octane Gasoline Maximum 10% Ethanol

⁵ If SAE 20W-50 oil is not available, you may substitute a motor oil of 55 SUS or better (at 230° F (110° C)), such as a high grade 10W-50, 15W-40 or 15W-50.

9 MAINTENANCE

9.1 GENERAL PRECAUTIONS

WARNING

Before you clean, adjust or repair this equipment, push PTO switch to the OFF position, lower the cutting unit, engage the parking brake, stop the engine and remove the key.

Make sure the mower is parked on a solid and level surface. Never work on a mower that is lifted only by the jack. Always use the jack stands.

A qualified technician must always do adjustments and maintenance. If the correct adjustments can not be made, contact your Dixie Chopper Dealer.

Inspect the equipment according to the maintenance schedule and keep complete records.

- a Keep the equipment clean.
- b Keep all moving parts correctly adjusted and lubricated.
- c Replace worn or damaged parts before you operate the mower.
- d Keep all fluids at the correct level.
- e Keep the shields in position and all hardware tight.
- f Keep the tires correctly inflated.

When you make the adjustments or repairs, do not wear jewelry or loose fitting clothing.

Refer to the illustrations in the Parts Manual for the removal and assembly of parts.

When you discard hazardous materials (batteries, lubricants, fuel, anti-freeze), follow your local, state or federal-recommended procedures.

9.2 ENGINE

IMPORTANT - The mower includes a separate Engine Manual prepared by the engine manufacturer. Read the Engine Manual and know the operation and maintenance of the engine. When you follow the engine manufacturer instructions, you will make sure of the maximum service life of the engine. The replacement engine manuals are available from the engine manufacturer.

The operation and maintenance during the first 5 hours of a new engine can make a difference to the performance and life of the engine.

During the first 5 hours of operation, Dixie Chopper recommends the following.

- Allow the engine to reach a temperature of at least 140° F (60° C) before operation at full load.
- Check the engine oil level two times each day. Higher than normal oil use can occur during the first 5 hours.
- Change the engine oil and oil filter after the first 5 hours of operation.
- Refer to the Engine manual for specified maintenance intervals.

NOTICE

The mower operates and cuts correctly at the preset governor setting. Do not change the engine governor setting or over speed the engine.

9.3 ENGINE OIL

Check engine oil level

Check the engine oil level before you start the engine or at least five minutes after you stop the engine.

- a Park the mower on a level surface.
- b The dipstick is found on the engine behind the seat. Remove the dipstick. Clean the dipstick with a cloth and replace in position.
- c Remove the dipstick and check the oil level. The oil level must be between the two level indicators on the dipstick.

Change Engine Oil and Filter

- a Start the engine to increase the temperature, then stop the engine.
- b Place a container capable of holding one gallon under the engine.
- c Remove the oil drain plug and allow the engine oil to drain into a container.
- d Remove the oil filter.
- e Let the engine oil flow into a container.
- f Clean the filter area on the engine.
- g Apply a thin layer of oil to the gasket on new filter. Install the oil filter.
- h Tighten the filter until the gasket contacts the oil filter adapter, then tighten an additional 1/2 to 3/4 turn. Only use your hand to tighten the filter.
- i Replace the oil drain plug and fill the engine with the correct quantity and grade of oil through the dipstick tube.
- j Start the engine and check around the oil filter gasket for leaks.
- k Stop the engine and check the engine oil level.

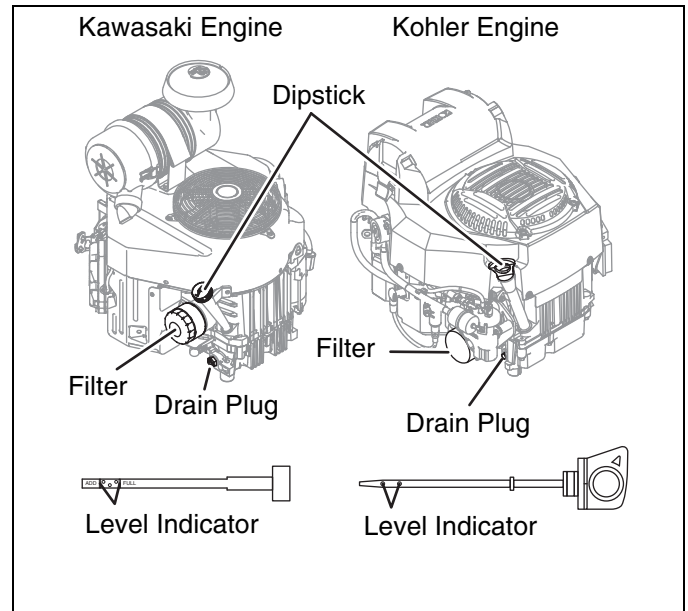

CAUTION

The engine oil can damage your skin. Use gloves when you use engine oil. If engine oil touches your skin, clean the area immediately.

Discard used engine oil as shown in local regulations.

9 MAINTENANCE

9.4 ENGINE AIR FILTER

Refer to the Engine Manual for any specific requirements for servicing the air filter.

Do not remove the filter to inspect air cleaner. Removal of the filter that is not necessary increases the risk of dust and other particles to enter the engine.

Kohler Engines - Clean the foam filter every 25 hours. Replace the filter every 100 hours.

Kawasaki Engines - Replace the outer element every 250 hours. Replace the inner element every 500 hours.

Clean the inside of the filter housing. Make sure dust and other particles do not get into the engine inlet.

Inspect the new filter. Do not use a damaged filter and never use an incorrect filter.

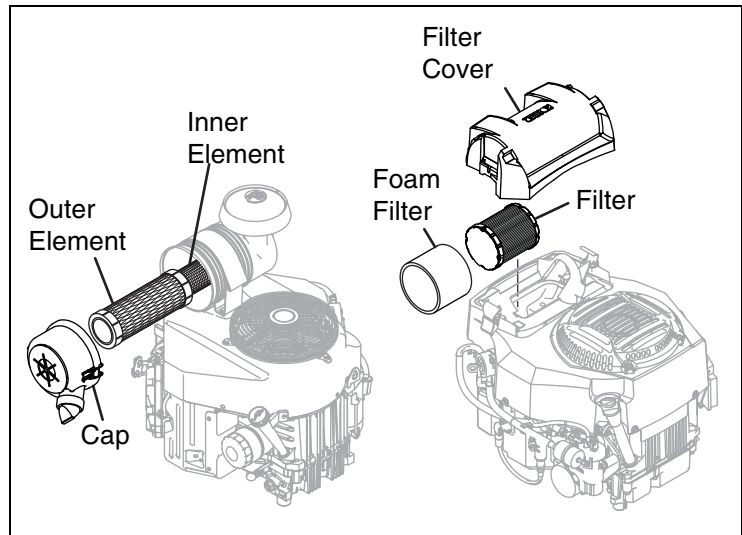

9.5 ENGINE EXHAUST

WARNING

The exhaust fumes contain carbon monoxide. The carbon monoxide in the exhaust fumes can increase to dangerous levels. To protect you from carbon monoxide poisoning, inspect the complete exhaust system every month and replace damaged components immediately.

NEVER operate the engine without enough ventilation.

The temperature of the exhaust components can be greater than 300° F (149° C). To prevent the burns, do not touch a hot exhaust system.

If you sense a change in the color or sound of the exhaust, stop the engine immediately. Identify the problem and have the system repaired.

Torque all exhaust manifold hardware equally. Tighten or replace the exhaust clamps.

9.6 FUEL

Gasoline is flammable. Use caution when you add the fuel to the mower. Only use an approved container. The spout on the container must fit inside the fuel filler neck. Never use the containers that are not approved to keep or transfer fuel.



WARNING

Refuel the mower before you start the engine. When the engine is in operation or while the engine is hot, never remove the fuel cap or add fuel to the mower.

Refuel outdoors only and do not smoke when you add fuel.

If the fuel spills, do not try to start the engine, but move the mower away from the area. Until fuel vapors are removed, do not allow the sparks, open flame or other types of ignition.

Never keep fuel containers near an open flame or any device that can cause the ignition of fuel or fuel vapors.

Always tighten the fuel tank cap and container cap after you add fuel.

Fill the fuel tank to the bottom of the filler neck.

Do not use premium gasoline or an oil-gasoline mixture. Use clean, fresh, regular unleaded gasoline, 85 octane minimum. When using blended fuel, do not use a blend with more than 10% ethanol. Under no circumstances should you use a blend with methanol. Refer to the engine's operator manual for fuel recommendations when using blended fuel.

Check fuel hoses and clamps every 50 hours. Replace fuel hoses and clamps at first indication of wear or damage.

Keep fuel according to your local, state or federal regulations and instructions from your fuel supplier.

Never allow the tank to become empty.

9.7 CHARGE THE BATTERY



WARNING

Charge the battery in an area with good airflow. The battery can release hydrogen gas that is explosive. To prevent an explosion, keep any device that can cause sparks or flames away from the battery.

When the battery charger is turned on, to prevent injury, stay away from the battery. A battery that is damaged can cause an explosion.

Read the battery charger manual for specified instructions on the operation of the charger.

When possible, remove the battery from the mower before you charge the battery. If the battery is not sealed, check and make sure the level of the electrolyte is above the plates in all of the cells.

Make sure the battery charger is turned OFF, then connect the battery charger to the battery terminals as specified in the battery charger manual.

Always turn OFF the battery charger before you disconnect the battery charger from the battery terminals.

9 MAINTENANCE

9.8 BATTERY

Before you service the battery, make sure the ignition switch is in the OFF position and the key is removed.

CAUTION

When you service the battery, always use the tools with insulation, wear protective glasses and protective clothing.
Discard used batteries as shown in your local regulations.

WARNING

The battery contains corrosive acid. Prevent contact with the battery acid.
Always wash your hands after you service a battery.

WARNING

The battery posts, battery terminals and related accessories contain lead and lead compounds, chemicals known to the State of California to cause cancer and other reproductive harm.

Tighten the battery cables on the battery terminals, To prevent corrosion, apply a layer of silicone dielectric grease to battery terminals and ends of cables. Keep the vent caps and battery terminal covers in position.

Before you do any welding operation on the mower, always disconnect the battery cables from the battery.

Confirm the battery polarity before you connect or you disconnect the battery cables.

When you install the battery, always connect the positive (RED) battery cable before the negative (BLACK) battery cable.

When you remove the battery, always disconnect the negative (BLACK) battery cable before the positive (RED) battery cable.

Jump-Starting the Mower

- a Before you try to jump-start the mower, check the condition of the drained battery.
- b Connect the positive (+) battery terminal of the charged battery to positive battery terminal of the drained battery.
- c Connect the negative (-) battery terminal of the charged battery to frame of vehicle with the drained battery.

WARNING

The battery can release hydrogen gas that is explosive. To decrease the risk of an explosion, prevent sparks near the battery. Always connect the negative jumper cable to the frame of the mower with the drained battery.

- d When the cables are connected, start the engine on the vehicle with the good battery, then start the mower.

9.9 DRIVE AXLE FLUID

Drain and replace the drive axle fluid and filter after the first 75 hours and each 400 hours.

Always replace the filter when you replace the drive axle fluid.

- a Clean the area around the vent plug, expansion bottle cap and filter to prevent dirt to enter the drive axle.
 - b Place a container capable of holding one gallon (4 liters) under the drive axle.
 - c Remove the 3 filter guard screws, the filter guard and the filter. Remove the cap from the expansion bottle. Allow the fluid to drain into the container.
 - d After the oil has drained, clean the filter mounting surface. Apply a thin film of oil to the filter gasket and assemble the filter to the drive axle. Tighten the filter until the gasket contacts the filter base, then tighten an additional 3/4 to 1 turn. Only use your hand to tighten the filter.
 - e Assemble the filter guard and the guard screws. Torque the screws to 65 in. lb. (7.3 Nm).
 - f Repeat steps a~e for the other axle.
 - g Remove the vent plug from both drive axles. Add fluid to the expansion bottle until the oil level reaches the bottom of the vent. Assemble the vent plug. Torque the plug to 180 in. lb. (20.3 Nm)
 - h Add oil until the fluid is at the FULL COLD line on the expansion bottle. Assemble the expansion bottle cap.
- After the drive axle fluid is changed, the air must be removed from the drive axles. Lift the rear wheels off the ground. Support the mower with jack stands.

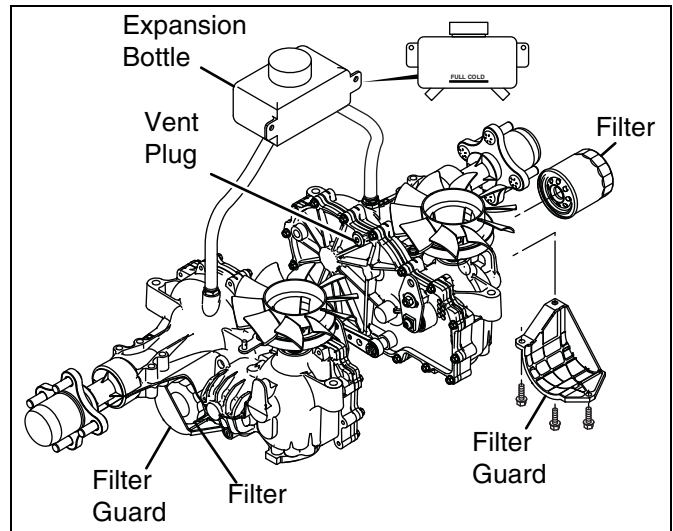

! WARNING

Make sure the mower is parked on a solid and level surface. Never work on a mower that is supported only by the jack. Always use jack stands.

Put chocks in front of and behind the front wheels.

! CAUTION

When you remove the air from the drive axles, the rear wheels will turn. To prevent injury, use caution to prevent contact with the wheels.

- a Start the engine and disengage the parking brake.
- b Move the neutral release levers to the Neutral position. Slowly move the steering control levers from the Neutral Position, to the full forward position, to the full reverse position and return the handles to the Neutral position. Repeat 5 to 6 times.
- c Move the neutral release knobs to the Normal Operation position. Slowly move the steering control levers from the Neutral Position, to the full forward position, to the full reverse position and return the handles to the Neutral position. Repeat 5 to 6 times.
- d Stop the engine and add fluid to the expansion bottle until the fluid is at the FULL COLD line.
- e If needed, repeat steps a~d until the drive axles operate at normal noise levels and the tires move smoothly in the forward and reverse directions.

9 MAINTENANCE

9.10 TIRES

Keep the tires correctly inflated to increase tire life. Inspect the tread wear.

Check the tire pressure each day, while the tires are cool. Use an accurate low-pressure tire gauge.

Keep the rear tires inflated to 8-10 psi (0.55-0.69 BAR).



CAUTION

DO NOT try to put a tire on a rim unless you have the correct training, tools and experience. Incorrect mounting can cause an explosion which can cause injury.

9.11 WHEEL MOUNTING PROCEDURE



WARNING

Make sure the mower is parked on a solid and level surface. Never work on a mower that is supported only by the jack. Always use jack stands.

If only the front or back of the mower is lifted, put the chocks in front of and behind the wheels that are not lifted.

Remove dirt, grease and oil from the stud threads. Do not lubricate threads.

Put the wheel on the hub. Inspect the wheel to make sure of full contact between surface of wheel and hub.

Tighten all hardware with your fingers, then torque hardware in a criss-cross order. When possible, tighten nuts in the top position.

Check and torque hardware each day until torque is kept at 65-75 ft.lb. (88-102 Nm).

9.12 FOLDING ROPS

A folding Roll Over Protective Structure (ROPS) accessory is installed on this mower. Inspect the ROPS periodically for loose hardware or damage.

CAUTION

Keep the ROPS hardware correctly fastened. Do not do welding operations, drill, change or bend the ROPS. Replace damaged ROPS. Do not try to correct a damaged ROPS.

Every 400 hours, inspect the seat, seat belt, ROPS mounting hardware and ROPS frame for damage. Replace all damaged parts immediately. All replacement parts for the ROPS must be as specified in the Parts Manual.

Check and torque all ROPS hardware every 100 hours.

Only operate the mower with the ROPS in the folded position on flat and level surfaces. Do not operate the mower with the ROPS in the folded position on the slopes, near sharp edges or near water. **There is no roll over protection with the ROPS in the folded position.**

Folding the ROPS.

- a Remove the hair pin and ROPS pin from both sides of the ROPS.
- b Fold the ROPS toward the back of the mower.
- c Assemble the ROPS pin and hair pin to lock the ROPS in the folded position. **Never** wear the seat belt with the ROPS in the folded position.

WARNING

To prevent injury when you fold the ROPS, use caution to prevent your fingers crushed between moving and rigid parts of the ROPS.

Always wear the set belt with the ROPS frame in the vertical and locked position.

Never wear the seat belt with the ROPS in the folded position.

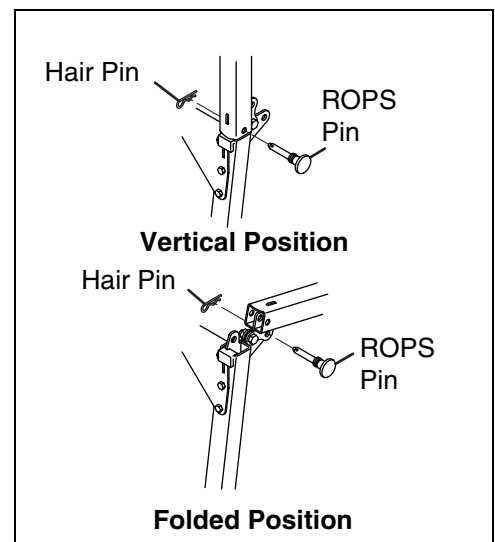

9 MAINTENANCE

9.13 AIR COOLING SYSTEM

The engine on the mower is an air-cooled engine. Dirt and other objects can decrease the air flow and cause the engine to overheat, cause bad performance and decreased engine life.

NOTICE

Do not use water to clean the engine. Water can cause contamination in the fuel system. Use a brush or clean cloth to clean the engine.

Use a brush or a dry cloth to clean the air intake area.

Keep throttle linkage, springs and controls clean.

Refer to the Engine manual for additional information.

9.14 INSPECTING BLADES

Every 50 hours of operation or when the cutting unit is removed from the mower, carefully inspect the blades to make sure the blades are in good condition. Replace any blade that has bends, grooves or cracks.

CAUTION

Be careful when you check blades to prevent pinching hands and fingers between ends of the blades.

WARNING

Never try to correct or repair a damaged blade. Always replaced a damaged blade.

The bends, grooves or cracks can cause a piece of the blade to become loose and be discharged from the mower. The broken blade pieces can cause injury to persons or property damage.

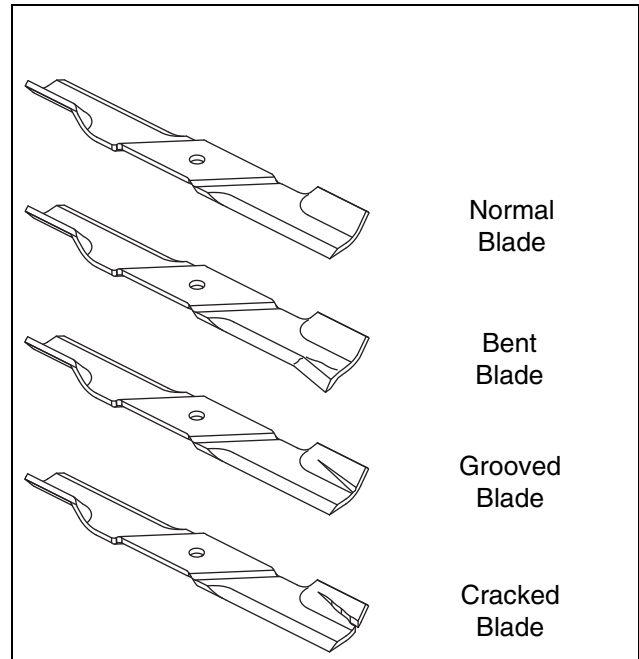

A bent blade can have a small crack that can increase and cause a piece of the blade to break. The bent blades can cause vibration and other stress on the mower.

The dust or sand particles can wear a dangerous groove in the blade between the air vanes and the flat part of the blade. The groove can quickly increase in size and allow a piece of the blade to break.

9.15 SHARPENING BLADES

Put a wooden block between the blade and cutting unit housing to prevent the blade to rotate.

 **WARNING**

Be careful and wear gloves when you check or service the cutting unit blades. Use a brush to remove grass clippings from the blades. The blades are sharp and can cause injuries.

When you remove more than one half inch of material, the blade tip can break and be discharged from the mower. The broken blade pieces can cause injury to persons or property damage.

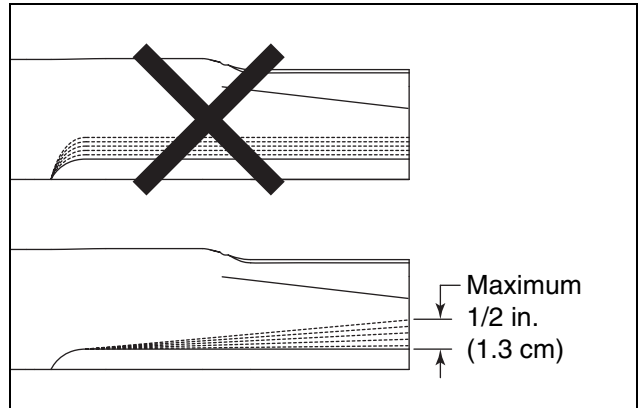

When you prepare or sharpen the blade, do not follow the original grind pattern. Grind new cutting edges at an angle. If the maximum of one half inch (1.3 cm) blade loss has occurred, do not sharpen more, replace the blade.

To prevent a blade that is not balanced, make sure an equal amount of material is removed from both ends of the blades. A blade that is not balanced will cause vibration and can damage the mower. Use a blade balancer to check the blade after you sharpen.

Torque center blade bolt to 115-130 ft.Lb. (156 to 176 Nm).

9.16 ELECTRICAL SYSTEM

 **CAUTION**

Always turn the ignition switch to the off position and remove the negative (BLACK) battery cable before you inspect or service the electrical system.

General precautions to decrease electrical problems are -

- Make sure that all the connections are clean and correctly fastened.
- Check the Interlock system and fuses at normal intervals. If the Interlock system does not operate correctly and you can not correct the problem, contact an authorized Dixie Chopper Dealer.
- Keep the wiring harness away from hot surfaces and moving parts.
- Check the battery and the charging system.
- Do not wash or pressure spray around electrical connections and components.

9 MAINTENANCE

9.17 BELTS

Replace the belts if they show signs of cuts, tears, burns caused by slipping or excessive wear.

To remove the belts, reduce belt tension by pulling the idler pulley away from the belt. Note the belt routing and remove the belts from the pulleys. The new belt must use the same belt routing.

**44 Inch (112 cm) Deck
Belt Routing**

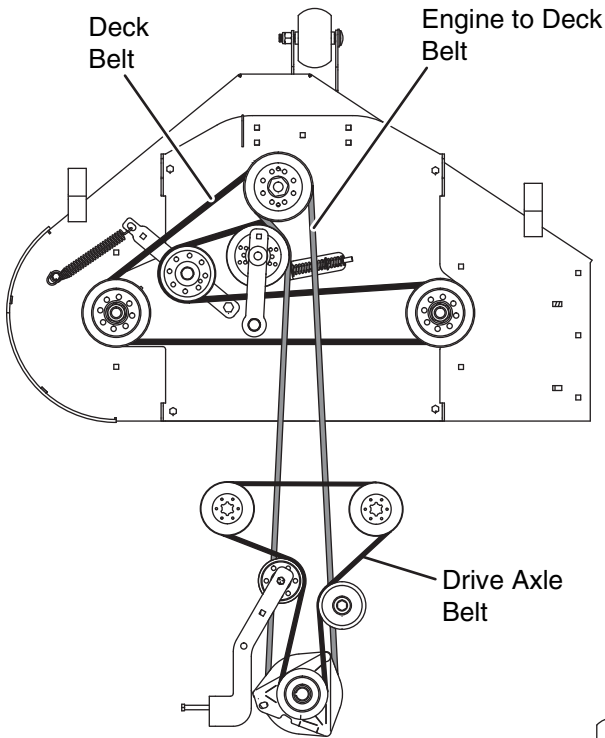

**50 Inch (127 cm) Deck
Belt Routing**

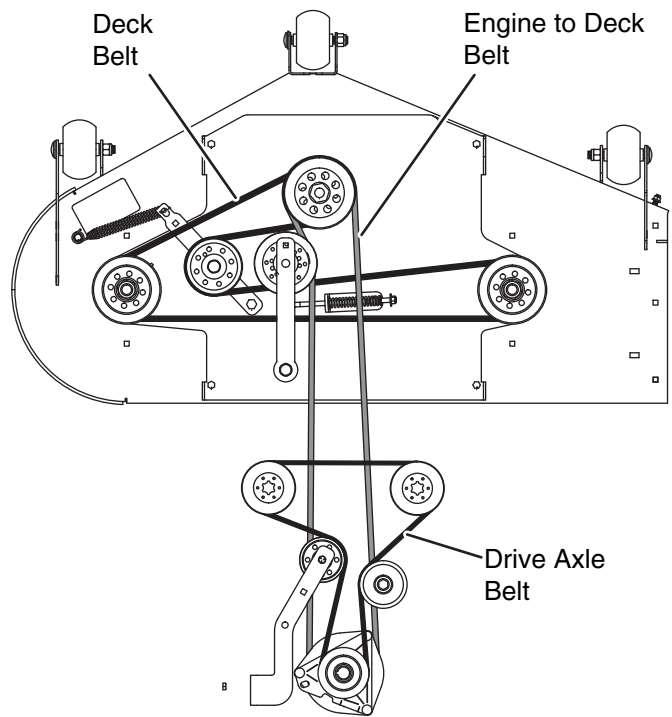

**60 Inch (152 cm) Deck
Belt Routing**

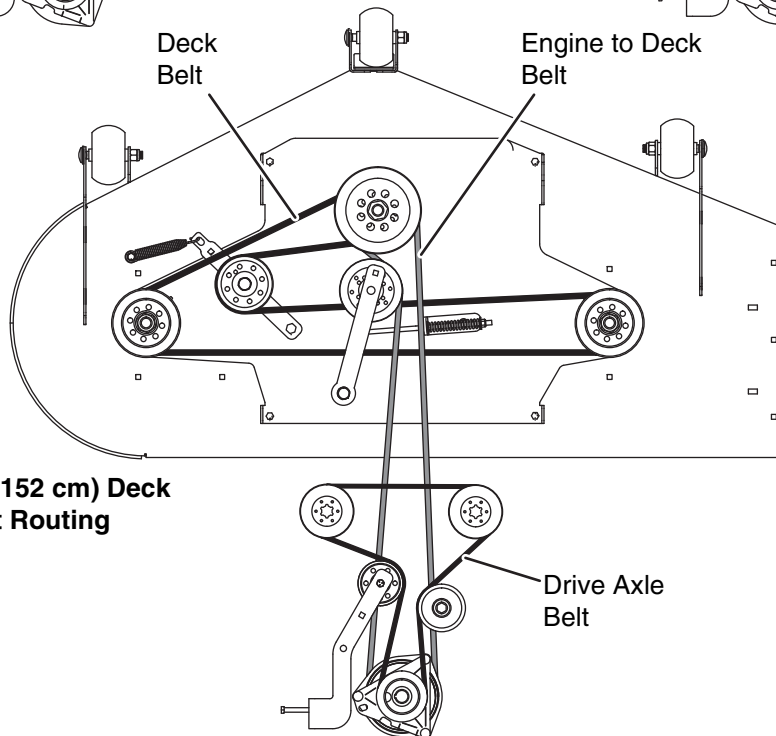

9.18 CARE AND CLEANING

Clean the mower and cutting units after each use. To prevent damage to the engine, do not wash the mower with the engine in operation. When possible, clean the mower with compressed air.

NOTICE

Do not wash any part of the mower that is hot. Do not use the high-pressure spray or steam. Use cold water and automotive cleaners.

Do not use a pressure washer to clean the deck. Water can get in and under seals and cause damage to the equipment

Use compressed air to clean the engine and the engine oil cooler fins. Do not pressure wash the engine.

Clean the underside of the deck frequently.

Use clean water to wash your equipment.

NOTICE

To use salt water or drain water is known to cause rust and corrosion of metal parts and can cause damage or failure. This damage is not included by the factory warranty.

Do not spray water at the control panel, ignition switch or other electrical components.

Clean all plastic or rubber parts with a weak soap solution or use commercially available rubber cleaners.

Repair damaged metal surfaces and use Dixie Chopper touch-up paint. Apply wax to the equipment for maximum paint protection.



CAUTION

To prevent fire, clean grass clippings and dirt from the cutting unit, drives, engine and exhaust components.



WARNING

Never use your hands to clean cutting units. Use a brush to remove grass clippings from the blades. The blades are sharp and can cause injuries.

9 MAINTENANCE

9.19 MOWER STORAGE

General

- Clean the mower and lubricate. Repair and paint damaged or open metal.
- Inspect the mower, tighten all hardware, replace worn or damaged components.
- Clean the tires and keep the mower so that the load is not on the tires. If the mower is not on the jack stands, check tires at normal intervals and add air when needed.
- Keep the mower and all accessories clean, dry and protected from the elements. Never keep the mower near an open flame or spark which can cause ignition of the fuel or fuel vapors.

Battery

- Remove, clean and keep the battery in the upright position on a surface that is not metal in a cool dry location. To prevent increased battery discharge, do not keep the battery on a metal surface.
- Check and charge the battery every 60 to 90 days.
- Keep the battery in a cool dry location. To decrease the self discharge rate, the temperature must not be more than 80° F (27° C) or less than 20° F (-7° C).

Engine

- Change the engine oil and filter.
- Clean the outside surface of the engine. Paint bare metal or apply a thin layer of rust preventative oil.
- Add a fuel stabilizer to prevent the fuel to become stale. See your fuel supplier for instructions. Start the engine. Operate the engine for two minutes to circulate the stabilizer throughout the fuel system.

Cutting Units

- Completely clean the cutting units. Repair and paint any damaged or bare metal surfaces.
- Lubricate all grease fittings and friction points.
- Apply a thin layer of rust preventative oil to the sharpened edges of the blades.



CAUTION

The cutting unit blades can have sharp edges. To prevent injury, use caution when you service or hold the blade.

After Storage

- Check and install the battery. If necessary, charge the battery.
- Check or service the fuel filter and air cleaner
- Check the level of engine oil and drive axle fluid.
- Fill the fuel tank with fuel.
- Make sure the tires are correctly inflated.
- Remove all oil from the blades.
- Start the engine at 1/2 throttle. Allow the engine to become warm and lubricated.



WARNING

Never operate the engine without enough ventilation or in an enclosed area. The carbon monoxide in the exhaust fumes can increase to dangerous levels.

10.1 GENERAL PRECAUTIONS

WARNING

Before you clean, adjust or repair this equipment, push PTO switch to the OFF position, lower the cutting unit to the ground, turn on the parking brake switch, stop the engine and remove the key.

Make sure the mower is parked on a solid and level surface. Never work on a mower that is lifted only by the jack. Always use the jack stands.

A qualified technician must always do adjustments and maintenance. If the correct adjustments can not be made, contact your Dixie Chopper Dealer.

Inspect the equipment according to the maintenance schedule and keep complete records.

- a Keep the equipment clean.
- b Keep all moving parts correctly adjusted and lubricated.
- c Replace worn or damaged parts before you operate the mower.
- d Keep all fluids at the correct level.
- e Keep the shields in position and all hardware tight.
- f Keep the tires correctly inflated.

When you make the adjustments or repairs, do not wear jewelry or loose fitting clothing.

Refer to the illustrations in the Parts Manual for the removal and assembly of parts.

When you discard hazardous materials (batteries, lubricants, fuel, anti-freeze), follow your local, state or federal-recommended procedures.

10.2 FORWARD SPEED LIMIT SCREWS

The cutting quality is improved at speeds lower than the full transport speed of the mower. The local turf condition may require a different speed.

To adjust the forward speed, adjust the speed limit screws at the base of the steering control lever. Turn the screws to the right-side to decrease the forward speed. Turn the screws toward the left side to increase the forward speed.

Make certain the speed limit screws on both sides of the mower are set to the same adjustment.

Test drive the mower. If the mower steers to the right or left when both steering control levers are pushed all the way forward, tracking adjustment may be required.

- If the mower steers to the right, adjust the speed limit screw on the left side of the mower to decrease the left drive axle speed.
- If the mower steers to the left, adjust the speed limit screw on the right side of the mower to decrease the right drive axle speed.

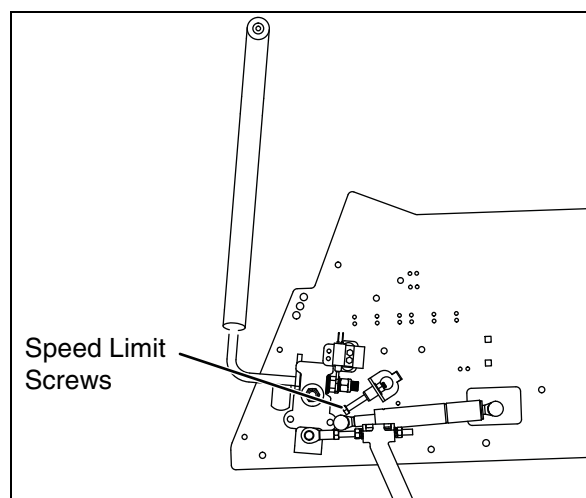





10 ADJUSTMENTS





10.3 TORQUE SPECIFICATION

NOTICE

The torque values included in these charts are approximate and are for reference only. Use these torque values at your risk. Dixie Chopper is not responsible for any loss, claim or damage caused by these charts. **Always use caution with torque values.**

Dixie Chopper uses Grade 5 (Inch) and Grade 8.8 (Metric) Plated bolts, unless a note is given. Always check the marks on the head of the bolts for the bolt grade. For tightening plated bolts, use the value given for lubricated.

SIZE	UNITS					SIZE	UNITS				
		Lubricated	Dry	Lubricated	Dry			Lubricated	Dry	Lubricated	Dry
#6-32	in-lb (Nm)	–	20 (2.3)	–	–	7/16-14	ft-lb (Nm)	37 (50.1)	50 (67.8)	53 (71.8)	70 (94.9)
#8-32	in-lb (Nm)	–	24 (2.7)	–	30 (3.4)	7/16-20	ft-lb (Nm)	42 (56.9)	55 (74.6)	59 (80.0)	78 (105)
#10-24	in-lb (Nm)	–	35 (4.0)	–	45 (5.1)	1/2-13	ft-lb (Nm)	57 (77.2)	75 (101)	80 (108)	107 (145)
#10-32	in-lb (Nm)	–	40 (4.5)	–	50 (5.7)	1/2-20	ft-lb (Nm)	64 (86.7)	85 (115)	90 (122)	120 (162)
#12-24	in-lb (Nm)	–	50 (5.7)	–	65 (7.3)	9/16-12	ft-lb (Nm)	82 (111)	109 (148)	115 (156)	154 (209)
1/4-20	in-lb (Nm)	75 (8.4)	100 (11.3)	107 (12.1)	143 (16.1)	9/16-18	ft-lb (Nm)	92 (124)	122 (165)	129 (174)	172 (233)
1/4-28	in-lb (Nm)	85 (9.6)	115 (13.0)	120 (13.5)	163 (18.4)	5/8-11	ft-lb (Nm)	113 (153)	151 (204)	159 (215)	211 (286)
5/16-18	in-lb (Nm)	157 (17.7)	210 (23.7)	220 (24.8)	305 (34.4)	5/8-18	ft-lb (Nm)	128 (173)	170 (230)	180 (244)	240 (325)
5/16-24	in-lb (Nm)	173 (19.5)	230 (26.0)	245 (27.6)	325 (36.7)	3/4-10	ft-lb (Nm)	200 (271)	266 (360)	282 (382)	376 (509)
3/8-16	ft-lb (Nm)	23 (31.1)	31 (42.0)	32 (43.3)	44 (59.6)	3/4-16	ft-lb (Nm)	223 (302)	298 404	315 (427)	420 (569)
3/8-24	ft-lb (Nm)	26 (35.2)	35 (47.4)	37 (50.1)	50 (67.8)	7/8-14	ft-lb (Nm)	355 (481)	473 (641)	500 (678)	668 (905)

SIZE	UNITS									Non Critical Fasteners into Aluminum
		Lubricated	Dry	Lubricated	Dry	Lubricated	Dry	Lubricated	Dry	
M4	Nm (in-lb)	–	–	–	–	–	–	3.83 (34)	5.11 (45)	2.0 (18)
M5	Nm (in-lb)	1.80 (16)	2.40 (21)	4.63 (41)	6.18 (54)	6.63 (59)	8.84 (78)	7.75 (68)	10.3 (910)	4.0 (35)
M6	Nm (in-lb)	3.05 (27)	4.07 (36)	7.87 (69)	10.5 (93)	11.3 (102)	15.0 (133)	13.2 (117)	17.6 (156)	6.8 (60)
M8	Nm (in-lb)	7.41 (65)	9.98 (88)	19.1 (69)	25.5 (226)	27.3 (241)	36.5 (323)	32.0 (283)	42.6 (377)	17.0 (150)
M10	Nm (ft-lb)	14.7 (11)	19.6 (14)	37.8 (29)	50.5 (37)	54.1 (40)	72.2 (53)	63.3 (46)	84.4 (62)	33.9 (25)
M12	Nm (ft-lb)	25.6 (19)	34.1 (25)	66.0 (48)	88.0 (65)	94.5 (70)	125 (92)	110 (81)	147 (108)	61.0 (45)
M14	Nm (ft-lb)	40.8 (30)	54.3 (40)	105 (77)	140 (103)	150 (110)	200 (147)	175 (129)	234 (172)	94.9 (70)

11.1 GENERAL

The problem solution chart lists basic problems that can occur during start and operation of the mower. For complete information about the hydraulic and electrical systems, contact your Dixie Chopper Dealer.

Symptoms	Possible Causes	Action
Engine will not start.	<ol style="list-style-type: none"> 1. Parking brake disengaged, PTO switch ON or steering levers out of neutral position. 2. Battery low on charge or defective. 3. Fuel tank empty or dirty. 4. Fuse blown. 5. Relay(s) defective. 	<ol style="list-style-type: none"> 1. Check Interlock System and start-up procedure. 2. Inspect condition of battery and battery connections. 3. Fill with fresh fuel. Change fuel filter. 4. Replace fuse. 5. Test and replace relay.
Engine hard to start or runs poorly.	<ol style="list-style-type: none"> 1. Fuel level low, fuel or fuel filter dirty. 2. Air cleaner dirty. 3. Engine problem. 	<ol style="list-style-type: none"> 1. Fill with fresh fuel. Change fuel filter. 2. Inspect, clean and/or replace air filter. 3. Consult engine manual.
Engine stops.	<ol style="list-style-type: none"> 1. Fuel tank empty. 2. Interlocks not set before leaving operator's position. 	<ol style="list-style-type: none"> 1. Fill with fresh fuel and bleed fuel lines. 2. Put steering levers in neutral position, engage parking brake and set PTO switch to OFF.
Engine overheating.	<ol style="list-style-type: none"> 1. Air intake restricted. 	<ol style="list-style-type: none"> 1. Clean engine cooling air intake and fins.
Battery not holding charge.	<ol style="list-style-type: none"> 1. Loose or corroded battery terminals. 2. Low electrolyte. 3. Charging system defective. 	<ol style="list-style-type: none"> 1. Inspect and clean terminals. 2. Refill to correct level. 3. See engine manual.
Cutting unit does not cut evenly.	<ol style="list-style-type: none"> 1. Deck not level. 2. Engine speed too low. 3. Mow speed not adjusted for turf conditions. 	<ol style="list-style-type: none"> 1. Check that decks are level. Check and adjust cutting height. 2. Check engine speed with throttle in its fast position. 3. Adjust mow speed for best cut.



DIXIE CHOPPER
6302 E. County Road 100 N.
Coatesville, Indiana 46121
www.dixiechopper.com

Specifications and instructions subject to change without notice.

Dixie Chopper and Magic Circle, are registered trademarks of Magic Circle Corporation
any and all use and/or reproductions are strictly prohibited.

Printed In USA