



SINGLE-ZONE FOUR-WAY CEILING-CASSETTE INSTALLATION MANUAL

**Single-Zone Four-Way
Ceiling-Cassette
Heat Pump Systems
3/4 to 3-1/2 Tons**



**LC098HV (9,000 Btu/h)
LC128HV (12,000 Btu/h)**



LC188HV (18,000 Btu/h)



LC249HV (24,000 Btu/h)



**LC369HV (36,000 Btu/h)
LC429HV (42,000 Btu/h)**

PROPRIETARY DATA NOTICE

This document, as well as all reports, illustrations, data, information, and other materials are the property of LG Electronics U.S.A., Inc., and are disclosed by LG Electronics U.S.A., Inc., only in confidence.

This document is for design purposes only.

Do not throw away, destroy, or lose this manual.

Please read carefully and store in a safe place for future reference.

Content familiarity required for proper installation.

The instructions included in this manual must be followed to prevent product malfunction, property damage, injury, or death to the user or other people. Incorrect operation due to ignoring any instructions will cause harm or damage. The level of seriousness is classified by the symbols described below.

A summary list of safety precautions begins on page 3.

For more technical materials such as submittals, engineering databooks, and catalogs, visit www.lghvac.com.

Proper sizing and installation of equipment is critical to achieve optimal performance. Split system air conditioners and heat pumps (excluding ductless systems) must be matched with appropriate coil components to meet ENERGY STAR® criteria. Ask your contractor for details or visit www.energystar.gov.

(ENERGY STAR and the ENERGY STAR mark are registered trademarks owned by the U.S. Environmental Protection Agency.)

IMPORTANT - This product has been designed and manufactured to meet ENERGY STAR criteria for energy efficiency when matched with appropriate coil components. However, proper refrigerant charge and proper air flow are critical to achieve rated capacity and efficiency. Installation of this product should follow the manufacturer's refrigerant charging and air flow instructions. **Failure to confirm proper charge and airflow may reduce energy efficiency and shorten equipment life.**

For continual product development, LG Electronics U.S.A., Inc., reserves the right to change specifications without notice.





©LG Electronics U.S.A., Inc.

This document, as well as all reports, illustrations, data, information, and other materials are the property of LG Electronics U.S.A., Inc.

SAFETY INSTRUCTIONS

The instructions below must be followed to prevent product malfunction, property damage, injury or death to the user or other people. Incorrect operation due to ignoring any instructions will cause harm or damage. The level of seriousness is classified by the symbols described below.

TABLE OF SYMBOLS

 DANGER	<i>This symbol indicates an imminently hazardous situation which, if not avoided, will result in death or serious injury.</i>
 WARNING	<i>This symbol indicates a potentially hazardous situation which, if not avoided, could result in death or serious injury.</i>
 CAUTION	<i>This symbol indicates a potentially hazardous situation which, if not avoided, may result in minor or moderate injury.</i>
 NOTE	<i>This symbol indicates situations that may result in equipment or property damage accidents only.</i>
Note:	<i>This symbol indicates information related to the current procedure.</i>
	<i>This symbol indicates an action that should not be performed.</i>

INSTALLATION

DANGER

 **Don't store or use flammable gas / combustibles near the unit.**

There is risk of fire, explosion, and physical injury or death.

Use only an appropriately sized vacuum pump and / or inert (nitrogen) gas when performing leak tests or purging air.  **Do not use compressed compress air, oxygen, or flammable gases.**

There is risk of fire, explosion, and physical injury or death.

WARNING

 **Do not install or remove the unit by yourself (end user). Ask the dealer or an LG trained service provider to install the unit.**

Improper installation by the user will result in water leakage, fire, explosion, electric shock, physical injury or death.

Always check for system refrigerant leaks during installation and after the unit has been installed or serviced.

Exposure to high concentration levels of refrigerant gas will lead to illness or death.

Wear protective gloves when handling equipment. Sharp edges will cause personal injury.

For replacement of an installed unit, always contact an LG trained service provider.

There is risk of fire, electric shock, explosion, and physical injury or death.

Dispose the packing materials safely.

- Packing materials, such as nails and other metal or wooden parts, will cause puncture wounds or other injuries.
- Tear apart and throw away plastic packaging bags so that children do not play with them and risk suffocation and death.

The unit is shipped with refrigerant and the service valves closed.  Do not open service valves on the unit until all non-condensibles have been removed from the piping system and authorization to do so has been obtained from the commissioning agent.

There is a risk of physical injury or death.

Install the unit considering the potential for strong winds or earthquakes.

Improper installation will cause the unit to fall over, resulting in physical injury or death.

 **Do not run the compressor with the service valves closed.**

There is a risk of explosion, physical injury, or death.

 **Do not change the settings of the protection devices.**

If the pressure switch, thermal switch, or other protection device is shorted and forced to operate improperly, or parts other than those specified by LG are used, there is risk of fire, electric shock, explosion, and physical injury or death.

Periodically check that the outdoor frame is not damaged.

There is a risk of explosion, physical injury, or death.

 **Do not install the unit on a defective stand.**

There is a risk of physical injury.

Replace all control box and panel covers.

If cover panels are not installed securely, dust, water and animals will enter the unit, causing fire, electric shock, and physical injury or death.

SAFETY INSTRUCTIONS

INSTALLATION - CONTINUED

▲WARNING

If the air conditioner is installed in a small space, take measures to prevent the refrigerant concentration from exceeding safety limits in the event of a refrigerant leak.

Consult the latest edition of ASHRAE (American Society of Heating, Refrigerating, and Air Conditioning Engineers) Standard 15. If the refrigerant leaks and safety limits are exceeded, it could result in personal injuries or death from oxygen depletion.

⊘ Do not install the unit on a defective stand.

There is a risk of physical injury.

▲CAUTION

Be very careful when transporting the product. Failure to follow these directions will result in minor or moderate physical injury.

- ⊘ Do not attempt to carry the product without assistance.
- Some products use polypropylene bands for packaging. ⊘ Do not use polypropylene bands to lift the unit.
- Suspend the unit from the base at specified positions.
- Support the unit a minimum of four points to avoid slippage from rigging apparatus.

▲NOTE

⊘ Don't install the unit where it's directly exposed to ocean winds.

Ocean winds will cause corrosion, particularly on the condenser and evaporator fins, which, in turn could cause product malfunction or inefficient performance.

When installing the unit in a low-lying area, or a location that is not level, use a raised concrete pad or concrete blocks to provide a solid, level foundation.

This will prevent water damage and reduce abnormal vibration.

Properly insulate all cold surfaces to prevent "sweating."

Cold surfaces such as uninsulated piping can generate condensate that will drip and cause a slippery surface condition and/or water damage to walls.

When installing the unit in a hospital, mechanical room, or similar electromagnetic field (EMF) sensitive environment, provide sufficient protection against electrical noise.

Inverter equipment, power generators, high-frequency medical equipment, or radio communication equipment will cause the air conditioner to operate improperly. The unit will also affect such equipment by creating electrical noise that disturbs medical treatment or image broadcasting.

⊘ Do not use the product for special purposes such as preserving foods, works of art, wine coolers, or other precision air conditioning applications. The equipment is designed to provide comfort cooling and heating.

There is risk of property damage.

⊘ Do not make refrigerant substitutions. Use R410A only. If a different refrigerant is used, or air mixes with original refrigerant, the unit will malfunction and be damaged.

Keep the unit upright and parallel during installation to avoid vibration or water leakage.

Install the unit in a safe location where nobody can step on or fall onto it.

There is risk of physical injury or death.

Properly insulate all cold surfaces to prevent "sweating."

Cold surfaces such as uninsulated piping can generate condensate that could drip, causing a slippery surface that creates a risk of slipping, falling, and personal injury.

⊘ Do not install the unit in a noise sensitive area.

When connecting refrigerant tubing, remember to allow for pipe expansion.

Improper piping will cause refrigerant leaks and system malfunction.

Take appropriate actions at the end of HVAC equipment life to recover, recycle, reclaim or destroy R410A refrigerant according to applicable U.S. Environmental Protection Agency (EPA) rules.

Periodically check that the outdoor frame is not damaged.

There is a risk of equipment damage.

Install the unit in a safe location where nobody can step on or fall onto it. ⊘ Do not install the unit on a defective stand.

There is risk of unit and property damage.

Install the drain hose to ensure adequate drainage.

There is a risk of water leakage and property damage.

⊘ Don't store or use flammable gas / combustibles near the unit.

There is risk of product failure.

Always check for system refrigerant leaks after the unit has been installed or serviced.

Low refrigerant levels will cause product failure

The unit is shipped with refrigerant and the service valves closed. ⊘ Do not open service valves on the unit until all non-condensibles have been removed from the piping system and authorization to do so has been obtained from the commissioning agent.

There is a risk of refrigerant contamination, refrigerant loss and equipment damage.

⊘ Do not run the compressor with the service valves closed.

There is a risk of equipment damage.

SAFETY INSTRUCTIONS

WIRING

⚠ DANGER

High voltage electricity is required to operate this system. Follow the National Electrical Codes and these instructions when wiring.

Improper connections and inadequate grounding can cause accidental injury or death.

Always ground the unit following local, state, and National Electrical Codes.

Turn the power off at the nearest disconnect before servicing the equipment.

Electrical shock can cause physical injury or death.

Properly size all circuit breakers or fuses.

There is risk of fire, electric shock, explosion, physical injury or death.

⚠ WARNING

The information contained in this manual is intended for use by an industry-qualified, experienced, certified electrician familiar with the U.S. National Electric Code (NEC) who is equipped with the proper tools and test instruments.

Failure to carefully read and follow all instructions in this manual can result in personal injury or death.

All electric work must be performed by a licensed electrician and conform to local building codes or, in the absence of local codes, with the National Electrical Code, and the instructions given in this manual.

If the power source capacity is inadequate or the electric work is not performed properly, it will result in fire, electric shock, physical injury or death.

Refer to local, state, and federal codes, and use power wires of sufficient current capacity and rating.

Wires that are too small will generate heat and cause a fire.

Secure all field wiring connections with appropriate wire strain relief.

Improperly securing wires will create undue stress on equipment power lugs. Inadequate connections will generate heat, cause a fire and physical injury or death.

⚠ NOTE

The information contained in this manual is intended for use by an industry-qualified, experienced, certified electrician familiar with the U.S. National Electric Code (NEC) who is equipped with the proper tools and test instruments.

Failure to carefully read and follow all instructions in this manual can result in equipment malfunction and property damage.

SAFETY INSTRUCTIONS

OPERATION

⚠ DANGER

- ⊘ Do not provide power to or operate the unit if it is flooded or submerged.

There is risk of fire, electric shock, physical injury or death.

Use a dedicated power source for this product.

There is risk of fire, electric shock, physical injury or death.

- ⊘ Do not operate the disconnect switch with wet hands.

There is risk of fire, electric shock, physical injury or death.

⚠ WARNING

- ⊘ Do not allow water, dirt, or animals to enter the unit.

There is risk of fire, electric shock, physical injury or death.

- ⊘ Avoid excessive cooling, and periodically perform ventilation to the unit.

Inadequate ventilation is a health hazard.

- ⊘ Do not touch the refrigerant piping during or after operation.

It can cause burns or frostbite.

- ⊘ Do not operate the unit with the panel(s) or protective cover(s) removed; keep fingers and clothing away from moving parts.

The rotating, hot, cold, and high-voltage parts of the unit can cause physical injury or death.

⚠ CAUTION

- ⊘ To avoid physical injury, use caution when cleaning or servicing the air conditioner.

⚠ NOTE

Clean up the site after installation is finished, and check that no metal scraps, screws, or bits of wiring have been left inside or surrounding the unit.

- ⊘ Do not use this equipment in mission critical or special-purpose applications such as preserving foods, works of art, wine coolers or refrigeration. The equipment is designed to provide comfort cooling and heating.

- ⊘ Do not block the inlet or outlet.

Unit will malfunction.

Use a soft cloth to clean the units. ⊘ Do not use wax, thinner, or strong detergents.

The exterior of the units may deteriorate, change color, or may be damaged if harsh cleaning chemicals are used.

Periodically verify that the hardware securing the unit has not deteriorated.

If the unit falls from its installed location, it can cause property damage, product failure, physical injury or death.

If gas leaks out, ventilate the area before operating the unit.

If the unit is mounted in an enclosed, low-lying, or poorly ventilated area, and the system develops a refrigerant leak, it will cause fire, electric shock, explosion, physical injury or death.

Periodically verify the equipment mounts have not deteriorated.

If the base collapses, the unit could fall and cause physical injury or death.

- ⊘ Do not open the inlet grille of the unit during operation.
- ⊘ Do not operate the unit with the panels or guards removed. ⊘ Do not insert hands or other objects through the inlet or outlet when the unit is plugged in. ⊘ Do not touch the electrostatic filter, if the unit includes one.

The unit contains sharp, rotating, hot, and high voltage parts that can cause personal injury and/or electric shock.

Securely attach the electrical part cover to the indoor unit and the service panel to the outdoor unit.

Non-secured covers can result in burns or electric shock due to dust or water in the service panel.

Securely attach the electrical part cover to the indoor unit and the service panel to the outdoor unit.

Non-secured covers can result in malfunction due to dust or water in the service panel.

Periodically verify the equipment mounts have not deteriorated.

If the base collapses, the unit could fall and cause property damage or product failure.

- ⊘ Do not allow water, dirt, or animals to enter the unit.

There is risk of unit failure.

TABLE OF CONTENTS

Safety Instructions	3-6	Electrical System Installation	46-53
General Data	8-14	<i>Safety Guidelines / Connections and Specifications</i>	46
<i>Unit Nomenclature</i>	8	<i>Connections and Specifications</i>	47-50
<i>Parts</i>	9	<i>Controller Options</i>	50
<i>Specifications</i>	10-12	<i>Indoor Unit Electrical Connections</i>	51
<i>Electrical</i>	14	<i>Using a Conduit / Outdoor Unit Electrical Connections</i>	52
General Installation Guidelines	15--27	<i>Outdoor Unit Electrical Connections</i>	53
<i>Outdoor Unit Location Selection</i>	15-17	Final Installation Procedures	54-80
<i>Required Outdoor Unit Clearances</i>	18-20	<i>Triple Leak / Pressure Test</i>	54-55
<i>Rigging and Lifting / Outdoor Unit Mounting</i>	21	<i>Deep Evacuation Test</i>	55-56
<i>Outdoor Unit Mounting</i>	22	<i>Triple Evacuation Test</i>	56-57
<i>Indoor Unit Location Selection</i>	23-24	<i>Refrigerant Trim Charge</i>	58
<i>Required Indoor Unit Clearances</i>	24	<i>Installing Batteries, Test Run</i>	59-60
<i>Hanging the Indoor Unit</i>	25-27	<i>Performance Evaluation</i>	60
<i>Drilling the Piping Hole</i>	27	<i>Installing the Panel</i>	61-64
General Refrigerant Piping System Information	28-37	<i>Installing the Branch Duct</i>	65-67
<i>Refrigerant Safety Standards</i>	28	<i>Branch Duct Options</i>	68-70
<i>Device Connection Limitations</i>	28	<i>Outside Air Ventilation</i>	71-72
<i>Selecting Copper Piping</i>	29	<i>Installer Setting Mode</i>	73-74
<i>Copper Expansion and Contraction</i>	30-31	<i>FC-15 and FC-6 / FC-35</i>	75
<i>Piping Materials and Handling</i>	32	<i>Setting LUU180-420HV Optional Modes</i>	76-80
<i>Refrigerant System Engineering</i>	33-35	Troubleshooting	81-85
<i>Flaring and Brazing Procedures</i>	36-37	<i>LG Monitoring View (LGMV) Diagnostic Software</i>	81-82
Refrigerant Piping Connections	38-45	<i>LG ThinQ</i>	83
<i>Installation Overview / Special Applications</i>	38	<i>Error Codes</i>	84-85
<i>Outdoor Unit Connections</i>	39-40	<i>Cautions for Refrigerant Leaks</i>	86
<i>Indoor Unit Connections</i>	41	Installation Checklist	87
<i>Outdoor Unit Condensate Piping</i>	42		
<i>Indoor Unit Condensate Piping</i>	42		
<i>Checking for Leaks / Bundling</i>	43		
<i>Insulation</i>	44-45		

GENERAL DATA

Unit Nomenclature

Indoor Units and Outdoor Units

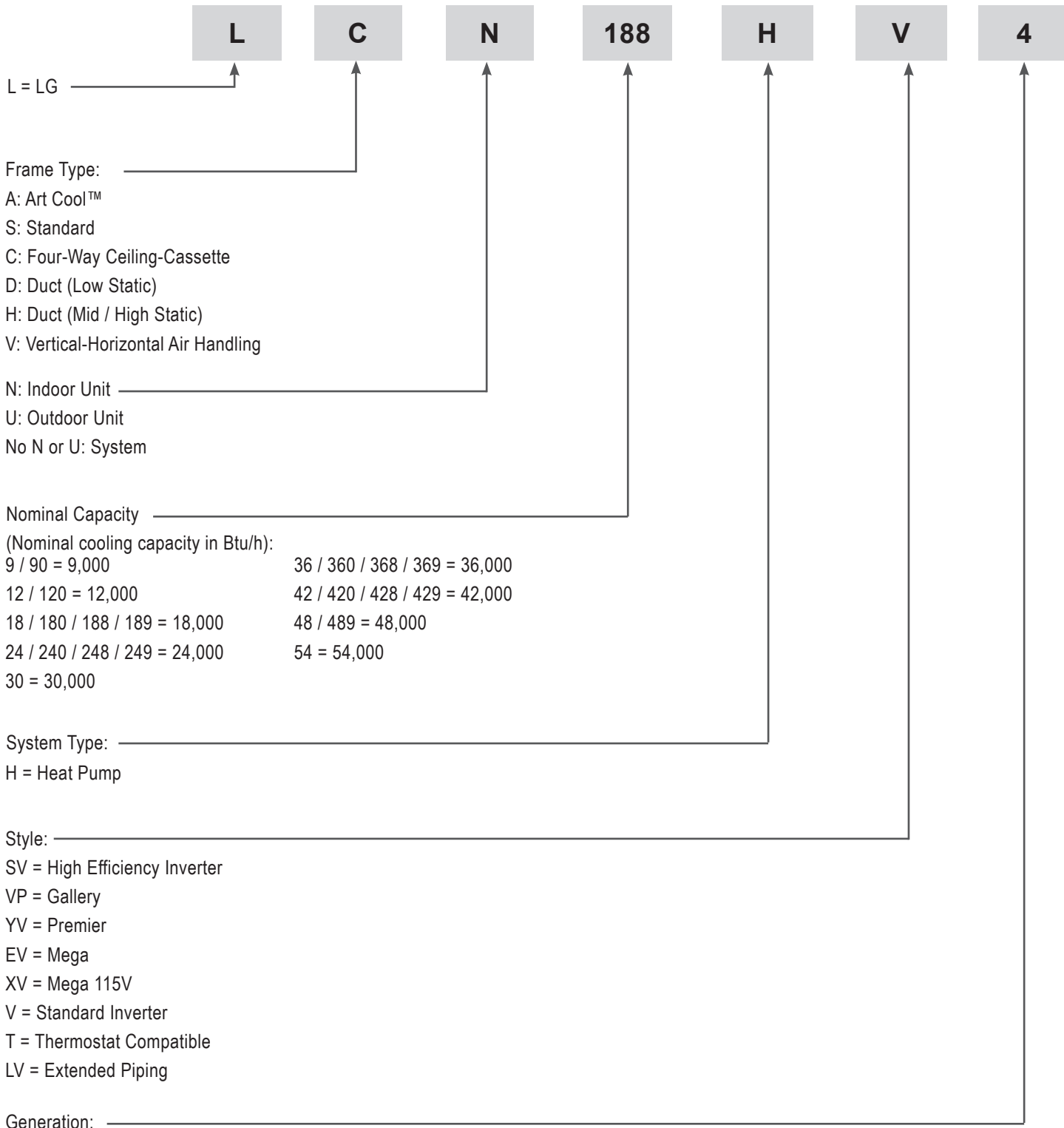





Single Zone Four-Way Ceiling-Cassette Installation Manual

Required Parts (field provided)

- Connecting cable (power and control)
- Pipes - vapor line and liquid line, with insulation
- 3/8" or 1/2" Threaded hanger rods
- 3/8" or 1/2" nuts, flat washers, and lock/split washers
- Additional drain hose
- Insulation for additional drain hose

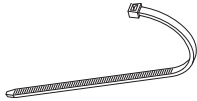
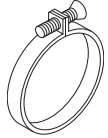
Included Parts

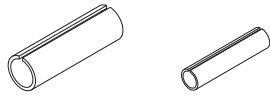
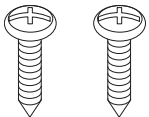
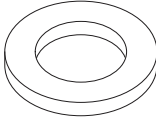
Table 1: Included Items.

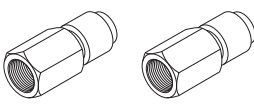
Part	Quantity	Image	Part	Quantity	Image
Drain Hose	One (1)		Cable Ties	Four (4)	
Metal Clamp	Two (2)		Conduit Bracket	One (1)	
Insulation for Fittings	One (1) Set	 For Vapor Piping For Liquid Piping	M4 Screws	Two (2)	
Washers for Hanging Bracket	Eight (8)		Wireless Handheld Controller with Holder (AKB73757604 [2x2] or AKB75735404 [3x3]) ¹	One (1)	
Connectors (included only for single-zone system installations)	One (1) Each for Ø3/8 inch → Ø1/2 inch One (1) Each for Ø5/8 inch → Ø1/2 inch One (1) Each for Ø1/4 inch → Ø3/8 inch				

¹Wireless Handheld Controller for the four-way ceiling-cassette indoor units is also referenced by Model No. PQWRHQ0FDB.

Table 2: Required Accessory Table.

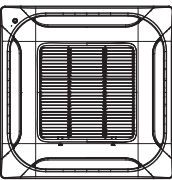
Part	Quantity	Image
Four-Way Ceiling Cassette Grille Kit (PT-QAGW0 / PT-QCHW0 [2x2]; PT-AAGW0 or PT-AFGW0 [3x3])	One (1)	

GENERAL DATA

Four-Way Ceiling-Cassette Specifications

Table 3: Four-Way 2 x 2 Ceiling Cassette System General Data.

System (Model) (Indoor Unit / Outdoor Unit)	LC098HV (LCN098HV4 / LUU090HV)	LC128HV (LCN128HV4 / LUU120HV)	LC188HV (LCN188HV4 / LUU180HV)
Ceiling Grille Model Number (Sold Separately)	PT-QAGW0 / PT-QCHW0	PT-QAGW0 / PT-QCHW0	PT-QAGW0 / PT-QCHW0
Cooling Capacity (Min/Rated/Max) (Btu/h)	3,600 ~ 9,000 ~ 9,900	3,400 ~ 11,100 ~ 12,400	7,700 ~ 18,000 ~ 24,800
Cooling Power Input¹ (Min/Rated/Max) (kW)	0.19 ~ 0.66 ~ 0.83	0.25 ~ 0.88 ~ 1.1	0.54 ~ 1.44 ~ 2.60
EER2 (@95°F)	13.65	12.6	12.5
SEER2	20.2	19.4	20.5
Heating Capacity (Min/Rated/Max) (Btu/h)	4,400 ~ 11,000 ~ 12,100	2,800 ~ 14,000 ~ 15,500	6,500 ~ 18,500 ~ 23,400
Heating Power Input¹ (Min/Rated/Max) (kW)	0.15 ~ 0.83 ~ 1.05	0.22 ~ 1.19 ~ 1.5	0.50 ~ 1.95 ~ 2.60
COP (@47°F)	3.88	3.44	2.78
HSPF2	10.55	10.35	9.70
Rated Low Heating Capacity (Btu/h)			
Outdoor 17°F (WB)/Indoor 70°F (DB)	7,000	9,100	12,700
Low COP (@17°F)	2.92	2.7	2.45
Maximum Heating Capacity (Btu/h)			
Outdoor 17°F (DB)/Indoor 70°F (DB)	11,000	11,900	17,000
Outdoor 5°F (DB)/Indoor 70°F (DB)	10,100	10,700	16,200
Outdoor -4°F (DB)/Indoor 70°F (DB)	9,040	9,280	15,250
ENERGY STAR 6.1 / Cold Climate	Yes / Yes	Yes / Yes	Yes / Yes
Power Supply V, Ø, Hz²	208-230 / 1 / 60		
Power Wiring / Communications Cable (No. x AWG)²	4 x 14	4 x 14	4 x 14
Outdoor Unit Operating Range			
Cooling (°F DB)	0 to +118 ⁶		5 to +118 ⁶
Heating (°F WB)	-4 to +64		
Indoor Unit Operating Range			
Cooling (°F WB)	57 to 77		
Heating (°F DB)	59 to 81		
Indoor Temperature Setting Range			
Cooling (°F DB)	65 to 86		
Heating (°F DB)	61 to 86		
Unit Data			
Refrigerant Type³ / Refrigerant Control	R410A / EEV		
IDU Sound Pressure Level ±1 dB(A) (H/M/L)⁴	36 / 33 / 30	38 / 35 / 32	43 / 41 / 38
ODU Sound Pressure Level ±1 dB(A) (Max.) (Cool/Heat)⁴	47 / 51	49 / 52	48 / 52
ODU External Static Pressure	0.1	0.1	0.1
IDU Dimensions (W x H x D) (in.)	22-7/16 x 8-7/64 x 22-7/16		22-7/16 x 10-5/64 x 22-7/16
ODU Dimensions (W x H x D) (in.)	30-5/16 x 21-15/32 x 11-11/32		37-13/32 x 32-27/32 x 13.0
IDU Net / Shipping Weight (lbs.)	31 / 37	31 / 37	32 / 40
ODU Net / Shipping Weight (lbs.)	71 / 76	71 / 76	130.1 / 147.7
Grille Net / Shipping Weight (lbs.)	7 / 9	7 / 9	7 / 9

EEV: Electronic Expansion Valve, IDU: Indoor Unit, ODU: Outdoor Unit. Unit comes with a dry helium charge. This data is rated 0 ft above sea level, with 24.6 ft of refrigerant line per indoor unit and a 0 ft level difference between outdoor and indoor units.

Cooling capacity rating obtained with air entering the indoor coil at 80°F dry bulb (DB) and 67°F wet bulb (WB); and outdoor ambient conditions of 95°F dry bulb (DB) and 75°F wet bulb (WB).

Heating capacity rating obtained with air entering the indoor unit at 70°F dry bulb (DB) and 60°F wet bulb (WB); and outdoor ambient conditions of 47°F dry bulb (DB) and 43°F wet bulb (WB).

¹Power Input is rated at high speed.

²All power wiring/communication cables from ODU to IDU are field supplied and are to be minimum 14

AWG, 4-conductor, stranded, shielded or unshielded (if shielded, must be grounded to chassis at ODU only), and must comply with applicable local and national codes.

³Take appropriate actions at the end of HVAC equipment life to recover, recycle, reclaim or destroy R410A refrigerant according to applicable regulations (40 CFR Part 82, Subpart F) under section 608 of CAA.

⁴Sound pressure levels are tested in an anechoic chamber under ISO Standard 3745.

⁵Piping lengths are equivalent.

⁶Cooling range can be extended from 0°F or 5°F down to -4°F using the Low Ambient Wind Baffle Kit (sold separately).

GENERAL DATA

Table 4: Four-Way 2 x 2 Ceiling Cassette System General Data (continued).

Compressor (Type x Qty.)	Twin Rotary x 1	Twin Rotary x 1	Twin Rotary x 1
Dehumidification Rate (pts./hr.)	1.6	2.47	3.3
Heat Exchanger			
Material and Fin Coating	Copper Tube / Aluminum Fin and Gold Fin™ Coated / Hydrophilic		
Rows / Columns / Fin per inch x Qty.	(2 x 24 x 14) x 1	(2 x 24 x 14) x 1	(2 x 38 x 14) x 1
Fan			
Indoor Unit Type x Qty.	Turbo x 1		
Outdoor Unit Type x Qty.	Axial x 1		
Outdoor Unit Motor Output (W) x Qty.	43 x 1	43 x 1	124 x 1
Outdoor Unit Motor / Drive	Brushless Digitally Controlled / Direct		
Airflow Rate			
Indoor Unit (H / M / L [CFM])	300 / 265 / 230	335 / 283 / 247	459 / 424 / 388
Outdoor Unit (Maximum) (CFM)	988	988	2,048
Piping			
Liquid (in.)	Connection / Pipe Size	1/4 / 1/4	1/4 / 3/8
Vapor (in.)	Connection / Pipe Size	3/8 / 3/8	1/2 / 5/8
Indoor Unit Condensate Drain O.D. / I.D. (in.)		1-1/4 / 1	1-1/4 / 1
Refrigerant Pre-Charge (oz.)		38.8	70.56
Additional Refrigerant Charge (oz./ft.)		0.22	0.43
Pipe Length (Minimum / Maximum) (ft.)		16.4 / 66	16.4 / 164
Piping Length⁵ (no additional refrigerant, ft.)		24.6	24.6
Maximum Elevation Difference (ft.)		49	98.4

EEV: Electronic Expansion Valve; IDU: Indoor Unit; ODU: Outdoor Unit. Unit comes with a dry helium charge. This data is rated 0 ft above sea level, with 24.6 ft of refrigerant line per indoor unit and a 0 ft level difference between outdoor and indoor units.

Cooling capacity rating obtained with air entering the indoor coil at 80°F dry bulb (DB) and 67°F wet bulb (WB); and outdoor ambient conditions of 95°F dry bulb (DB) and 75°F wet bulb (WB). Heating capacity rating obtained with air entering the indoor unit at 70°F dry bulb (DB) and 60°F wet bulb (WB); and outdoor ambient conditions of 47°F dry bulb (DB) and 43°F wet bulb (WB).

¹Power Input is rated at high speed.

²All power wiring/communication cables from ODU to IDU are field supplied and are to be minimum 14

AWG, 4-conductor, stranded, shielded or unshielded (if shielded, must be grounded to chassis at ODU only), and must comply with applicable local and national codes.

³Take appropriate actions at the end of HVAC equipment life to recover, recycle, reclaim or destroy R410A refrigerant according to applicable regulations (40 CFR Part 82, Subpart F) under section 608 of CAA.

⁴Sound pressure levels are tested in an anechoic chamber under ISO Standard 3745.

⁵Piping lengths are equivalent.

⁶Cooling range can be extended from 0°F or 5°F down to -4°F using the Low Ambient Wind Baffle Kit (sold separately).

GENERAL DATA

Four-Way Ceiling-Cassette Specifications

Table 5: Four-Way 3 x 3 Ceiling Cassette System General Data.

System (Model) (Indoor Unit / Outdoor Unit)	LC249HV (LCN249HV / LUU240HV)	LC369HV (LCN369HV / LUU360HV)	LC429HV (LCN429HV / LUU420HV)
Ceiling Grille Model Number (Sold Separately)	PT-AAGW0	PT-AAGW0	PT-AAGW0
Cooling Capacity (Min/Rated/Max) (Btu/h)	9,600~23,000~28,000	14,400~36,000~42,000	16,800~42,000~48,700
Cooling Power Input ¹ (Min/Rated/Max) (kW)	0.48 ~ 1.96 ~ 3.04	0.72 ~ 2.88 ~ 3.90	1.16 ~ 4.01 ~ 5.5
EER2 (@95°F)	11.70	12.50	10.45
SEER2	20.0	21.0	19.3
Heating Capacity (Min/Rated/Max) (Btu/h)	10,800~27,000~30,000	16,000~40,000~42,200	18,800~47,000~49,800
Heating Power Input ¹ (Min/Rated/Max) (kW)	0.58 ~ 2.25 ~ 3.20	0.80 ~ 3.26 ~ 4.20	1.17 ~ 3.63 ~ 4.93
COP (@47°F)	3.51	3.60	3.79
HSPF2	10.2	10.0	10.05
Rated Low Heating Capacity (Btu/h)			
Outdoor 17°F (WB)/Indoor 70°F (DB)	17,400	24,000	28,000
Low COP (@17°F)	2.68	2.69	2.95
Maximum Heating Capacity (Btu/h)			
Outdoor 17°F (DB)/Indoor 70°F (DB)	26,000	38,000	41,500
Outdoor 5°F (DB)/Indoor 70°F (DB)	21,200	35,000	39,000
Low COP (OD 5°F)	2.07	2.10	1.96
Outdoor -4°F (DB)/Indoor 70°F (DB)	20,760	31,450	38,230
ENERGY STAR 6.1 / Cold Climate	Yes / Yes	Yes / Yes	No / Yes
Power Supply V, Ø, Hz ²	208-230 / 1 / 60		
Power Wiring / Comm. Cable (No. x AWG) ²	4 x 14	4 x 14	4 x 14
Outdoor Unit Operating Range			
Cooling (°F DB)	5 to +118 ⁶		
Heating (°F WB)	-4 to +64		
Indoor Unit Operating Range			
Cooling (°F WB)	57 to 77		
Heating (°F DB)	59 to 81		
Indoor Temperature Setting Range			
Cooling (°F DB)	65 to 86		
Heating (°F DB)	61 to 86		
Unit Data			
Refrigerant Type ³ / Refrigerant Control	R410A / EEV		
IDU Sound Pressure Level ±1 dB(A) (Mx/H/M/L/SL) ⁴	48 / 40 / 37 / 35 / 32	55 / 44 / 42 / 41 / 40	56 / 46 / 43 / 41 / 39
ODU Sound Pressure Level ±1 dB(A) (Max.) (Cool/Heat) ⁴	48 / 52	52 / 54	52 / 54
ODU External Static Pressure	0.1	0.1	0.1
IDU Dimensions (W x H x D) (in.)	33-1/16 x 8-1/32 x 33-1/16		
ODU Dimensions (W x H x D) (in.)	37-13/32 x 32-27/32 x 13.0	37-13/32 x 54-11/32 x 13.0	37-13/32 x 54-11/32 x 13.0
Indoor Unit Net / Shipping Weight (lbs.)	45.9 / 54.9	56.4 / 67.7	60.2 / 70.5
Outdoor Unit Net / Shipping Weight (lbs.)	130.1 / 147.7	193.1 / 217.4	193.1 / 217.4
Grille Net / Shipping Weight (lbs.)	15.6 / 20.5	15.6 / 20.5	15.6 / 20.5

EEV: Electronic Expansion Valve, IDU: Indoor Unit, ODU: Outdoor Unit. Unit comes with a dry helium charge. This data is rated 0 ft above sea level, with 24.6 ft of refrigerant line per indoor unit and a 0 ft level difference between outdoor and indoor units.

Cooling capacity rating obtained with air entering the indoor coil at 80°F dry bulb (DB) and 67°F wet bulb (WB); and outdoor ambient conditions of 95°F dry bulb (DB) and 75°F wet bulb (WB). Heating capacity rating obtained with air entering the indoor unit at 70°F dry bulb (DB) and 60°F wet bulb (WB); and outdoor ambient conditions of 47°F dry bulb (DB) and 43°F wet bulb (WB).
¹Power Input is rated at high speed.
²All power wiring/communication cables from ODU to IDU are field supplied and are to be minimum 14

AWG, 4-conductor, stranded, shielded or unshielded (if shielded, must be grounded to chassis at ODU only), and must comply with applicable local and national codes.

³Take appropriate actions at the end of HVAC equipment life to recover, recycle, reclaim or destroy R410A refrigerant according to applicable regulations (40 CFR Part 82, Subpart F) under section 608 of CAA.

⁴Sound pressure levels are tested in an anechoic chamber under ISO Standard 3745.

⁵Piping lengths are equivalent.

⁶Cooling range can be extended from 5°F down to -4°F using the Low Ambient Wind Baffle Kit (sold separately).

GENERAL DATA

Table 6: Four-Way 3 x 3 Ceiling Cassette System General Data (continued).

Compressor (Type x Qty.)		Twin Rotary x 1	Scroll x 1	Scroll x 1
Dehumidification Rate (pts./hr.)		4.5	7.6	10.1
Heat Exchanger				
Material and Fin Coating		Copper Tube / Aluminum Fin and Gold Fin™ Coated / Hydrophilic		
Rows / Columns / Fin per inch x Qty.		(2 x 38 x 14) x 1	(2 x 32 x 14) x 1	(2 x 32 x 14) x 1
Fan				
Indoor Unit Type x Qty.		Turbo x 1	Turbo x 1	
Outdoor Unit Type x Qty.		Axial x 1	Axial x 2	
Outdoor Unit Motor Output (W) x Qty.		124 x 1	124 x 2	124 x 2
Motor / Drive		Brushless Digitally Controlled / Direct		
Airflow Rate				
Indoor Unit (Max / H / M / L [CFM])		794 / 671 / 600 / 530	1,200 / 971 / 883 / 794	1,483 / 1,130 / 953 / 812
Outdoor Unit (Maximum) (CFM)		2,048	2 x 1,942	2 x 1,942
Piping				
Liquid (in.)	Connection / Pipe Size	3/8 / 3/8	3/8 / 3/8	3/8 / 3/8
Vapor (in.)	Connection / Pipe Size	5/8 / 5/8	5/8 / 5/8	5/8 / 5/8
Indoor Unit Condensate Drain O.D. / I.D. (in.)		1-1/4 / 1		
Refrigerant Pre-Charge (oz.)		70.56	120.00	120.00
Additional Refrigerant Charge (oz./ft.)		0.43		
Pipe Length (Minimum / Maximum) (ft.)		16.4 / 164	16.4 / 246	
Piping Length⁵ (no additional refrigerant, ft.)		24.6		
Maximum Elevation Difference (ft.)		98.4		

EEV: Electronic Expansion Valve, IDU: Indoor Unit, ODU: Outdoor Unit. Unit comes with a dry helium charge. This data is rated 0 ft above sea level, with 24.6 ft of refrigerant line per indoor unit and a 0 ft level difference between outdoor and indoor units.

Cooling capacity rating obtained with air entering the indoor coil at 80°F dry bulb (DB) and 67°F wet bulb (WB); and outdoor ambient conditions of 95°F dry bulb (DB) and 75°F wet bulb (WB). Heating capacity rating obtained with air entering the indoor unit at 70°F dry bulb (DB) and 60°F wet bulb (WB); and outdoor ambient conditions of 47°F dry bulb (DB) and 43°F wet bulb (WB).

¹Power Input is rated at high speed.

²All power wiring/communication cables from ODU to IDU are field supplied and are to be minimum 14

AWG, 4-conductor, stranded, shielded or unshielded (if shielded, must be grounded to chassis at ODU only), and must comply with applicable local and national codes.

³Take appropriate actions at the end of HVAC equipment life to recover, recycle, reclaim or destroy R410A refrigerant according to applicable regulations (40 CFR Part 82, Subpart F) under section 608 of CAA.

⁴Sound pressure levels are tested in an anechoic chamber under ISO Standard 3745.

⁵Piping lengths are equivalent.

⁶Cooling range can be extended from 5°F down to -4°F using the Low Ambient Wind Baffle Kit (sold separately).

GENERAL DATA

Electrical

Table 7: Electrical Data.

Nominal Tons	Unit Model No.	Hertz	Voltage	Voltage Range (Min. to Max.)	MCA	MOP	Compressor Quantity	Compressor Motor RLA (Cooling)	Condenser Fan Motor(s)	
									Condenser Fan Quantity.	Condenser Fan Motor FLA
2 x 2 Four-Way Ceiling Cassettes										
3/4	LUU090HV	60	208 - 230	187 - 253	11.9	15	1	9.0	1	0.2
1	LUU120HV				12.3					
1-1/2	LUU180HV				20	30		13.5		
3 x 3 Four-Way Ceiling Cassettes										
2	LUU240HV	60	208 - 230	187 - 253	20	30	1	13.5	1	1.6
3	LUU360HV				32	40		22	2	1.6 x 2
3-1/2	LUU420HV									

Voltage tolerance is $\pm 10\%$.

Maximum allowable voltage unbalance is 2%.

RLA = Rated Load Amps.

MCA = Minimum Circuit Ampacity.



Maximum Overcurrent Protection (MOP) is calculated as follows: (Largest motor FLA x 2.25) + (Sum of other motor FLA) rounded down to the nearest standard fuse size.

GENERAL INSTALLATION GUIDELINES

Outdoor Unit Location Selection

Selecting the Best Location for the Outdoor Unit

⚠ DANGER

-  Do not install the unit in an area where combustible gas will generate, flow, stagnate, or leak. These conditions can cause a fire, resulting in bodily injury or death.
-  Do not install the unit in a location where acidic solution and spray (sulfur) are often used as it can cause bodily injury or death.
-  Do not use the unit in environments where oil, steam, or sulfuric gas are present as it can cause bodily injury or death.

⚠ CAUTION

When deciding on a location to place the outdoor unit, be sure to choose an area where run-off from defrost will not accumulate and freeze on sidewalks or driveways, which will create unsafe conditions. Properly install and insulate any drain hoses to prevent the hose from freezing, cracking, leaking, and causing unsafe conditions from frozen condensate.

⚠ WARNING

Install a fence to prevent vermin from crawling into the unit or unauthorized individuals from accessing it. Vermin and unauthorized individuals will cause a fire, electric shock, physical injury or death. Follow the placement guidelines set forth in "Clearance Requirements".

⚠ NOTE

Install a fence to prevent vermin from crawling into the unit or unauthorized individuals from accessing it. Vermin and unauthorized individuals will damage the unit. Follow the placement guidelines set forth in "Clearance Requirements".

Select a location for installing the outdoor unit that will meet the following conditions:

- Where there is enough strength to bear the weight of the unit.
- A location that allows for optimum air flow and is easily accessible for inspection, maintenance, and service.
- Where piping between the outdoor unit and indoor unit is within allowable limits.
- Include space for drainage to ensure condensate flows properly out of the unit when it is in heating mode.  Avoid placing the outdoor unit in a low-lying area where water could accumulate.
- If the outdoor unit is installed in a highly humid environment (near an ocean, lake, etc.), ensure that the site is well-ventilated and has a lot of natural light (Example: Install on a rooftop).

Do Not's

- Where it will be subjected to direct thermal radiation from other heat sources, or an area that would expose the outdoor unit to heat or steam like discharge from boiler stacks, chimneys, steam relief ports, other air conditioning units, kitchen vents, plumbing vents, and other sources of extreme temperatures.
- Where high-frequency electrical noise / electromagnetic waves will affect operation.
- Where operating sound from the unit will disturb inhabitants of surrounding buildings.
- Where the unit will be exposed to direct, strong winds.
- Where the discharge of one outdoor unit will blow into the inlet side of an adjacent unit (when installing multiple outdoor units).

Planning for Snow and Ice

To ensure the outdoor unit operates properly, certain measures are required in locations where there is a possibility of heavy snowfall or severe windchill or cold:

1. Prepare for severe winter wind chills and heavy snowfall, even in areas of the country where these are unusual phenomena.
2. Position the outdoor unit so that its airflow fans are not buried by direct, heavy snowfall. If snow piles up and blocks the airflow, the system will malfunction.
3. Remove any snow that has accumulated four (4) inches or more on the top of the outdoor unit.
4. In climates that will experience significant snow buildup, mount the outdoor unit on a raised, field-provided platform or stand. The raised support platform must be high enough to allow the unit to remain above possible snow drifts, and must be higher than the maximum anticipated snowfall for the location.
5. Design the mounting base to prevent snow accumulation on the platform in front or back of the unit frame.
6. Provide a field fabricated snow protection hood to keep snow and ice and/or drifting snow from accumulating on the coil surfaces.
7. To prevent snow and heavy rain from entering the outdoor unit, install the condenser air inlets and outlets facing away from direct winds.
8. Consider tie-down requirements in case of high winds or where required by local codes.

GENERAL INSTALLATION GUIDELINES

Outdoor Unit Location Selection

Planning for Snow and Ice, continued.

⚠ CAUTION

When deciding on a location to place the outdoor unit, be sure to choose an area where run-off from defrost cycle will not accumulate and freeze on sidewalks or driveways, which will create unsafe conditions. Properly install and insulate any drain hoses to prevent the hose from freezing, cracking, leaking, and causing unsafe conditions from frozen condensate.

⚠ NOTE

Choose an area where run-off water from defrost cycle will not accumulate and freeze on sidewalks or driveways. Properly install and insulate any drain hoses to prevent the hose from freezing, cracking, leaking, and damaging the outdoor unit.

Note:

The indoor unit will take longer to provide heat, or heating performance will be reduced in winter if the unit is installed:

1. In a narrow, shady location.
2. Near a location that has a lot of ground moisture.
3. In a highly humid environment.
4. In an area in which condensate does not drain properly.

Tie-Downs and Lightning Protection

Tie-Downs

- The strength of the roof must be checked before installing the outdoor units.
- If the installation site is prone to high winds or earthquakes, when installing on the wall or roof, securely anchor the mounting base using a field-provided tie-down configuration approved by a local professional engineer.
- The overall tie-down configuration must be approved by a local professional engineer.

Note:

Always refer to local code when using a wind restraint system.

Lightning Protection

- To protect the outdoor unit from lightning, it must be placed within the specified lightning safety zone.

Table 8: Safety Zone Specifications.

Building Height (feet)	66	98	148	197
Protection Angle (°)	55	45	35	25

- Power cable and communication cable must be installed five (5) feet away from lightning rod.
- A high-resistance ground system must be included to protect against induced lightning or indirect strike.

⚠ NOTE

If the building does not include lightning protection, the outdoor unit will be damaged from a lightning strike. Inform the customer of this possibility in advance.

Figure 1: Lightning Protection Diagram.

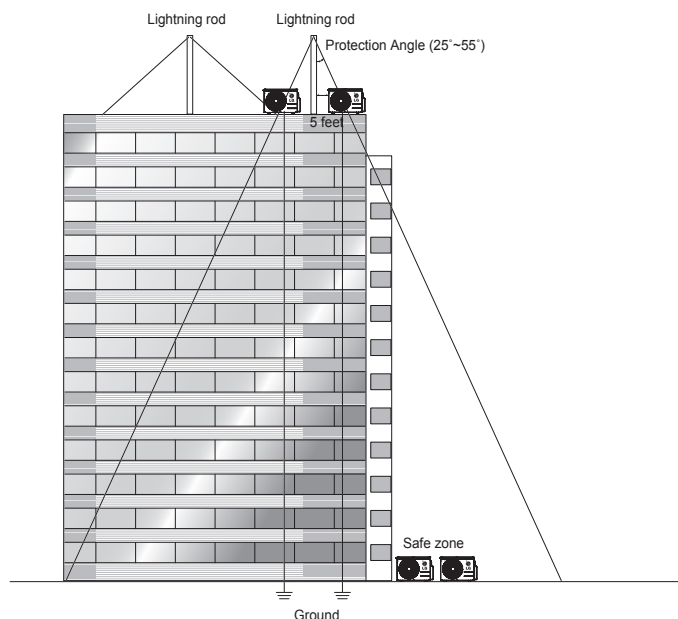

GENERAL INSTALLATION GUIDELINES

Outdoor Unit Location Selection

Oceanside Applications

Use of a Windbreak to Shield from Sea Wind

Note:

Ocean winds will cause corrosion, particularly on the condenser and evaporator fins, which, in turn could cause product malfunction or inefficient performance.

- ⚠️ Avoid installing the outdoor unit where it would be directly exposed to ocean winds.
- Install the outdoor unit on the side of the building opposite from direct ocean winds.
- Select a location with good drainage.
- Periodically clean dust or salt particles off of the heat exchanger with water.
- If the outdoor unit must be placed in a location where it would be subjected to direct ocean winds, install a concrete windbreak strong enough to block any winds.
- Windbreak must be more than 150% of the outdoor unit's height. There must be 2 to 3-1/2 inches of clearance between the outdoor unit and the windbreaker for purposes of air flow.

Note:

Additional anti-corrosion treatment will need to be applied to the outdoor unit at oceanside locations.

Use of a Building to Shield from Sea Wind

If a windbreak is not possible, a building or larger structure must be used to shield the outdoor unit from direct exposure to the sea wind. The unit must be placed on the side of the building directly opposite to the direction of the wind as shown in the figure at right.

Figure 2: Oceanside Placement Using Windbreak.

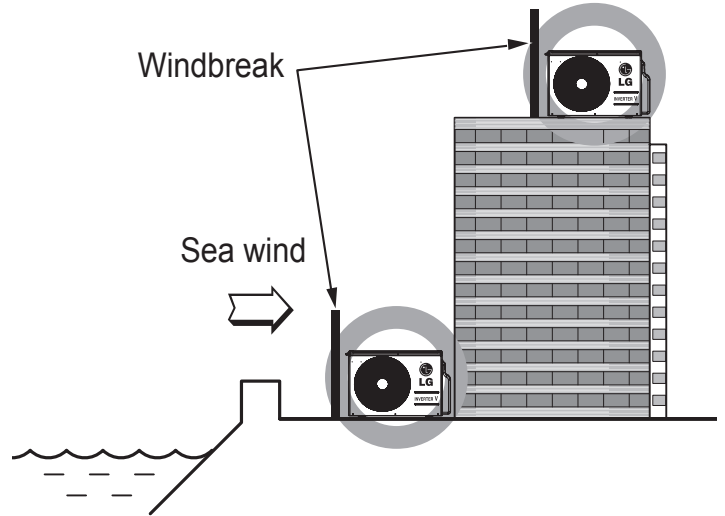
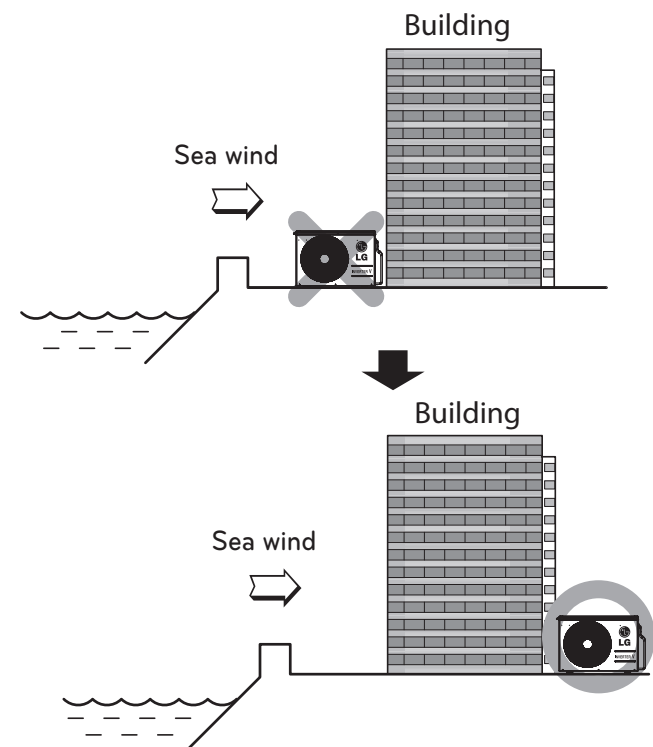

Figure 3: Placement Using Building as Shield.



GENERAL INSTALLATION GUIDELINES

Required Outdoor Unit Clearances

Minimum Allowable Clearance and Service Access Requirements

Proper clearance for the outdoor unit coil is critical for proper unit operation. When installing the outdoor unit, consider service, inlet and outlet, and minimum allowable space requirements as illustrated in the diagrams below and on the following pages.

- Include enough space for airflow and for service access. If installing multiple outdoor units, ⚠ avoid placing the units where the discharge of one unit will blow into the inlet side of an adjacent unit.
- If an awning is built over the unit to prevent direct sunlight or rain exposure, make sure that the discharge air of the outdoor unit isn't restricted.
- ⚠ No obstacles to air circulation around the unit; keep proper distances from ceilings, fences, floor, walls, etc. (Install a fence to prevent pests from damaging the unit or unauthorized individuals from accessing it.)

Outdoor Unit (9,000 to 24,000 Capacity) Service Access and Allowable Clearances

Specific clearance requirements in the diagram below are for (9,000 to 24,000 Btu/h capacities). The figure below shows the overall minimum clearances that must be observed for safe operation and adequate airflow around the outdoor unit.

When placing the outdoor unit under an overhang, awning, sunroof or other "roof-like structure", observe the clearance requirements (as shown in Cases 1 and 2) for height in relation to the unit. To have successful service access to the outdoor unit, see the figure below for minimum spacing. When installing multiple outdoor units, see Cases 4 and 5 for correct spacing requirements.

Note:

If the outdoor unit is installed between standard and minimum clearances, capacity decreases approximately 10%.

Figure 4: 9,000 to 24,000 Capacity Outdoor Unit Service Access and Allowable Clearances Diagram.

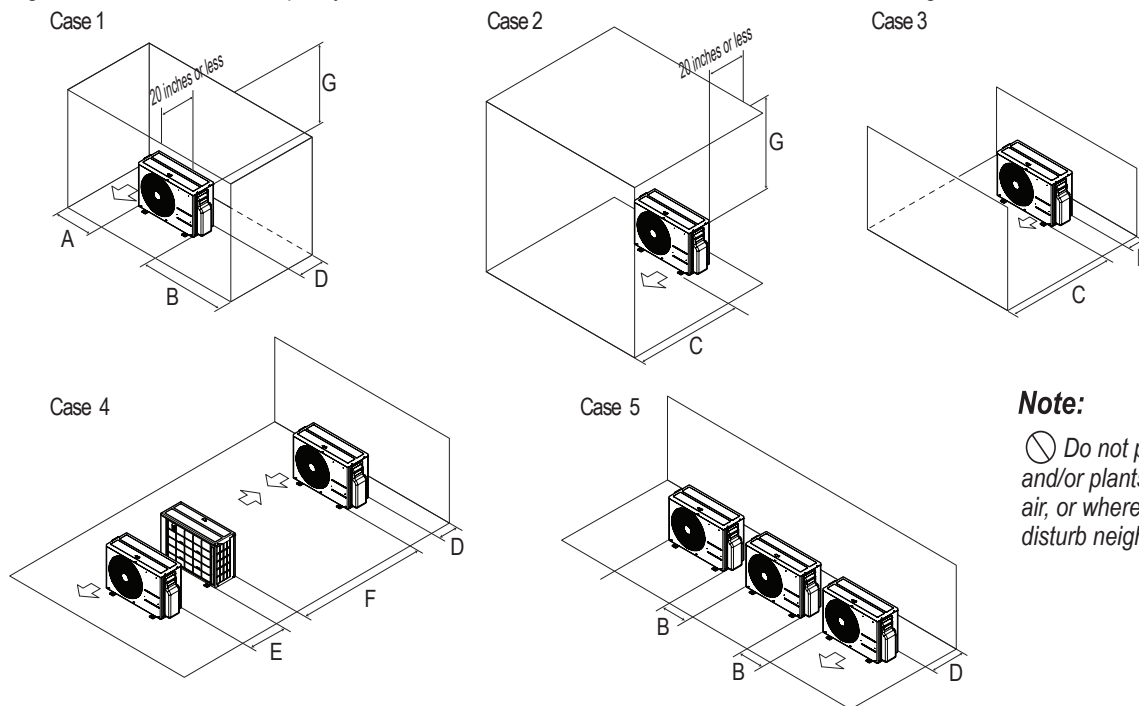

Note:

⚠ Do not place the unit where animals and/or plants will be in the path of the warm air, or where the warm air and/or noise will disturb neighbors.

Table 9: 9,000 to 24,000 Outdoor Unit Service Access and Allowable Clearances Diagram Legend.

Unit: Inch		A	B	C	D	E	F	G
Case 1	Standard	12	24	-	12	-	-	-
	Minimum	4	10	-	4	-	-	40
Case 2	Standard	-	-	20	-	-	-	-
	Minimum	-	-	14	-	-	-	40
Case 3	Standard	-	-	20	12	-	-	-
	Minimum	-	-	14	4	-	-	-
Case 4	Standard	-	-	-	12	24	-	-
	Minimum	-	-	-	4	8	79	-
Case 5	Standard	-	24	-	12	-	-	-
	Minimum	-	10	-	4	-	-	-

GENERAL INSTALLATION GUIDELINES

Required Outdoor Unit Clearances

Outdoor Unit (36,000 and 42,000 Btu/h Capacity) Service Access and Allowable Clearances

When installing the outdoor unit, consider service, inlet, and outlet, and minimum allowable space requirements as illustrated in the following diagrams.

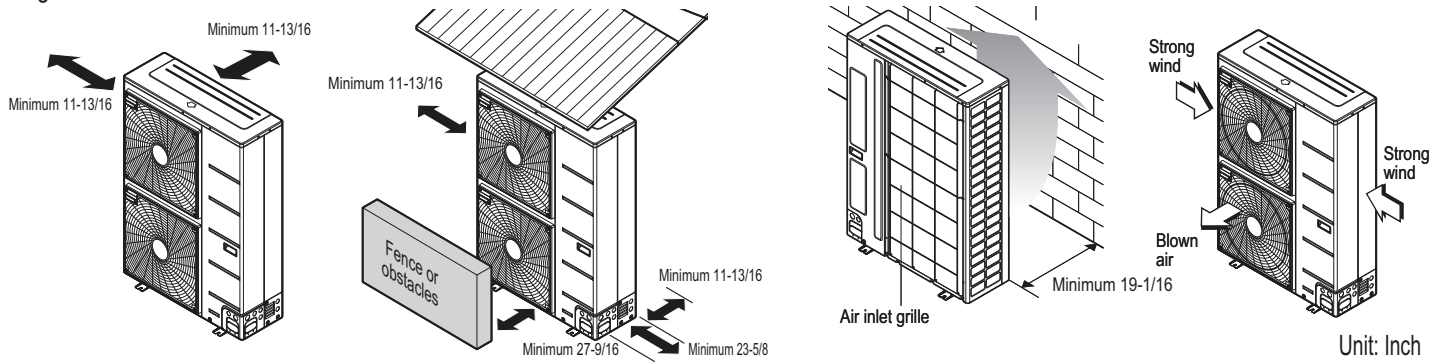

Ensure that the space at the back of the outdoor unit is a minimum of 11-13/16 inches, and include a minimum of 23-5/8 inches at the right side of the unit for service.

If the outdoor unit discharge side faces a wall, include a minimum of 19-11/16 inches between the outdoor unit and the wall. Install the outdoor unit so that the discharge port is set at a right angle to the wind direction.

Clearance Requirements when Different Obstacles are Present (Unit: Inch).

Obstacle on the suction side only.

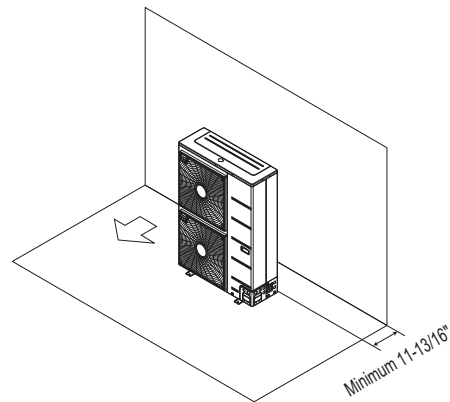

Obstacles on the suction side and on both left and right sides.

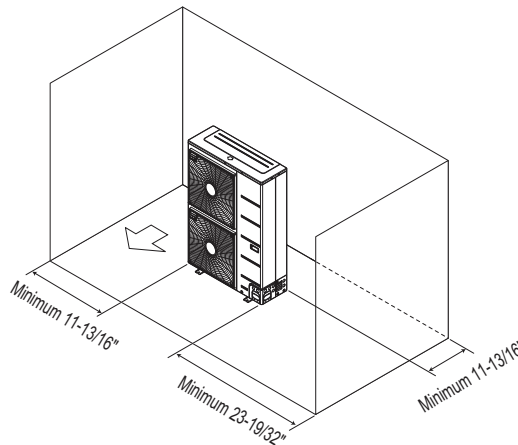

Obstacles above and on the air intake side.

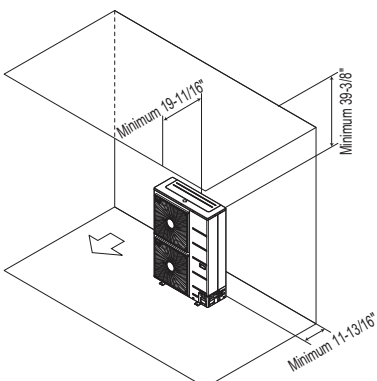

Obstacles above, on the air intake side, and on both left and right sides

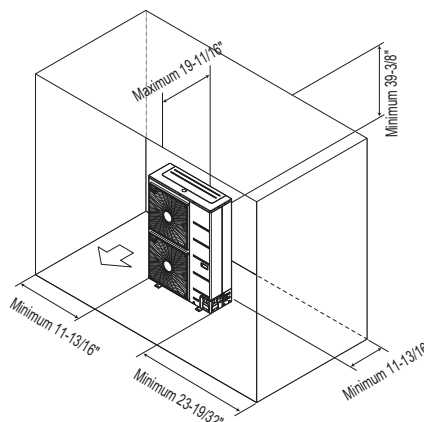

GENERAL INSTALLATION GUIDELINES

Required Outdoor Unit Clearances

Obstacle just on the air discharge side.

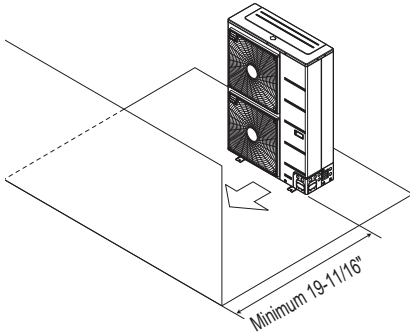

Obstacles above and on the air discharge side.

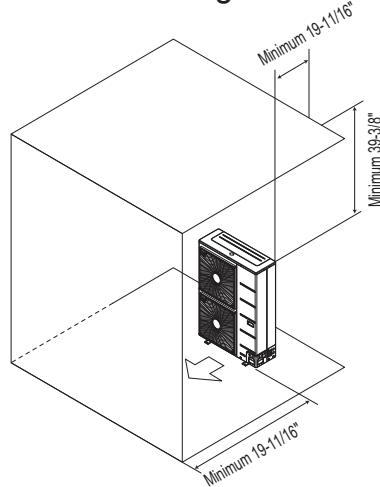

Where there are obstacles on both suction and discharge sides (discharge side obstacle is higher than the outdoor unit).

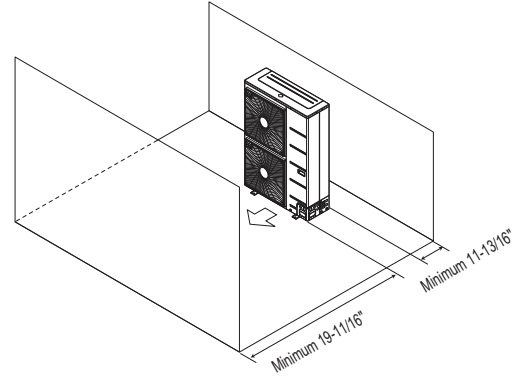

Where there are obstacles above, and on both suction and discharge sides (discharge side obstacle is higher than the outdoor unit).

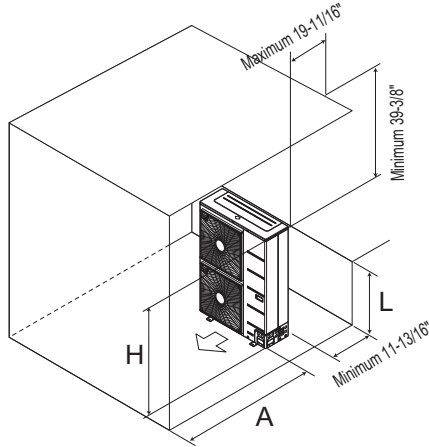
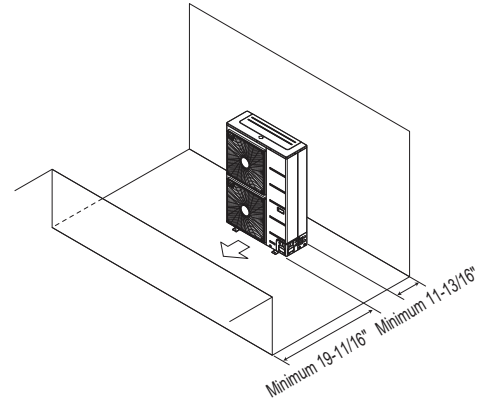

Table 10: Ratio among H, A, and L.

	L	A
L ≤ H	0 < L ≤ 1/2 H	29-1/32 inches
	1/2 H < L	39-3/8 inches
H < L	Set Stand as: L ≤ H	

If a stand is necessary, it should be contained (not open frame) to prevent the discharge air from short cycling.

Where there are obstacles on both suction and discharge sides (discharge side obstacle is lower than the outdoor unit).



Where there are obstacles above, and on both suction and discharge sides (discharge side obstacle is lower than the outdoor unit).

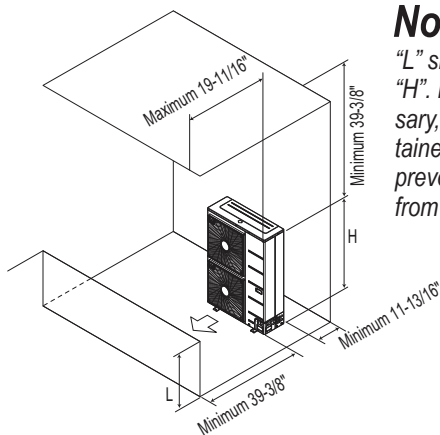

Note:

"L" should be lower than "H". If a stand is necessary, it should be contained (not open frame) to prevent the discharge air from short cycling.

Series installation

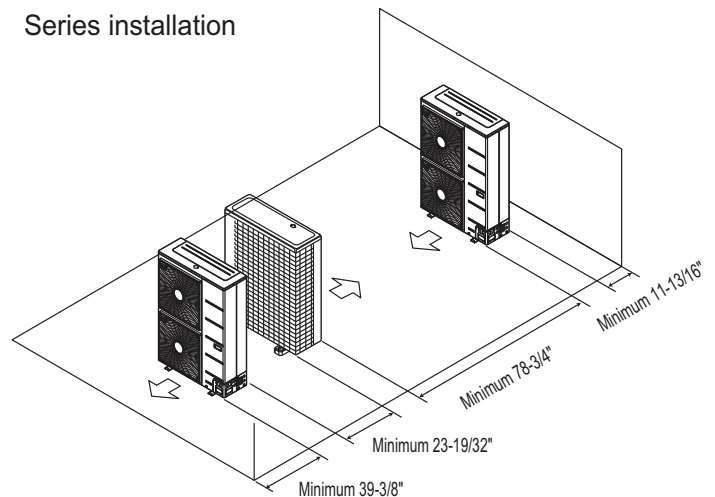

GENERAL INSTALLATION GUIDELINES

Rigging and Lifting / Outdoor Unit Mounting

Rigging and Lifting Instructions

⚠ WARNING

Wear protective gloves and safety goggles when handling equipment. Sharp edges will cause personal injury.

Dispose of the packing materials safely.

- Packing materials, such as nails and other metal or wooden parts, will cause puncture wounds or other injuries.
- Remove the wood pallet from the bottom of the outdoor unit drain pan before installing it to the platform / bracket / etc. An unstable installation will cause the outdoor unit to fall, resulting in physical injury and / or death. Also, brazing around a wood pallet will result in a fire, causing physical injury and / or death.
- Tear apart and throw away plastic packaging bags so that children do not play with them and risk suffocation and death.

⚠ CAUTION

- Be very careful when transporting the product. There is a risk of the product falling and causing physical injury.
- Use appropriate moving equipment to transport each frame; ensure the equipment is capable of supporting the weights listed.
- Some products use polypropylene bands for packaging. Ⓞ Do not use polypropylene bands to lift the unit.
- Support the outdoor unit at a minimum of four points to avoid slippage from rigging apparatus.

⚠ NOTE

- Make sure the outdoor unit is in its original packaging to avoid damage during local transport.
- At the time of delivery, the package must be checked for any damage (exterior and interior). Report any damage to the carrier claims agent immediately.
- Handle the outdoor unit with care. Keep the outdoor unit upright to avoid damaging inside components.
- If a forklift is to transport the outdoor unit, the forklift arms must pass through the openings at the bottom.
- If a crane is to suspend the outdoor unit, it is required that two (2) ropes at least twenty-three (23) feet in length be used. Pass the ropes under the unit. Pass the rope through the two (2) forklift slots each at the front and rear of the outdoor unit.
- To prevent damage to the outdoor unit, always lift the unit with the ropes attached at four (4) points at an angle of $\leq 40^\circ$.
- Always include padding to protect the outdoor unit from rope damage, and take into consideration the outdoor unit's center of gravity.
- Remove the wood pallet from the bottom of the outdoor unit drain pan before installing it to the platform / bracket / etc. Improper installation with the wood pallets still on the outdoor unit will cause the heat exchanger to freeze, resulting in operation malfunction.

General Outdoor Unit Mounting

Any underlying structure or foundation must be designed to support the weight of the outdoor unit. Ⓞ Avoid placing the unit in a low lying area where water and ice will accumulate. Securely attach the outdoor unit to a condenser pad, base rails, or a mounting platform that is solidly anchored to the ground or building structure. When installing the outdoor unit on the wall or roof top, securely anchor the mounting base to account for wind, earthquakes, or vibration.

Anchoring the Outdoor Unit

- Tightly anchor the outdoor unit with a bolt and nut to a concrete or rigid platform (see next page for more details).
- When installing on a wall (with field-supplied brackets), roof, or rooftop, securely anchor the mounting platform with nails, taking into consideration the possibility of strong winds or earthquakes.
- If there is a possibility of vibration from the outdoor unit transmitting to the building, add an anti-vibration material.

Note:

Follow applicable local codes for clearance, mounting, anchor and vibration attenuation requirements.

Outdoor Unit Platform Concrete Specifications

- Concrete foundations must be made of one part cement, two parts sand, and four parts gravel.
- The surface of the foundation must be finished with mortar with rounded edges, and weatherproofed.
- See table and figures on the next page for height, width, etc., requirements.
- Include an area for drainage around the foundation to ensure condensate thoroughly drains away from the outdoor unit.

Figure 5: Examples of Outdoor Unit Mounting Methods.

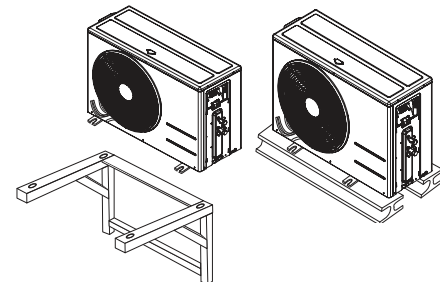

GENERAL INSTALLATION GUIDELINES

Outdoor Unit Mounting

Outdoor Unit Platform Dimensional Requirements

Note:

- All referenced materials are to be field supplied. Images are not to scale.
- Review the specifications for field-supplied pad mounts or brackets to verify that outdoor dimension requirements are met.

Figure 6: LUU090HV and LUU120HV Outdoor Units.

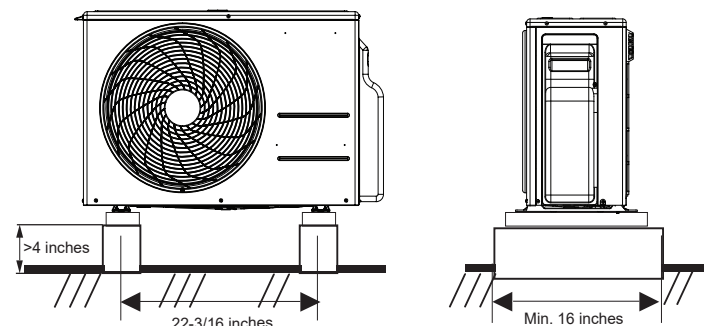
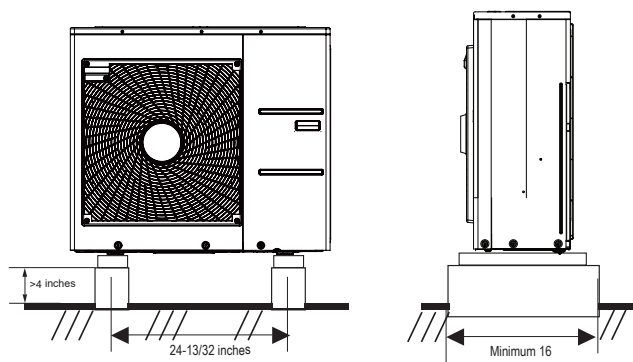

Figure 7: LUU180HV and LUU240HV Outdoor Units.



Bolting the Outdoor Unit to the Platform

1. Ensure that the concrete platform will not degrade easily, and has enough structural strength to bear the weight of the unit.
2. Include an H-beam support. Firmly attach the corners, otherwise the support will bend.
3. Use a hexagon nut.
4. Use anti-vibration material.
5. If there is a possibility of vibration from the outdoor unit transmitting to the building, add an anti-vibration material to the platform.
6. Seal all wiring and piping access holes with field-supplied sealing material to prevent animals and bugs from entering the unit.

Figure 8: LUU360HV and LUU420HV Outdoor Units.

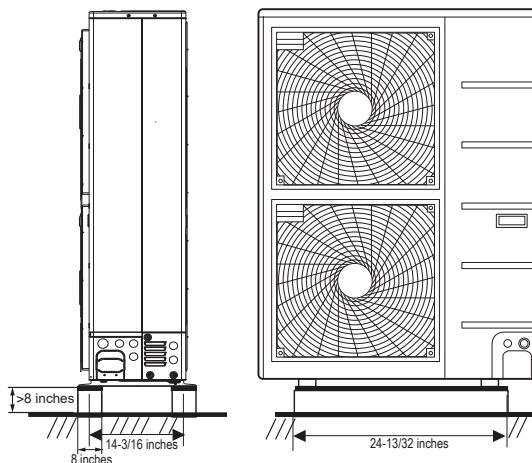

Table 11: Outdoor Unit Foundation Specifications.

Outdoor Unit	Bolt Type	Concrete Height	Bolt Depth
LUU090HV, LUU120HV, LUU180HV, LUU240HV	M10-J	Minimum Four (4) Inches	Minimum Three (3) Inches
LUU360HV, LUU420HV	M10-J	Minimum Eight (8) Inches	Minimum Three (3) Inches

Figure 9: Example of Using an Insert for a Hole in a Reinforced Concrete Beam.

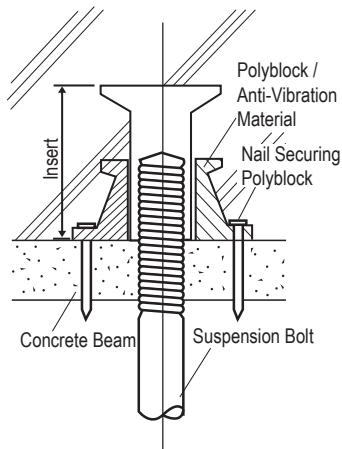

Figure 10: Close up of a Bolt Attachment.

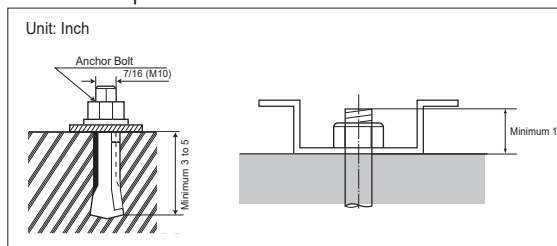
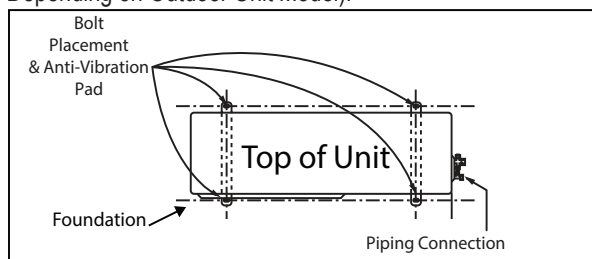

Figure 11: Bolting the Outdoor Unit to the Platform (Piping Location Will Differ Depending on Outdoor Unit Model).



GENERAL INSTALLATION GUIDELINES

Indoor Unit Location Selection

Selecting the Best Location for the Indoor Unit

⚠ DANGER

To avoid the possibility of fire, Ⓞ do not install the unit in an area where combustible gas will generate, flow, stagnate, or leak. Failure to do so will cause serious bodily injury or death. Before beginning installation, read the safety summary at the beginning of this manual.

Note:

Do's

Select a location for installing the indoor units that will meet the following conditions:

- Place in an area that is level and with enough strength to bear the weight of the indoor unit(s).
- Place the unit where air circulation will not be blocked.
- Place the unit where operating sound from the unit will not disturb occupants.
- Include enough space for service access.
- Place the indoor unit in a location where it can be easily connected to the outdoor unit.
- Place the unit where drainage can be obtained easily and to minimize the length of the condensate drain piping; include space for drainage to ensure condensate flows properly out of the unit when it is in cooling mode.
- Ensure there is sufficient space from the ceiling and floor.
- Place the unit in a location where electrical noise / electromagnetic waves will not impact operation. Maintain proper distances between the indoor units and electric wires, audio and visual appliances, breaker / circuit panels, etc.
- Use the provided pattern to determine the size of the ceiling opening and the hanging bolt locations required by the unit.

Ⓞ Do Not's

- The unit should not be installed near a heat or steam source, or where considerable amounts of oil, iron powder, or flour are used.
- No obstacles to air circulation around the unit; keep proper distances from ceilings, doorways, floor, walls, etc.
- The unit should not be installed in an area where sulfuric acid and flammable or corrosive gases are generated, flowed, vented into, stagnate, leak, or stored.
- The unit should not be installed in a location where acidic solution and spray (sulfur) are often used.
- Avoid installing the unit near high-frequency generators or near any equipment that generates an electromagnetic field (minimum 3-1/3 feet away).
- Do not install the unit near a doorway.

⚠ WARNING

The unit must not be installed where sulfuric acid and flammable or corrosive gases are generated, vented into, or stored. There is risk of fire, explosion, and physical injury or death.

Figure 12: Indoor Unit Clearance Requirements.

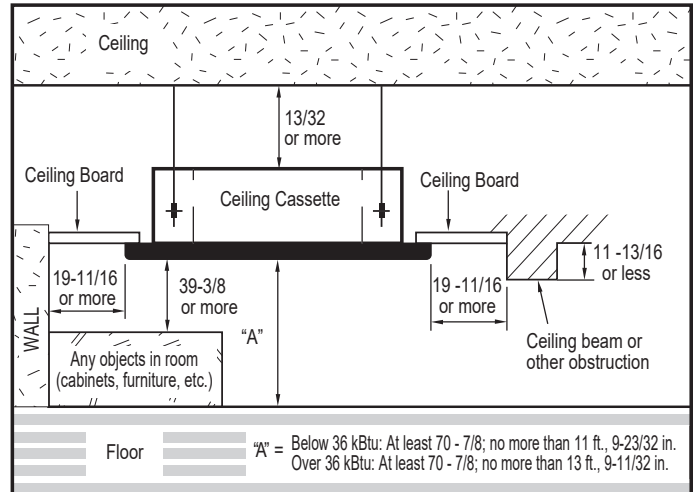

Unit: Inch

GENERAL INSTALLATION GUIDELINES

Indoor Unit Location Selection / Required Indoor Unit Clearances

NOTE

- Indoor units (IDUs)  must not be placed in an environment where the IDUs will be exposed to harmful volatile organic compounds (VOCs) or in environments where there is improper air make up or supply or inadequate ventilation. If there are concerns about VOCs in the environment where the IDUs are installed, proper air make up or supply and / or adequate ventilation should be provided. Additionally, in buildings where IDUs will be exposed to VOCs consider a factory-applied epoxy coating to the fan coils for each IDU.
- If the unit is installed near a body of water, certain components are at risk of being corroded. Appropriate anti-corrosion methods must be taken for the unit and all components.

The unit will be damaged, will malfunction, and / or will not operate as designed if installed in any of the conditions listed.

Installing in an Area Exposed to Unconditioned Air

In some installation applications, areas (floors, walls) in some rooms may be exposed to unconditioned air (room may be above or next to an unheated garage or storeroom). To countermeasure:

- Verify that carpet is or will be installed (carpet may increase the temperature by three [3] degrees).
- Add insulation between the floor joists.
- Install radiant heat or another type of heating system to the floor.

Installing in a High or Dropped Ceiling

High or dropped ceilings, often found in commercial buildings and offices, may cause a wide temperature differentiation. To countermeasure:

- Change the indoor unit mode selection to allow for higher ceilings (see table).
- Install an air circulator.
- Set the air discharge outlet so that heated air flows in a downward direction.
- Use a dual door system to protect the building gate or exit.

Table 12: Indoor Unit High Ceiling Mode Selection Options (LCN098HV, LCN128HV, LCN188HV).

Ceiling Height	Mode Selection
≤7-1/2 feet	Low Ceiling
7-1/2 feet to 8-7/8 feet	Standard
8-7/8 feet to 10-3/16 feet	High Ceiling
10-3/16 feet to 11-13/16 feet	Very High Ceiling

Table 13: Indoor Unit High Ceiling Mode Selection Options (LCN249HV, LCN369HV, LCN429HV).

Ceiling Height	Mode Selection
≤8-7/8 feet	Low Ceiling
8-7/8 feet to 10-1/2 feet	Standard
10-1/2 feet to 11-13/16 feet	High Ceiling
11-13/16 feet to 13-13/16 feet	Very High Ceiling

Installing in an Area with High Humidity Levels

If the environment is prone to humidity levels of 80% or more (near the ocean, lakes, etc.) or where steam could collect in the plenum:

- Install additional insulation to the indoor unit (glass wool insulation >13/32 inches thick).
- Install additional insulation to the refrigerant piping (insulation >13/16 inches thick).
- Seal all gaps between the indoor unit and the ceiling tiles (make the area air tight) so that humidity does not transfer from the plenum to the conditioned space. Also, add a ceiling grille for ventilation.

Figure 13: Installing in a Highly Humid Location.

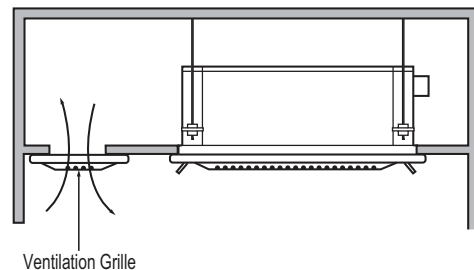

GENERAL INSTALLATION GUIDELINES

Hanging the Indoor Unit

Preparing the Installation Area

1. Cassette indoor units include installation guides (templates) that depict the exact dimensions necessary for the ceiling opening. One is a paper template that is found in the cassette indoor unit shipping materials; the other template is the cardboard on the bottom of the packaging.
2. Using one of the templates, choose the location for the indoor unit. Mark where the four (4) suspension / hanger bolts, refrigerant piping, and drain hose should be. Suspension bolt angle must account for drain direction.
3. Drill holes for the four (4) suspension / hanger bolts.

Note:

For easier installation, attach the accessories (except for the decoration panel) before hanging the indoor unit.

Figure 14: Cassette Indoor Unit Templates.

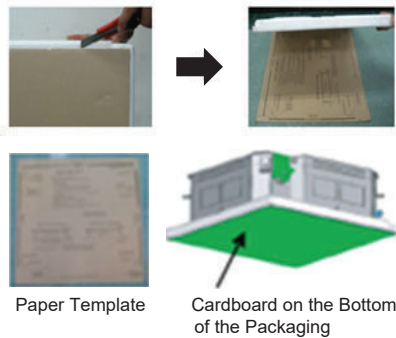

Figure 15: Drilling Holes Using Template.

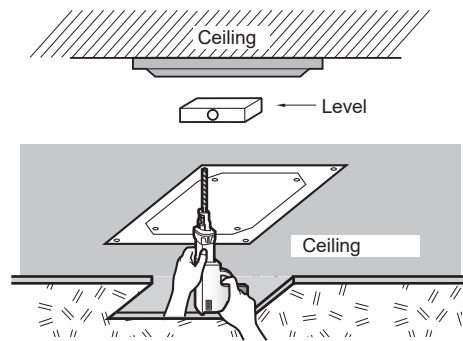

Figure 16: 2 x 2 Cassette Ceiling Opening Dimensions and Bolt Locations.

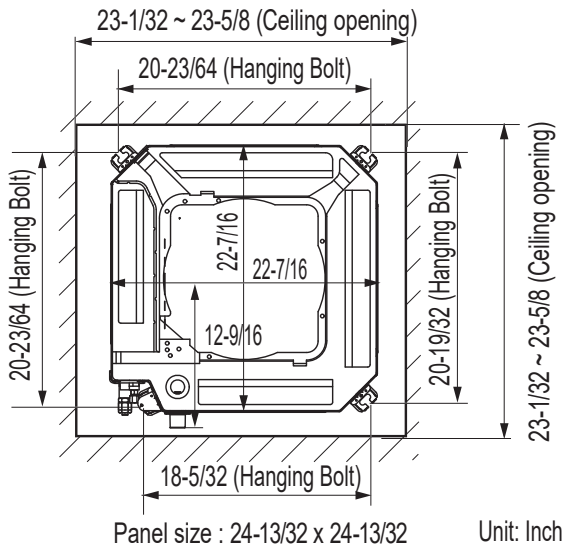
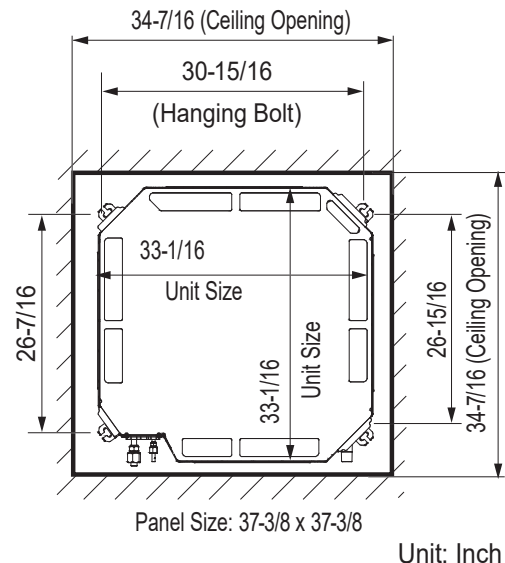

Figure 17: 3 x 3 Cassette Ceiling Opening Dimensions and Bolt Locations.



⚠ WARNING

- The threaded rod hangers (bolts) and hardware must be securely installed to prevent the frame falling from its location. There is risk of personnel injury from falling equipment.
- Installation work must be performed by trained personnel and in accordance with all local or other applicable codes. There is risk of personnel injury from incorrect installation.
- During installation, ⚡ do not damage the cable / wiring. There is a risk of electrical shock, fire, physical injury and / or death.

GENERAL INSTALLATION GUIDELINES

Hanging the Indoor Unit

Note:

- The threaded rod hangers (bolts) and hardware must be securely installed to prevent the frame falling from its location. There is risk of property damage from falling equipment.
- Ensure the unit is properly installed. Incorrectly installed units can result in degraded performance or an inoperative unit/system.
- Use a level indicator to ensure the frame is installed on a level plane. Incorrectly installed units can result in degraded performance or an inoperative unit/system.
- Use the provided pattern to determine the size of the ceiling opening and the threaded rod hanger locations required by the unit.

Hanging the Indoor Unit

The following parts are field supplied:

- Hanging bolt - W-3/8" or M10
- Nut - W-3/8" or M10
- Spring washer - M10

Figure 18: Installing the Hanging Bolt in the Ceiling.

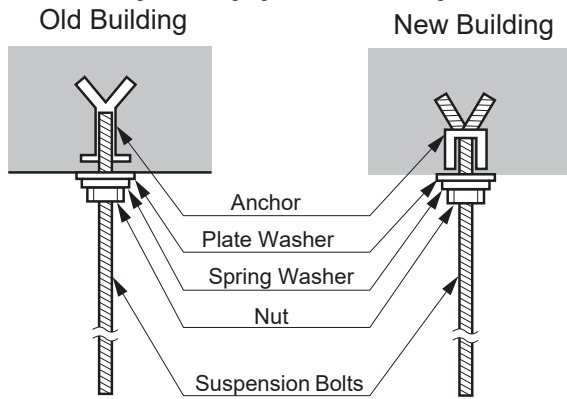

For New Ceilings

1. Use a sunken insert, a sunken anchor, or any other field-supplied part to reinforce the ceiling so that it can bear the weight of the indoor unit. Use a temporary washer plate to more easily set up the unit suspension location.
2. Ceiling height is shown on the side of the installation guide (template). Adjust the height of the unit accordingly. Adjust the clearance before hanging the indoor unit.
3. Refer to the installation guide (template) for the dimensions to the ceiling opening. Match the center of the indoor unit (labeled) to the center indicated on the installation guide.
4. Align the installation guide (template) with the label attached to the unit (affixing the template to the unit if desired) to properly place the unit.
5. Remove the temporary washer plate and position the indoor unit hanger brackets on the bolts. Secure with nuts and washers on the top and bottom of the hanger brackets.
6. Ceiling-cassette indoor units are equipped with a built-in drain pump, therefore, the unit must be installed horizontally or condensate will drip out and cause product malfunction. Measure the unit at each corner to verify that it is level.
7. Remove the installation guide (template).

The following parts are included with the indoor unit:

- Flat washer - M10

Figure 19: Installation Diagram.

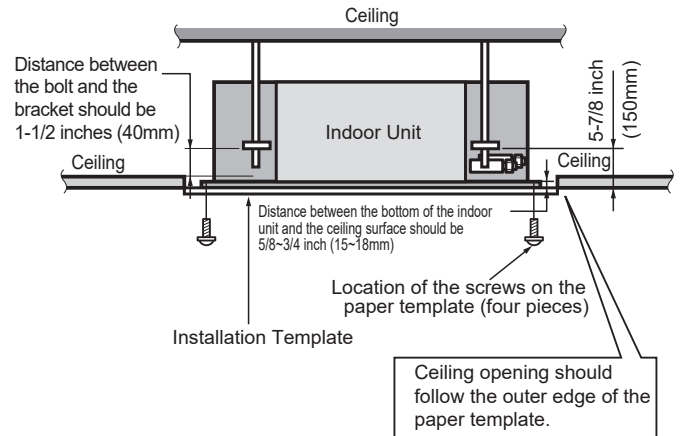
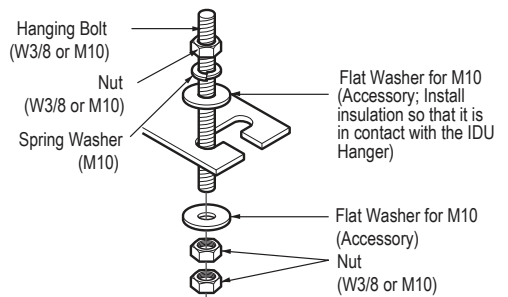

Figure 20: Hanging the Indoor Unit.



GENERAL INSTALLATION GUIDELINES

Hanging the Indoor Unit / Drilling the Piping Hole

For Existing Ceilings

1. Use anchors when installing the indoor unit in an existing ceiling.
2. Ceiling height is shown on the side of the installation guide (template). Adjust the height of the unit accordingly. Adjust the clearance before hanging the indoor unit.
3. Remove the temporary washer plate and position the indoor unit hanger brackets on the bolts. Secure with nuts and washers on the top and bottom of the hanger brackets.
4. Ceiling-cassette indoor units are equipped with a built-in drain pump and float switch, therefore, the unit must be installed horizontally or condensate will drip out and cause product malfunction. Measure the unit at each corner to verify that it is level.
5. Remove the installation guide (template).

Drilling the Piping Hole

Follow all piping clearance recommendations.

1. Using a 2-5/8 inch hole core drill bit, drill a hole following installation guidelines and application needs. Avoid obstructions in the wall such as electrical wires or conduits and water or gas pipes.
 - The slant of the hole must be 3/16 inches to 5/16 inches from level with the slant being upward on the indoor unit side and downward on the outdoor unit side.
2. Finish off the newly drilled hole as shown with bushing and sleeve covering to prevent damage to the insulation and piping.
 - Sleeve and bushing prevents piping / bundling damage.

Note:

- See *Refrigerant Piping Connections for Indoor Unit* for information on piping installation.
- See the *Refrigerant Piping Connections* section of this manual for information on indoor unit piping connection installation.
- See the *Electrical Connections* section of this manual for information on conduit / electrical wiring to the indoor unit.

Figure 21: Drilling the Piping Hole.

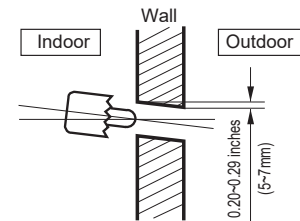

Drill the piping access hole slightly tilted to the outdoor side using a Ø2-3/4 inch (70mm) hole-core drill.

REFRIGERANT SAFETY STANDARDS / DEVICE CONNECTION LIMITATIONS

Refrigerant Safety Standards

ASHRAE Standards 15-2010 and 34-2010 address refrigerant safety and the maximum allowable concentration of refrigerant in an occupied space. Refrigerant will dissipate into the atmosphere, but a certain volume of air is required to safely dissipate the refrigerant. For R410A refrigerant, the maximum allowable concentration of refrigerant is 26 lbs./1,000 cubic feet (Addendum L modified the RCL to 26) of occupied spaces. Buildings with 24-hour occupancy are allowed half of that concentration.

If a single zone system develops a refrigerant leak, the entire refrigerant charge of the system will dump into the area where the leak occurs. To meet ASHRAE Standards 15 and 34, the smallest room volume on the system must be calculated and compared to the maximum allowable concentration. Also consult state and local codes in regards to refrigerant safety.

Device Connection Limitations

A single-zone system consists of one outdoor unit and one indoor unit. One of the most critical elements of a single-zone system is the refrigerant piping. If the connection piping is not within allowable limits, there will be reliability, performance, noise, and vibration issues. The table below lists pipe length limits that must be followed in the design of a Single Zone Four-Way Ceiling Cassette refrigerant pipe system. Refer to the figures for maximum length and elevation of piping.

Figure 22: Typical LC098HV and LC128HV System Layout.

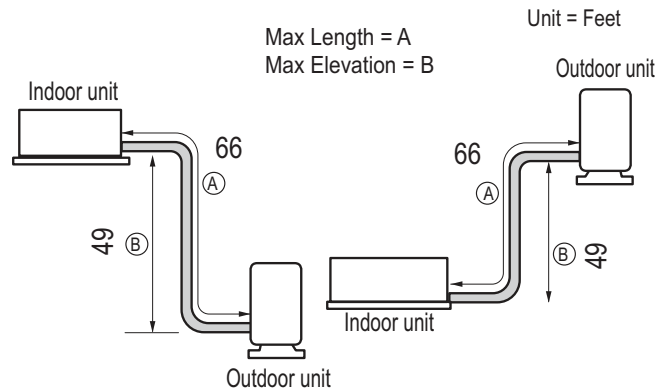

Figure 24: Typical LC349HV and LC429HV System Layout.

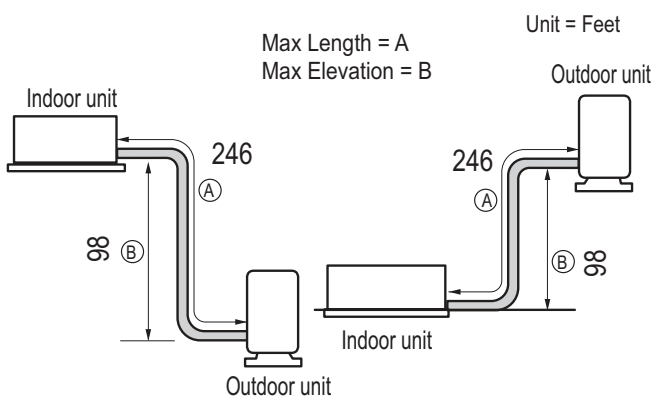

Figure 23: Typical LC188HV, and LC249HV System Layout.

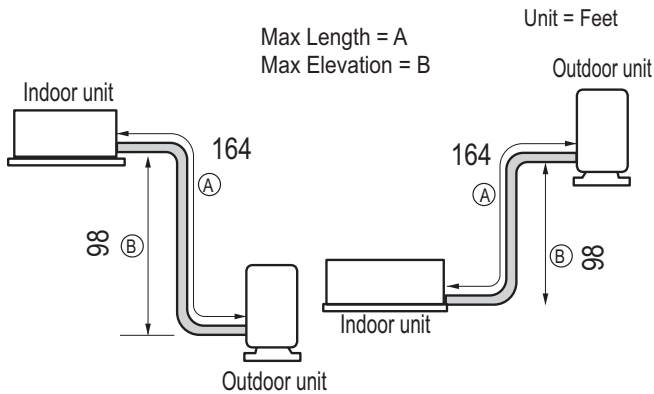

Table 14: Single-Zone Four-Way Ceiling Cassette Refrigerant Piping System Limitations.

System Model Name		LC098HV, LC128HV	LC188HV, LC249HV	LC369HV, LC429HV
Pipe Sizes	Vapor	3/8	5/8	5/8
	Liquid	1/4	3/8	3/8
Pipe Length (ELF = Equivalent Length of Pipe)	Standard length (no add'l refrigerant)	24.6 feet	24.6 feet	24.6 feet
	Longest total equivalent piping length	66 feet	164 feet	246 feet
	Shortest total equivalent piping length	16.4	16.4	16.4
	Distance between fittings and indoor or outdoor units	≥20 inches	≥20 inches	≥20 inches
Elevation (All Elevation Limitations are Measured in Actual Feet)	If outdoor unit is above indoor unit	49 feet	98.4 feet	98.4 feet
	If outdoor unit is below indoor unit	49 feet	98.4 feet	98.4 feet
Additional Refrigerant Needed (oz/ft)		0.22	0.43	0.43

SELECTING FIELD SUPPLIED PIPING

Selecting Field-Supplied Copper Piping

Note:

Always follow local codes when selecting and installing copper pipe and piping system components.

Approved piping for use with LG Single Zone products will be marked “R410 RATED” along the length of the pipe. Piping wall thickness must meet local code requirements and be approved for a maximum operating pressure of 551 psi. When bending piping, try to keep the number of bends to a minimum, and use the largest radii possible to reduce the equivalent length of installed piping; also, bending radii greater than ten (10) piping diameters can minimize pressure drop. Be sure no traps or sags are present.

For Single Zone Systems

LG prefers the use of ACR copper piping rated at the system working pressure was used.

Note:

Always properly support the piping as per the instructions on page 34.

Table 15: ACR Rated Copper Tubing Material.

Type	Seamless Phosphorous Deoxidized
Class	UNS C12200 DHP
Straight Lengths	H58 Temper
Coils	O60 Temper

Table 16: Piping Tube Thicknesses.

OD (in)	1/4	3/8	1/2	5/8	3/4	7/8	1-1/8	1-3/8	1-5/8
Material	Rigid or Soft ACR Rated for R410A			Rigid or Soft ACR Rated for R410A					
Min. Bend Radius (in)	0.563	0.9375	1.5	2.25	3.0	3.0	3.5	4.0	4.5
Min. Wall Thickness (in)	0.03	0.03	0.03	0.03	0.03	0.03	0.03	0.04	0.050

Table 17: ACR Copper Tubing Dimensions and Physical Characteristics¹⁻³.

Nominal Pipe Outside Diameter (in)	Actual Outside Diameter (in)	Tempered (Hard Drawn)			Annealed (Soft)		
		Nominal Wall Thickness (in)	Weight (lb/ft)	Cubic ft per Linear ft	Nominal Wall Thickness (in)	Weight (lb/ft)	Cubic ft per Linear ft
1/4	0.250	--	--	--	0.030	0.081	0.00020
3/8	0.375	0.030	0.126	0.00054	0.032	0.134	0.00053
1/2	0.500	0.035	0.198	0.00101	0.032	0.182	0.00103
5/8	0.625	0.040	0.285	0.00162	0.035	0.251	0.00168
3/4	0.750	0.042	0.362	0.00242	0.042	0.362	0.00242
7/8	0.875	0.045	0.455	0.00336	0.045	0.455	0.00336
1-1/8	1.125	0.050	0.655	0.00573	0.050	0.655	0.00573

¹All dimensions provided are in accordance with ASTM B280 – Standard..

²Design pressure = 551 psig.

³The Copper Tube Handbook, 2010, Copper Development Association Inc., 260 Madison Avenue, New York, NY 10016.

Note:

- Commercially available piping often contains dust and other materials. Always blow it clean with a dry inert gas.
- Prevent dust, water or other contaminants from entering the piping during installation.



COPPER EXPANSION AND CONTRACTION

Copper Expansion and Contraction

Under normal operating conditions, the vapor pipe temperature of a Duct Free System can vary as much as 280°F. With this large variance in pipe temperature, the designer must consider pipe expansion and contraction to avoid pipe and fitting fatigue failures.

Refrigerant pipe along with the insulation jacket form a cohesive unit that expands and contracts together. During system operation, thermal heat transfer occurs between the pipe and the surrounding insulation.

If the pipe is mounted in free air space, no natural restriction to movement is present if mounting clamps are properly spaced and installed. When the refrigerant pipe is mounted underground in a utility duct stacked among other pipes, natural restriction to linear movement is present. In extreme cases, the restrictive force of surface friction between insulating jackets could become so great that natural expansion ceases and the pipe is “fixed” in place. In this situation, opposing force caused by change in refrigerant fluid/vapor temperature can lead to pipe/fitting stress failure.

The refrigerant pipe support system must be engineered to allow free expansion to occur. When a segment of pipe is mounted between two fixed points, provisions must be provided to allow pipe expansion to naturally occur. The most common method is the inclusion of expansion Loop or U-bends. Each segment of pipe has a natural fixed point where no movement occurs. This fixed point is located at the center point of the segment assuming the entire pipe is insulated in a similar fashion. The natural fixed point of the pipe segment is typically where the expansion Loop or U-bend must be.

Linear pipe expansion can be calculated using the following formula:

$$LE = C \times L \times (T_r - T_a) \times 12$$

LE	=	Anticipated linear tubing expansion (in.)
C	=	Constant (For copper = 9.2×10^{-6} in./in.°F)
L	=	Length of pipe (ft.)
T_r	=	Refrigerant pipe temperature (°F)
T_a	=	Ambient air temperature (°F)
12	=	Inches to feet conversion (12 in./ft.)

See table on next page for precalculated anticipated expansion for various pipe sizes and lengths of refrigerant tubing.

To find the anticipated expansion value:

1. From the table on the next page, find the row corresponding with the actual feet of the straight pipe segment.
2. Estimate the minimum and maximum temperature of the pipe.
3. In the column showing the minimum pipe temperature, look up the anticipated expansion distance corresponding to the segment length. Do the same for the maximum pipe temperature.
4. Calculate the difference in the two expansion distance values. The result will be the change in pipe length.

1. From the “Linear Thermal Expansion of Copper Tubing in Inches” Table on the next page, find the row corresponding with the actual length of the straight pipe segment.

2. Estimate the minimum and maximum temperature of the pipe. In the column showing the minimum pipe temperature, look up the anticipated expansion distance. Do the same for the maximum pipe temperature.

3. Calculate the difference in the two expansion distance values. The result will be the anticipated change in pipe length.

General Example:

A system is installed and the design shows that there is a 100 foot straight segment of tubing between an indoor unit and the outdoor unit. In heating, this pipe transports hot gas vapor to the indoor units at 120 °F. In cooling, the same tube is a suction line returning refrigerant vapor to the outdoor unit at 40 °F. Look up the copper tubing expansion at each temperature and calculate the difference.

Vapor Line

Transporting Hot Vapor: 100 ft. pipe at 120 °F = 1.40 in.

Transporting Suction Vapor: 100 ft. pipe at 40 °F = 0.40 in.

Anticipated Change in Length: 1.40 in. – 0.40 in. = 1.00 in.

Liquid Line

The liquid temperature remains relatively the same temperature; only the direction of flow will reverse. Therefore, no significant change in length of the liquid line is anticipated.

When creating an expansion joint, the joint height must be a minimum of two times the joint width. Although different types of expansion arrangements are available, the data for correctly sizing an Expansion Loop is provided in the “Radii of Coiled Expansion Loops and Developed Lengths of Expansion Offsets” Table on the next page. Use soft copper with long radius bends on longer runs or long radius elbows for shorter pipe segments. Using the anticipated linear expansion (LE) distance calculated, look up the Expansion Loop or U-bend minimum design dimensions. If other types of expansion joints are chosen, design per ASTM B-88 Standards.

COPPER EXPANSION AND CONTRACTION

Table 18: Linear Thermal Expansion of Copper Tubing in Inches.

Pipe Length ¹	Fluid Temperature °F																			
	35°	40°	45°	50°	55°	60°	65°	70°	75°	80°	85°	90°	95°	100°	105°	110°	115°	120°	125°	130°
10	0.04	0.04	0.05	0.06	0.06	0.07	0.08	0.08	0.09	0.09	0.10	0.10	0.11	0.11	0.11	0.12	0.13	0.14	0.15	0.15
20	0.08	0.08	0.10	0.12	0.13	0.14	0.15	0.16	0.17	0.18	0.19	0.20	0.21	0.22	0.22	0.23	0.26	0.28	0.29	0.30
30	0.12	0.12	0.15	0.18	0.20	0.21	0.23	0.24	0.26	0.27	0.29	0.30	0.32	0.33	0.32	0.35	0.39	0.42	0.44	0.45
40	0.16	0.16	0.20	0.24	0.26	0.28	0.30	0.32	0.34	0.36	0.38	0.40	0.42	0.44	0.43	0.46	0.52	0.56	0.58	0.60
50	0.20	0.20	0.25	0.30	0.33	0.35	0.38	0.40	0.43	0.45	0.48	0.50	0.53	0.55	0.54	0.58	0.65	0.70	0.73	0.75
60	0.24	0.24	0.30	0.36	0.39	0.42	0.45	0.48	0.51	0.54	0.57	0.60	0.63	0.66	0.65	0.69	0.78	0.84	0.87	0.90
70	0.28	0.28	0.35	0.42	0.46	0.49	0.53	0.56	0.60	0.63	0.67	0.70	0.74	0.77	0.76	0.81	0.91	0.98	1.02	1.05
80	0.32	0.32	0.40	0.48	0.52	0.56	0.60	0.64	0.68	0.72	0.76	0.80	0.84	0.88	0.86	0.92	1.04	1.12	1.16	1.20
90	0.36	0.36	0.45	0.54	0.59	0.63	0.68	0.72	0.77	0.81	0.86	0.90	0.95	0.99	0.97	1.04	1.17	1.26	1.31	1.35
100	0.40	0.40	0.50	0.60	0.65	0.70	0.75	0.80	0.85	0.90	0.95	1.00	1.05	1.10	1.08	1.15	1.30	1.40	1.45	1.50
120	0.48	0.48	0.60	0.72	0.78	0.84	0.90	0.96	1.02	1.08	1.14	1.20	1.26	1.32	1.30	1.38	1.56	1.68	1.74	1.80
140	0.56	0.56	0.70	0.84	0.91	0.98	1.05	1.12	1.19	1.26	1.33	1.40	1.47	1.54	1.51	1.61	1.82	1.96	2.03	2.10
160	0.64	0.64	0.80	0.96	1.04	1.12	1.20	1.28	1.36	1.44	1.52	1.60	1.68	1.76	1.73	1.84	2.08	2.24	2.32	2.40
180	0.72	0.72	0.90	1.08	1.17	1.26	1.35	1.44	1.53	1.62	1.71	1.80	1.89	1.98	1.94	2.07	2.34	2.52	2.61	2.70

¹Pipe length baseline temperature = 0°F. "Expansion of Carbon, Copper and Stainless Steel Pipe," *The Engineers' Toolbox*, www.engineeringtoolbox.com.

Figure 25: Coiled Expansion Loops and Offsets (Plan View).

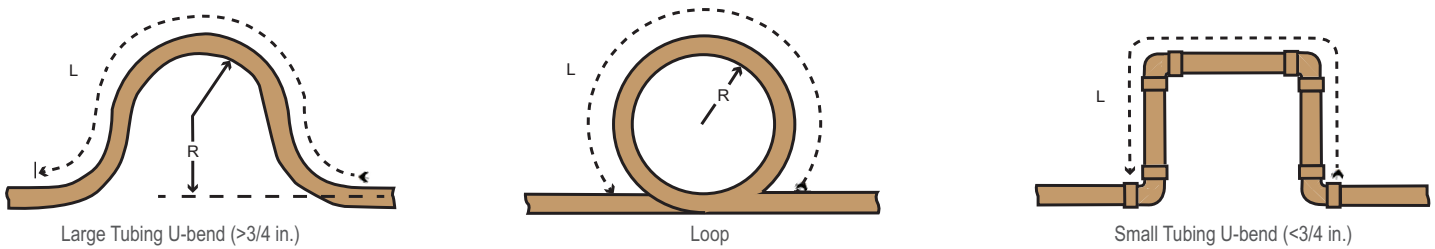

Note:

All expansion loops and offsets must be installed in the horizontal plane to prevent the possibility of trapping oil. Loops and offsets in vertical risers must also be installed in a horizontal plane.

Table 19: Radii of Coiled Expansion Loops and Developed Lengths of Expansion Offsets.

Anticipated Linear Expansion (LE) (inches)		Nominal Tube Size (OD) inches			
		1/4	3/8	1/2	3/4
1/2	R ¹	6	7	8	9
	L ²	38	44	50	59
1	R ¹	9	10	11	13
	L ²	54	63	70	83
1-1/2	R ¹	11	12	14	16
	L ²	66	77	86	101
2	R ¹	12	14	16	19
	L ²	77	89	99	117
2-1/2	R ¹	14	16	18	21
	L ²	86	99	111	131
3	R ¹	15	17	19	23
	L ²	94	109	122	143
3-1/2	R ¹	16	19	21	25
	L ²	102	117	131	155
4	R ¹	17	20	22	26
	L ²	109	126	140	166

¹R = Centerline Length of Pipe.

²L = Centerline Minimum Radius (inches).



Due to our policy of continuous product innovation, some specifications may change without notification. © LG Electronics U.S.A., Inc., Englewood Cliffs, NJ. All rights reserved. "LG" is a registered trademark of LG Corp.

PIPING HANDLING

Piping Materials and Handling



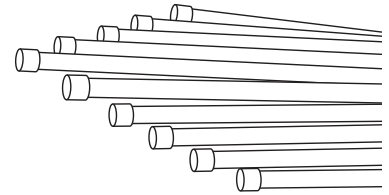

Pipes used for the refrigerant piping system must include the specified thickness, and the interior must be clean.

While handling and storing,  do not bend or damage the pipes, and take care not to contaminate the interior with dust, moisture, etc.

Keep Pipes Capped While Storing.

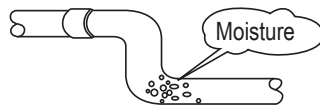

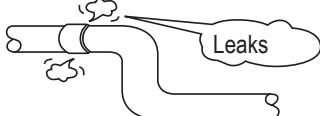
Keep refrigerant pipe dry, clean, and airtight.

	Dry	Clean	Airtight
	No moisture should be inside the piping.	No dust should be inside the piping.	No leaks should occur.
			
Possible Problems	<ul style="list-style-type: none"> - Significant hydrolysis of refrigerant oil. - Refrigerant oil degradation. - Poor insulation of the compressor. - System does not operate properly. - EEVs, capillary tubes are clogged. 	<ul style="list-style-type: none"> - Refrigerant oil degradation. - Poor insulation of the compressor. - System does not operate properly. - EEVs and capillary tubes become clogged. 	<ul style="list-style-type: none"> - Refrigerant gas leaks / shortages. - Refrigerant oil degradation. - Poor insulation of the compressor. - System does not operate properly.
Solutions	<ul style="list-style-type: none"> - Remove moisture from the piping. - Piping ends should remain capped until connections are complete. -  Do not install piping on a rainy day. - Connect piping properly at the unit's side. - Remove caps only after the piping is cut, the burrs are removed, and after passing the piping through the walls. - Evacuate system to a maximum of 500 microns and insure the vacuum holds at that level for 1 hour. 	<ul style="list-style-type: none"> - Remove dust from the piping. - Piping ends should remain capped until connections are complete. - Connect piping properly at the side of the unit. - Remove caps only after the piping is cut and burrs are removed. - Retain the cap on the piping when passing it through walls, etc. 	<ul style="list-style-type: none"> - Test system for air tightness. - Perform brazing procedures that comply with all applicable standards. - Perform flaring procedures that comply with all applicable standards. - Perform flanging procedures that comply with all applicable standards. - Ensure that refrigerant lines are pressure tested to 550 psig and hold for 24 hours.

REFRIGERANT SYSTEM ENGINEERING

Proper system operation depends on the installer using utmost care while assembling the piping system. The following pages are an overview of best practices when installing the refrigerant piping system.

Note:

LG Electronics U.S.A., Inc., is not responsible for any piping calculations, refrigerant leaks, degradation of performance, any other potential problems or damages caused by the interconnecting piping, their joint connections, isolation valves, or introduced debris inside the piping system.

⊘ No Pipe Size Substitutions

Use only the pipe size selected by the information in this manual. Using a different size is prohibited and will result in a system malfunction or failure to work at all.

⊘ No In-line Refrigeration Components

Components such as oil traps, solenoid valves, filter-driers, sight glasses, tee fittings, and other after-market accessories are ⊘ not permitted on the refrigerant piping system between the outdoor units and the indoor units. LG Single Zone systems are provided with redundant systems that make sure oil is properly returned to the compressor. Sight-glasses and solenoid valves will cause vapor to form in the liquid stream. Over time, driers will deteriorate and introduce debris into the system. The designer and installer must verify the refrigerant piping system is free of traps, sagging pipes, sight glasses, filter driers, etc.

Field-Provided Isolation Ball Valves

LG maintains a neutral position on using isolation valves in LG HVAC refrigerant piping systems. LG does not endorse any manufacturer of isolation valves. It is recognized that installing isolation valves will simplify future maintenance requirements, and, if used, considerations must be taken including, but not limited to, the following:

- Pressure drops for any component used, including isolation valves, must be known in equivalent pipe length and calculated into the total and segment equivalent piping lengths and compared to product design limitations.
- In all cases, materials must be suitable for the application and any applicable codes, including, but not limited to, diameter and wall thickness continuity per ACR standards.

Failure to do so will cause significant performance degradation. Proper leak checks must be performed. Using isolation valves does not automatically void any LG product warranty, however, a limited warranty will be voided in whole or part if any field supplied accessory fail in any way that causes product failure.

Using Elbows

Field-supplied elbows are allowed if they are long radius and designed for use with R410A refrigerant. The designer and installer, however, must be cautious with the quantity and size of fittings used, and must account for the additional pressure losses in equivalent pipe length calculation for each branch. The equivalent pipe length of each elbow must be added to each pipe segment manually (see table).

Table 20: Equivalent Piping Length for Elbows.

Component	Size (Inches)				
	1/4	3/8	1/2	5/8	3/4
Elbow (ft.)	0.5	0.6	0.7	0.8	1.2

Pipe Bends

When bending soft copper, use long radius bends. Refer to the "Radii of Coiled Expansion Loops and Developed Lengths of Expansion Offsets" table for minimum radius specifications.

REFRIGERANT SYSTEM ENGINEERING

Obstacles

When an obstacle, such as an I-beam or concrete T, is in the path of the planned refrigerant pipe run, it is best practice to route the pipe over the obstacle. If adequate space is not available to route the insulated pipe over the obstacle, then route the pipe under the obstacle. In either case, it is imperative the length of the horizontal section of pipe above or below the obstacle be a minimum of three (3) times the longest vertical rise (or fall) at either end of the segment.

Figure 26: Installing Piping Above and Below an Obstacle.

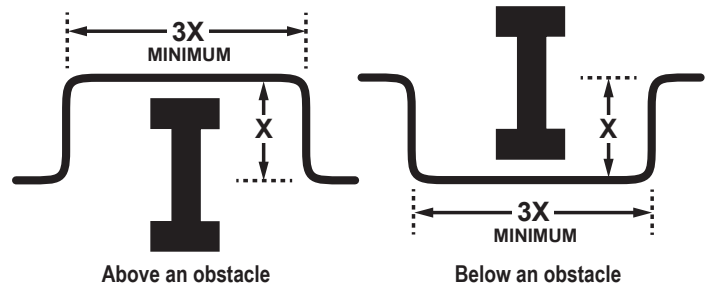

Pipe Supports

A properly installed pipe system must be adequately supported to avoid pipe sagging. Sagging pipes become oil traps that lead to equipment malfunction.

Pipe supports must \odot never touch the pipe wall; supports must be installed outside (around) the primary pipe insulation jacket. Insulate the pipe first because pipe supports must be installed outside (around) the primary pipe insulation jacket. Clevis hangers must be used with shields between the hangers and insulation. Field provided pipe supports must be designed to meet local codes. If allowed by code, use fiber straps or split-ring hangers suspended from the ceiling on all-thread rods (fiber straps or split ring hangers can be used as long as they do not compress the pipe insulation). Place a second layer of insulation over the pipe insulation jacket to prevent chafing and compression of the primary insulation within the confines of the support pipe clamp.

A properly installed pipe system will have sufficient supports to avoid pipes from sagging during the life of the system. As necessary, place supports closer for segments where potential sagging could occur. Maximum spacing of pipe supports must meet local codes. If local codes do not specify pipe support spacing, pipe must be supported:

- Maximum of five (5) feet on center for straight segments of pipe up to 3/4 inches outside diameter size.
- Maximum of six (6) feet on center for pipe up to one (1) inch outside diameter size.
- Maximum of eight (8) feet on center for pipe up to two (2) inches outside diameter size.

Wherever the pipe changes direction, place a hanger within twelve (12) inches on one side and within twelve (12) to nineteen (19) inches of the bend on the other side.

Figure 27: Pipe Hanger Details.

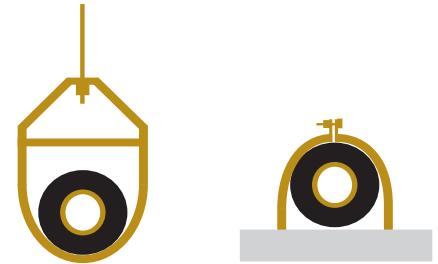

Note:

Use a 4" + long sheet curved sheet metal saddles between hanger bracket and insulation to promote linear expansion/contraction.

Figure 28: Typical Pipe Support Location—Change in Pipe Direction.

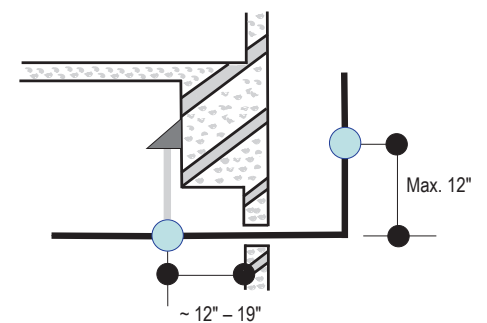

Pipe Sleeves at Penetrations

LG recommends that all pipe penetrations through walls, floors, and pipes buried underground be properly insulated and routed through an appropriate wall sleeve of sufficient size to prevent compression of refrigerant pipe insulation and free movement of the pipe within the sleeve. Use 4" + curved sheet metal saddles between the bottom surface of the pipe and the bottom surface of the penetration.

Figure 29: Pipe Sleeve Options.

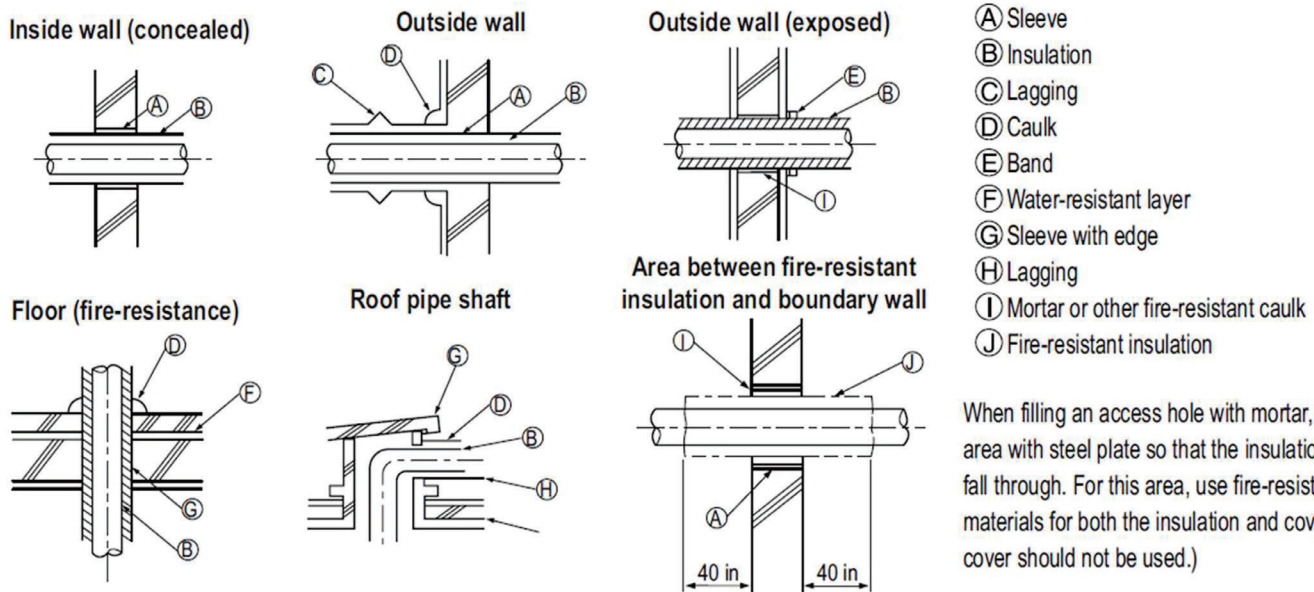

- (A) Sleeve
- (B) Insulation
- (C) Lagging
- (D) Caulk
- (E) Band
- (F) Water-resistant layer
- (G) Sleeve with edge
- (H) Lagging
- (I) Mortar or other fire-resistant caulk
- (J) Fire-resistant insulation

When filling an access hole with mortar, cover the area with steel plate so that the insulation will not fall through. For this area, use fire-resistant materials for both the insulation and cover. (Vinyl cover should not be used.)

Note:

Diameter of penetrations must be determined by pipe diameter plus the thickness of the insulation.

Underground Refrigerant Piping

Refrigerant pipe installed underground must be routed inside a vapor tight protective sleeve to prevent insulation deterioration and water infiltration. Refrigerant pipe installed inside underground casing must be continuous without any joints. Underground refrigerant pipe must be located at a level **below the frost line**.

Table 21: Utility Conduit Sizes.

Liquid Pipe ¹	Vapor Pipe ¹			
	3/8 (2.0 ^{2,5})	1/2 (2.0 ^{2,5})	5/8 (2-1/8 ^{2,5})	3/4 (2-1/4 ^{2,5})
1/4 (1.0) ³	4	4	4	4
3/8 (1-1/8) ³	4	4	4	5
1/2 (1-1/2) ⁴	5	5	5	5
5/8 (1-5/8) ⁴	5	5	5	5
3/4 (1-3/4) ⁴	5	5	5	5

¹OD pipe diameter in inches; Values in parenthesis () indicate OD of pipe with insulation jacket.
²Diameter of pipe with insulation. Thickness of pipe insulation is typical. Actual required thickness will vary based on surrounding ambient conditions and must be calculated and specified by the design engineer.
³Insulation thickness (value in parenthesis) = 3/8 inch.
⁴Insulation thickness (value in parenthesis) = 1 inch.
⁵Insulation thickness (value in parenthesis) = 3/4 inch.

Figure 30: Typical Arrangement of Single Zone Refrigerant Pipe and Cable(s) in a Utility Conduit.

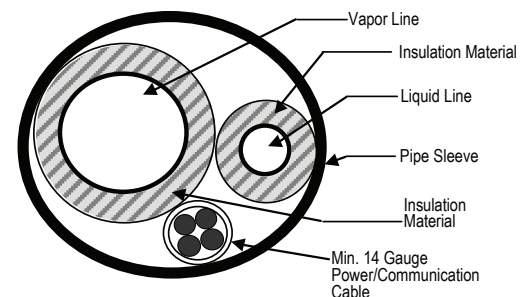

Note:

Provide expansion joints in long pipe segments and place in an accessible conduit box for inspection. Use galvanized curved sheet metal saddles at all mounting points. Pipe must be allowed to move freely linearly.

FLARING AND BRAZING PROCEDURES

Flaring and Brazing Procedures

One of the main causes of refrigerant leaks is a defective connection. For LG HVAC systems, the installer needs to know how perform both flared and brazed connections successfully.

Note:

- During installation, it is imperative to keep the piping system free of contaminants and debris such as copper burrs, slag, or carbon dust.
- Do not use kinked pipe caused by excessive bending in one specific area on its length.

Flaring Procedure

Note:

When selecting flare fittings, always use a 45° fitting rated for use with high pressure refrigerant R410A. Selected fittings must also comply with local, state, or federal standards.

1. Cut the pipe to length.
 - Measure the distance between the indoor unit and the outdoor unit.
 - Cut the pipes a little longer than measured distance.

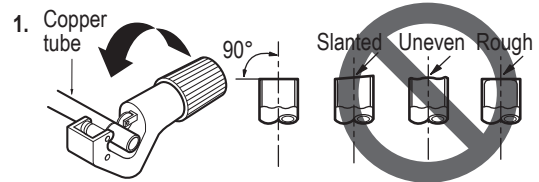

- 2A. Remove the burrs.
 - Completely remove all burrs from pipe ends.
 - When removing burrs, point the end of the copper pipe down to avoid introducing foreign materials in the pipe.

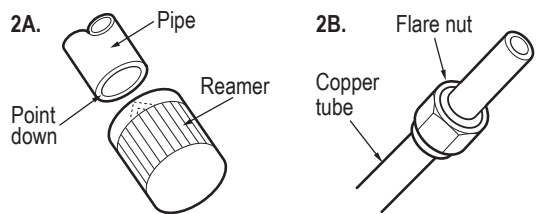

- 2B. Slide the flare nut onto the copper tube.

3. Flaring the pipe end.
 - Use the proper size flaring tool to finish flared connections as shown.
 - ALWAYS create a 45° flare when working with R410A.

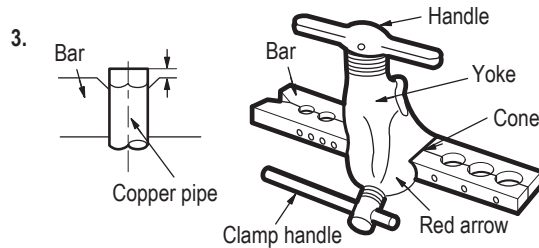

4. Carefully inspect the flared pipe end.
 - Compare the geometry with the figure to the right
 - If the flare is defective, cut it off and re-do procedure.
 - If flare looks good, blow the pipe clean with dry nitrogen.

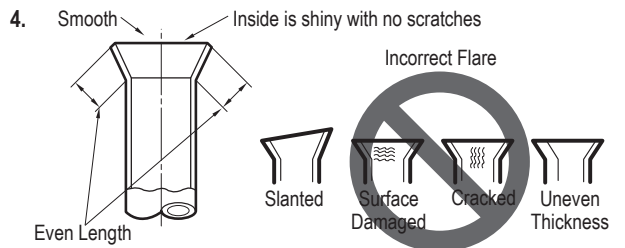

Dimensions of the Flare.

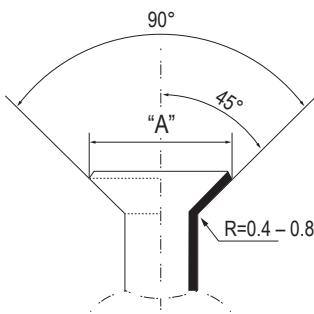

Flared Connection Dimensions / Tightening Torque.

Pipe Size (in. O.D.)	Outside Diameter (mm)	"A" Dimension (mm [in.])
1/4	6.35	~ 9.1 (11/32 - 23/64)
3/8	9.52	~ 13.2 (1/2 - 33/64)
1/2	12.7	~ 16.6 (41/64 - 21/32)
5/8	15.88	~ 19.7 (49/64 - 25/32)
3/4	19.05	-

FLARING AND BRAZING PROCEDURES

Tightening the Flare Nuts

Tightening Torque for Flare Nuts.

Pipe Size (in. O.D.)	Outside Diameter (mm)	Tightening Torque (ft.-lbs.)
1/4	6.35	13.0 - 18.0
3/8	9.52	24.6 - 30.4
1/2	12.7	39.8 - 47.7
5/8	15.88	45.4 - 59.3
3/4	19.05	71.5 - 87.5

1. When connecting the flare nuts, coat the flare (outside only) with polyvinyl ether (PVE) refrigeration oil only.

Note:

- ⊘ Do not use polyolylester (POE) or any other type of mineral oil as a thread lubricant. These lubricants are not compatible with the PVE oil used in this system and create oil sludge leading to equipment damage and system malfunction.
- ⊘ Do not add any contaminants inside the refrigerant piping.

2. Initially hand tighten the flare nuts using three (3) or four (4) turns.
3. To finish tightening the flare nuts, use both a torque wrench and a backup wrench.
4. After all the piping has been connected and the caps have been tightened, check for refrigerant gas leaks.

Loosening the Flare Nuts

Always use two (2) wrenches to loosen the flare nuts.

Brazing Practices

⚠ WARNING

⊘ Do not braze in an enclosed location. ⊘ Do not allow the refrigerant to leak during brazing. Always test for gas leaks before and after brazing.

If the refrigerant combusts, it generates a toxic gas that will cause physical injury or death.

1. Joints are brazed in the field. Single Zone refrigeration system components contain very small capillary tubes, small orifices, electronic expansion valves, oil separators, and heat exchangers that can easily become blocked. Proper system operation depends on the installer using best practices and utmost care while assembling the piping system.
2. Store pipe stock in a dry place; keep stored pipe capped and clean.
3. Blow clean all pipe sections with dry nitrogen prior to assembly.
4. Always use a non-oxidizing material for brazing. ⊘ Do not use flux, soft solder, or anti-oxidant agents. If the proper material is not used, oxidized film will accumulate and clog or damage the compressors. Flux can harm the copper piping or refrigerant oil.
5. Use a tubing cutter, ⊘ do not use a saw to cut pipe. De-bur and clean all cuts before assembly.
6. Brazing joints:
 - Use a dry nitrogen purge operating at a minimum pressure of three (3) psig and maintain a steady flow.
 - Use a 15% silver phosphorous copper brazing alloy to avoid overheating and produce good flow.
 - Protect isolation valves, electronic expansion valves, and other heat-sensitive control components from excessive heat with a wet rag or heat barrier spray.

Figure 31: Refrigerant Pipe Brazing.

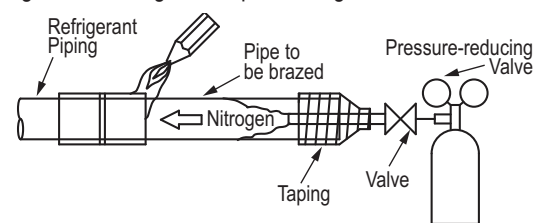

⚠ WARNING

- ⊘ Do not allow the refrigerant to leak during brazing; if the refrigerant combusts, it generates a toxic gas. There is risk of fire, explosion, and physical injury or death.
- ⊘ Do not braze in an enclosed location, and always test for gas leaks before / after brazing. There is risk of fire, explosion, and physical injury or death.

REFRIGERANT PIPING

Installation Overview / Special Applications

Installation

Single Zone Four-Way Ceiling-Cassette systems are one-to-one systems. There is a direct piping connection between the outdoor unit and the indoor unit. The majority of installations have the indoor unit being installed at a higher position than the outdoor unit. However, if the outdoor unit be installed at a higher position than the indoor unit, the basic pipe connections are the same (see below). Refer to the tables in the "Connection Limitations" section for specific length limitations in conjunction with outdoor unit and indoor unit positioning.

NOTE

- When proceeding with piping connections, follow pipe support spacing lengths as shown in the "General Refrigerant Piping System" Information section. Refer to the "Pipe Supports" section for information on using clamps and pipe support materials.
- Always follow local codes regarding piping and accurate support spacing along the piping system.
- Always include insulation on all refrigerant and drain piping to ensure condensate does not form and cause damage to walls, floors, etc.

Special Applications

If an additional drain hose is necessary, the end of drain outlet must be routed above the ground. Secure the drain hose appropriately.

When the Outdoor Unit is Installed Below the Indoor Unit:

1. Use a conduit, piping set cover, or bundle the (separately) insulated refrigerant piping, the drain hose, and the communications / connection (power) cable together.
2. Make sure to include some slack in the wiring. Wiring must be installed in an upwards direction to prevent water from accessing into the control box.
3. Secure the conduit, piping set cover, or bundle along the outside wall using saddles or a similar type of piping support.
4. Seal any openings in the wall that are around the piping.

When the Outdoor Unit is Installed Above the Indoor Unit:

1. Use a piping set cover, or bundle the (separately) insulated refrigerant piping and the communications / connection (power) cable together up to the outdoor unit service valves.
2. Make sure to include some slack in the wiring. Wiring must be installed in upwards direction to prevent water from accessing the control box.
3. If necessary, secure the piping set cover or bundle along the outside wall using saddles or a similar type of piping support.
4. Ensure the drain hose from the indoor unit is installed away from the outdoor unit, and in a downward direction. If necessary, secure along the outside wall using saddles or a similar type of support.
5. Seal any openings in the wall that are around the piping.

Note:

For information about bundling, see the Bundling page in this section. For information about using a conduit to protect the wiring between the outdoor unit and the indoor unit, see the in the Electrical System Installation section.

Figure 32: Special Applications. (For Illustrative Purposes. Appearance and Connection Locations Will Differ Depending On Outdoor Unit Model.)

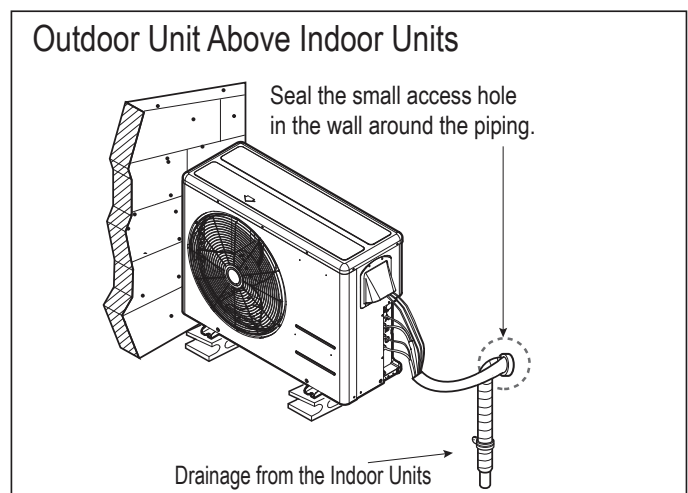
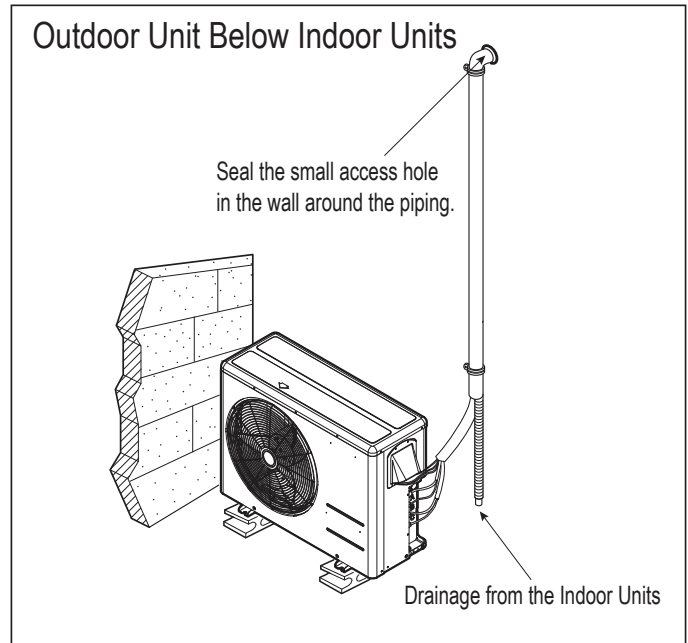

REFRIGERANT PIPING

Outdoor Unit Connections

Optional Piping Routes for LUU360HV and LUU420HV

The piping for LUU360HV and LUU420HV outdoor units can be installed in one of four directions: front, rear, right, and bottom. Whatever direction is chosen, plug the access holes with field-provided putty or insulation to fill all gaps.

If the piping is installed in the bottom direction, the access hole of the base pan must be knocked out before piping work begins.

⚠ WARNING

Insects or small animals entering the outdoor unit may cause a short circuit in the electrical box, which may lead to fire, electric shock, physical injury, or death.

⚠ NOTE

Insects or small animals entering the outdoor unit may cause a short circuit in the electrical box, which may lead to unit failure.

Figure 33: LUU360HV and LUU420HV Outdoor Unit Refrigerant Piping Connection Options.

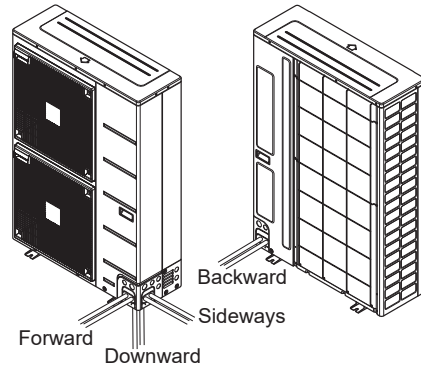
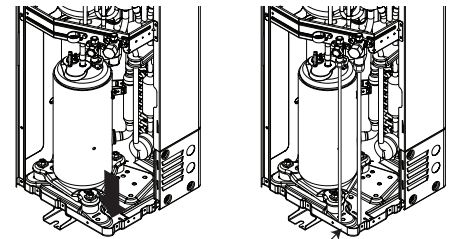
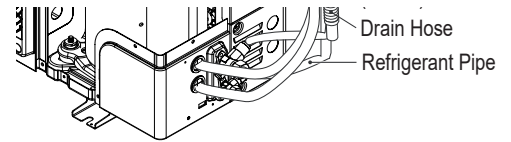

Figure 34: Removing the Base Pan Knock Out Hole.



Access Hole Knock Out for Liquid / Gas Piping

Figure 35: Filling Access Holes in the Outdoor Units.



Outdoor Unit Connection Installation

1. Remove the piping cover and / or piping / control box cover (configuration depends on outdoor unit model) from the unit by loosening the fastening screws.
2. Refer to the figures below for liquid and gas (vapor) piping attachments onto the outdoor unit.
3. Remove the flare nuts attached to the outdoor unit valves.
4. Thread the flare nuts onto the field-supplied piping.
5. Flare the end of the piping following the information in the "General Refrigerant Piping System" section and industry best practices.
6. Place a couple of drops of PVE refrigerant oil on outside of the flare before assembling. ⚠ Do not add any contaminants.
7. Align the center of the refrigerant piping and corresponding connection as shown below and on the next page.
8. Connect the field piping to the outdoor unit connection. Tighten the flare nut initially by hand.
9. Finish tightening the flare nut with a torque wrench until the wrench clicks. Follow torque guidelines in the table on the next page. See figures for correct connection points.

Figure 36: LUU090HV, LUU120HV, LUU180HV, and LUU240HV Piping / Control Box Cover Removal (Appearances Will Differ Depending on Model).

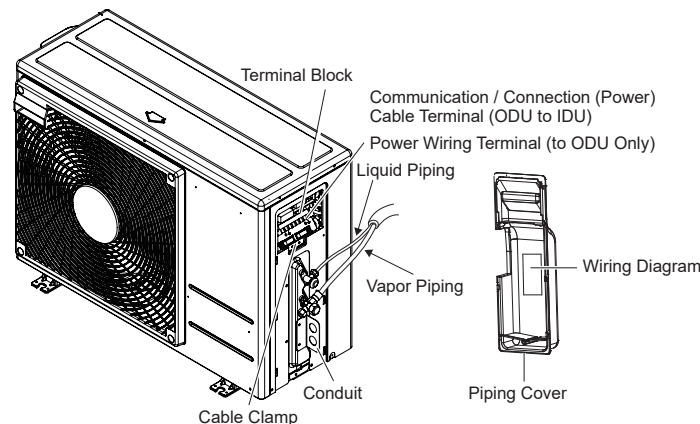
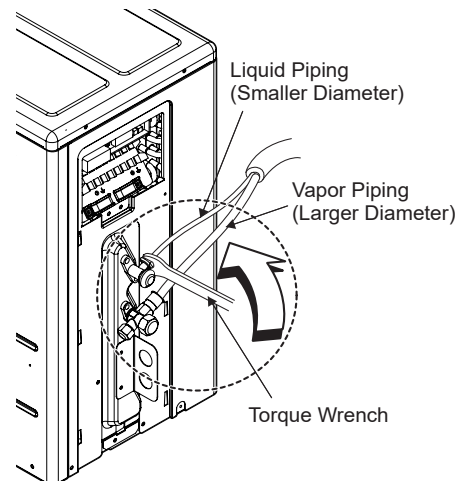

Figure 37: LUU090HV, LUU120HV, LUU180HV, and LUU240HV Piping Connections (Appearances Will Differ Depending on Model).



REFRIGERANT PIPING

Outdoor Unit Connections

Figure 38: LUU360HV and LUU420HV Piping Connection Location.

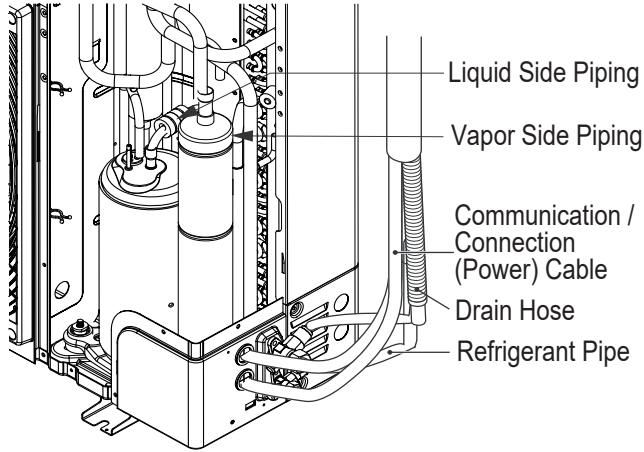

Figure 39: LUU360HV and LUU420HV Connecting the Piping.

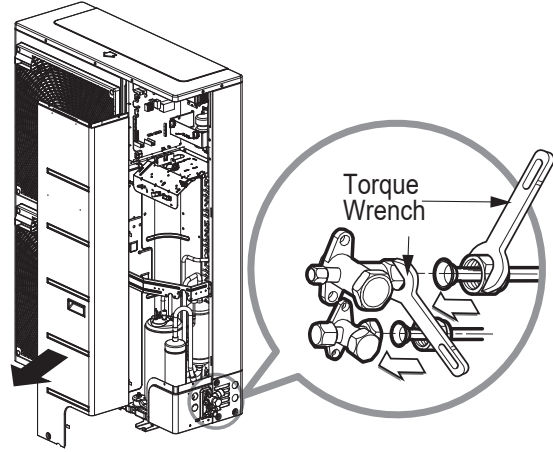

Figure 40: Removing the Flare Nuts on the Outdoor Unit.

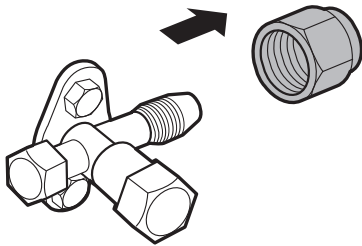

Figure 41: Connecting the Flared Field Piping to the Outdoor Unit Connection.

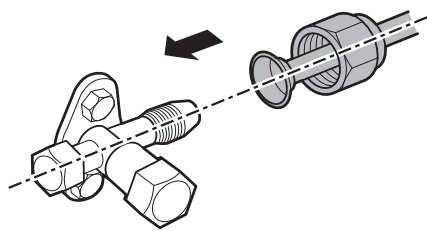

Table 22: Torque Wrench Tightening.

Pipe Size (in. O.D.)	Outside Diameter (mm)	Torque (ft-lbs.)
1/4	6.35	13.0 - 18.0
3/8	9.52	24.6 - 30.4
1/2	12.7	39.8 - 47.7
5/8	15.88	45.4 - 59.3
3/4	19.05	71.5 - 87.5

Note:

- When tightening the flare nut with a torque wrench, ensure the direction for tightening follows the arrow on the wrench.
- To prevent insects or small animals from entering and damaging interior components, plug gaps / access holes with field-supplied putty or insulation.

REFRIGERANT PIPING

Indoor Unit Connections

Indoor Unit Piping Installation

Note:

See the *Electrical System Installation* section for information on how to connect the communication / connection (power) wiring from the outdoor unit.

1. Remove the flare nuts attached to the indoor unit piping. To remove, hold onto the piping with an adjustable wrench, and then loosen the flare nut with a torque wrench.
2. Thread the flare nuts onto the field-supplied piping.
3. Flare the end of the piping following industry best practices, and the information in the "General Refrigerant Piping System" section.
4. Place a couple of drops of PVE refrigerant oil on outside of the flare before assembling. ⚠ Do not add any contaminants.
5. Align the center of the refrigerant field piping to the corresponding indoor unit piping.
6. Connect the refrigerant field piping to the indoor unit piping. First, hold onto the piping with an adjustable wrench. Tighten the flare nut initially by hand, and then finishing tightening using a torque wrench. Follow torque guidelines in the table.

Figure 42: Indoor Unit Connection.

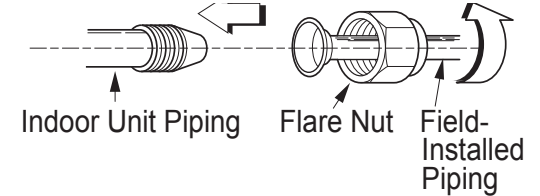

Table 23: Torque Wrench Tightening.

Pipe Size (in. O.D.)	Outside Diameter (mm)	Torque (ft-lbs.)
1/4	6.35	13.0 - 18.0
3/8	9.52	24.6 - 30.4
1/2	12.7	39.8 - 47.7
5/8	15.88	45.4 - 59.3
3/4	19.05	71.5 - 87.5

Note:

When tightening the flare nut with a torque wrench, ensure the direction for the tightening follows the arrow on the wrench.

7. If bundling the refrigerant piping, the drain piping, and communication / connection (power) together, ensure that the drain piping is located at the bottom of the bundle.
- If using a conduit for the power wiring / communications cable, see next page.

Note:

Positioning the drain hose at the top of the bundle can cause condensate to overflow from the inside of the indoor unit.

18,000 Btu/h Ceiling-Cassette Indoor Unit to 18,000 Btu/h Single-Zone Outdoor Unit Refrigerant Piping Connections

The 18,000 Btu/h ceiling-cassette indoor unit requires connectors to be used with 18,000 Btu/h single zone outdoor units. The connectors listed below are included with the 18,000 Btu/h indoor unit. Follow piping installation and torque tightening procedures above when installing the connectors.

Table 24: Refrigerant Connection Piping Sizes.

Outdoor Unit Type	Capacity (Btu/h)	Refrigerant Connection Piping Sizes	
		Liquid	Gas
Single Zone	18,000	3/8 (Ø9.52)	5/8 (Ø15.88)

Table 25: Included 18,000 Btu/h Cassette Connectors.

Connectors (included only for single-zone system installations)	
	One (1) Each for Ø3/8 inch → Ø1/2 inch
	One (1) Each for Ø5/8 inch → Ø1/2 inch
	One (1) Each for Ø1/4 inch → Ø3/8 inch

Figure 43: 18,000 Btu/h Cassette Connector Connections.

For Single Zone Cassette Unit Connection to Single Zone Outdoor Units

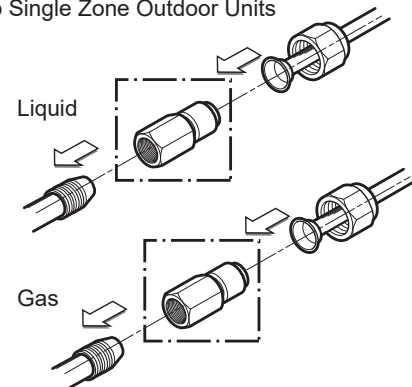

CONDENSATE PIPING

Outdoor Unit Condensate Piping / Indoor Unit Condensate Piping

Outdoor Unit Condensate Drain Piping

Outdoor unit requires condensate drain piping. Condensate drain pipe is constructed with materials approved by federal, state, and local codes. See the "Placement Considerations" section for information in reference to outdoor unit placement.

Indoor Unit Drain Piping Installation

- Any holes through the ceilings, walls etc., must be large enough to accommodate the drain piping and insulation. (See the Insulation section for more information. See also local, state, and federal codes.)
- The unit uses a drain pump with a height of up to 27-9/16 inches to remove condensate. To ensure proper drainage, the factory-supplied flexible drain hose and any field-supplied drain piping must be installed below the maximum height.
- Install any drain lift piping at a right angle to the indoor unit, and no more than 11-13/16 inches (300mm) from the unit.
- Field-supplied drain piping must have downward gradient away from the unit of at least 1/50 to 1/100. To prevent reverse flow, do not vertically slope the drain piping.
- Route the flexible drain pipe to the indoor unit, connect the flexible drain pipe to the indoor unit drain port, and then connect the flexible drain pipe to the field-supplied drain piping.
- When connecting the flexible drain hose or field-supplied drain piping, do not damage the drain port on the indoor unit.
- Dimensions on the indoor unit drain connection is 1-1/4 inches (32mm) outside diameter.
- Piping material: polyvinyl chloride VP25 pipe and pipe fittings.
- After drain hose is installed and tested, insulate with polyethylene foam more than 0.3 inches (8mm) thick (check local, state, and federal codes). Position snugly against the indoor unit frame.

NOTE

The supplied flexible drain hose must not be installed with a sharp curve or twist. A curved or twisted flexible hose will become damaged due to vibration and / or leak.

Figure 44: Drain Piping Installation Specifications.

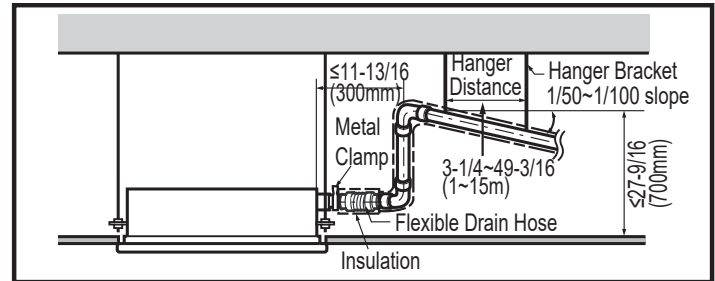
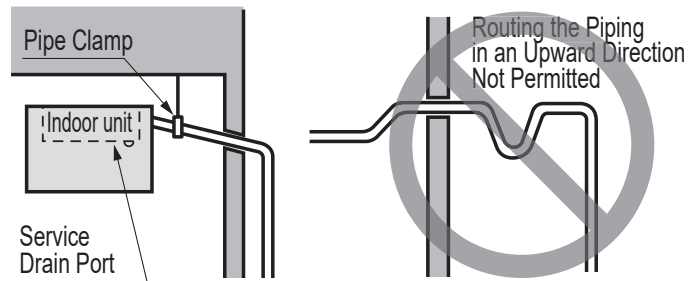

Figure 45: Do Not Route the Piping Upward.



CONDENSATE PIPING

Checking for Leaks / Bundling

Checking the Indoor Unit and Drain Piping for Leaks

To test the flexible drain hose and field-supplied drain piping:

- Connect the flexible drain hose to the field-supplied drain piping (that drains to the outside).
- Pour water into the flexible drain hose and check for leaks.
- Repair any leaks if necessary.

To test the evaporator:

- Remove air filter, if present.
- Connect the flexible drain hose to the indoor unit drain port.
- Spray one (1) or two (2) glasses of water on the evaporator. Verify the water flows out of the drain hose without leaks.
- Repair any leaks if necessary.
- After power wiring installation is complete, operate the drain pump to see if it sounds and functions properly.

Bundling

If a conduit or piping set cover is not used on the connection from the outdoor unit to the interior, bundle both separately insulated refrigerant pipes, the drain hose, and outdoor unit to indoor unit communication / connection (power) cable together with wide vinyl tape.

1. Both piping must be fully and separately encased in insulation material: Overlap the field installation piping insulation material and the indoor unit piping insulation material. Verify that any insulation material cutting lines are placed upward.
2. Bind together the two pipes, using narrow vinyl tape. Make sure there are no gaps during the binding.
3. Continue to wrap the indoor unit pipe as connected to the outdoor connection pipe.
4. Using a wider vinyl tape, bundle the piping and drain hose together, if applicable. Install the wider vinyl tape from the bottom up.
 - Tape must be sufficient to cover the piping in order to fit into the rear piping housing area at the back of the indoor unit.

NOTE

- Always include insulation on all refrigerant and drain hose to ensure condensate does not form and cause damage to walls, floors, etc.
- Positioning the drain hose at the top of the bundle can cause condensate to overflow from the drain pan in the inside of the indoor unit.

Figure 46: Checking the Drain Piping.

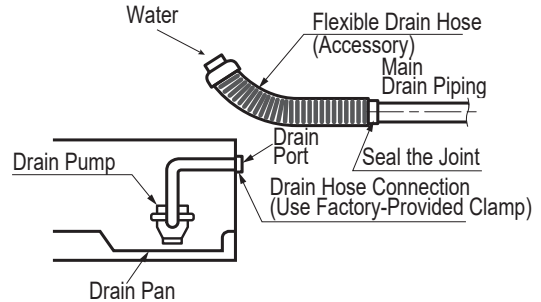

Figure 47: Bundling the Connection Components (From Outdoor Unit to Indoor Unit).

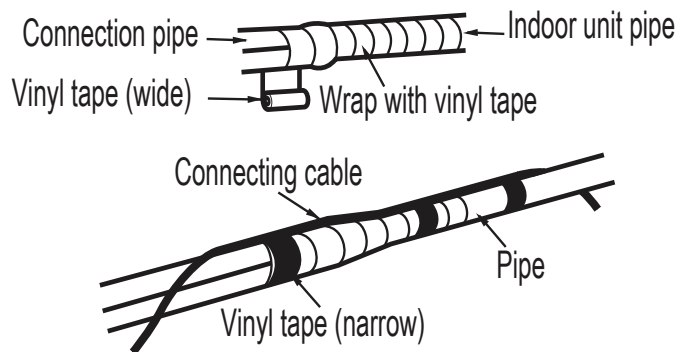

Figure 48: Cut Line Position.

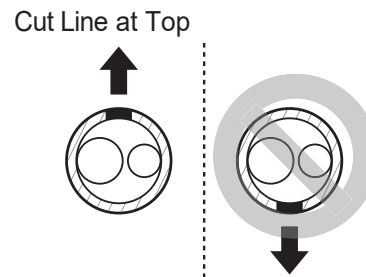
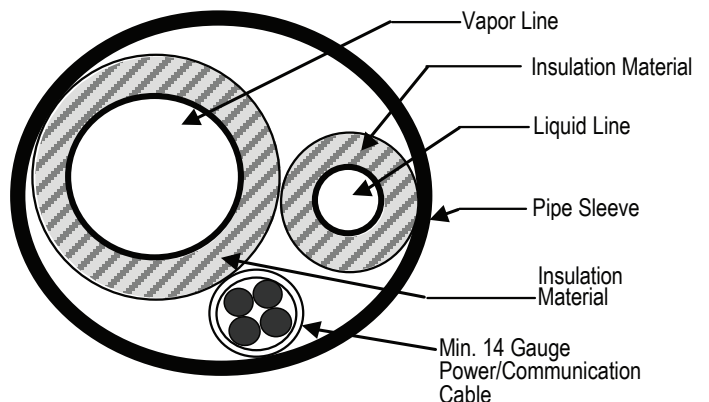

Figure 49: Cutaway of Proper Pipe and Cable Bundling.



INSULATION

Refrigerant Piping System Insulation

Note:

For information regarding insulation for underground or penetration situations, see the “General Refrigerant Piping System Information” section.

All refrigerant piping from the outdoor unit to the indoor units must be insulated correctly for safety and usage. Refrigerant piping, field-provided isolation ball valves (if present), service valves, and elbows must be properly and completely insulated using closed cell pipe insulation (up to the indoor unit piping connections). To prevent heat loss / heat gain through the refrigerant piping, all refrigerant piping including liquid lines and vapor lines must be insulated separately. Insulation must be a minimum 1/2 inches thick, and thickness will need to be increased based on ambient conditions and local codes. Table on next page lists minimum wall thickness requirements for Ethylene Propylene Diene Methylene (EPDM) insulation.

Inside the outdoor unit, maximum pipe temperature is 248°F and minimum pipe temperature is -40°F. For field insulation of refrigerant piping between outdoor units and indoor units, consider the following pipe temperature ranges for an operating heat pump system:

- Heating mode refrigerant temperature ranges: Liquid = 75-118°F; High Pressure Vapor = 95-220°F
- Cooling mode refrigerant temperature ranges: Liquid = 75-118°F; Low Pressure Vapor = 40-90°F

All insulation joints must be glued with no air gaps. Insulation material must fit snugly against the refrigeration pipe with no air space between it and the pipe. ⚠ Do not allow insulation passing through pipe hangers, inside conduit, and/or sleeves to be compressed. Protect insulation inside hangers and supports with a second layer. All pipe insulation exposed to the sun and outdoor elements must be properly protected with PVC, aluminum vapor barrier, or alternatively placed in a weather-resistant enclosure such as a pipe rack with a top cover; and meet local codes.

Figure 50: Typical Insulation Butt-Joint at Indoor Unit Casing.

Figure 51: Typical Refrigerant Flare Fitting Insulation Detail.

Figure 52: Close Up of Typical Insulation at the Indoor Unit.

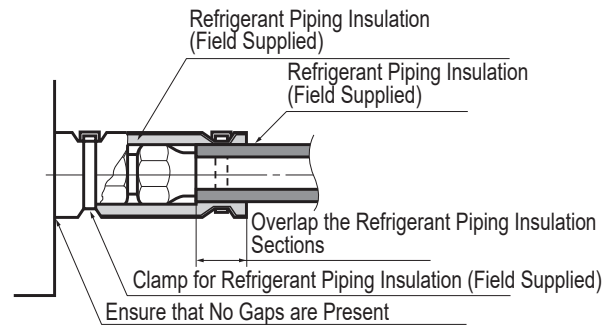
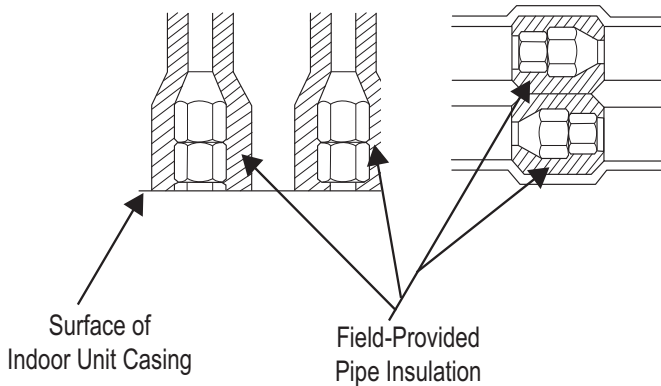
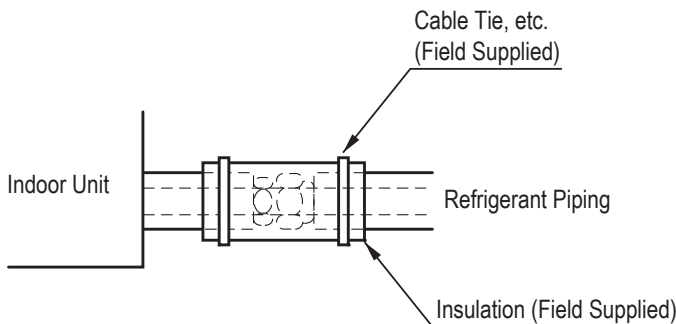

Figure 53: Insulating the Shut Off / Insulation Ball Valve (If Present).



NOTE

Always include plenty of insulation on all refrigerant and drain piping to ensure condensate does not form and cause damage to walls, floors, etc.

Minimum Refrigerant Pipe Ethylene Propylene Diene Methylene (EPDM) Insulation Wall Thickness Requirements

Note:

- Ⓞ Do not insulate gas and liquid pipes together as this can result in pipe leakage and malfunction due to extreme temperature fluctuations.
- Always properly insulate the piping. Insufficient insulation will result in condensation, reduced heating/cooling performance, etc. Also, if the pipes aren't insulated properly, condensation could potentially cause damage to building finishes. Pay special attention to insulating the pipes installed in the ceiling plenum.
- Fully insulate the piping connections.
- Follow local codes and the designer's instructions when selecting ethylene propylene diene methylene (EPDM) insulation wall thickness.

Table 26: Minimum Refrigerant Pipe EPDM Insulation Wall Thickness Requirements.¹

Classification / Piping O.D.		Air-conditioned location		Non-air conditioned location	
		1. Typical Conditioned Location	2. Special Conditioned Location	3. Typical Unconditioned Location	4. Special Unconditioned Location
Liquid pipe	ø1/4 inch	>1/2 inches	>1/2 inches	>1/2 inches	>1/2 inches
	ø3/8 inch				
	≥ø1/2 inch				
Vapor pipe	ø3/8 inch	>1/2 inches	>3/4 inches	>3/4 inches	>1 inch
	ø1/2 inch				
	ø5/8 inch				
	ø3/4 inch				
	ø7/8 inch				
	ø1 inch	>3/4 inches	>1 inch	>1 inch	
	ø1-1/8 inches				
	ø1-1/4 inches				
	ø1-3/8 inches				
	ø1-1/2 inches				
ø1-3/4 inches					

¹The thickness of the above insulation material is based on heat conductivity of 0.61 Btu/in/h/ft²/°F.

1. Typical Conditioned Location

A building plenum or space that contains conditioned air that does not exceed 80°F DB.

2. Special Conditioned Location

1. When the location is air conditioned, but there is severe temperature/humidity difference due to high ceilings.
 - Church, auditorium, theater, lobby, etc.
2. When the location is air conditioned, but internal temperature/humidity are high.
 - Bathroom, swimming pool, locker room, etc.

3. Typical Unconditioned Location

An unconditioned space inside a building.

4. Special Unconditioned Location: If conditions 1 and 2 below are present.

1. An unconditioned space or plenum of a building.
2. An area where there is an elevated humidity level.

5. Additional Insulation for Indoor Units May be Required in Humid Environments.

The air conditioner factory insulation has been tested according to "ISO Conditions with Mist," and it satisfies the requirements. If the system has been operating for a long time in a high humidity environment (dew point temperature: more than 73°F), condensate is likely to form. If this happens, install 3/8 inch thick EPDM insulation that is plenum-rated with a heat-resistance factor of more than 248°F.

ELECTRICAL SYSTEM INSTALLATION

Safety Guidelines / Connections and Specifications

⚠ WARNING

- All power wiring and communication cable installation must be performed by trained service providers working in accordance with local, state, and National Electrical Code (NEC) / UL / ETL federal regulations related to electrical equipment and wiring, and following the manufacturer product diagrams, requirements, and instructions in this manual. Failure to do so will lead to electric shock which can cause physical injury or death.
- Verify that main power to the unit is completely off before proceeding. Follow all safety and warning information outlined at the beginning of this manual. Failure to do so will cause electric shock and bodily injury or death.
- Familiarize yourself with the location of the circuit breaker. Be sure that a circuit breaker or some other emergency power cutoff device is in place before any power wiring is done to the system. Failure to do so will cause bodily injury or death.
- ⚡ Never touch any power lines or live cables before all power is cutoff to the system. To do so will cause bodily injury or death.
- Undersized wiring will lead to unacceptable voltage at the unit and will cause a fire, which will cause bodily injury or death.
- Properly ground the Single Zone outdoor and indoor units. Ground wiring is required to prevent accidental electrical shock, bodily injury, and death during current leakage.
- Ground wiring must always be installed by a trained technician.
- Install appropriately sized breakers / fuses / overcurrent protection switches and wiring in accordance with local, state, and NEC regulations related to electrical equipment and wiring, and following the instructions in this manual. Using an oversized breaker or fuse will result in electric shock, physical injury or death.
- ⚡ Do not connect ground wire to refrigerant, gas, or water piping; to lightning rods; to telephone ground wiring; or to the building plumbing system. Failure to properly provide a NEC-approved earth ground can result in electric shock, fire, physical injury or death.

⚠ NOTE

- Consider ambient conditions (temperature, direct sunlight, inclement weather, etc.) when selecting, installing, and connecting the power wiring.
- Properly ground the Single Zone outdoor and indoor unit. Improperly connected ground wire can cause communication problems from electrical noise and motor current leakage. Ground wiring must always be installed by a trained technician.
- Install appropriately sized breakers / fuses / overcurrent protection switches and wiring in accordance with local, state, and NEC regulations related to electrical equipment and wiring, and following the instructions in this manual. Using an oversized breaker or fuse will result in equipment malfunction and property damage.
- ⚡ Do not connect ground wire to refrigerant, gas, or water piping; to lightning rods; to telephone ground wiring; or to the building plumbing system. Failure to properly provide a NEC-approved earth ground can result in property damage and equipment malfunction.
- ⚡ Do not operate the air conditioning system until the refrigerant piping installation is complete. Operating the system before refrigerant piping is finalized will damage the compressor.

Power Wiring / Communication Cable Connections

Best practice dictates using solderless ring or fork terminals at all power wiring and communication cable terminations. Use copper bearing ring or fork terminals; ⚡ do not use galvanized or nickel plate over steel. Use appropriate crimping tool to attach the ring or fork terminals at all power wiring and control cable terminations.

To Install a Ring or Fork Terminal:

1. Trim the wiring with wire cutters or pliers, then strip the insulation to expose the strand wiring to about 3/8 inches.
2. Using a ring terminal fastener or pliers, securely clamp a ring terminal to each stripped wire end.

Figure 54: Close up of a Typical Ring Terminal.

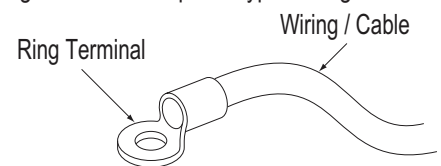
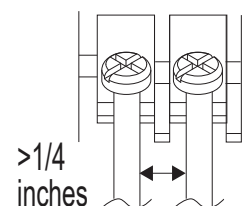

Figure 55: Distance Between the Terminal Connections.



ELECTRICAL SYSTEM INSTALLATION

Connections and Specifications

Power Wiring / Communication Cable Connections, continued

To Connect the Wiring to the Terminals:

1. Remove the JIS terminal screws from the (outdoor unit or indoor unit) terminal plate with a JIS screwdriver. (See information about LG terminal connections below.)
2. Position the ring terminal around the terminal, place the terminal screw in the ring, and tighten to the terminal plate using a JIS screwdriver.
 - Firmly attach the wire; secure in a way to prevent external forces from being imparted to the terminal block.
 - Use an appropriately sized JIS screwdriver for tightening the terminals.
 - ⚠ Do not over tighten the connections; over tightening will damage the terminals.

Figure 56: Adding a Ring Terminal to the Wiring.

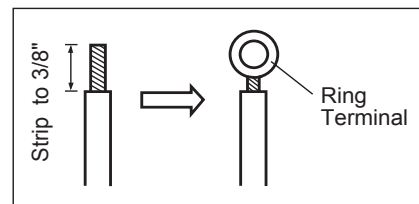

If ring terminals or fork terminals are not available, then:

- ⚠ Do not terminate different gauge wires to the power terminal block. (Slack in the wiring will generate heat.)
- When terminating wires of the same thickness, follow the instructions demonstrated in the figures below.

Figure 57: Tightening the Ring Terminal to the Terminal Plate.

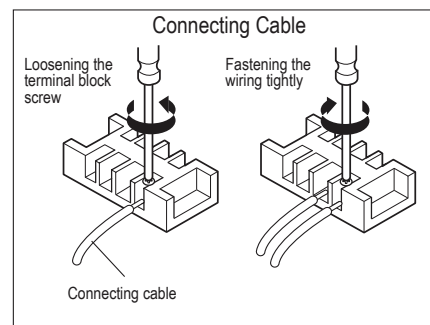

⚠ WARNING

If power wires are not properly terminated and firmly attached, there is risk of fire, electric shock, and physical injury or death.

⚠ NOTE

- ⚠ Never apply line voltage power to the communications cable terminal block. If contact is made, the PCBs will be damaged.
- Always include some allowance in the wiring length when terminating. Firmly attach the wiring or cable, but provide some slack to facilitate removing the electrical panels while servicing, and to prevent external forces from damaging the terminal block.

Figure 58: Proper and Improper Power Wiring Connections.

● :Copper Wire

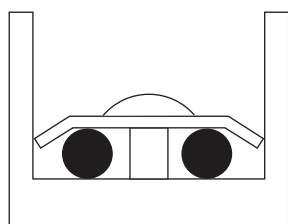

Terminate multiple power wires of the same gauge to both sides.

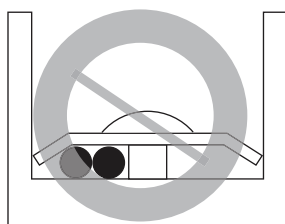

⚠ Do not terminate two wires of one side.

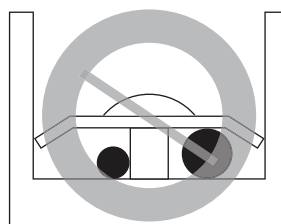

⚠ Do not terminate different gauge wires to a terminal block.

Terminal Connections

LG uses a "JIS" type of screw for all terminals; use a JIS screwdriver to tighten and loosen these screws and ⚠ avoid damaging the terminal. ⚠ Do not over tighten the connections — over tightening will damage the terminals — but firmly and securely attach the wiring in a way to prevent external forces from being imparted to the terminal block.

Note:

- The terminals labeled "GND" are NOT ground terminals. The terminals labeled ⚡ ARE ground terminals.
- Polarity matters. Always connect "A / 1" to "A / 1" and "B / 2" to "B / 2".
- ⚠ Do not include splices or wire nuts in the communication cable.

Figure 59: JIS Screws.

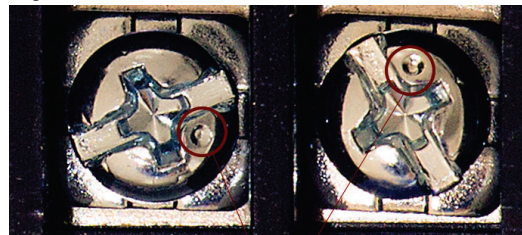

JIS DIMPLES

ELECTRICAL SYSTEM INSTALLATION

Connections and Specifications

Power Supply / Power Wiring Specifications

- Four-way ceiling-cassette systems operate at 1Ø, 208-230V, 60Hz.
- Power wiring / power wiring gauge to the outdoor unit(s) must be solid or stranded, and must comply with all National Electrical Code (NEC), UL, and local electrical codes.
- The indoor unit is powered by the outdoor unit.
- Power supply, wire types and sizes, and circuit breaker must be selected based on NEC, UL, and local codes. Maximum allowable voltage fluctuation $\pm 10\%$ or nameplate rated value.
- Properly ground the outdoor unit and indoor unit per NEC, UL, and local codes.
- Ground wire must be longer than the common power / communication wires.
- Connect the wiring firmly so the wires cannot be easily pulled out.
- Refer to the inside of the chassis cover or control cover for circuit and terminal block diagrams.
- Always match color codes of each wire and follow wiring diagram.
- Ⓞ Do not install power wiring to the outdoor unit and the communication / connection (power) cable from the outdoor unit to the indoor unit in the same conduit. Use separate conduits.

Figure 60: Single Zone Outdoor Unit Power Wiring Diagram.

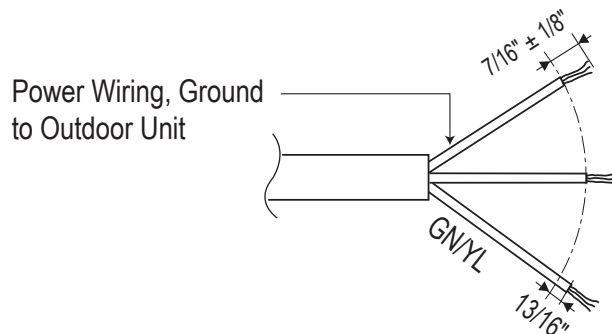

Figure 61: Power Wiring Conduit.



⚠ DANGER

Refer to *Electrical Data* table for ampere ratings. Properly size all circuit breakers / fuses, wiring and field provided components per local codes. There is risk of fire, electric shock, explosion, physical injury or death.

⚠ WARNING

- All power wiring installation must be performed by trained service providers working in accordance with local, state, and NEC regulations related to electrical equipment and wiring, and following the instructions in this manual. Failure to do so will lead to electric shock and bodily injury or death.
- Use specified wiring for connections, and ensure that external force is not imparted to terminal connections. It will generate heat and / or cause a fire, resulting in physical injury or death.
- Use heat-proof electrical wire capable of withstanding temperatures up to 167°F to avoid wiring malfunction and electrical shock, which will cause physical injury or death.
- Install appropriately sized breakers / fuses / overcurrent protection switches and wiring in accordance with local, state, and NEC regulation related to electrical equipment and wiring, and following the instructions in this manual. Generated overcurrent will include some amount of direct current. Using an oversized breaker or fuse will result in electric shock, physical injury or death.
- Use the appropriate type of overcurrent protection. Generated overcurrent will include some amount of direct current, and if the appropriate type of overcurrent protection is not installed, there is a risk of fire, electric shock, and physical injury or death.
- Ground wiring is required to prevent accidental electrical shock during current leakage, communication problems from electrical noise, and motor current leakage. Ⓞ Do not connect the ground line to the pipes. There is risk of fire, electric shock, explosion, physical injury or death.
- Per code, install a main indoor breaker, and an outdoor service disconnect that interrupts all power sources simultaneously. There is risk of fire, electric shock, explosion, physical injury or death.

⚠ NOTE

- If there is a possibility of momentary blackout, or the power goes on and off while the system is operating, install a field-supplied phase loss protection circuit. If not, the compressor and other components will be damaged.
- Use heat-proof electrical wire capable of withstanding temperatures up to 167°F to avoid damage to unit.
- Install appropriately sized breakers / fuses / overcurrent protection switches and wiring in accordance with local, state, and NEC regulations related to electrical equipment and wiring, and following the instructions in this manual. Generated overcurrent will include some amount of direct current. Using an oversized breaker or fuse will result in equipment malfunction and property damage.
- Ⓞ Do not connect ground wire to refrigerant, gas, or water piping; to lightning rods; to telephone ground wiring; or to the building plumbing system. Failure to properly provide a NEC approved earth ground can result in property damage and equipment malfunction.

ELECTRICAL SYSTEM INSTALLATION

Connections and Specifications

Communication / Connection (Power) Cable Specifications from Outdoor Unit to Indoor Unit

- Communication / connection (power) cable from the single zone outdoor unit to the indoor unit must use a minimum of 14 AWG, four (4) conductor, stranded, shielded or unshielded (if shielded, it must be grounded to the chassis of the outdoor unit only), and must comply with applicable local and national codes.
- Use of 14 AWG, four (4) conductor, stranded, shielded or unshielded wire is allowed for lengths up to the published maximum pipe length, plus recommended slack at both ends.
- Insulation material as required by local code.
- Firmly attach the cable; provide slack but secure in a way to prevent external forces from being imparted on the terminal block.
- Wiring must be completed without splices.

Figure 62: Single Zone Outdoor Unit to Indoor Unit Wiring and Communications Cable Diagram.

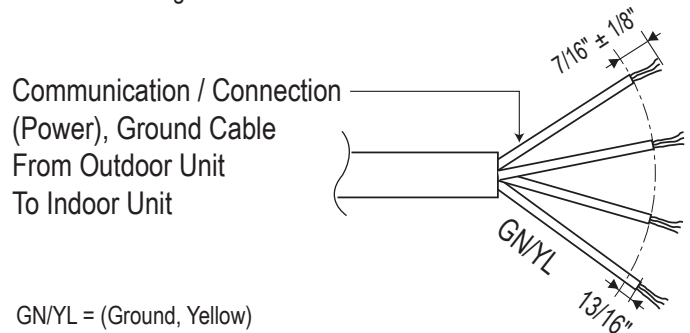

⚠ WARNING

All power wiring and communication cable installation must be performed by trained service providers working in accordance with local, state, and National Electrical Code (NEC) / UL / ETL federal regulations related to electrical equipment and wiring, and following the manufacturer product diagrams, requirements, and instructions in this manual. Failure to do so will lead to electric shock which can cause physical injury or death.

Note:

- Always verify the communication cable is connected to a communications terminal on the Single Zone unit. ⚡ Never apply line voltage power to the communication cable connection. If contact is made, the PCBs will be damaged.
- The shield of the communications cable connecting the outdoor unit to the indoor unit must be grounded only to the outdoor unit frame.
- Tie the shield of each cable segment together using a wire nut at the indoor unit. Maintain polarity throughout the communication network.
- Position the incoming power to the outdoor unit away from the power / communications cables from the outdoor unit to the indoor unit.
- ⚡ Never use a common multiple-core communications cable.

Figure 63: Single Zone Cassette Power / Communication System Diagram (Appearances May Vary Slightly).

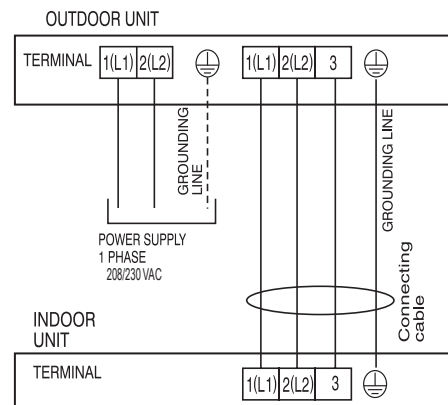

Note:

- Use a conduit for the communications cable / power wiring from the outdoor unit to the indoor units.
- Make sure the communications cable / power wiring from the outdoor unit to the indoor unit, and the power wiring to the outdoor unit are separate, otherwise, the outdoor unit operation will be affected by electrical noise and will malfunction or fail.

ELECTRICAL SYSTEM INSTALLATION

Connections and Specifications / Controller Options

Controller Options

Single Zone Four-Way Ceiling Cassette systems include a wireless handheld remote controller (For 9K, 12K, 18K Systems: Model No. PQWRHQ0FDB; Part No. AKB73757604; For 24, 36, 42K Systems: AKB75735404). Optional LG-supplied wired controllers are available. See “Functions, Controls, Options”, or contact an LG representative for more information.

Wireless Handheld Remote Controller features:

- Display Panel: Displays operation conditions.
- On / Off Buttons: Turns system operation on and off.
- Mode Button: Selects the operation mode: Cooling, Heating, Auto, Dry (Dehumidification), or Fan.
- Temp Up / Down Buttons: Adjusts the desired room temperature in the different modes.
- Fan Speed Button: Sets desired fan speed.
- Reset: Initializes the handheld remote control settings.

Figure 64: PQWRHQ0FDB (AKB73757604) Wireless Handheld Remote Controller.

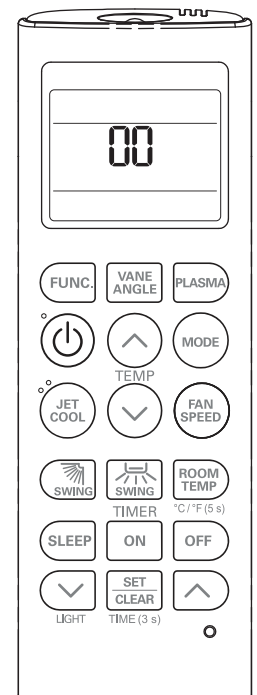

Wired Controller Connections

Optional controllers (see “Functions, Controls, Options” in the engineering manual, or contact an LG representative for more information) can connect to the Four-Way Ceiling Cassette indoor unit in one of two different ways.

1. LG Wired Remote Extension Cable with Molex plug (PZCWRC1; sold separately) that connects to the CN-REMO terminal on the indoor unit PCB.
2. Field-supplied controller cable that connects to the indoor unit terminal block (must be at least UL2547 or UL1007, and at least FT-6 rated if local electric and building codes require plenum cable usage). Communication cable from indoor unit to remote controller(s) is to be 22 AWG, 3-conductor, twisted, stranded, unshielded. Wiring must comply with all applicable local and national codes.

Note:

When using field-supplied controller cable, make sure to connect the yellow to yellow (communications wire), red to red (12V power wire), and black to black (ground wire) terminals from the remote controller to the indoor unit terminal blocks.

Figure 65: PZCWRC1 LG Wired Remote Extension Cable.

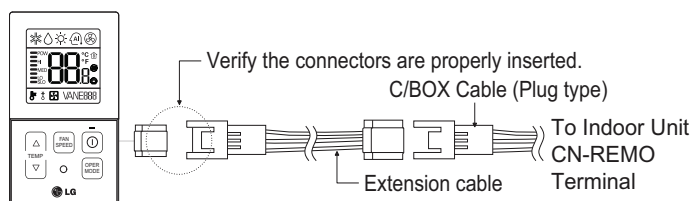
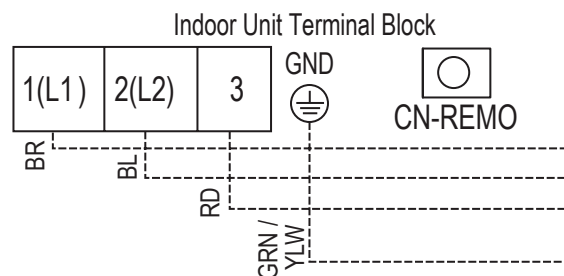

Figure 66: Wired Controller Connection.



ELECTRICAL SYSTEM INSTALLATION

Indoor Unit Electrical Connections

Connecting Indoor Unit Wiring

⚠ WARNING

- Verify that main power to the unit is completely off before proceeding with these steps as there is a risk of electrical shock, bodily injury, and / or death.
- Follow all safety and warning information outlined at the beginning and throughout this manual. Failure to do so will cause electrical shock, bodily injury, and / or death.

Note:

- Follow all safety and warning information outlined at the beginning and throughout this manual. Failure to do so will cause unit failure.
- Connect the communication / connection (power) cable to the indoor unit by matching the terminals on the outdoor unit control board. Verify the color of the wires at the outdoor unit, along with the terminal numbers, match those for the indoor unit.
- Images are representative; actual appearance will vary.
- Refer to the circuit diagram on the indoor unit.

1. If the decoration grille (required; sold separately) has been installed, remove it for easier access to the metal control box. For information on decoration grille installation, see the Final Procedures section.
2. Using a Phillips head screwdriver, remove the metal control box cover by unscrewing the two (2) screws that hold it in place. Set aside the metal control box cover and screws for reattachment.
3. Insert the communication / connection (power) cable (from the outdoor unit to the indoor unit) through its designated access hole in the side of the cassette frame (see images). If using a conduit, attach it to the conduit mounting plate at the access hole, and secure with a lock nut.
4. Using a JIS screwdriver, connect the cable terminals to the terminal block. Ensure wire color and terminal number of the indoor unit matches those of the outdoor unit. Refer to the wiring diagram on the indoor unit.
5. If installing a wired remote controller (optional, sold separately), insert the controller wiring through its designated access hole opposite of the outdoor to indoor cable. Refer to the wiring diagram on the indoor unit.
6. Reinstall the metal control box by reattaching it with its two (2) screws.

Figure 67: Accessing the Control Box / Terminals.

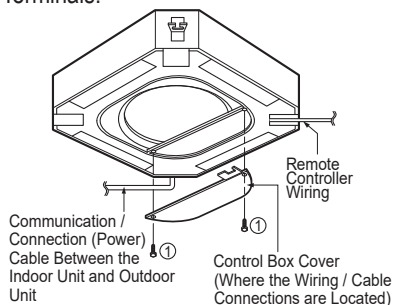
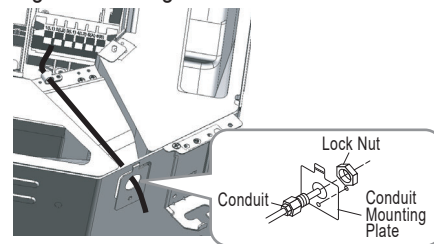

Figure 68: Using a Conduit.



Note:

- Each wire must be securely attached to the terminal block.
- Ground cable must be longer than the other wires.
- Secure the cable onto the control board using a cable tie.
- Use a conduit to protect the cable / refrigerant piping from the indoor unit to the outdoor unit.

Note:

For more information on conduits or the bundling method, see the Refrigerant Piping Connection section.

ELECTRICAL SYSTEM INSTALLATION

Using a Conduit / Outdoor Unit Electrical Connections

Using a Conduit for Indoor Unit Wiring / Cable Installation

Note:

Use a liquidtight 3/4 inch elbow connector for flexible conduit to protect the communication / connection (power) cable.

1. Indoor unit includes a conduit bracket that can be found in the accessory kit. Assemble the conduit and bracket with a grommet and washer (field-supplied or included with the elbow connector).
2. Guide the power wiring / communication cable into the conduit / bracket assembly.
3. Attach the conduit / bracket assembly to the indoor unit using the screws found in the accessory kit.

Note:

Check local, state, and federal codes when choosing a conduit size.

4. To protect the piping, condensate drain, and conduit from the elements, add a lineset cover from the indoor access hole to the outdoor unit.

Note:

If a conduit is not used, see pages in the "Refrigerant Piping Connections" for refrigerant piping, condensate drain, power wiring / communication cable bundling information.

Figure 71: Liquidtight 3/4 Inch Elbow Connector Attached to Flexible Conduit.

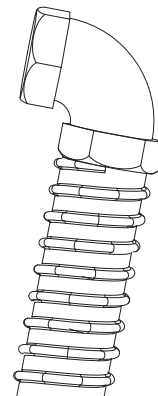

Connecting Outdoor Unit Wiring

⚠ WARNING

- Verify that main power is completely off and that no power is going through the Single Zone system before proceeding with these steps. Follow all safety and warning information outlined at the beginning of this manual. Failure to do so will cause electric shock, bodily injury and / or death.
- Per code, install a main indoor breaker, and an outdoor service disconnect that interrupts all power sources simultaneously. There is risk of fire, electric shock, explosion, physical injury or death.
- Verify that the circuit breaker or some other emergency power cutoff device is in place before any power wiring is done to the system. Failure to do so will cause electric shock, bodily injury and / or death.
- ⚡ Never touch any power lines or live cables before all power is cutoff to the system. To do so will cause bodily injury or death.

1. Using a Phillips head screwdriver, remove the piping / control box cover, side panel and control box cover (depends on model) from the outdoor unit.
2. Inspect all wiring inside the chassis to be sure they are secure and have not loosen during transportation and installation of the outdoor unit. Inspect wires for damage or cracks.

⚠ WARNING

Loose, damaged, or cracked wires will cause electric shock, bodily injury and / or death.

⚠ NOTE

Loose wires can cause the wiring to burn out, damaging the outdoor unit.

Figure 69: Circuit Breaker.

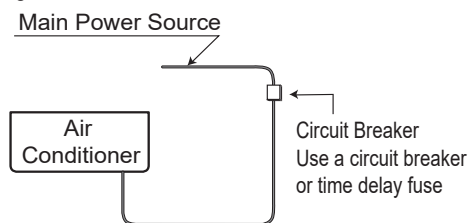
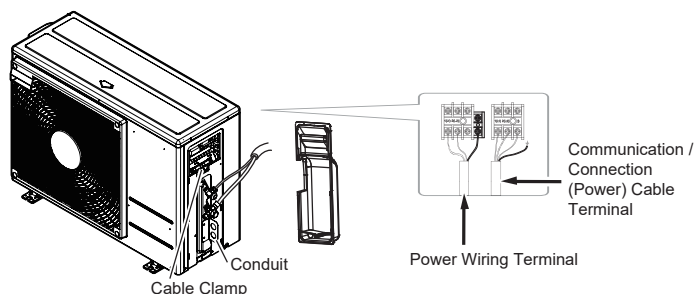

Figure 70: Accessing LUU090-120HV Outdoor Unit Wiring Connections.



ELECTRICAL SYSTEM INSTALLATION

Outdoor Unit Electrical Connections

Connecting Outdoor Unit Wiring, continued.

3. Confirm that electrical power supply capacity will be sufficient to run the unit. Verify that a circuit breaker and service disconnect are installed. See the Electrical table in the Product Data section for details on electrical requirements.

⚠ WARNING

Per code, install a main indoor breaker, and an outdoor service disconnect that interrupts all power sources simultaneously. There is risk of fire, electric shock, explosion, physical injury or death.

4. Confirm that the right gauge size is used for all wiring. Follow all federal, state, and local codes related to wiring.

5. Guide the power wiring to the outdoor unit, and communications / connection (power) cable from the outdoor unit to the indoor unit, through the conduit holes on the outdoor unit or control box cover (see images at right and on the next page). If using rubber bushings, ensure that they are properly installed, or use conduits to protect the wiring and cable.

6. Using a JIS screwdriver, connect wires as shown. See also indoor unit wiring diagram, and outdoor unit wiring diagram on the inside of its chassis cover.

- Each wire must be individually and securely attached to each terminal.

⚠ WARNING

Loose, damaged, or cracked wires will cause electric shock, bodily injury and / or death.

⚠ NOTE

Loose wires can cause the wiring to burn out, damaging the outdoor unit.

- Secure wiring / cables with cable ties.
- Pay attention to the location / connection of the ground cable.
- Maintain a minimum of 1/4 inches of wire length from terminal block to cable bundle.

7. When finished, reattach the piping / control box cover or side panel / control box cover (depends on model) to the outdoor unit with the screws.

Figure 72: Accessing LUU180-240HV Outdoor Unit Wiring Connections.

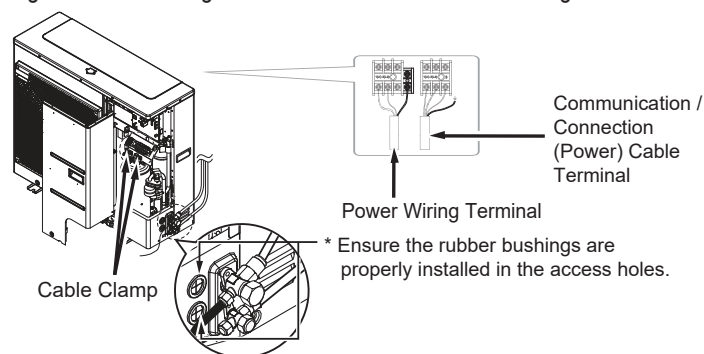

Figure 73: Accessing LUU360-420HV Outdoor Unit Wiring Connections.

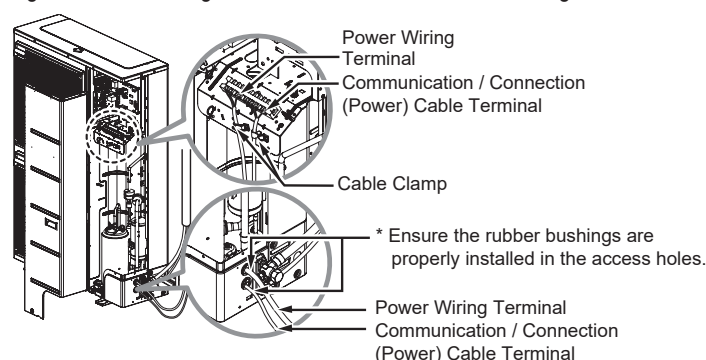

Figure 74: Example of Conduit.



Note:

⊘ Do not install power wiring to the outdoor unit and the communication / connection (power) cable to the indoor unit in the same conduit. Use separate conduits. Communication problems will occur.

Figure 75: Outdoor Unit Electrical Connections.

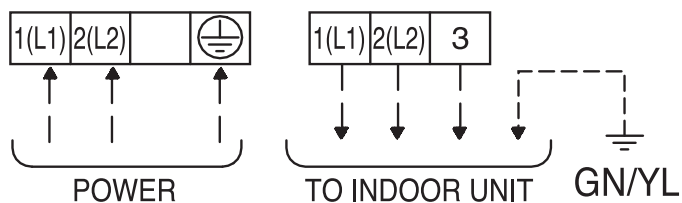

FINAL INSTALLATION PROCEDURES

Triple Leak / Pressure Test

Triple Leak / Pressure Test

After the refrigerant piping installation is complete, perform a triple leak / pressure test. Triple leak / pressure test is performed between the outdoor unit and indoor unit to verify that refrigerant can flow through the system without danger of leaks or pressure losses. Air and moisture that is left in the piping can lead to undesirable results and can cause damage to the system. It is important to go through a complete leak / pressure cycle to be sure that the refrigerant piping is cleared out. This process will have to be repeated if any air or moisture be is found to remain in the piping.

Note:

Insufficient or incorrectly done air purging will lead to the following:

- Pressure in the system can rise.
- Operating current can rise.
- Inefficient cooling or heating mode capability.
- Moisture in the refrigerant circuit will freeze and block capillary tubing.
- Water can lead to corrosion of parts in the system.

⚠ DANGER

Using combustible gases, including oxygen will result in fire or explosion, resulting in personal injury or death. Use inert gas (medical-grade dry nitrogen) when checking leaks, cleaning, installing/repairing pipes, etc. The use of a 800 psig nitrogen regulator is required for safety.

Note:

- ⓧ Never perform the leak test using refrigerant.
- ⓧ To avoid nitrogen entering the refrigerant system in a liquid state, the top of the cylinder must be higher than its bottom (used in a vertical standing position) when the system is pressurized.
- Use only a leak-free gauge manifold set.
- Piping system must not be pressured to more than 550 psi. Pressures greater than 550 psi will damage the piping system and cause unit malfunction.

Triple Leak / Pressure Check Procedure

1. After the refrigerant piping installation is complete, open the isolation ball valves, if any, that may have been included in the piping system.
2. Verify that both the liquid and gas (vapor) suction line outdoor unit service ports are closed, and the stem head access caps are tight. The leak / pressure check is to be performed only to the refrigerant piping system and the connected indoor unit.
3. Remove the cap on the gas (vapor) suction line Schrader port. Connect the (medical-grade dry) nitrogen cylinder regulator to a gauge manifold, then connect the gauge manifold to the gas (vapor) suction Schrader port on the service port.
4. Perform the leak / pressure check at 150 psig for fifteen (15) minutes (standing pressure check).
5. Perform the leak / pressure check at 300 psig for thirty (30) minutes (standing pressure check).
6. Perform the leak / pressure check at 550 psig for one (1) hour to make sure the piping system is leak-free. After the gauge reading reaches 550 psig, isolate the system by first closing the gauge manifold, then close the nitrogen cylinder valve. Check the flared (and any brazed connections) for leaks by applying a bubble solution to all joints.

Note:

The bubble solution must be a solution designed for refrigerant leak testing. Common soap solution must ⓧ never be used on refrigerant piping as those contain chemicals that could corrode copper and brass, and cause product malfunction.

Figure 76: Example of Outdoor Unit Service Valves. (Appearances Will Vary Depending on Model.)

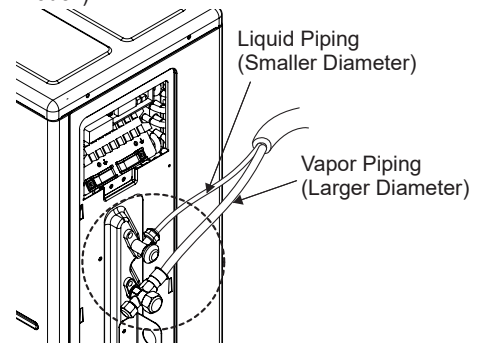
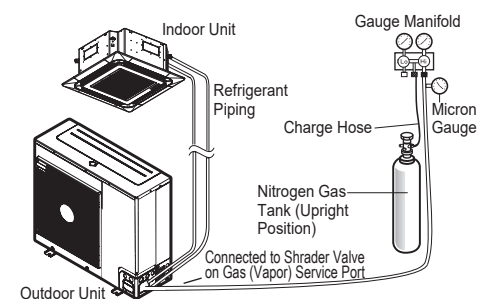

Figure 77: Example of a Triple Leak / Pressure Test Diagram. (Appearances Will Vary Depending on Model.)



FINAL INSTALLATION PROCEDURES

Triple Leak / Pressure and Deep Evacuation Tests

Triple Leak / Pressure Check Procedure, continued.

7. If the pressure does NOT drop for one (1) hour, the system passes the test.
8. If the pressure drops, there is a leak and it must be found. Remove the bubble solution with a clean cloth, repair the leak(s), and perform the leak / pressure check again.
9. After the system has been thoroughly tested and no leaks are found, depressurize by loosening the charging hose connector at the nitrogen cylinder regulator. When system pressure returns to normal, completely disconnect the charging hose from the cylinder, and release the nitrogen charge from all refrigerant piping. Wipe off any remaining bubble solution with a clean cloth.

Deep Evacuation Procedure

After the leak / pressure check is complete, it is required that a deep evacuation procedure is performed to the refrigerant piping and the connected indoor unit. Deep evacuation must be performed through the gas (vapor) suction line Schrader port on the outdoor unit service port.

Note:

The deep evacuation procedure is required for Single Zone systems. A triple evacuation procedure seen on the following pages is a best practices recommendation for Single Zone systems.

Note:

For faster evacuation, the Schrader core can be removed, and an auxiliary service port can be used. Make sure to re-install the original Schrader core before operating the system.

- Deep evacuate through just the gas (vapor) suction Schrader port on the outdoor unit service port.
- The outdoor unit service valves must remain closed and the stem head access caps tight. ⚠ Do not open the outdoor unit service valves and release the factory refrigerant charge until trim charge is complete, and the system is ready to operate.
- Any field-installed ball valves in the refrigerant system (if used) must be open to ensure all piping is free and clear for deep evacuation on all piping and the connected indoor unit.

Note:

- ⚠ Do not apply power to the system before performing the deep evacuation procedure. There is a possibility that the EEV valve will close and isolate sections of the piping system, making the deep evacuation procedure inconclusive.
- ⚠ Never perform evacuation using refrigerant.
- Use only a vacuum pump that can reach 500 microns, vacuum rated hoses or copper tubing, and a leak-free gauge manifold set.
- Use only new vacuum pump oil from a properly sealed (unopened) container, and change oil in pump before EVERY use.
- Subsequent oil changes will be necessary after several hours of continuous operation; have extra oil on hand.
- Use a quality micron gauge in good operating order and install as far away from pump as possible.

Deep Evacuation Procedure Steps

1. If this procedure is performed shortly after the leak / pressure test, the cap and core on the gas (vapor) suction Schrader port must have already been removed, and the manifold must already be connected. If the procedure was not performed shortly after the leak / pressure test, make sure to remove the cap and core on the gas (vapor) suction Schrader port. Verify that the service valves on the outdoor unit are closed, and the stem head access caps are tight.
2. Connect the gauge manifold along with the vacuum pump to the gas (vapor) suction Schrader port (with core removed) using a vacuum hose. Open the gauge manifold and the vacuum pump valves.

Figure 78: Gauge Manifold Hose Connected to the Schrader Valve on the Gas (Vapor) Service Port. (Appearances Will Vary Depending on Model.)

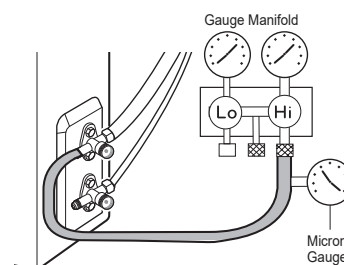

FINAL INSTALLATION PROCEDURES

Deep Evacuation and Triple Evacuation Tests

Deep Evacuation Procedure, continued.

3. Evacuate to static micron level ≤ 500 for at least one (1) hour.
4. Micron level must remain ≤ 500 for two (2) hours. If the vacuum gauge rises and stops, the system may contain moisture; therefore, it will be necessary to repeat the steps of vacuum break and drying.
5. After maintaining the system in vacuum for two (2) hours, check if the vacuum gauge rises or not. If it doesn't rise, then the system is properly evacuated.
6. Close manifold gauges.
7. Shut the valves before turning off and disconnecting the vacuum pump.

Figure 79: Evacuation Procedure Diagram. (Appearances Will Vary Depending on Model.)

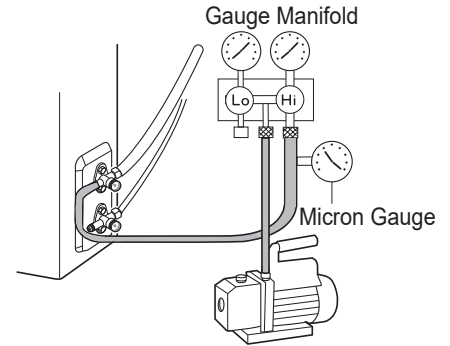

Triple Evacuation Procedure

After the leak / pressure check is complete, it is a best practices recommendation that a triple evacuation procedure is performed to the refrigerant piping and the connected indoor unit. Triple evacuation must be performed through the gas (vapor) suction Schrader port on the outdoor unit service port.

Note:

The deep evacuation procedure is required for Single Zone systems. The triple evacuation procedure is a best practices recommendation for Single Zone systems.

Note:

For faster evacuation, the Schrader core can be removed, and an auxiliary service port can be used. Make sure to re-install the original Schrader core before operating the system.

- Evacuate through just the gas (vapor) suction Schrader port on the outdoor unit service port.
- The outdoor unit service valves must remain closed and the stem head access caps tight. ⚠ Do not open the outdoor unit service valves and release the factory refrigerant charge until trim charge is complete, and the system is ready to operate.
- Any field-installed ball valves in the refrigerant system (if used) must be open to ensure all piping is free and clear for evacuation on all piping and connected indoor unit.

Note:

- ⚠ Never perform evacuation using refrigerant.
- Use only a vacuum pump that can reach 500 microns, vacuum rated hoses or copper tubing, and a leak-free gauge manifold set.
- Use only new vacuum pump oil from a properly sealed (unopened) container, and change oil in pump before EVERY use.
- Subsequent oil changes will be necessary after several hours of continuous operation; have extra oil on hand.
- Use a quality micron gauge in good operating order and install as far away from pump as possible.

FINAL INSTALLATION PROCEDURES

Triple Evacuation Test

Triple Evacuation Procedure Steps

1. If this procedure is performed shortly after the leak / pressure test, the cap and core on the gas (vapor) suction Schrader port must have already been removed, and the manifold must already be connected. If the procedure was not performed shortly after the leak / pressure test, make sure to remove the cap and core on the gas (vapor) suction Schrader port. Verify that the service valves on the outdoor unit are closed, and the stem head access caps are tight.
2. Connect the gauge manifold along with the vacuum pump to the gas (vapor) suction Schrader port (with core removed) using a vacuum hose. Open the gauge manifold and the vacuum pump valves.

Note:

After the vacuum pump is first operated, if hoses, manifold, and vacuum valves are leak free (and oil is not moisture laden), the gauge must read <100 microns within one (1) minute.

⊘ *Do not proceed if the gauge does not read <100 microns within one (1) minute. There is a leak in the hose, gauge manifold, or vacuum valve, and the equipment must be replaced.*

3. Operate the vacuum pump and evacuate the system to the 2,000 micron level. Isolate the pump by closing the manifold gauges and the vacuum pump valve, and then watch the micron level. Micron level will rise a bit, but MUST eventually stop rising for fifteen (15) minutes.
 - If the micron level DOES NOT stop rising, there is a leak, and the leak test must be performed again.
 - If the micron level DOES rise above 2,000 micron, re-open the manifold gauges and the vacuum pump valve and continue evacuation back down to 2,000 micron level.
 - If the micron level holds at 2,000 micron, continue to step 4.
4. Break vacuum with 50 psig nitrogen purge for an appropriate amount of time (this is to “sweep” moisture from piping).
5. Purge nitrogen from the system until the pressure drops down to 1 to 3 psig.
6. Evacuate to 1,000 micron level. Isolate the pump by closing the manifold gauges and the vacuum pump valve, and then watch the micron level. Micron level will rise a bit, but MUST eventually stop rising for fifteen (15) minutes.
 - If the micron level DOES NOT stop rising, there is a leak, and the leak test must be performed again.
 - If the micron level DOES rise above 1,000 micron, re-open the manifold gauges and the vacuum pump valve, and continue evacuation back down to 1,000 micron level.
 - If the micron level holds at 1,000 micron, continue to step 7.
7. Break vacuum with 50 psig nitrogen purge for an appropriate amount of time.
8. Purge nitrogen from the system until the pressure drops down to 1 to 3 psig.
9. Evacuate to static micron level ≤ 500 for at least one (1) hour.
10. Micron level must remain ≤ 500 for two (2) hours. If the vacuum gauge rises and stops, the system may contain moisture; therefore, it will be necessary to repeat the steps of vacuum break and drying.
11. After maintaining the system in vacuum for two (2) hours, check if the vacuum gauge rises or not. If it doesn't rise, then the system is properly evacuated.
12. Close manifold gauges.
13. Shut the valves before turning off and disconnecting the vacuum pump.

FINAL INSTALLATION PROCEDURES

Refrigerant Trim Charge

Refrigerant Trim Charge

The single zone system will need an additional refrigerant charge if the installed piping lengths are greater than the “piping length (no additional refrigerant, ft.) specification” listed in the product tables. See the product sections in the engineering and installation manuals. The system must have the right amount of refrigerant; if the amount of refrigerant level is low, the system will not perform properly. The additional refrigerant charge can be calculated manually using the information in the engineering and / or installation manuals, or by LATS.

1. Keep the outdoor unit service valves closed while adding the trim charge to the system. Charge through the Schrader port. See specification tables in the front of this installation manual for base charge, and see the LATS report for the correct additional refrigerant trim charge amounts for each system.
2. Connect the gauge manifold hose to the gas (vapor) suction Schrader port on the gas service valve.
3. Connect the gauge manifold hose to the refrigerant cylinder. These systems use R410A refrigerant, which must be charged in the liquid state. Verify that the R410A refrigerant cylinder is upside-down.
4. Open both the vapor (gas) and the liquid service valves on the outdoor unit. To open, rotate the valves counter-clockwise by using an Allen wrench.
5. Charge the refrigerant by adjusting the low-pressure valve of the gauge manifold. See the LATS report.
6. After the correct amount of additional refrigerant is charged, close the low-pressure valve of the gauge manifold, and remove the low-pressure hose from the outdoor unit.

⚠ WARNING

-  Never inhale or handle refrigerant directly. Doing so will cause bodily injury.
- Follow all local, state, and federal guidelines when handling refrigerant. If all regulations are not followed, it will cause bodily injury.

Refrigerant Line Length Derates

For air-cooled systems, a capacity correction factor will have to be applied to account for the length of the system’s refrigerant pipe. Rate of change in capacity due to increased piping lengths is shown below.

Table 27: 9,000 and 12,000 Btu/h Capacity Cassette System Cooling and Heating Capacity Coefficient Factors.

Piping Length (ft.)		24.6	32.8	49.2	65.6	98.4	131.2	164.0	196.9	229.7	246.0
Cooling Capacity Coefficient Factor											
Rate of Capacity Change (%)	LC098HV (9,000 Btu/h)	100	99.7	99.2	98.7	-	-	-	-	-	-
	LC128HV (12,000 Btu/h)	100	99.7	99.2	98.7	-	-	-	-	-	-
Heating Capacity Coefficient Factor											
Rate of Capacity Change (%)	LC098HV (9,000 Btu/h)	100	99.7	99.2	98.7	-	-	-	-	-	-
	LC128HV (12,000 Btu/h)	100	99.7	99.2	98.7	-	-	-	-	-	-

Table 28: 18,000 to 42,000 Btu/h Capacity Cassette System Cooling and Heating Capacity Coefficient Factors.

Piping Length (ft.)		24.6	32.8	49.2	65.6	98.4	131.2	164	196.9	229.7	246
Cooling Capacity Coefficient Factor.											
Rate of Capacity Change (%)	LC188HV (18,000 Btu/h)	100	100	99.3	97.9	96.6	93.8	91.1	-	-	-
	LC249HV (24,000 Btu/h)	100	100	99.3	97.9	96.6	93.8	91.1	-	-	-
	LC369HV (36,000 Btu/h)	100	100	99.3	97.9	96.6	93.8	91.1	88.4	85.6	82.9
	LC429HV (42,000 Btu/h)	100	100	99.3	97.9	96.6	93.8	91.1	88.4	85.6	82.9
Heating Capacity Coefficient Factor.											
Rate of Capacity Change (%)	LC188HV (18,000 Btu/h)	100	99.3	97.9	96.6	9.8	91.1	88.4	-	-	-
	LC249HV (24,000 Btu/h)	100	99.3	97.9	96.6	9.8	91.1	88.4	-	-	-
	LC369HV (36,000 Btu/h)	100	99.7	99.2	98.7	97.7	96.6	95.6	94.6	93.5	93.0
	LC429HV (42,000 Btu/h)	100	99.7	99.2	98.7	97.7	96.6	95.6	94.6	93.5	93.0

Note:

- Capacity is based on standard length.
- Equivalent Pipe Length = Actual Pipe Length + Number of Bends x 0.3.
- Additional Refrigerant Charge Calculation : $X (g) = [(Refrigerant Pipe Length) - (No Charge Pipe Length)] \times (Additional Refrigerant)$.
- There is no need to add refrigerant if equivalent pipe is less than the “piping length with no additional refrigerant”.

Figure 80: Gauge Manifold Hose Connected to the Schrader Valve on the Gas (Vapor) Service Port. (Appearances Will Vary Depending on Model.)

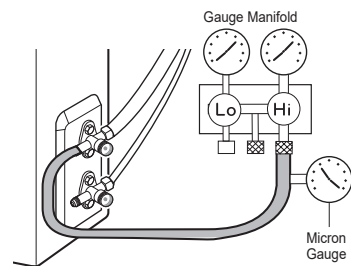
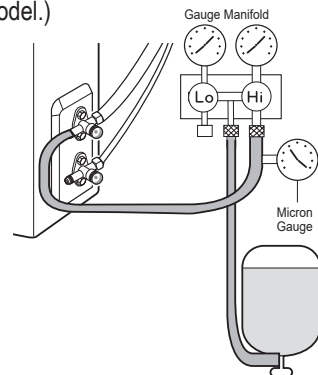

Figure 81: Charging R410A Refrigerant. (Appearances Will Vary Depending on Model.)



FINAL INSTALLATION PROCEDURES

Installing Batteries, Test Run

Finishing the Job

After the Triple Leak and Evacuation (and refrigerant trim charge, if any) procedures have been performed, follow the steps below to open the refrigerant lines.

1. Verify that the auxiliary service port is removed (if used in the Evacuation procedure) and the original Schrader core was re-installed on the gas (vapor) suction service port.
2. The service ports are a back-seated type with a right hand thread. Remove the service valve caps on both the gas (vapor) suction and the liquid service ports.
3. Using an appropriately sized Allen wrench, fully open the valves on both the gas (vapor) suction and the liquid service ports by turning the valve stem counterclockwise.
4. Turn until the valve stem is out, stops, and the valve is completely backseated. ⚠ Do not apply excessive force.
5. Securely replace service port caps on both the gas (vapor) suction and the liquid using an adjustable wrench.

Installing Batteries into the Handheld Remote Controller

For information on using the handheld remote controller, refer to its owner's manual.

1. The remote controller needs two AAA (1.5V) batteries for operation. Remove the battery cover from the back of the remote controller by pushing downward on the tab at the top of the battery cover, and then lift up to remove.
2. Insert the two new batteries.
 - Align batteries by the (+) and (-) sides.
 - The interior battery compartment of the remote controller will have clear markings for the (+) and (-) placement.
3. Verify that the batteries have clicked into the compartment and are firmly engaged with the contacts on either side of them.
4. Reattach the back cover of the remote controller.
5. Proceed with powering on the remote controller and use as needed. Remove the batteries if system won't be used for an extended time.

Figure 82: Installing the Remote Controller Batteries.

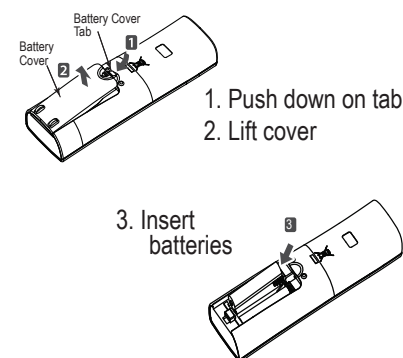

Test Run

After all installation procedures are complete, the system is ready for a test run. Follow the guidelines below.

1. Verify that the power supply is $\pm 10\%$ of the rated voltage.

⚠ WARNING

All power wiring installation must be performed by trained service providers working in accordance with local, state, and NEC regulations related to electrical equipment and wiring, and following the instructions in this manual. Failure to do so will lead to electric shock and bodily injury or death.

⚠ NOTE

All power wiring installation must be performed by trained service providers working in accordance with local, state, and NEC regulations related to electrical equipment and wiring, and following the instructions in this manual. Failure to do so will lead to property damage and equipment malfunction.

2. Check that all drain piping, refrigerant piping, and wiring / cables are properly connected. Check if the drain piping and refrigerant piping are fully and correctly insulated.
3. Check that both the gas (vapor) suction and liquid refrigerant piping service valves are fully open.
4. Install the batteries into the handheld remote controller (see above).

FINAL INSTALLATION PROCEDURES

Test Run, Performance Evaluation

5. Turn on the power. Press and hold the Room Temperature Check and the Down Timer buttons on the remote controller simultaneously for three (3) to five (5) seconds; this switches the system to test operation mode.

6. Test the system in cooling operation first, even if installing in heating season.

⚠ WARNING

If the test operation mode runs in heating mode first, the compressor will be damaged, and system malfunction could lead to electric shock, bodily injury, or death.

⚠ NOTE

If the test operation mode runs in heating mode first, the compressor will be damaged, and system malfunction could lead to property and product damage.

7. To cancel the test operation mode, press any button on the remote controller.

Performance Evaluation

1. Allow the system to run (cooling or heating with maximum air flow) for at least five (5) to fifteen (15) minutes. Test operation mode automatically cancels and returns to the factory default setting after eighteen (18) minutes.
2. While the system operates in test operation mode, measure, record, and save any data (room temperature, outdoor temperature, suction temperature, piping temperature, condensate drainage, electrical specifications, any abnormal vibration or operating noise), note any issues that occur.
3. Measure the operating pressure and compressor pressure. Check if the air circulation is adequate, check for refrigerant leaks.
4. Measure the air temperature from both the inlets and outlets of the indoor unit.
5. Verify the difference between the inlet and outlet temperatures is $> 14.4^{\circ}\text{F}$. If it is, the system is functioning normally in cooling.
6. If issues are found, fix as necessary.
7. If no issues are found, cancel the test operation mode. The air conditioner is now ready to use.

Note:

- If all modes can't be tested all at one time, test later when weather conditions permit.
- If the actual pressure is higher than shown, the system is most likely overcharged, and charge must be removed. If the actual pressure is lower than shown, the system is most likely undercharged, and charge must be added.

Figure 83: Performance Evaluation Air Temperature Measurement Locations.

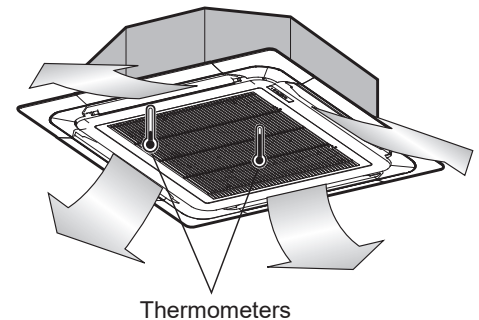

Table 29: Gas Side Pressure at Optimum Condition When System is in Cooling.

Outside Ambient Temperature	Gas (Vapor) Service Valve Pressure
95°F	120~135 psig

FINAL INSTALLATION PROCEDURES

Installing the Panel

Four-Way Panel Installation, General

Note:

- Panel is an accessory that is sold separately.
- Before installing the panel, always remove the paper template first.
- For more details, see the installation instructions that are shipped with the panel.

1. Install the two screws (M5) on the cassette frame (factory supplied). Tighten only about 3/8 inch.
2. Remove the air inlet grille from the panel. (Remove the hook for the air inlet grille cord.)
3. Hook the panel key hole on the installed screws, and slide the panel so that the screws lock into the key hole edge.
4. Tighten completely the two initially installed screws, and install the two additional screws.
5. Connect the louver motor connector and display connector.
6. After tightening these screws, install the air inlet grille (including the air filter).

Figure 84: Four-Way Cassette Panel Installation.

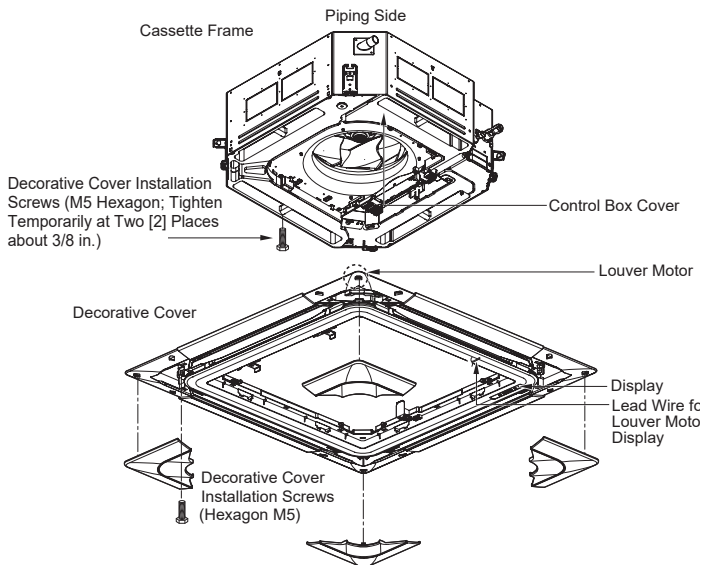

Figure 85: Swing Inlet Grille Downward on the Four-Way Cassette Indoor Unit Frame.

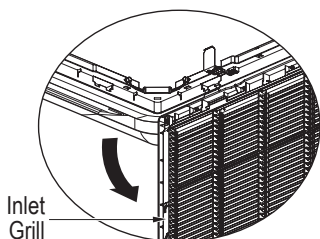
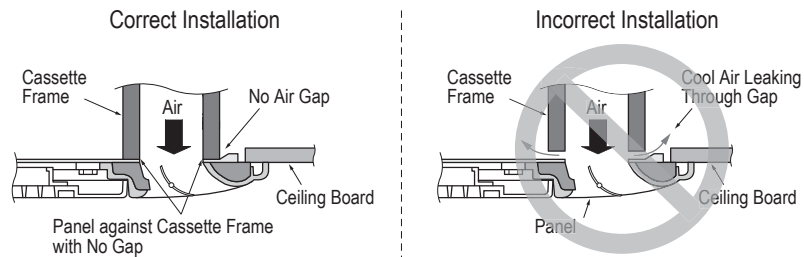

Figure 86: Properly Installing Panel Against the Four-Way Cassette Indoor Unit Frame.



NOTE

Install the panel snugly and without gaps. Any gaps between the ceiling and the cassette frame will release cool air, which will cause sweating. Water drops that fall will damage the surrounding ceiling, floor, and walls.



Due to our policy of continuous product innovation, some specifications may change without notification.
©LG Electronics U.S.A., Inc., Englewood Cliffs, NJ. All rights reserved. "LG" is a registered trademark of LG Corp.

FINAL INSTALLATION PROCEDURES

Installing the Panel

Note:

There are two types of installation methods; refer to the instructions that match the specific panel ordered.

Installing the Panel, Method 1

NOTE

Panel (required; sold separately) must be installed properly; cool air will leak from any gaps found between the indoor unit frame and the panel, condensation will generate, and cause product and property damage.

1. Remove the packaging and paper template, take out air inlet grille from the panel, separating the link from the grille (1A) and then remove the corner covers of the panel (1B).
2. Attach the panel to the indoor frame by inserting the hooks as shown (2).
3. Insert two screws on diagonal corners of each panel, but  do not tighten completely (3) (the screws can be found in the indoor unit shipping box). The screws to attach the panel to the indoor unit frame are factory-provided and can be found in the shipping box. Verify the panel is aligned with the ceiling. Adjust the height by using the hanging bolts as shown. Insert the other two screws, and then tighten all four screws until panel is secure.
4. Attach the corner covers (4).
5. Unscrew the two screws holding the control panel cover (5) and remove (if not removed already). Set aside the control panel cover for re-installation.
6. Connect the one display connector (CN-DISPLAY) and the two vane control connectors (CN-VANE1, CN-VANE2) of the front panel to the indoor unit PCB (6). Reattach the cover of the control box (7).

Figure 87: Installing the Panel, Method 1.



FINAL INSTALLATION PROCEDURES

Installing the Panel

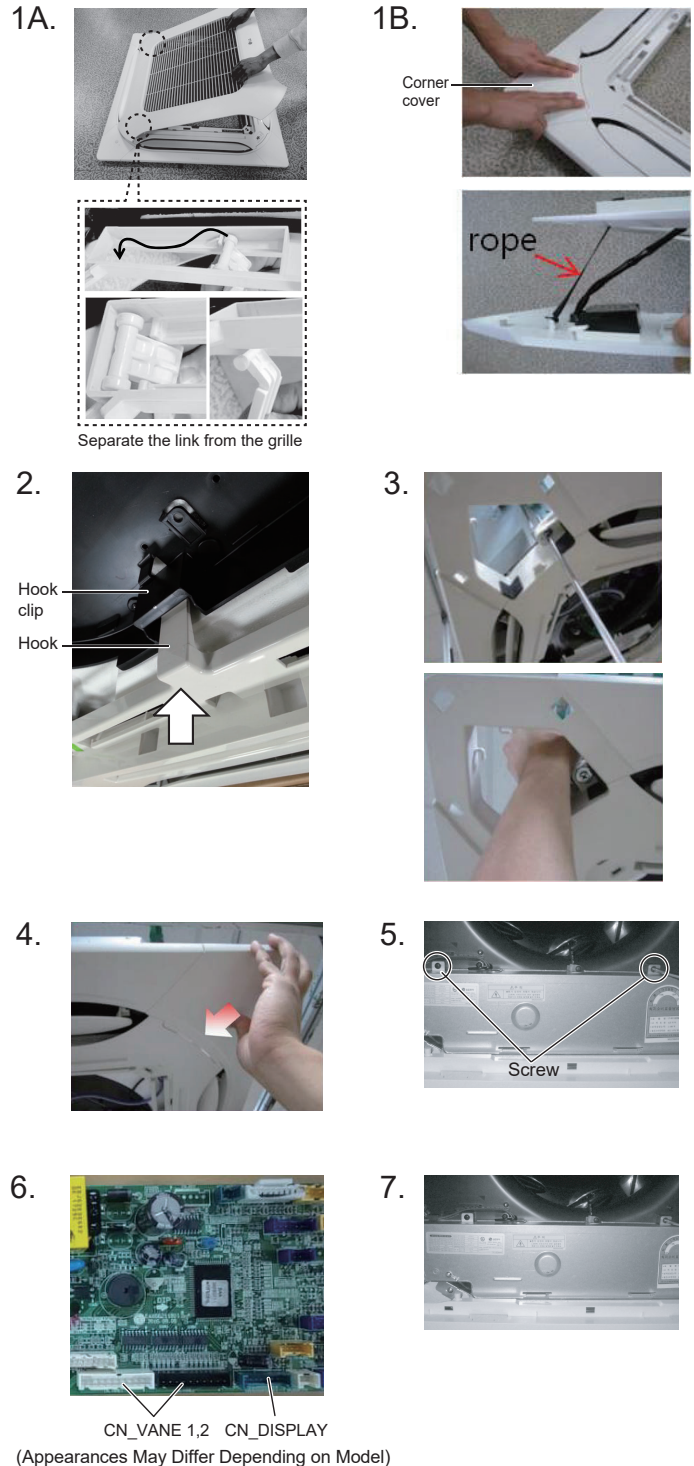
Installing the Panel, Method 1, continued.

7. Reattach the air inlet grille link and filter on the panel as shown (8A). After inserting the edge of the grille into the panel (8B), close the door lock (8C), and then press on the left, right, and center sections to ensure a tight fit (8D).

Figure 89: Installing the Panel, Method 1, continued..

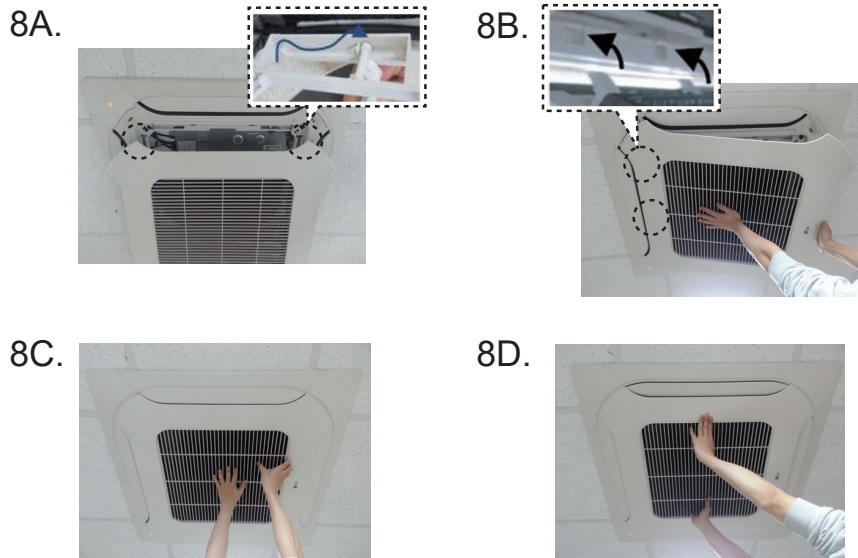
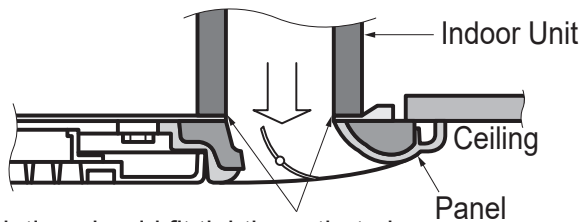

Figure 88: Ensure that no gaps are present between the indoor unit frame and the panel.



Insulation should fit tightly so that air does not leak out where indicated

FINAL INSTALLATION PROCEDURES

Installing the Panel

Installing the Panel, Method 2

⚠ NOTE

Panel (required; sold separately) must be installed properly; cool air will leak from any gaps found between the indoor unit frame and the panel, condensation will generate, and cause product and property damage.

1. Remove the packaging and paper template, take out air inlet grille from the panel (1A), and then remove the corner covers of the panel (1B).
2. Attach the panel to the indoor frame by inserting the hooks as shown (2).
3. Insert two screws on diagonal corners of each panel, but ⚠ do not tighten completely (3). The screws to attach the panel to the indoor unit frame are factory-provided and can be found in the shipping box. Verify the panel is aligned with the ceiling. Adjust the height by using the hanging bolts as shown. Insert the other two screws, and then tighten all four screws until panel is secure.
4. Attach the corner covers (4).
5. Unscrew the two screws holding the control panel cover (5) and remove (if not removed already). Set aside the control panel cover for re-installation.
6. Connect the one display connector (CN-DISPLAY) and the two vane control connectors (CN-VANE1, CN-VANE2) of the front panel to the indoor unit PCB (6).
7. Reattach the control panel cover (7). Attach the filter grille retainer arm (inclusion dependent on model) on the front panel as shown (8). The filter grille retainer arm is supplied in the front panel shipping package.
8. Attach the other side of the filter grille retainer arm on the filter guide of the air inlet grille (9), then install the filter and the air inlet grille on the front panel (10).

Figure 90: Installing the Panel, Method 2.

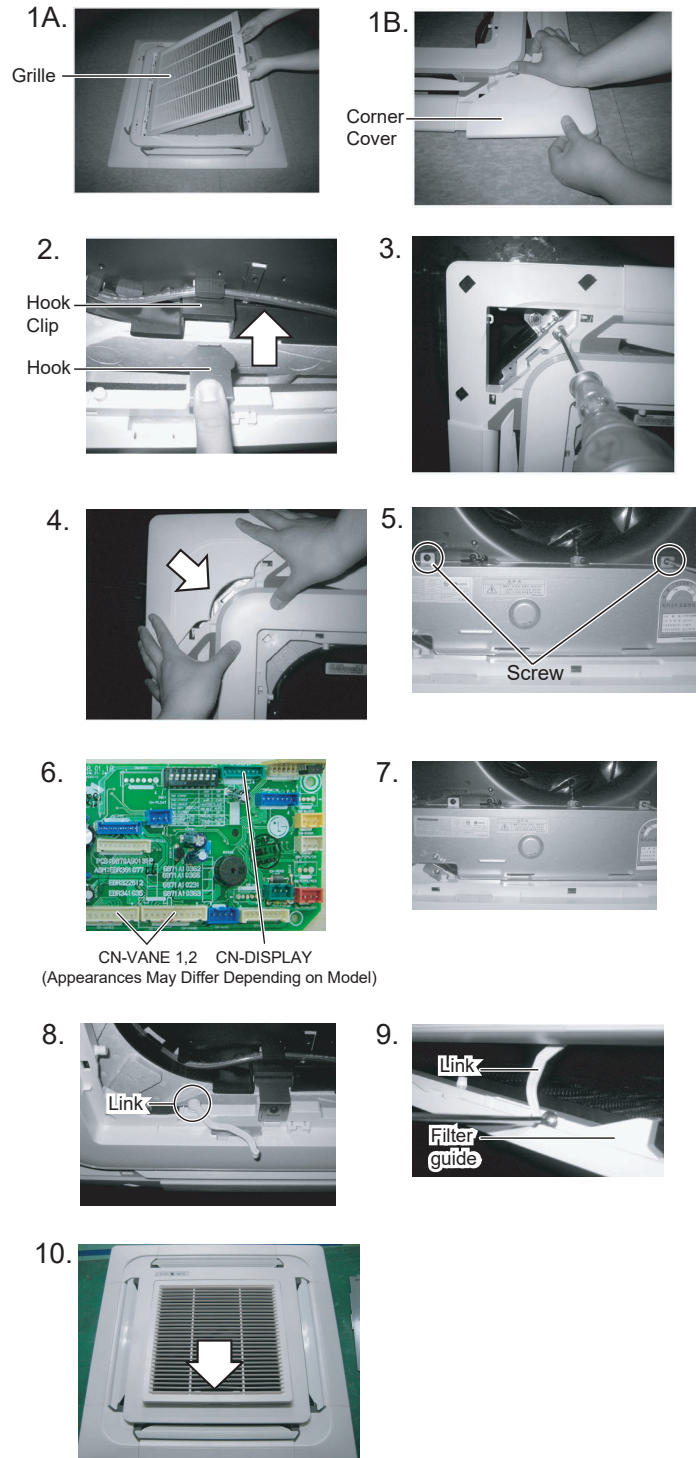
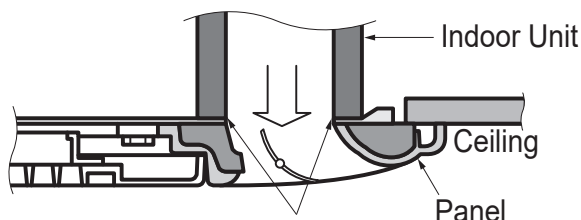

Figure 91: Ensure that no gaps are present between the indoor unit frame and the panel.



Insulation should fit tightly so that air does not leak out where indicated

FINAL INSTALLATION PROCEDURES

Installing the Branch Duct

Branch Duct Installation

Note:

- Branch duct is an optional accessory that is sold separately.
- Instructions on the next few pages are examples of 2x2 cassette branch duct installation. A similar process can be used for 3x3 cassette branch duct installations. See dimensional drawings or measure the 3x3 Cassette indoor units for knockout sizes.

1. Dimensions for 2x2 Cassette single knockouts are 6-1/2 x 3-1/8 in.
2. Cut the side panel and EPS foam of the cassette indoor unit (follow the cabinet perforations).
3. Install insulation between the cassette indoor unit panel and EPS foam. Ensure that the insulation is installed tightly, securely, and with no gaps.

Figure 94: Cutting the Cassette Indoor Unit Side Panel and EPS Foam.

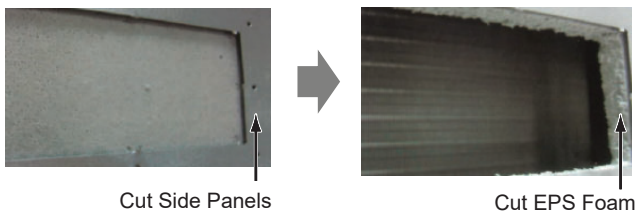
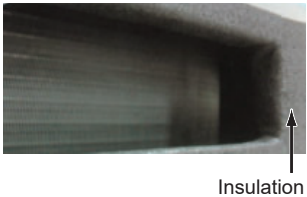

Figure 96: Installing the Insulation.



4. Tightly attach the duct chamber (sub-duct) on the cassette indoor unit cabinet using screws.
5. Cover the duct chamber (sub-duct) and the whole cassette indoor unit cabinet with insulation.

Note:

If insulation does not cover the whole cabinet, condensation will form.

Figure 97: Installing the Duct Chamber (Sub-Duct).

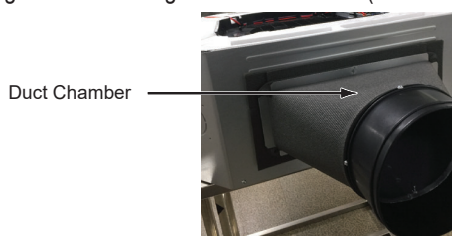

Figure 92: 3x3 Four-Way Cassette Indoor Unit Branch Duct Option Examples.

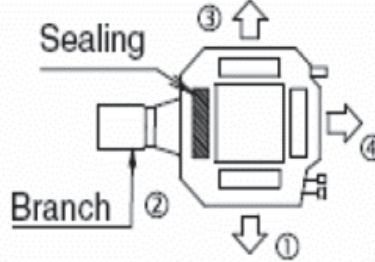
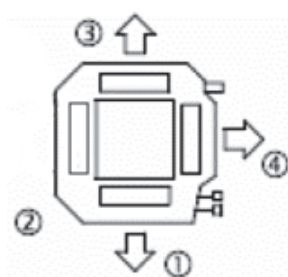

Figure 93: 2x2 Four-Way Cassette Indoor Unit Branch Duct Option Examples.



Note:

- 3x3 Cassette single knockout options: 1, 2, 3, and 4.
- 2x2 Cassette single knockout options: 1, 3, and 4; dimensions: 6-1/2 x 3-1/8 in.

Note:

If there is a gap between the cassette indoor unit panel and the EPS foam, and cold air from the outlet accesses the gap, condensation will form on the cabinet.

Figure 95: Four-Way Cassette 2x2 Indoor Unit Side Panel Dimensions.

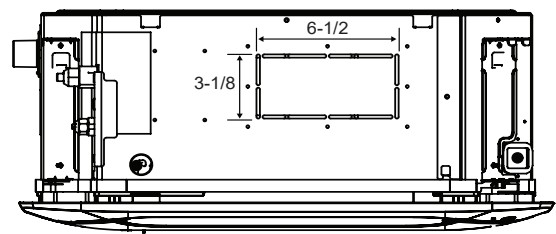

Note:

- Tightly install insulation to the branch duct hole.
- Recommended insulation thickness is more than 3-15/16 inches (10 mm).
- If the insulation thickness is less than 3-15/16 inches (10 mm), condensation will form on / in the cabinet.

Figure 98: Installing Whole Cabinet Insulation.

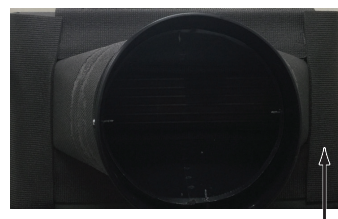

FINAL INSTALLATION PROCEDURES

Installing the Branch Duct

Note:

Instructions on these few pages are examples of 2x2 cassette branch duct installation. A similar process can be used for 3x3 cassette branch duct installations. See dimensional drawings or measure the 3x3 Cassette indoor units for knock out sizes.

6. Install the insulated flexible duct. Use a clamp to secure so that no leaks from the connection occur.
7. Remove the cassette indoor unit front panel, and install insulation to seal the air outlet on the branch duct side.

Note:

If the air outlet is not sealed properly, the branch duct air flow will decrease.

Figure 99: Installing the Insulated Flexible Duct.

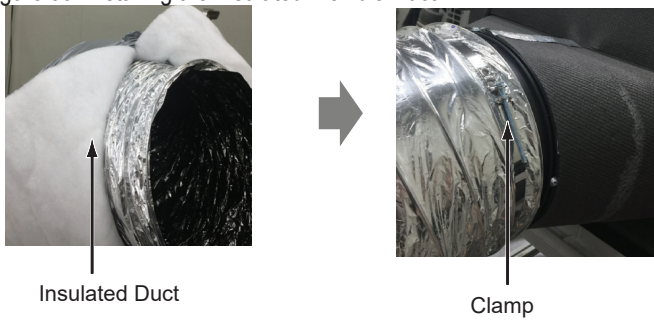

Figure 100: Sealing the Air Outlet on the Branch Duct Side.

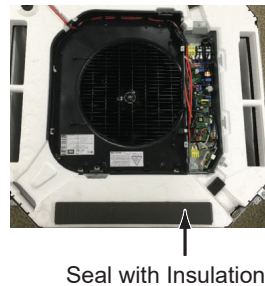
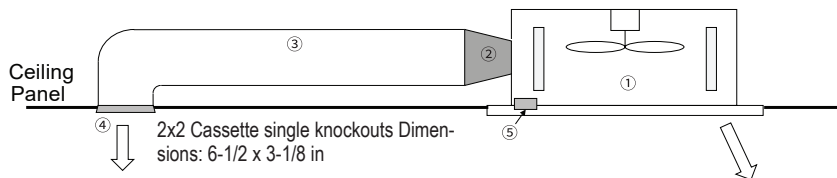

Figure 101: Cassette Indoor Unit Duct System Schematic.



Duct Chamber (Sub-Duct) (2)

Connection between indoor unit and insulated flexible duct.

The duct chamber should be covered by insulation. Thickness of the insulation should be more than 3-15/16 inches (10 mm) on the outside, and 3/16 inches (5 mm) on the inside. If the insulation is not thick enough, condensation will form on the duct chamber (sub-duct).

Duct (3)

Dimensions for 2x2 Cassette single knockouts are 6-1/2 x 3-1/8 in.

The duct should be an insulated flexible duct, or insulation should be installed.

Recommended Air Outlet Insulation Dimension/Thickness

• See diagram at right and information below for recommended air outlet insulation dimensions.

$E = 19-11/16$ inches x $3-1/8$ inches (500 mm x 80 mm)

• Tightly install insulation that covers the entire air outlet.

• Recommended insulation thickness is more than 3/16 inches (5 mm).

Note:

If the insulation thickness is less than 3/16 inches (5 mm), condensation will form on the vane and front panel.

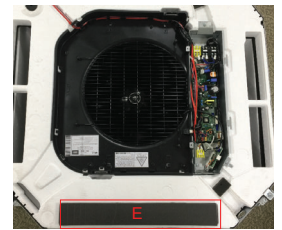

Table 30: Cassette Indoor Unit Duct System Legend.

Label	Component
Factory Supplied (Purchased Separately)	
1	Indoor Unit
Field Supplied	
2	Duct Chamber (Sub-Duct)
3	Duct
4	Vent
5	Air Outlet Insulation

Air Outlet Insulation (5)

Seal the air outlet of the side where the branch duct is installed. The air outlet should be completely sealed to prevent air flow from decreasing.

Note:

- If the insulation on / in the duct chamber (sub-duct) is not thick enough, condensation will form on / in the cabinet.
- If the insulation on the air outlet is not thick enough, condensation will form on the vane and front panel.
- If the insulation on the air outlet does not cover it entirely, condensation will form on the vane and front panel.

FINAL INSTALLATION PROCEDURES

Installing the Branch Duct

Note:

Instructions on these few pages are examples of 2x2 cassette branch duct installation. A similar process can be used for 3x3 cassette branch duct installations. See dimensional drawings or measure the 3x3 Cassette indoor units for knock out sizes.

Duct System Application

Figure 102: Correct Duct System Application; Ducts Should Supply Air to the Same Area in Which the Indoor Unit is Installed.

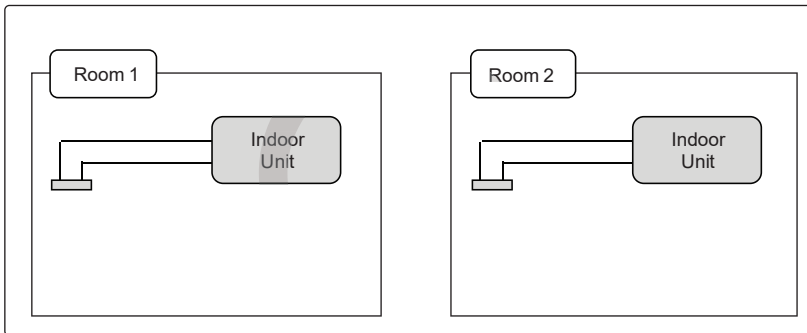
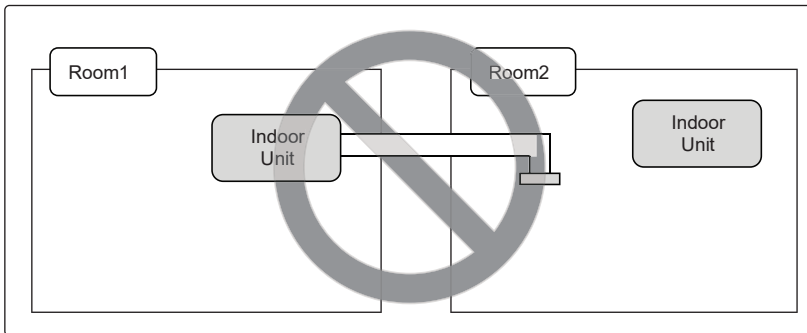

Figure 103: Incorrect Duct System Application.



Note:

⊘ Do not connect the branch duct to another room. There will be a reduction in system performance.

Note:

1. Dimensions for 2x2 Cassette single knockouts are 6-1/2 x 3-1/8 in.
2. All components and connections of the duct system should be completely insulated and sealed with no gaps.
3. If the metal duct is installed through a wood wall, electrically insulate the area between the duct and wall (use a plastic sleeve, etc.).
4. ⊘ Do not install the duct as shown in the images below.

Figure 104: Incorrect Duct Installation Examples.

⊘ Do not sharply bend the duct.



⊘ Do not bend the duct too many times.



⊘ Do not reduce the duct diameter.



FINAL INSTALLATION PROCEDURES

Branch Duct Options

Figure 106: 2x2 Four-Way Cassette Indoor Unit Branch Duct Options.

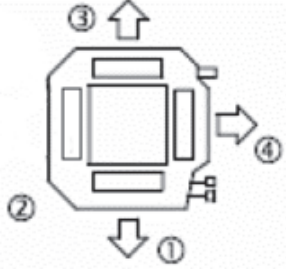

Note:

2x2 Cassette single knockout options: 1, 3, and 4; dimensions: 6-1/2 x 3-1/8 in.

Figure 105: 7,000 to 18,000 Btu/h (TR / TQ) One Side Branch Option P-Q Curves.

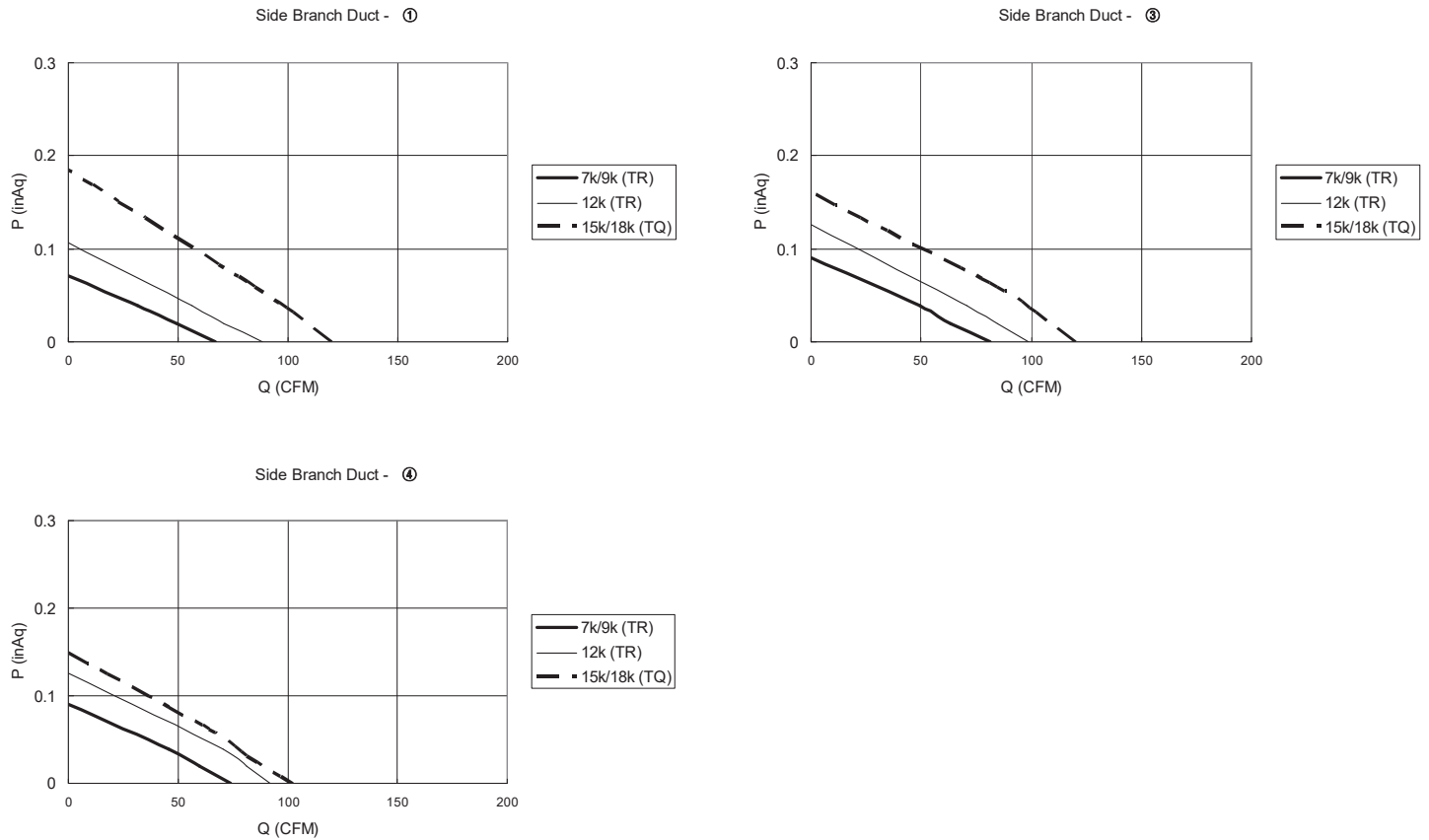

Note:

⊘ Do not connect the branch duct to another room. There will be a reduction in system performance.

FINAL INSTALLATION PROCEDURES

Branch Duct Options

Figure 107: 3x3 Cassette Indoor Unit One Side Branch Options.

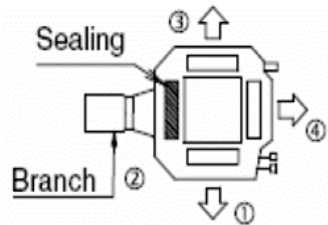

Note:

3x3 Cassette single knockout options: 1, 2, 3, and 4.

Figure 108: 24,000 to 42,000 Btu/h (TP / TN / TM) One Side Branch Option P-Q Curves.

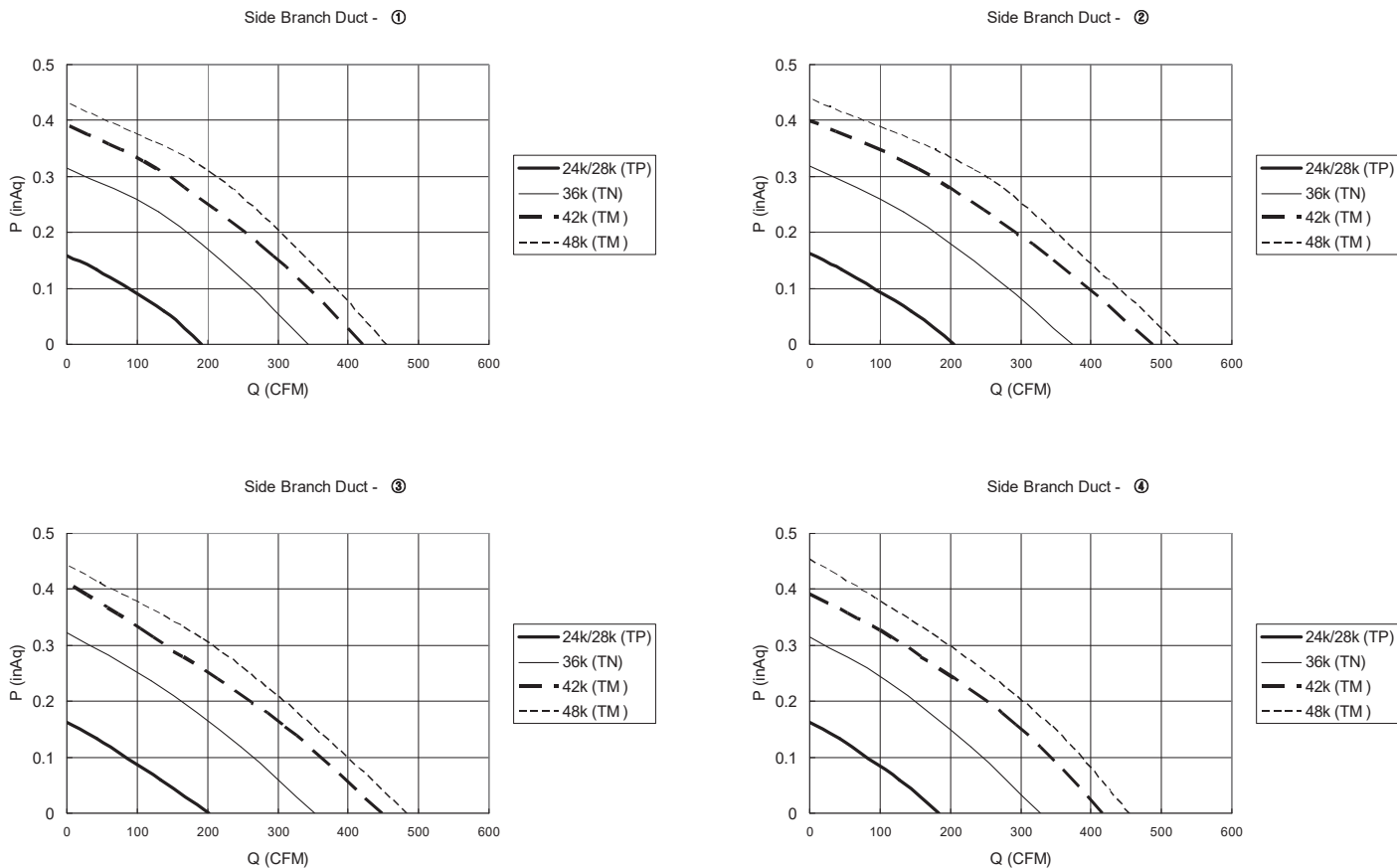

FINAL INSTALLATION PROCEDURES

Branch Duct Options

Figure 109: 3x3 Cassette Indoor Unit Two Sides Side Branch Options.

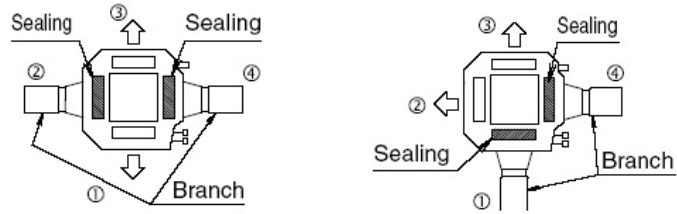
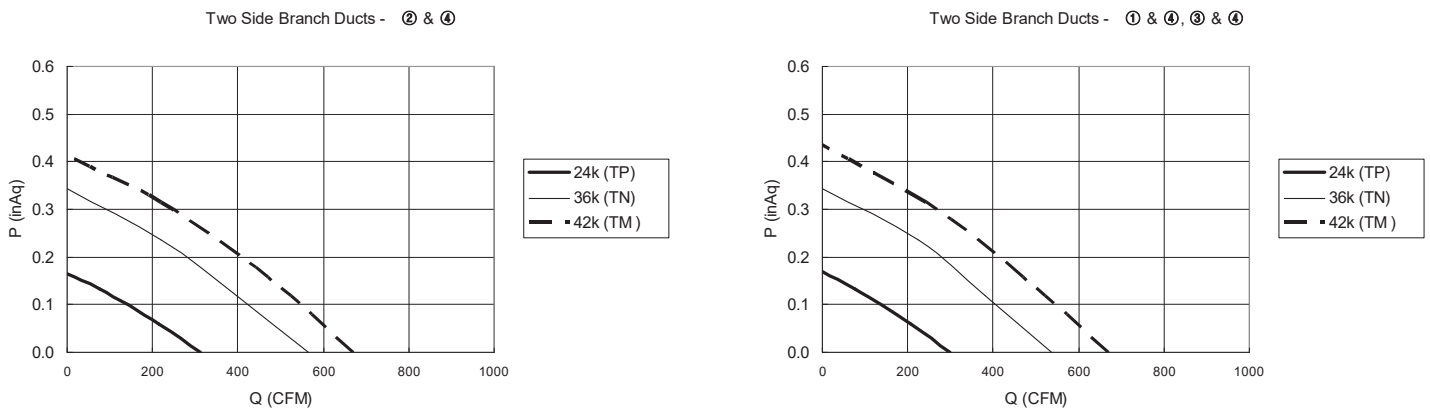

Figure 110: 24,000 to 42,000 Btu/h (TP / TN / TM) One Side Branch Option P-Q Curves.



FINAL INSTALLATION PROCEDURES

Outside Air Ventilation

Figure 111: 9,000 and 12,000 Btu/h TR Frame Outside Air Ventilation with PTVK430 Accessory.

Outside Air Ventilation (with PTVK430)

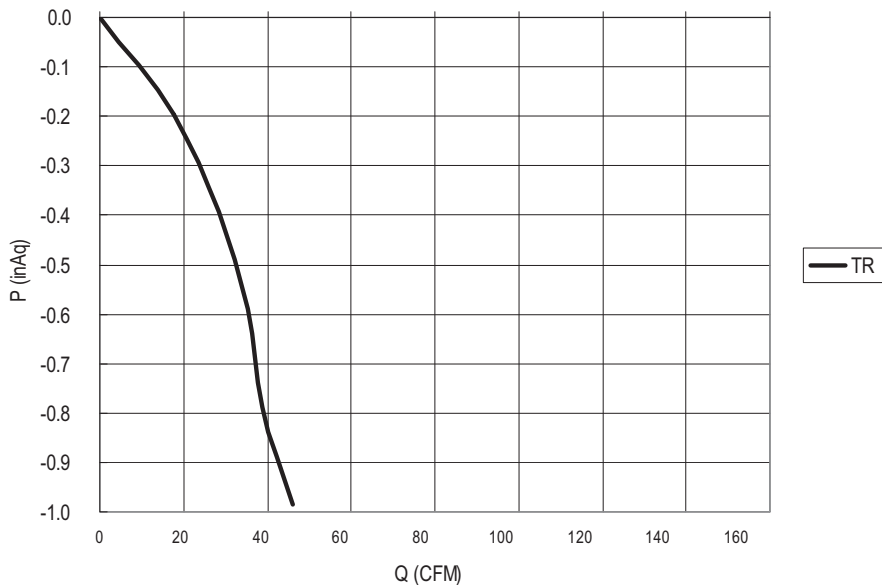
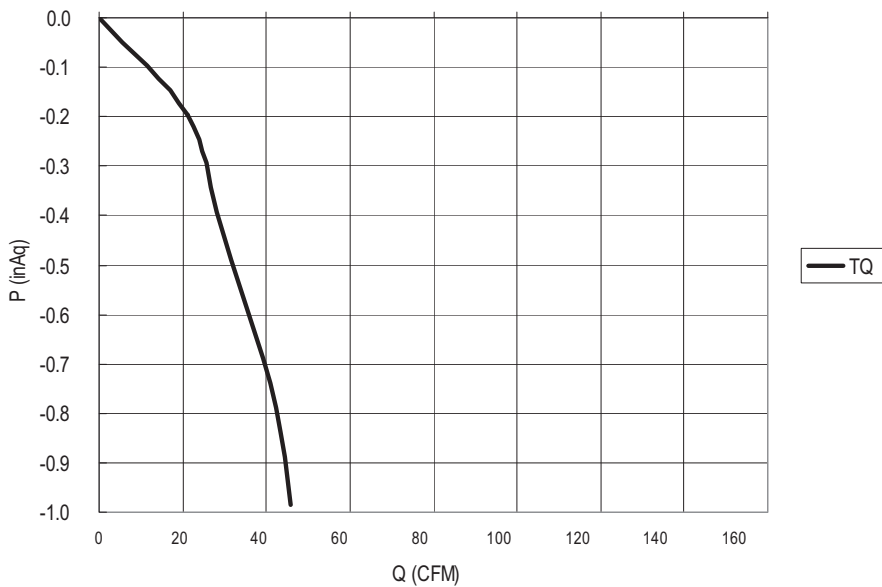

Figure 112: 15,000 and 18,000 Btu/h TQ Frame Outside Air Ventilation with PTVK430 Accessory.

Outside Air Ventilation (with PTVK430)



FINAL INSTALLATION PROCEDURES

Outside Air Ventilation

Figure 113: 24,000 to 42,000 Btu/h TP / TN / TM Frame Outside Air Ventilation with PTVK430 Accessory.

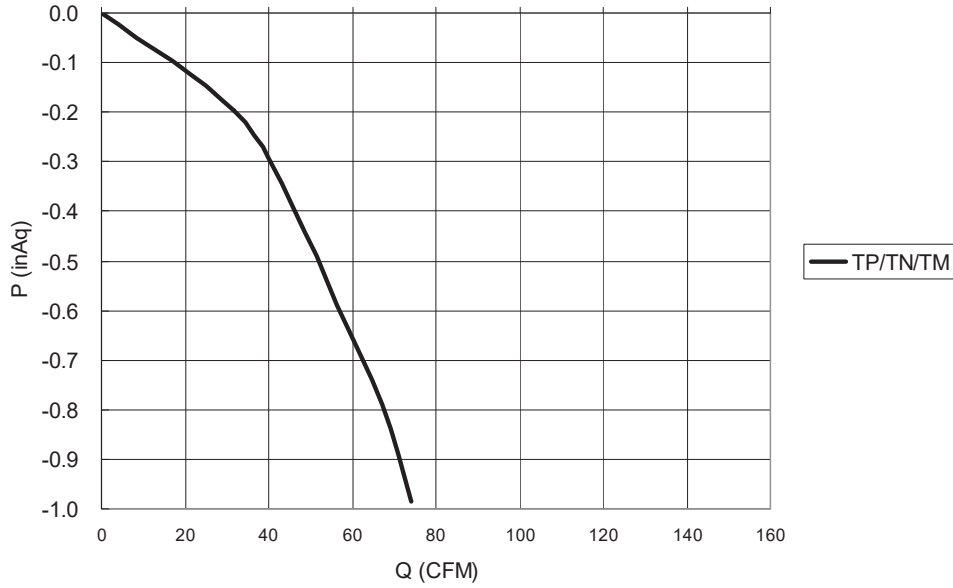
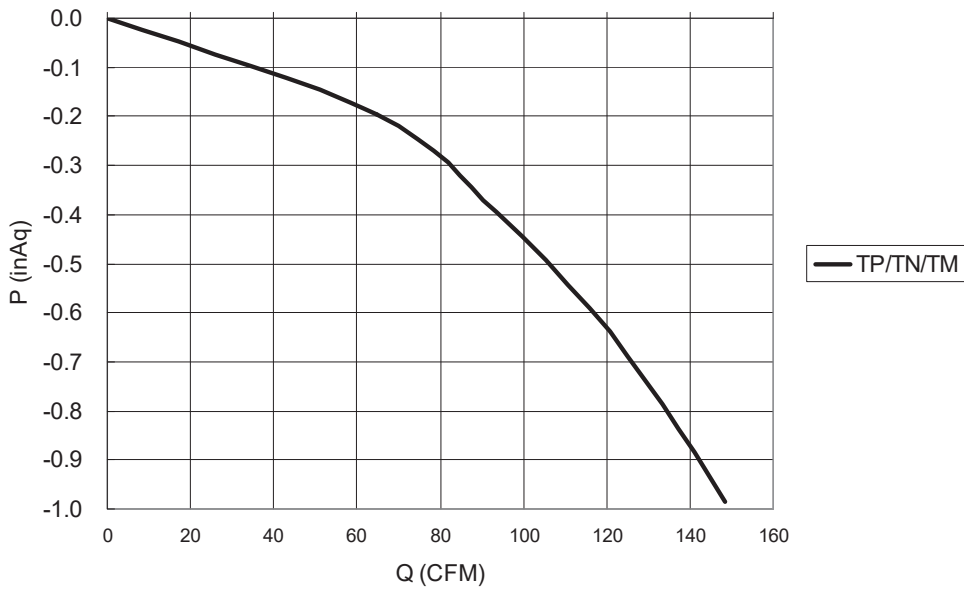

Figure 114: 24,000 to 42,000 Btu/h TP / TN / TM Frame Outside Air Ventilation with PTVK410 + PTVK420 Accessory.



FINAL INSTALLATION PROCEDURES

Installer Setting Mode

Installer Setting Mode

Installer Setting Mode sets system functions. Only trained and licensed HVAC technicians should access / use the Installer Setting Mode. If any installation procedure or system change is performed by someone other than a trained and licensed HVAC technician, LG is not responsible for the results, and it will void the warranty.

⚠ WARNING

If the Installer Setting Mode(s) is (are) not set correctly, a system malfunction could cause fire, electrical shock, physical injury and / or death.

⚠ NOTE

If the Installer Setting Mode(s) is (are) not set correctly, a system malfunction could cause product and / or property damage.

Figure 115: Entering the Installer Setting Mode.

Entering Installer Setting Mode

1. On the handheld controller, press both the “Reset” and “Jet Cool” buttons. A very slender tool is needed to access the “Reset” button.
2. Set the function code and values by using the Up and Down Temperature buttons (see the Installer Setting Codes table). The Up Temperature button changes the code on the ten (10) digit; the Down Temperature button changes the code on the one (1) digit.
3. After setting the function code(s), aim the handheld controller at the indoor unit, and press the On / Off button one (1) time.
4. Reset the handheld controller to access the general operation mode.

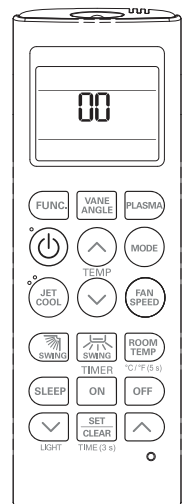

Installer Setting Codes

Table 31: Installer Setting Codes.

No.	Function	Function Code	Setting Value	Handheld Controller LCD
0	Mode Override	0	0: Set to Main	0.0
			1: Set to Sub	0.1
1	Ceiling Height Selection	1	1: Standard	1.1
			2: Low	1.2
			3: High	1.3
			4: Super High	1.4
2	Group Control	2	0: Set to Main	2.0
			1: Set to Sub	2.1
			2: Check Main / Sub	2.2
	Auxiliary Heater	2	3: Set to Auxiliary Heater	2.3
			4: Cancel Auxiliary Heater	2.4
			5: Check Auxiliary Heater Installation	2.5

FINAL INSTALLATION PROCEDURES

Installer Setting Mode

Mode Override

Use Mode Override only with non-autochangeover heat pump models.

Ceiling Height Selection

Use when a wired remote controller is connected to the cassette indoor unit, and operates with the wired remote controller settings.

Group Control

Use for group control. Ⓞ Do not use this function if the system is not set up for group control.

Note:

After setting Group Control, turn the power OFF, wait for one (1) minute, and then turn the power back on.

Auxiliary Heater

This function is only applicable to systems that have the auxiliary heater installed / activated.

Setting the Central Control Address

Set the central control address when the single-zone system is controlled through a central controller and a PI-485 is installed.

1. On the handheld controller, press both the “Reset” and “Mode” buttons. A very slender tool is needed to access the “Reset” button.
2. Use the Up and Down Temperature buttons to set the indoor unit central control address. Setting range: 00 ~ FF.
3. After setting the address, aim the handheld controller at the indoor unit, and press the On / Off button one (1) time.
4. The indoor unit will display the control address setting. Display time and method will differ by indoor unit type.
5. Reset the handheld controller to access the general operation mode.

Checking the Central Control Address

1. On the handheld controller, press both the “Reset” and “Func” buttons. A very slender tool is needed to access the “Reset” button.
2. Aim the handheld controller at the indoor unit, and press the On / Off button one (1) time.
3. The indoor unit will display the control address setting. Display time and method will differ by indoor unit type.
4. Reset the handheld controller to access the general operation mode.

Figure 116: Setting the Central Control Address.

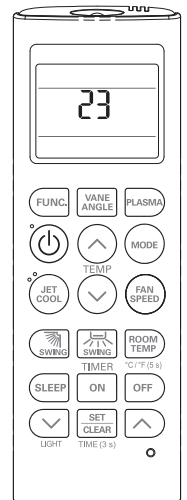

FINAL INSTALLATION PROCEDURES

FC-15 and FC-6 / FC-35

FC-15 / FC-6 (Thermo On / Off Differential)

Allows installer setting (field adjustment) of temperature targets. Use FC-15 / FC-6 in applications to overcome the height difference with indoor units installed high on the wall or in the ceiling.

Both wired (FC-15) and handheld wireless (FC-6) controllers can access the thermo on / off differential. Indoor unit logic must include the function to see the setting codes. If the function is visible, all sub-settings will display, even if the indoor unit logic is limited.

Note:

- Indoor unit logic limits may prevent all sub-settings from being assignable.
- A sub-setting that isn't recognized by the indoor unit will revert to the default setting.
- The controller will display all sub-settings if the function is available for the indoor unit. Contact an LG Representative for details.

Table 32: Wired Controller Settings FC-15 Set Codes and Displays.

Function	Code	Setting		Step	Display
		TH On	TH Off		
Optional Heating Thermo On / Off	FC-15	Default		0	15:00
		7°F	11°F	1	15:01
		4°F	7°F	2	15:02
		-2°F	2°F	3	15:03
		-1°F	1°F	4	15:04

Table 33: Wireless Handheld Controller Settings FC-6 Set Codes and Displays.

Function	Code	Setting		Step	Display
		TH On	TH Off		
Optional Heating Thermo On / Off	FC-6	Default		0	6:0
		7°F	11°F	1	6:01
		4°F	7°F	2	6:02
		-2°F	2°F	3	6:03
		-1°F	1°F	4	6:04

FC-35 (Thermo Off - Indoor Unit Fan Off)

Turns off the indoor unit fan during Thermo Off. Requires an LG wired controller to configure / set the installer code.

Table 34: Wired Controller Settings FC-35 Set Codes and Displays.

Function	Code	Setting	Step	Display
Indoor Unit Fan Off During Thermo Off	FC-35	Indoor Unit Default Airflow (Logic)	0	35:00
		Indoor Unit Fan OFF	1	35:01
		Setting Airflow	2	35:02

FINAL INSTALLATION PROCEDURES

Setting LUU180-420HV Optional Modes

Setting LUU180-420HV Optional Modes

LUU*** (18 to 42K only) outdoor units feature optional modes that the service provider sets during installation.

⚠ DANGER

Before setting the DIP switches on the PCB for the optional modes, turn the power OFF at the nearest disconnect. Electrical shock can cause physical injury or death.

⚠ WARNING

Only a trained and licensed service should set the DIP switches for the optional modes. The information contained in this manual is intended for use by an industry-qualified, experienced, certified electrician familiar with the U.S. National Electric Code (NEC) who is equipped with the proper tools and test instruments. Failure to carefully read and follow all instructions in this manual can result in personal injury or death.

⚠ NOTE

- The information contained in this manual is intended for use by an industry-qualified, experienced, certified electrician familiar with the U.S. National Electric Code (NEC) who is equipped with the proper tools and test instruments. Failure to carefully read and follow all instructions in this manual can result in equipment malfunction and property damage.
- Optional modes must be properly set with the applicable DIP switches Off or On for each mode. The system will not function properly if the DIP switches are not set properly.
- If the DIP switches are set when the power is ON, the change is not applied. Optional mode changes are only applied when the power is reset.

Location of the Optional Mode DIP Switch Bank on the LUU180HV to LUU420HV Outdoor Units

Figure 117: LUU180HV and LUU240HV Outdoor Unit DIP Switch Bank.

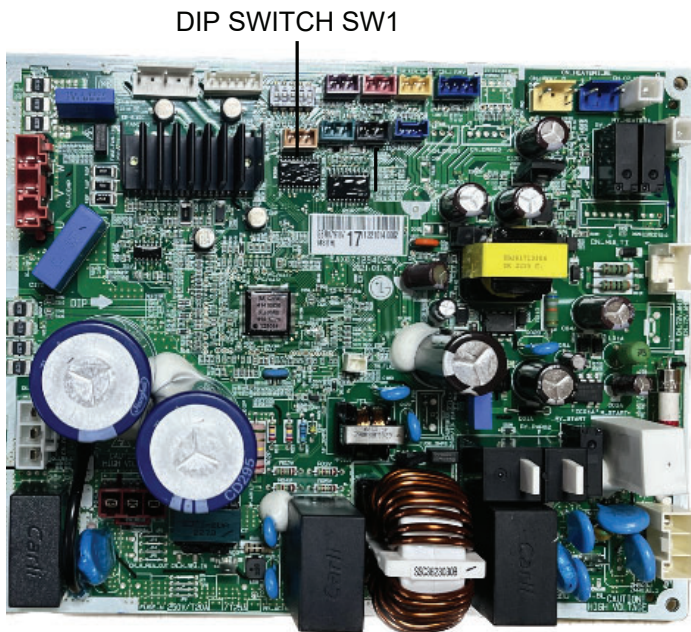
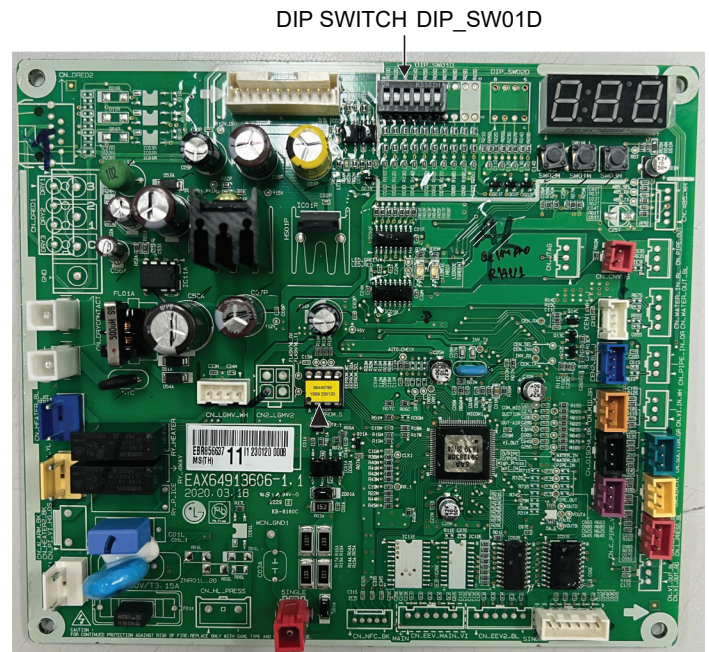

Figure 118: LUU360HV and LUU420HV Outdoor Unit DIP Switch Bank.



Note:







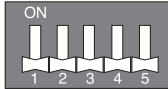
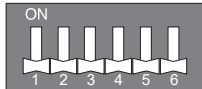
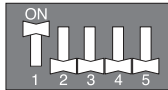
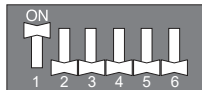
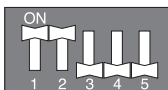
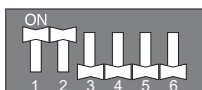

LUU090HV and LUU120HV outdoor units do NOT include DIP switches on the PCBs, therefore, the optional modes listed on the next page are not available for these products.

FINAL INSTALLATION PROCEDURES

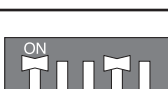
Setting LUU180-420HV Optional Modes

LUU180-420HV Optional Modes

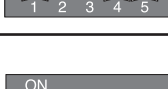
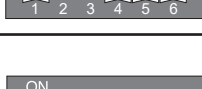
Table 35: LUU180HV, LUU240HV, LUU360HV, and LUU420HV Optional Mode DIP Switch Settings.

DIP Switches		Function
LUU180HV, LUU240HV	LUU360HV, LUU420HV	
1 2 3 4 5	1 2 3 4 5 6	
		Normal Operation (No Function)
		Pump Down
		Mode Lock (Cooling)
		Mode Lock (Heating)
		Night Low Sound Level 1 (Maximum Fan 600 rpm, Compressor 60Hz)
		Night Low Sound Level 2 (Maximum Fan 500 rpm, Compressor 50Hz)
		Night Low Sound + Mode Lock (Cooling) Level 1 (Maximum Fan 600 rpm, Compressor 60Hz)
		Night Low Sound + Mode Lock (Cooling) Level 2 (Maximum Fan 500 rpm, Compressor 50Hz)

FINAL INSTALLATION PROCEDURES

Setting LUU180-420HV Optional Modes

LUU180HV to LUU420HV Optional Modes, continued.

Pump Down

Use Pump Down mode when adding refrigerant.

1. Shut the power OFF to the system.
2. Remove the control box cover.
3. Set DIP Switch No. 1 to ON according to the system installed as shown.
4. Turn the power ON.
5. The red and green LEDs on the outdoor unit PCB will function as detailed below, indicating the indoor unit is in Pump Down mode.
6. After Pump Down mode is complete, the red LED will turn OFF. If Pump Down is not performing normally, the red LED will blink.

Figure 119: Pump Down DIP Switch Settings.

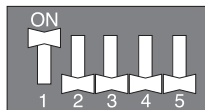

LUU180HV, LUU240HV

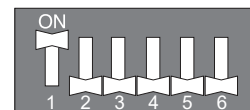

LUU360HV, LUU420HV

Pump Down Flowchart

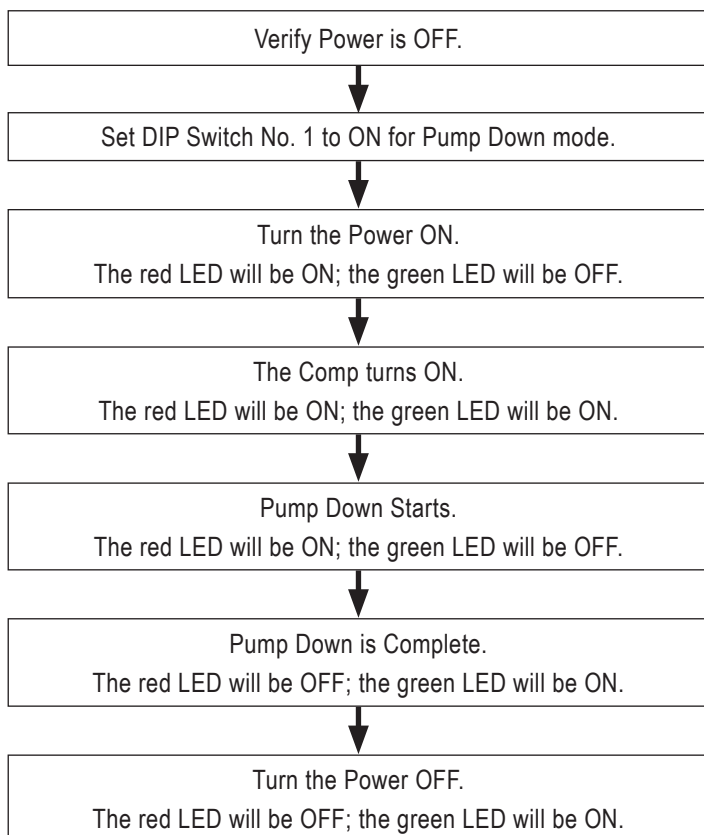

Liquid Valve Closed.

Vapor Valve Closed.

Note:

Close the liquid valve only after the green LED turns OFF (about seven [7] minutes after the system starts), and then close the vapor valve after the green LED turns ON.

Note:

- When the green LED is ON, the compressor will be OFF because of low pressure in the system.
- After Pump Down is finished, ensure the power is OFF, and set DIP Switch No. 1 to OFF for Normal Operation (all DIP switches must be set to OFF for Normal Operation). Turn the power back ON to resume system operation.
- An improper Pump Down procedure will cause the system (along with the red and green LEDs) to shut off within twenty (20) minutes from the initial start.

FINAL INSTALLATION PROCEDURES

Setting LUU180-420HV Optional Modes

Mode Lock (Cooling Only and Heating Only)

1. Shut the power OFF to the system.
2. Remove the control box cover.
3. For Cooling Only Mode Lock, set the DIP Switch Nos. 1 and 2 to ON as shown.
4. For Heating Only Mode Lock, set the DIP Switch Nos. 3 and 4 to ON as shown.
5. Turn the power ON.

Figure 120: Cooling Only Mode Lock DIP Switch Settings.

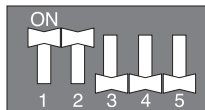

LUU180HV, LUU240HV

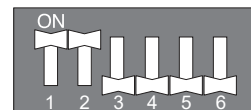

LUU360HV, LUU420HV

Figure 121: Heating Only Mode Lock DIP Switch Settings.

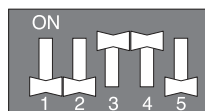

LUU180HV, LUU240HV

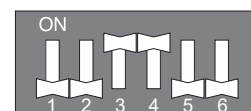

LUU360HV, LUU420HV

Night Low Sound

Night Low Sound mode reduces the operation sound of the outdoor unit by changing the compressor frequency and fan speed. Night Low Sound mode operates the entire night.

Choose from Level 1 or Level 2. See the table below.

Table 36: Night Low Sound Levels Specifications.

Outdoor Unit	Standard Operation dBA	Level 1 dBA (Compressor Hz, Max. Fan Speed RPM)	Level 2 dBA (Compressor Hz, Max. Fan Speed RPM)
LUU180HV	48	47 (60, 600)	42 (50, 500)
LUU240HV	48	47 (60, 600)	42 (50, 500)
LUU360HV	52	50 (73, 600)	44 (56, 400)
LUU420HV	52	50 (73, 600)	44 (56, 400)

1. Shut the power OFF to the system.
2. Remove the control box cover.
3. For Level 1, set DIP Switch Nos. 1 and 4 to ON as shown.
OR
For Level 2, set DIP Switch Nos. 2 and 3 to ON as shown.
4. Turn the power ON.

Note:

- If compressor frequency and fan speed are reduced, cooling capacity may also be reduced.
- Night Low Sound mode can only be used with Cooling mode.
- If Night Low Sound mode needs to be stopped, change the DIP switches.
- If indoor unit operation is set by the fan speed "Power", Night Low Sound mode will stop until the fan speed "Power" is changed.

Figure 122: Night Low Sound DIP Switch Settings Level 1.

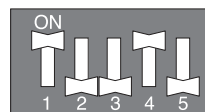

LUU180HV, LUU240HV

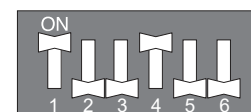

LUU360HV, LUU420HV

Figure 123: Night Low Sound DIP Switch Settings Level 2.

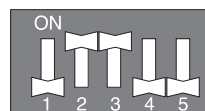

LUU180HV, LUU240HV



LUU360HV, LUU420HV

FINAL INSTALLATION PROCEDURES

Setting LUU180-420HV Optional Modes

Night Low Sound + Mode Lock (Cooling)

This function combines the Night Low Sound function with the Mode Lock function.

Choose from Level 1 or Level 2. See the table below.

Table 37: Night Low Sound Levels Specifications.

Outdoor Unit	Standard Operation dBA	Level 1 dBA (Compressor Hz, Max. Fan Speed RPM)	Level 2 dBA (Compressor Hz, Max. Fan Speed RPM)
LUU180HV	48	47 (60, 600)	42 (50, 500)
LUU240HV	48	47 (60, 600)	42 (50, 500)
LUU360HV	52	50 (73, 600)	44 (56, 400)
LUU420HV	52	50 (73, 600)	44 (56, 400)

1. Shut the power OFF to the system.
2. Remove the control box cover.
3. For Level 1, set DIP Switch Nos. 2 and 4 to ON as shown.
OR
For Level 2, set DIP Switch Nos. 1 and 3 to ON as shown.
4. Turn the power ON.

Note:

- If compressor frequency and fan speed are reduced, cooling capacity may also be reduced.
- Night Low Sound mode can only be used with Cooling mode.
- If Night Low Sound mode needs to be stopped, change the DIP switches.
- If indoor unit operation is set by the fan speed "Power", Night Low Sound mode will stop until the fan speed "Power" is changed.

Figure 124: Night Low Sound with Mode Lock DIP Switch Settings Level 1.

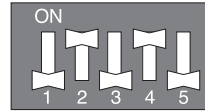

LUU180HV, LUU240HV

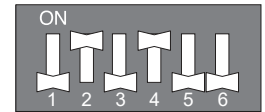

LUU360HV, LUU420HV

Figure 125: Night Low Sound with Mode Lock DIP Switch Settings Level 2.

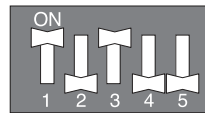

LUU180HV, LUU240HV

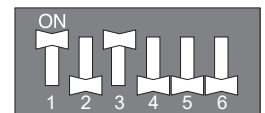

LUU360HV, LUU420HV

FINAL INSTALLATION PROCEDURES

LG Monitoring View (LGMV) Diagnostic Software

LG Monitoring View (LGMV) Diagnostic Software

LGMV software (PRCTSL1 and PRCTFE1) allows the service technician or commissioning agent to connect a computer USB port to the Single Zone unit's main printed circuit board (PCB) using an accessory cable without the need for a separate interface device. The monitoring screen for LGMV allows the user to view the following real time data on one screen:

- Actual inverter compressor speed
- Target inverter compressor speed
- Actual outdoor fan speed
- Target outdoor unit fan speed
- Actual superheat
- Target superheat
- Actual subcooler circuit superheat
- Target subcooler circuit superheat
- Main EEV position
- Subcooling EEV position
- Inverter compressor current transducer value
- Outdoor air temperature
- Actual high pressure/saturation temperature
- Actual low pressure/saturation temperature
- Suction temperature
- Inverter compressor discharge temperature
- Front outdoor coil pipe temperature
- Back outdoor coil pipe temperature
- Liquid line pipe temperature
- Subcooler inlet temperature
- Subcooler outlet temperature
- Average indoor unit (IDU) pipe temperature
- Inverter compressor operation indicator light
- Liquid injection valves' operation indicator lights
- Hot gas bypass valve operation indicator light
- Four-way reversing valve operation indicator light
- Pressure graph showing actual low pressure and high pressure levels
- Error code display
- Operating mode indicator
- Target high pressure
- Target low pressure
- PCB (printed circuit board) version
- Software version
- Installer name
- Model number of IDUs
- Site name
- Total number of connected IDUs

Figure 126: MV Real-time Data Screen.

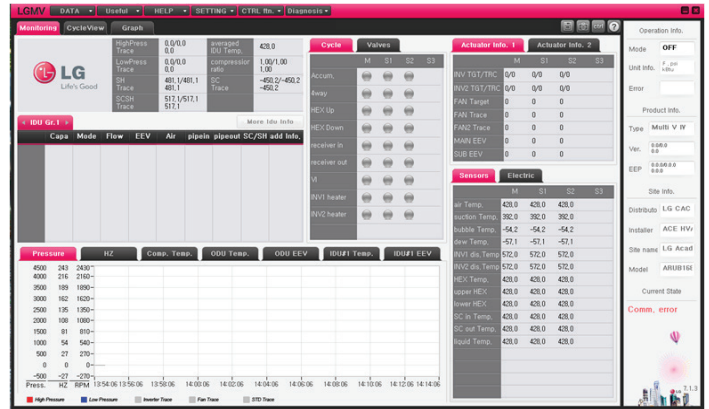

- Communication indicators
- IDU capacity
- IDU operating mode
- IDU fan speed
- IDU EEV position
- IDU room temperature
- IDU inlet pipe temperature
- IDU outlet pipe temperature
- IDU error code

Additional screens can be accessed by tabs on the main screen.

Additional screens include the following:

1. Cycleview: Graphic of internal components including:
 - Compressors showing actual speeds
 - EEVs
 - IDUs
 - Temperature and pressure sensors
 - Four-way reversing valve
2. Graph: Full screen graph of actual high and low pressures and high and low pressure limits. A sliding bar enables user to go back in time and view data.
3. Control FTN: Enables user to turn on IDUs in 1.8°F increments.
4. Useful Tab
 - Unit Conversion: Converts metric values to imperial values.

Figure 127: MV Cycleview.

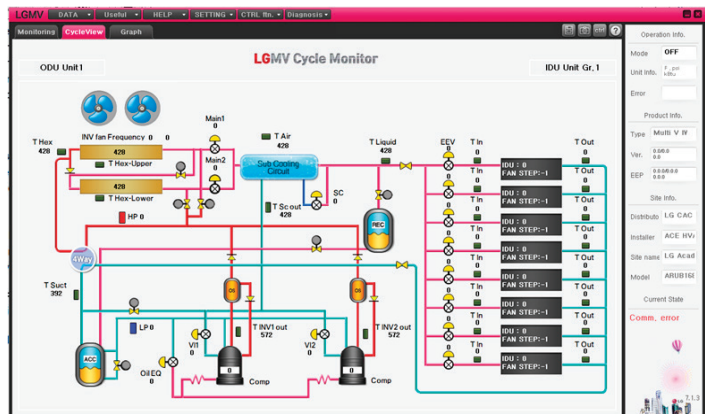

Note:

Images on these pages are examples of LGMV screenshots. Actual images may differ depending on the version of the software and the unit installed.

FINAL INSTALLATION PROCEDURES

LG Monitoring View (LGMV) Diagnostic Software

LG Monitoring View (LGMV) Diagnostic Software and Cable - Continued.

1. Data

- Data Saving Start: Recording of real time data to a separate file created to be stored on the user's computer.
- Data Loading Start: Recorded data from a saved ".CSV" file can be loaded to create an LGMV session.

2. Monitoring

- Electrical: The lower half of main screen is changed to show Inverter Compressor Amps, Volts, Power Hz, Inverter control board fan Hz.

Error Codes

LGMV software helps the service technician or commissioning agent to troubleshoot system operation issues by displaying malfunction codes. These error codes can be seen on the main screen of the LGMV software program. For an overview of Single Zone unit error codes, see Error Codes section. For detailed information on how to troubleshoot individual error codes, see the Single Zone Wall Mount Service Manual.

Figure 128: Error Code Screen.

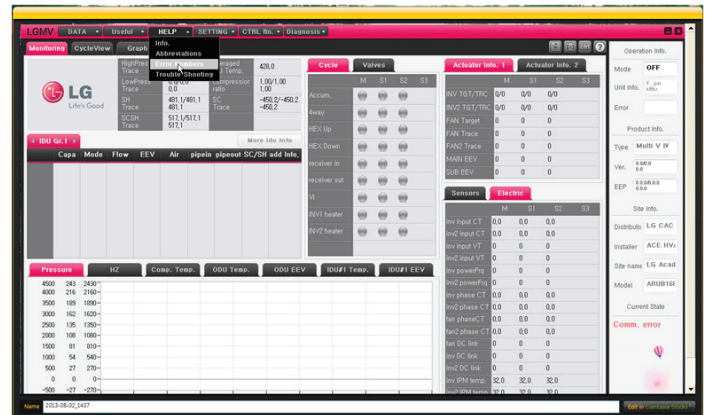

The software is available in a high version with all of the features listed above. The low version has all features as the high version without Target High Pressure and Target Low Pressure values shown on main screen.

In lieu of connecting to the Water Source Unit (WSU), user has the option to connect to IDU with the use of a USB to RS-485 connector kit. When connected through IDU, user will not be able to record data.

This software can be used to both commission new systems and troubleshoot existing systems. LGMV data can be recorded to a ".CSV" file and emailed to an LG representative to assist with diagnostic evaluations.

Note:

- Contact an LG representative for minimum LGMV PC requirements.
- Images on these pages are examples of LGMV screenshots. Actual images may differ depending on the version of the software and the units installed.

FINAL INSTALLATION PROCEDURES

LG ThinQ

LG ThinQ

LG ThinQ is a built-in Wi-Fi module, along with a free smart phone app that provides monitoring and remote control capabilities for certain LG single zone systems. The app has the following features and benefits:

- Sign in to the app using LG credentials, or using Google® or Facebook® login credentials. Users only have to log in to the app once; the app remembers login details for subsequent logins.
- View current temperature settings of the air conditioning unit and change temperature, fan speed, and air flow direction from anywhere in the house or at a remote location (through the use of wireless connection). Multiple users can control the household air conditioning unit remotely.
- Monitor filter usage of the unit.
- Set up weekly schedules to start and stop air conditioner activity.
- Set up the unit to run in different Modes, depending on the user's schedule. Set up specific temperatures for when the user is home, away on vacation, or sleeping.
- Troubleshoot problems, and view tips on general maintenance of the system using the Smart Diagnosis function.

**Google is a registered trademark of Google Inc.; Facebook is a registered trademark of Facebook.*

Contact your LG Sales Representative or visit www.lghvac.com for system requirements, how to download the app, a user's manual, or other information.

Figure 129: Example of an LG ThinQ Screen (appearances may differ depending on version of software).

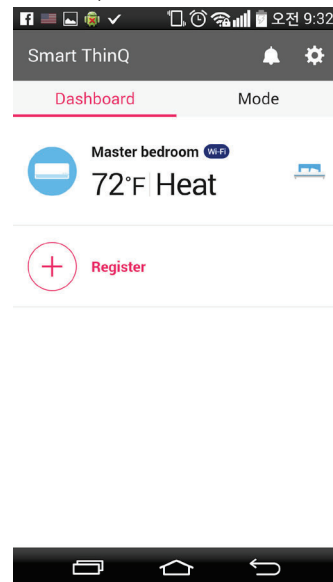

FINAL INSTALLATION PROCEDURES

Error Codes

Troubleshooting Using Error Codes

Refer to the tables below and on the next pages for information on the error codes that are generated from the indoor and outdoor units. These codes are the most common that will manifest through these units. The system installed might generate additional codes not listed here. Contact an LG trained service provider if these types of errors are seen, and a simple power down and boot up has not corrected the issue. The end user should not attempt to fix the system.

Error Codes

- Error codes indicate different types of unit failures, assist in self-diagnosis and to track the frequency of occurrence.
- Error codes are shown on the LEDs of indoor units, wired remote controller, the outdoor unit control board, and LG Monitoring View (LGMV) Diagnostic Software, depending on the system installed.
- If two or more errors occur simultaneously, the error code with the larger issue is displayed first.
- To resume system operation after an error code is resolved, cycle the power off, then back on.
- After error is resolved, the error code does not display.

Decoding the Error Display

The first and second number on the LED indicates error number. Example: 21 = LED1 2x blink, LED2 1x blink.

Error Code Nomenclature Definitions

- MICOM: Non-volatile memory chip where unit setup information is stored.
- EEPROM: Non-volatile memory chip where device identification, size, and factory defined default component operating parameters are stored.

Troubleshooting Using Error Codes, Ceiling Cassette Indoor Units

Figure 130: Ceiling Cassette Indoor Unit Display.

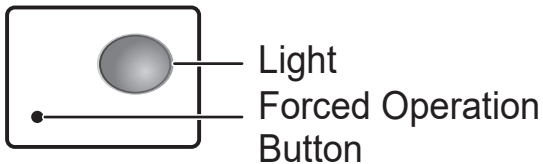

Table 38: Ceiling Cassette Indoor Unit Light Indications.

Description	Color of Display Light
Cooling or Heating Mode	Green
Clean Filter (When System is Operating in Cooling or Heating Mode)	Yellow-Green
Clean Filter (When System is NOT Operating)	Orange
Hot Start or Defrost Mode Before System Starts Heating Mode	Green
Turned On Because of Scheduling (With a Programmable Controller)	Yellow-Green

Table 39: Ceiling Cassette Indoor Unit Error Codes.

Error Code	Description	Details	Indoor Unit Operation Status
01	Indoor Unit Room Air Temperature Room Sensor Error	Indoor unit air temperature sensor is disconnected, shorted, or opened.	Off
02	Indoor Unit Inlet Pipe Sensor Error	Indoor unit inlet pipe temperature sensor is disconnected, shorted, or opened.	Off
03	Remote Controller Error	Indoor unit PCB is not receiving a signal from the wired remote controller (if installed).	Off
04	Drain Pump Error	Drain pump malfunction.	Off
05	Communication Error Between Indoor Unit and Outdoor Unit	Indoor unit PCB is not receiving signal from outdoor unit.	Off
06	Indoor Unit Outlet Pipe Sensor Error	Indoor unit outlet pipe temperature sensor is disconnected, shorted, or opened.	Off
09	Indoor Unit EEPROM Error	Indoor unit EEPROM serial number marked on is 0 or FFFFFF.	Off
10	Indoor Unit BLDC Motor Fan Lock	Indoor unit fan motor connection is disconnected. Indoor unit fan motor lock has failed.	Off

Figure 131: Wired Remote Controller Display.

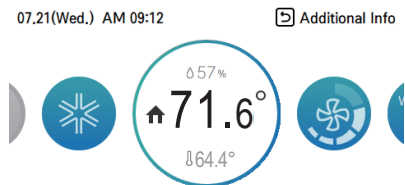

FINAL INSTALLATION PROCEDURES

Error Codes

Troubleshooting Using Error Codes, LUU090HV ~ LUU420HV Outdoor Units

Figure 132: Location of LEDs in LUU090HV ~ LUU420HV Outdoor Units.

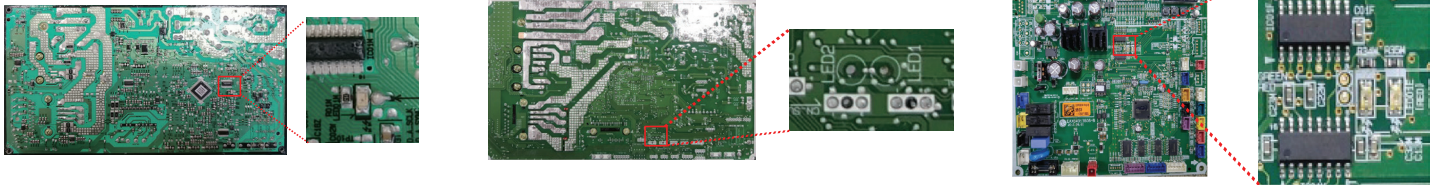

LUU090HV, LUU120HV

LUU180HV, LUU240HV

LUU360HV, LUU420HV

Figure 133: Example of Outdoor Unit Error Code 21 (DC Peak).

Example: Error 21 (DC Peak)

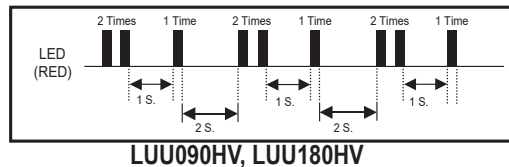

Example: Error 21 (DC Peak)

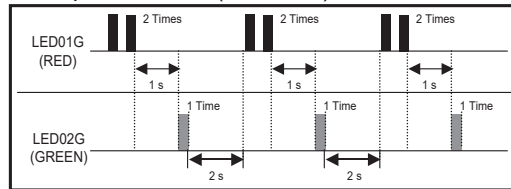

Note:

Outdoor unit errors can be checked on the LED of the wired remote controller (optional; sold separately), or the outdoor unit LED.

Note:

- The error code will shut the unit down, depending on the nature of the particular error code (it may or may not auto-restart).
- LED 1 blinks if error code number is in the double digits (tens place); LED 2 blinks if error code number is in the single digits (ones place).

Table 40: LUU090HV ~ LUU420HV Outdoor Unit Error Codes.

Error Code	Description	Wired Remote Controller Error Code	No. of Times ODU LEDs Blink		Frequency	Operation Status
			LED1 (Red)	LED2 (Green)		
21	DC Peak (IPM Fault); Compressor DC voltage was too high	CH21	2X	1X	10X in 1 Hour	Off
22	Current Transformer2 (CT2) error; Current AC input too high	CH22	2X	2X	Infinite Restart	Off
23	DC Link Error (High / Low DC Voltage)	CH23	2X	3X	Infinite Restart	Off
24	Pressure Switch / Heater Sink.	CH24	2X	4X	10X in 1 Hour	Off
26	DC Comp Position Error (not providing rotation), Locking	CH26	2X	6X	10X in 1 Hour	Off
27	PSC / PFC overcurrent error (HW); Current to inverter compressor too high	CH27	2X	7X	10X in 1 Hour	Off
29	Compressor phase overcurrent error	CH29	2X	9X	10X in 1 Hour	Off
32	Inverter Compressor Discharge Pipe (D-Pipe) Overheat	CH32	3X	2X	Infinite Restart	Off
35	Low Pressure Error	CH35	3X	5X		Off
41	Inverter Compressor Discharge Pipe Sensor is disconnected or shorted out	CH41	4X	1X	1X in 1 Hour	Off
43	High Pressure Sensor is disconnected or shorted out	CH43	4X	3X	1X in 1 Hour	Off
44	Outdoor inlet sensor is disconnected or shorted out	CH44	4X	4X	1X in 1 Hour	Off
45	Middle thermistor of outdoor unit condenser coil is disconnected or shorted out	CH45	4X	5X	1X in 1 Hour	Off
46	Outdoor unit suction pipe thermistor is disconnected or shorted out	CH46	4X	6X	1X in 1 Hour	Off
48	Outdoor unit condenser coil outlet (liquid piping) thermistor is disconnected or shorted out.	CH48	4X	8X	1X in 1 Hour	Off
51	Over Capacity	CH51	5X	1X	1X in 1 Hour	Off
53	Communication failure between outdoor unit and indoor unit	CH53	5X	3X	1X in 1 Hour	Off
54	Open Phase Error	CH54	5X	4X	1X in 1 Hour	Off
60	Outdoor unit printed circuit board (PCB) EEPROM check sum error	CH60	6X	-	1X in 1 Hour	Off
61	Outdoor unit condenser middle piping temperature is too high	CH61	6X	1X	Infinite Restart	Off
62	Outdoor unit inverter compressor PCB heat sink temperature is too high	CH62	6X	2X	Infinite Restart	Off
65	Outdoor unit heat sink thermistor has disconnected or has shorted out	CH65	6X	5X	1X in 1 Hour	Off
67	Outdoor brushless direct current (BLDC) fan motor lock error	CH67	6X	7X	10X in 1 Hour	Off
73	PSC / PFC overcurrent error (SW)	CH73	7X	3X	Infinite Restart	Off

CAUTIONS FOR REFRIGERANT LEAKS

Cautions for Refrigerant Leaks / Introduction

ASHRAE Standards 15-2010 and 34-2010 offer guidelines that address refrigerant safety and the maximum allowable concentration of refrigerant in an occupied space. Refrigerant will dissipate into the atmosphere, but a certain volume of air is required for this to occur safely. For R410A refrigerant, the maximum allowable concentration is 0.026 lbs./ft³ per 1,000 ft³ of air in an occupied space. Buildings with twenty-four (24) hour occupancy allow half of that concentration.¹

ASHRAE Standards 15 and 34 assume that if a system develops a leak, its entire refrigerant charge will dump into the area where the leak occurs. To meet ASHRAE Standards 15 and 34, calculate the refrigerant concentration that may occur in the smallest room volume on the system, and compare the results to the maximum allowable concentration number (see below for information on how to calculate the refrigerant concentration).¹ Also consult state and local codes in regards to refrigerant safety.

⚠ WARNING

Verify the maximum refrigerant concentration level in the space where the indoor unit will be mounted meets the concentration limit for the application. If the refrigerant leaks and safety limits are exceeded, it could result in personal injuries or death from oxygen depletion.

Note:

Take appropriate actions at the end of HVAC equipment life to recover, recycle, reclaim or destroy R410A refrigerant according to applicable US EPA rules.

To calculate the potential refrigerant concentration level (RCL):

1. Measure the occupied space dimensions (in feet).
2. Calculate the cubic foot volume of air in the smallest occupied space. (To obtain a detailed overview of the RCL, perform the same calculations to the second smallest zone, the third smallest zone until the RCL is obtained for all zones. Also, pay special attention to areas such as basements, etc., where refrigerant cannot dissipate easily.)
3. Divide the refrigerant charge of the Single Zone system serving the area in pounds by the results of step 1.
4. If the calculation indicates that the potential refrigerant concentration level is higher than the allowed RCL, increase the cubic volume of the smallest occupied space or modify the piping system design.
5. The allowable RCL limit for most applications must be equal to or less than 0.026 lbs./ft³. However, in special occupied spaces, such as hospitals and nursing homes, where occupants may have limited mobility, the allowable RCL limit is cut in half. See ASHRAE Standard 34-2007 and local codes for detailed information.¹

Refrigerant Concentration Limit (RCL) Calculations

To calculate total refrigerant amount per system:

Amount of Factory-Charged Refrigerant per Outdoor Unit	+	Amount of Additional Refrigerant Trim Charge	=	Total System Refrigerant Charge
---	---	---	---	--

$$\text{RCL (lbs./ft}^3\text{)} = \frac{\text{Total System Refrigerant Charge (lbs.)}}{\text{Volume of Smallest Occupied Space (ft}^3\text{)}}$$

¹American Society of Heating, Refrigeration and Air Conditioning Engineers, Inc. (ASHRAE). Atlanta, GA. ASHRAE, Inc. Information about ASHRAE Standard 15-2010 / 34-2010 and addenda current as of the date of this publication.

INSTALLATION CHECKLIST

Major Component Rough-In

Description	Check
Single Zone outdoor unit was connected properly per local code and the product installation procedures.	
All literature and bagged accessories have been removed from the fan discharge.	
Indoor unit was installed, properly supported, and located indoors in a non-corrosive environment.	
Single Zone unit's condensate drain line was connected and routed where it properly drains away or, if installed in a mechanical room, was connected and properly routed to a drain terminal.	

Piping and Insulation

Description	Check
Single-zone and multi-zone duct-free split systems: ACR copper piping rated at the system working pressure for R410A was used.	
All refrigerant pipes and valves were insulated separately. Insulation is positioned up against the walls of the indoor unit. No gaps shown. Insulation was not compressed at clamps and hangers.	

Brazing Practices

Description	Check
Medical grade (there are 4 available) dry nitrogen for purging during brazing was used (constant 3 psi while brazing).	
15% silver brazing material only.	

Refrigerant Piping

Description	Check
All pipe materials were properly stored, capped, and clean. All burrs were removed after cutting and pipe ends were reamed before brazing.	
During refrigerant pipe installation, for each segment of pipe, a record was made of the pipe length (including expansion loops, offsets, double-back sections), and sizes, as well as the quantity and type of elbows used.	
Expansion loops, coils or other acceptable measures are provided where necessary to absorb temperature-change based pipe movement.	
A torque wrench and backup wrench were used to tighten all flare connections.	
The back side of all flares were lubricated with a small drop of PVE refrigeration oil before tightening flare fittings.	
Ensure all field made flares are 45°. Use factory-supplied flare nuts only.	
Pipe segments were secured to the structure using a combination of fixed and floating clamps, and all wall penetrations were sleeved.	
Pipe insulation was not compressed at any point.	
No oil traps, solenoid valves, sight glasses, filter driers, or any other unauthorized refrigerant specialties were present.	
(Optional) High quality R-410A rated full port ball valves (Schrader between the valve body and the indoor units) used at the indoor unit and at will in the refrigerant piping.	

Condensate Pump / Drain Installation

Description	Check
Condensate drain installed on indoor units. Extended condensate piping material used is acceptable under local code. Insulated to prevent condensation.	
Indoor unit condensate drain pipes were installed correctly.	
Indoor unit with a gravity drain were level or slightly canted toward the drain connection and is supported properly.	
Drain lines are properly insulated to prevent condensation.	

Power Wire and Communication Cables

Description	Check
Power wiring to the Single Zone outdoor unit is solid or stranded, and complies with all local and national electrical codes.	
Power wiring was connected to a single phase 208-230V source.	
Ground wire was installed and properly terminated at the unit.	
The power supplied was clean with voltage fluctuations within specifications. ($\pm 10\%$ of nameplate).	
Power wiring to the Single Zone outdoor unit was installed per all local electrical code requirements.	
Communication / connection (power) cable from the single zone outdoor unit to the indoor unit must use a minimum of 14 AWG, four (4) conductor, stranded, shielded or unshielded (if shielded, it must be grounded to the chassis of the outdoor unit only), and must comply with applicable local and national codes.	
Use of 14 AWG, four (4) conductor, stranded, shielded or unshielded wire is allowed for lengths up to the published maximum pipe length, plus recommended slack at both ends.	
Wiring to the indoor unit was installed per all local electrical code requirements.	
Communication / connection (power) wiring from the outdoor unit to the indoor unit can be run in the same conduit.	
Communication type RS-485-BUS type.	
22-3 AWG, twisted, stranded, unshielded cable (minimum) was used between the indoor unit and its zone controller (if present). No cables were spliced, and no wire caps are present.	
LG-supplied cable was used between the indoor unit and its zone controller. No cables were spliced and no wire caps are present.	
Appropriate crimping tool was used to attach ring or spade terminals at all power wiring and control cable terminations.	
Power and control wires were run in the same conduit (outdoor unit to indoor only) as provided in the product installation manual.	
Power to outdoor unit and power/communications to indoor unit CANNOT be run in the same conduit.	

Checklists

Inverter

162279

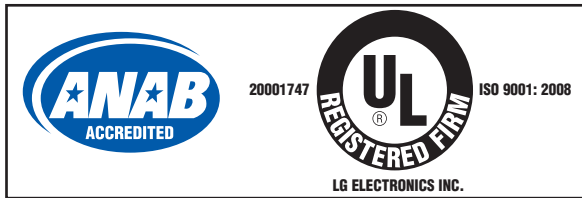

LG Electronics, U.S.A., Inc.
Air Conditioning Technologies
4300 North Point Parkway
Alpharetta, Georgia 30022
www.lghvac.com