

HORIZONTAL BASIC

LH-B/200 - 300 CFM

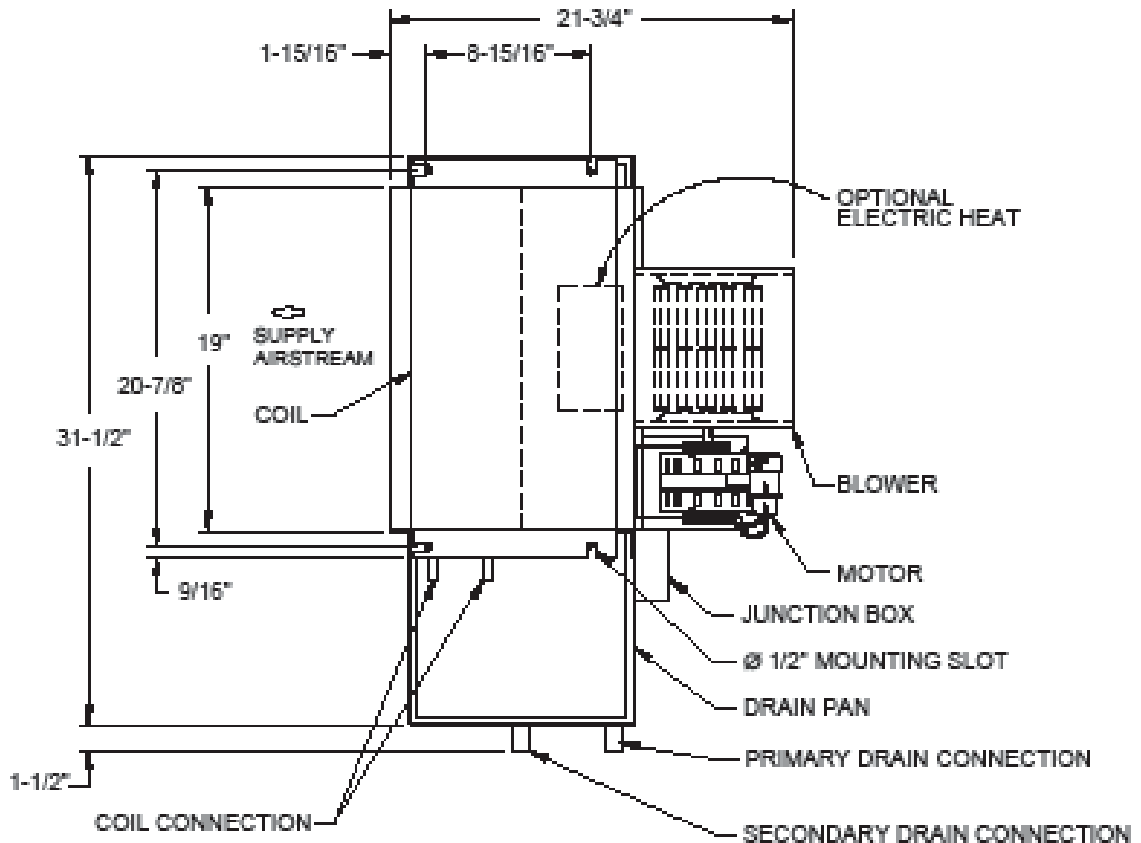

TOP VIEW

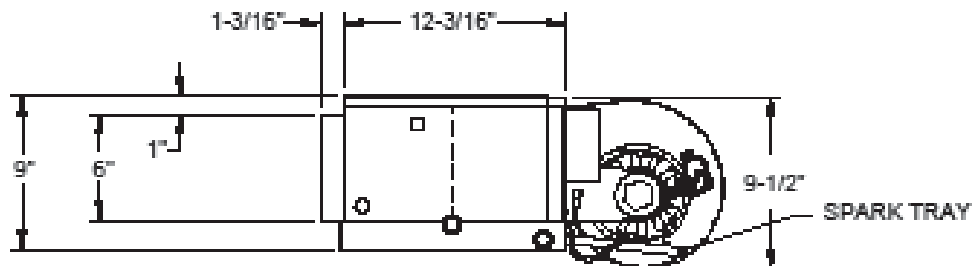

SIDE VIEW

- Right hand unit shown, left hand unit opposite.
- Coil connections determined by facing the supply air opening.
- Electrical junction box is located on the same side as the coil connections.
- Unit must be installed level and condensate drain lines should be trapped.
- Drain pan is powder coated epoxy with a 1/8" thick closed-cell insulation and has 3/4" NPT primary and secondary drain connections.
- Entire cabinet, scroll and blower wheel are heavy gauge, galvanized steel.
- Coil connections: 1/2" CW and HW on 002-003.

HORIZONTAL BASIC

LH-B/400 - 1,200 CFM

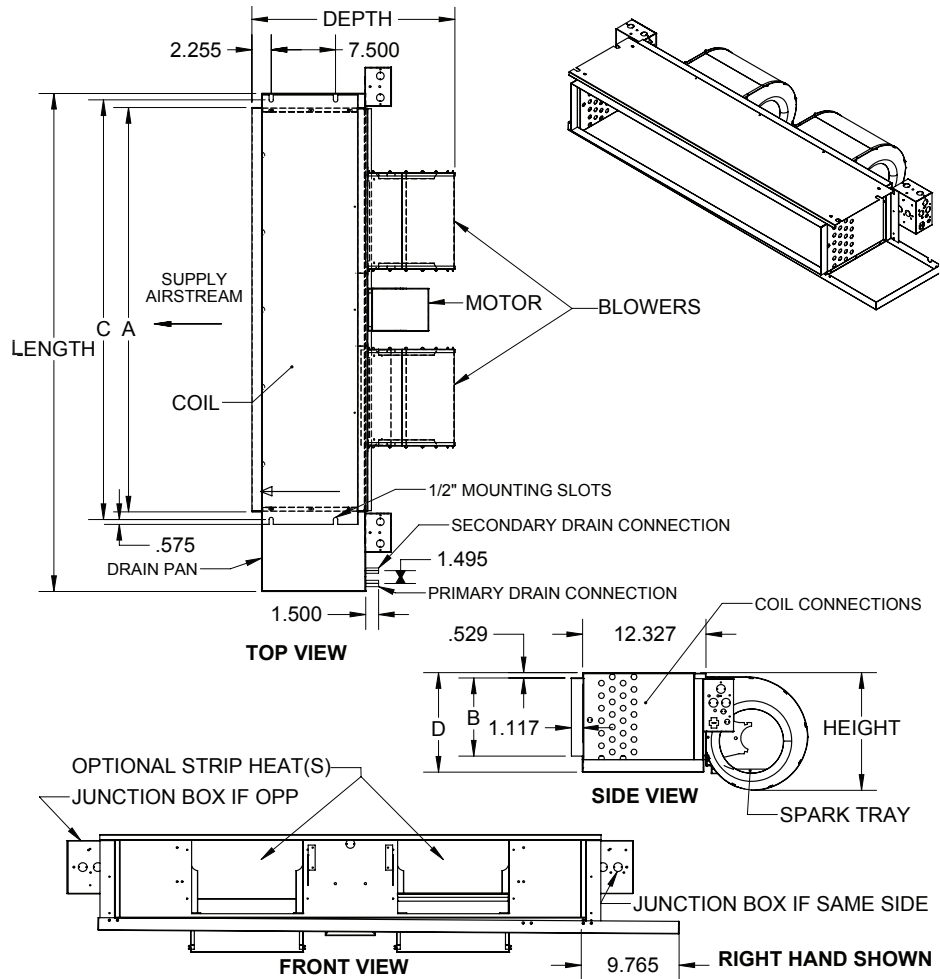

UNIT SIZE	OVERALL			SUPPLY DUCT				BLOWERS
	LENGTH	HEIGHT	DEPTH	A	B	C	D	
004	37.5	9.88	22.5	25.13	6	26.88	8	2
006	44	9.88	22.5	33.13	6	34.88	8	2
008	44	11.75	23.63	33.13	7.75	34.88	9.75	2
010	50	11.75	23.63	39.13	7.75	40.88	9.75	2
012	58	11.75	23.63	47.13	7.75	48.88	9.75	2

- All sizes shown in inches.
- Right-hand unit shown, left hand unit opposite.
- Coil connections determined by facing the supply air opening.
- Electrical junction box is located on the same side as the coil connections.
- Unit must be installed level and condensate drain lines should be trapped.
- Drain pan is powder-coated epoxy with a 1/8" thick closed-cell insulation and has 3/4" NPT primary and secondary drain connections.
- Entire cabinet, scroll and blower wheel are heavy gauge, galvanized steel
- Coil connections: 1/2" CW on 004-006, 3/4" CW on 008-012 and 1/2" HW on 004-012.