



FORCE™



Gas Fired Cast Iron Water Boilers

Standard Features

- Offered exclusively by Ferguson®
- 84% AFUE – meets DOE 2021 regulations
- **NEW DESIGN!**
 - Can be piped from either side (industry standard locations)
 - Concealed controls and components
- Hydrolevel® Hydrostat™ 3200 combination high limit/circulator relay control
 - Built-in LWCO
 - Energy-saving thermal targeting software
 - Outdoor reset available (not included)
- Honeywell® S8610 electronic ignition control & Honeywell gas valve
- Grundfos® Alpha 2™ circulator
- Built-in draft diverter
- Drop-in replacement boiler in most installations

Technical Information

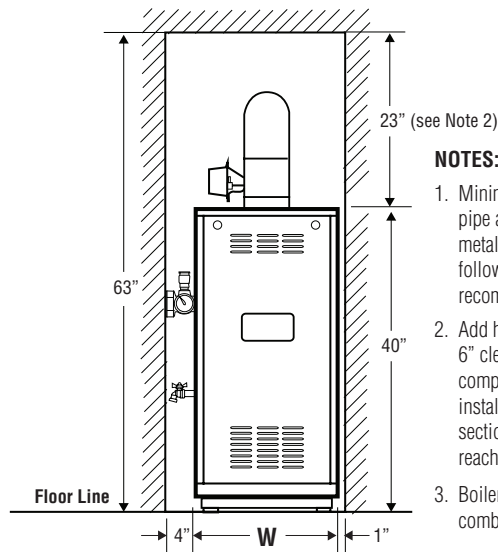
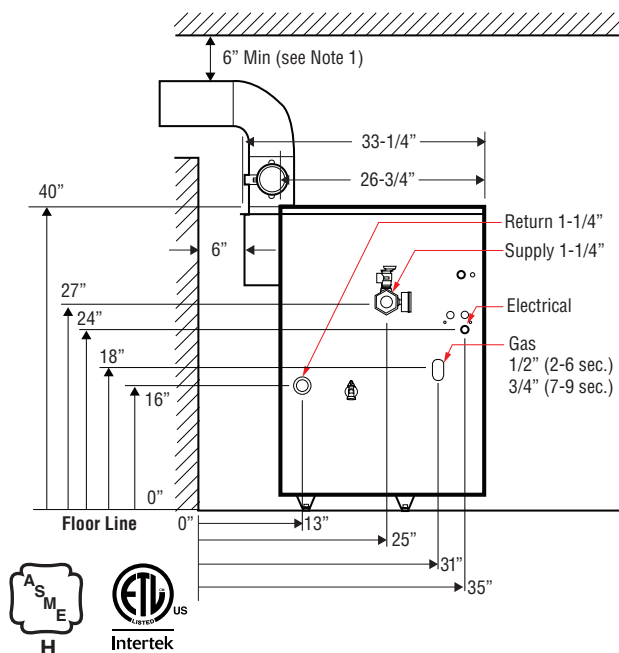

NOTES:

1. Minimal radial distance around vent pipe and breeching for single-wall metal pipe vent connector, otherwise follow vent connector manufacturer's recommended clearances.
2. Add height required to maintain 6" clearance from all breeching components. Vent damper may be installed in vertical or horizontal section of vent connector within reach of vent damper harness.
3. Boiler can be installed on combustible flooring



Model	Input ¹ (MBH)	DOE Heating Capacity (MBH)	Net AHRI Rating ² (MBH)	AFUE%	Flue Collar Diameter	Water Content (Gallons)	"W" Dimension (Inches)	Approx. Shipping Weight (lbs.)	Boiler Weight (lbs.)	ALT 1
FORCE02E	38	32	28	84.0	4	1	14	202	143	FORCE02ENRHG1
FORCE03E	68	57	50	84.0	4	2	14	254	180	FORCE03ENRHG1
FORCE04E	102	85	74	84.0	5	3	16	304	231	FORCE04ENRHG1
FORCE05E	136	114	99	84.0	6	4	19	357	284	FORCE05ENRHG1
FORCE06E	170	142	123	84.0	6	5	22	405	332	FORCE06ENRHG1
FORCE07E	204	170	148	84.0	7	6	25	462	382	FORCE07ENRHG1
FORCE08E	238	199	173	84.0	7	7	28	518	438	FORCE08ENRHG1
FORCE09E	272	227	197	84.0	8	8	31	564	484	FORCE09ENRHG1

All dimensions and specifications are subject to change without notice.

- 1 Input ratings can be used for elevations up to 2,000 ft. Refer to System Start-up and Checkout section of IO&S Manual for ratings above 2,000 ft.
- 2 Net AHRI water ratings shown are based on a piping and pickup allowance of 1.15. The manufacturer should be consulted before selecting a boiler for installations having unusual piping and pickup requirements, such as intermittent system operation, extensive piping, etc.

Additional Standard Features

- Reliable cast iron heat exchanger
- Steel nipples
- Limited lifetime warranty on heat exchanger, one year manufacturer's warranty on parts
- Automatic vent damper
- Roll-out switch, spill switch, ASME relief valve (30 PSI)
- Trapezoidal legs with nylon glides – permit easy positioning during installation

Boiler Conversion Kits (0-2,000 ft. altitude)

Natural Gas	Standard – from factory
LP Gas	110197-01 (2 sections)
	109874-01 (3-6 sections)
	109874-02 (7-9 sections)



FERGUSON[®]
Nobody expects more from us than we do[®]