

IL SERIES

MORE HEAT FOR LESS MONEY

InfraSave
radiant heaters

A

High Performance Ceramic Tile provides cleaner combustion. Indented surface increases heat emitting surface area.

B

Aluminized Steel Burner Housing resists corrosion and is durable for long life cycle.

C

Stainless Steel Tile Retainers withstands high temperatures for longevity.

D

Direct Spark Ignition for each burner panel provides safe operation and fuel economy.

E

Balanced Suspension Points to simplify mounting and reduce installation costs.

comfort and economy

The IL Series provides energy efficiency and productive working comfort

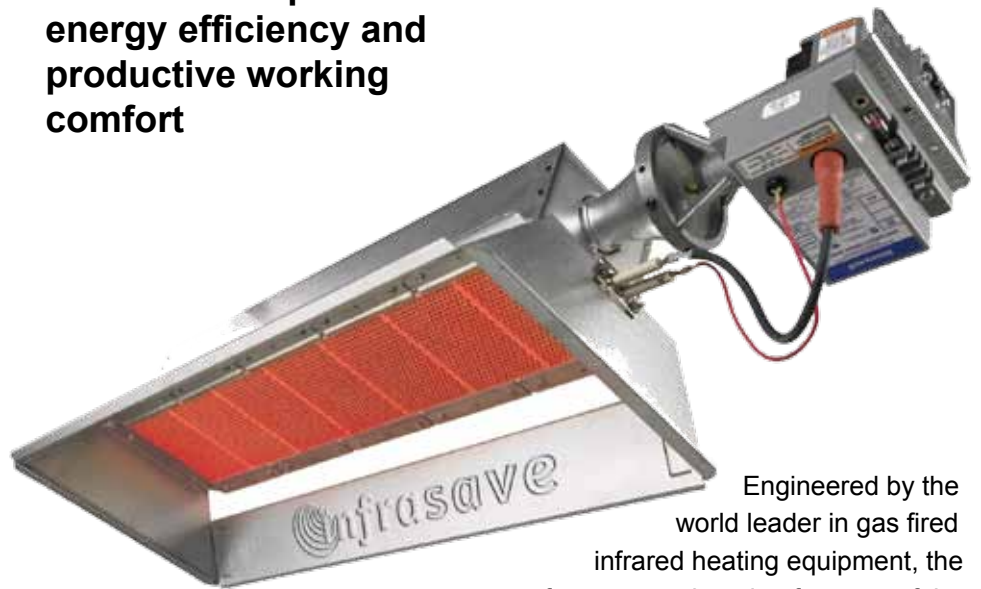

Engineered by the world leader in gas fired infrared heating equipment, the performance enhancing features of the IL Series luminous (high intensity) heater provide a quick return on investment. Exceptional infrared heat output yields economy of operation and improved work space comfort. Durable construction with no moving parts means years of low maintenance and trouble-free operation.

Perfect for space and spot heating, the IL shines in warehouses, manufacturing facilities, aircraft hangars, loading docks, and sports arenas. With firing capacities from 21,500 to 200,000 Btuh and the best warranty in the industry, you'll find an IL heater to suit your application and your budget.

So don't settle for an under performing luminous heater, set your sights on the efficiency and fuel savings generated by the InfraSave IL Series.

Don't settle for an underperforming infrared heater. InfraSave provides more heat for less money.

IL Series Specifications

Dimensions and Specifications

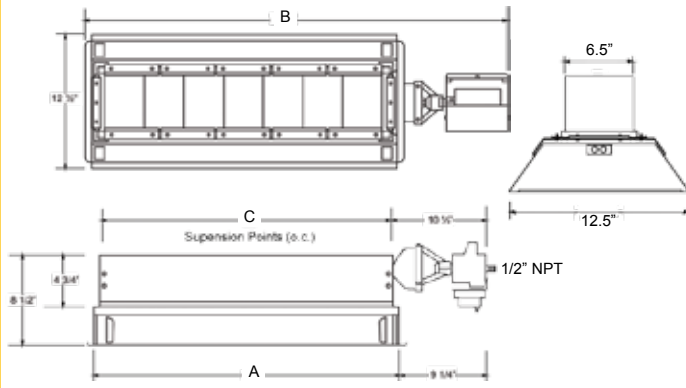

Gas Pressure	Line min.:	6" W.C. NG	11" W.C. LP
	Line max.:	14" W.C. NG	14" W.C. LP
Gas inlet	Manifold:	5" W.C. NG	10" W.C. LP
		1/2" NPT	

MODEL	DIMENSIONS			INPUT BTU/HR	WEIGHT (LBS)	ELECT.
	A	B	C			
IL-X-25	13.50"	24"	11.3"	21,500	22	24 VAC 60 Hz 0.55 A.
IL-X-37	20.50"	30.3"	15.5"	35,000	26	
IL-X-50	28.00"	38.5"	18.5"	50,000	31	
IL-X-75	38.75"	48.5"	29.5"	65,000	38	
IL-X-100	53.25"	63.8"	44"	100,000	45	

Clearances to Combustibles

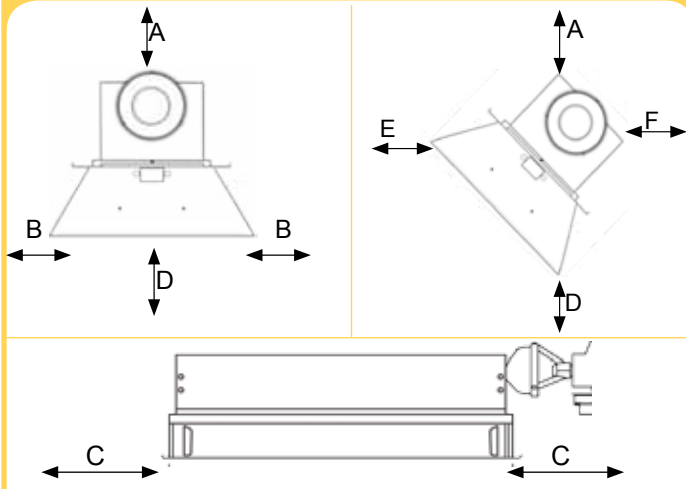

MODEL	SUSPENDED HORIZONTALLY				SUSPENDED AT AN ANGLE UP TO 30°	
	A	B	D	C	E	F
IL-X-25	24"	27"	60"	24"	60"	24"
IL-X-37	24"	27"	60"	24"	60"	24"
IL-X-50	24"	27"	78"	24"	78"	24"
IL-X-75	30"	33"	84"	30"	84"	30"
IL-X-100	36"	33"	84"	30"	84"	30"

Distributor info:

Infrasave
radiant heaters
Luminous Heater Series



Infrasave
radiant heaters
Tube Heater Series



Infrasave
radiant heaters
Patio Heater Series

