

INSTALLATION, OPERATING AND SERVICE INSTRUCTIONS FOR

MegaSteam™ 3-PASS OIL BOILER

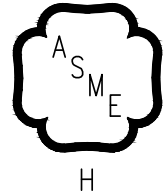

As an ENERGY STAR® Partner, U.S. Boiler Company has determined that the MST288, MST396, MST513 and MST629 meet the ENERGY STAR® guidelines for Energy efficiency established by the United States Environmental Protection Agency (EPA).



For service or repairs to boiler, call your heating contractor or oil supplier. When seeking information on boiler, provide Boiler Model Number and Serial Number as shown on Rating Label located on top of the boiler.

Boiler Model Number MST	Boiler Serial Number	Installation Date
Heating Contractor		Phone Number
Address		



IMPORTANT INFORMATION - READ CAREFULLY

All boilers must be installed in accordance with National, State and Local Plumbing, Heating and Electrical Codes and the regulations of the serving utilities. These Codes and Regulations may differ from this instruction manual. Authorities having jurisdiction should be consulted before installations are made.

In all cases, reference should be made to the following Standards:

USA BOILERS

- A. Current Edition of American National Standard ANSI/NFPA 31, "Installation of Oil Burning Equipment", for recommended installation practices.
- B. Current Edition of American National Standard ANSI/NFPA 211, "Chimneys, Fireplaces, Vents, and Solid Fuel Burning Appliances", For Venting requirements.
- C. Current Edition of American Society of Mechanical Engineers ASME CSD-1, "Controls and Safety Devices for Automatically Fired Boilers", for assembly and operations of controls and safety devices.
- D. All wiring on boilers installed in the USA shall be made in accordance with the National Electrical Code and/or Local Regulations.

The following terms are used throughout this manual to bring attention to the presence of hazards of various risk levels, or to important information concerning product life.

DANGER

Indicates an imminently hazardous situation which, if not avoided, will result in death, serious injury or substantial property damage.

CAUTION

Indicates a potentially hazardous situation which, if not avoided, may result in moderate or minor injury or property damage.

WARNING

Indicates a potentially hazardous situation which, if not avoided, could result in death, serious injury or substantial property damage.

NOTICE

Indicates special instructions on installation, operation, or maintenance which are important but not related to personal injury hazards.

NOTICE

This boiler has a limited warranty, a copy of which is included with this boiler.

The warranty for this boiler is valid only if the boiler has been installed, maintained and operated in accordance with these instructions.

Surface rust on cast iron sections may be attributed to the manufacturing process as well as condensation during storage. Surface rust is normal and does not affect the performance or longevity of a boiler.

DANGER

DO NOT store or use gasoline or other flammable vapors or liquids in the vicinity of this or any other appliance.

WARNING

Improper installation, adjustment, alteration, service or maintenance can cause property damage, personal injury or loss of life. Failure to follow all instructions in the proper order can cause personal injury or death. Read and understand all instructions, including all those contained in component manufacturers manuals which are provided with the boiler before installing, starting-up, operating, maintaining or servicing this boiler. Keep this manual and literature in legible condition and posted near boiler for reference by owner and service technician.

This boiler requires regular maintenance and service to operate safely. Follow the instructions contained in this manual.

Installation, maintenance, and service must be performed only by an experienced, skilled and knowledgeable installer or service agency.

All heating systems should be designed by competent contractors and only persons knowledgeable in the layout and installation of hydronic heating systems should attempt installation of any boiler.

Installation is not complete unless a safety valve is installed into 1½" x ¾" NPT reducing bushing, mounted into rear section boss, at the back of rear section. See Unit-Pak Boiler Assembly and Steam Boiler Trim & Piping Sections of this manual for details.

It is the responsibility of the installing contractor to see that all controls are correctly installed and are operating properly when the installation is completed.

This boiler is suitable for installation on combustible flooring. Do not install boiler on carpeting.

Do not tamper with or alter the boiler or controls.

Inspect flueways at least once a year - preferably at the start of the heating season. The inside of the combustion chamber, the vent system and boiler flueways should be cleaned if soot or scale has accumulated.

When cleaning this boiler, take precaution to avoid damage to burner swing door insulation. If damaged, or if there is evidence of previous damage, burner swing door insulation must be replaced immediately.

Oil Burner and Controls must be checked at least once a year or as may be necessitated.

Do not operate boiler with jumpered or absent controls or safety devices.

Do not operate boiler if any control, switch, component, or device has been subject to water.

Appliance materials of construction, products of combustion and the fuel contain alumina, silica, heavy metals, carbon monoxide, nitrogen oxides, aldehydes and/or other toxic or harmful substances which can cause death or serious injury and which are known to the state of California to cause cancer, birth defects and other reproductive harm. Always use proper safety clothing, respirators and equipment when servicing or working nearby the appliance.

WARNING

This boiler contains very hot water under high pressure. Do not unscrew any pipe fittings nor attempt to disconnect any components of this boiler without positively assuring the water is cool and has no pressure. Always wear protective clothing and equipment when installing, starting up or servicing this boiler to prevent scald injuries. Do not rely on the pressure and temperature gauges to determine the temperature and pressure of the boiler. This boiler contains components which become very hot when the boiler is operating. Do not touch any components unless they are cool.

This boiler must be properly vented. The chimney must be inspected for any obstructions and cleaned prior to each heating season. A clean and unobstructed chimney flue is necessary to produce the minimum draft required to safely evacuate noxious fumes that could cause personal injury or loss of life. Evidence of loose debris and or condensate induced stains at the base of the chimney flue, connector or smokepipe joints may be signs of condensing flue gases. Flue gas condensate is corrosive, which requires special consideration and must be addressed immediately. Refer to Section V, "Venting and Air Intake Piping".

This boiler needs fresh air for safe operation and must be installed so there are provisions for adequate combustion and ventilation air.

This boiler is supplied with controls which may cause the boiler to shut down and not re-start without service. If damage due to frozen pipes is a possibility, the heating system should not be left unattended in cold weather; or appropriate safeguards and alarms should be installed on the heating system to prevent damage if the boiler is inoperative.

This boiler is designed to burn No. 2 fuel oil only. Do not use gasoline, crankcase drainings, or any oil containing gasoline. Never burn garbage or paper in this boiler. Do not convert to any solid fuel (i.e. wood, coal). Do not convert to any gaseous fuel (i.e. natural gas, LP). All flammable debris, rags, paper, wood scraps, etc., should be kept clear of the boiler at all times. Keep the boiler area clean and free of fire hazards.

All boilers equipped with burner swing door have a potential hazard which, if ignored, can cause severe property damage, personal injury or loss of life. Before opening swing door, unplug burner power cord from receptacle located in lower right corner of jacket front panel and turn off service switch to boiler to prevent accidental firing of burner outside the combustion chamber. Be sure to tighten swing door fasteners completely when service is completed.

TABLE OF CONTENTS

I. Pre-Installation	7	VIII. System Start-Up	41
II. Unit-Pak Boiler Assembly	9	IX. Maintenance & Service Instructions	47
III. Steam Boiler Piping & Trim.....	24	X. Boiler Cleaning	50
IV. Tankless & Indirect Water Heater Piping.....	26	XI. Trouble Shooting	52
V. Venting & Air Intake Piping	29	XII. Repair Parts.....	54
VI. Electrical	33	Appendix A - Figures.....	67
VII. Oil Piping	39	Appendix B - Tables.....	69

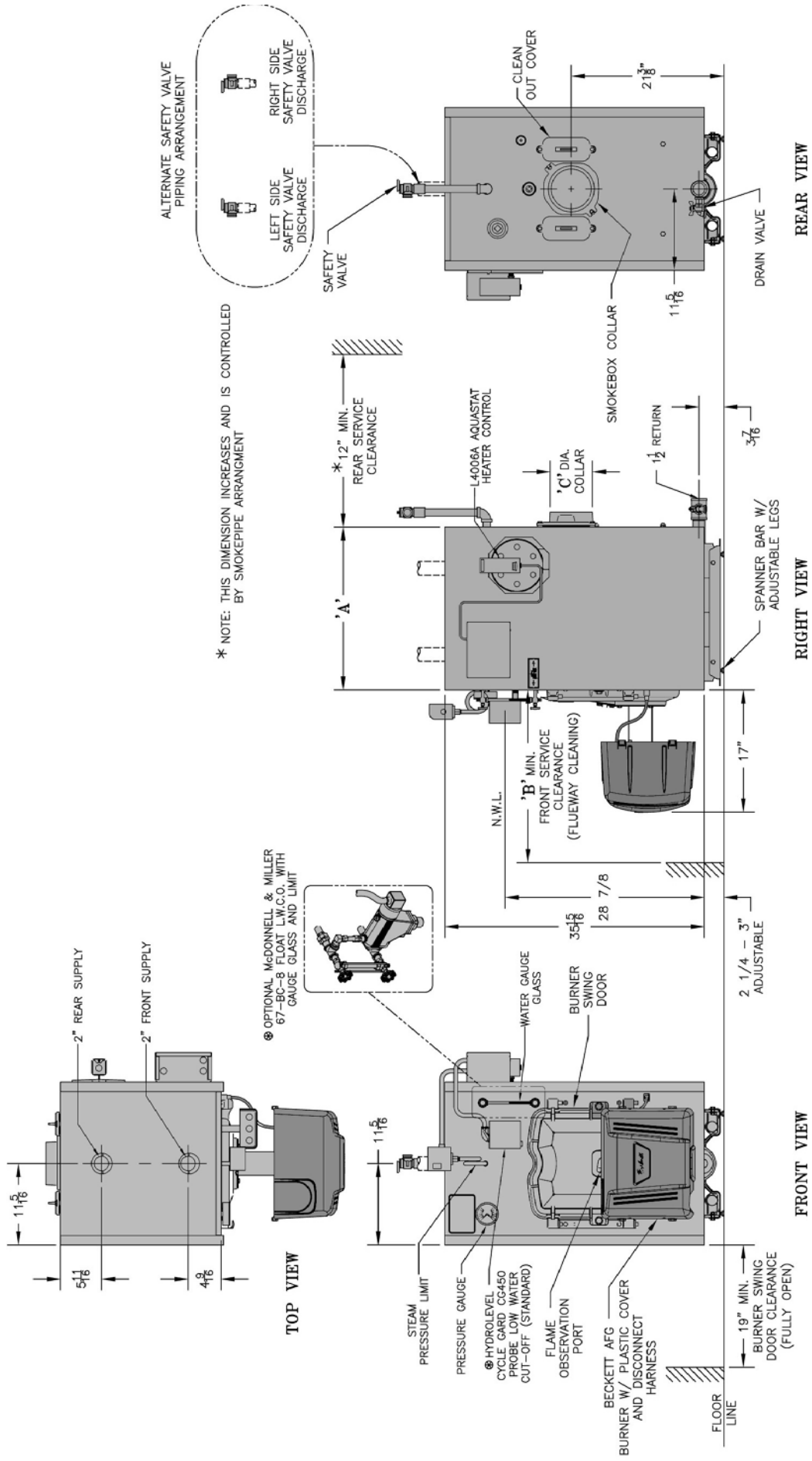

Figure 1: MST288 Thru MST629 Steam Boiler with and without Tankless Heater (Beckett Burner Shown)

TABLE 1A: DIMENSIONAL DATA (SEE FIGURE 1)

Boiler Model No.	Dimensions (See Figure 1)			Water Content (To Normal Water Line) - Gallons		Heat Transfer Surface Area - sq. Ft.	Actual Shipping Weight (LB.)
	"A"	"B"	"C"	With Tankless Heater	Non-Heater		
MST288	22-5/8"	24"	6"	15.3	14.9	20.29	607
MST396	22-5/8"	24"	6"	15.3	14.9	20.29	607
MST513	28-5/8"	30"	6"	19.7	19.3	27.29	744
MST629	34-5/8"	36"	7"	24.1	23.8	34.29	881

NOTE: 1: Maximum Working Pressure: Steam - 15 PSI

TABLE 1B: RATING DATA

Boiler Model No.	Burner Capacity			AHRI NET Ratings		Minimum Chimney Requirements			AFUE %
	GPH	MBH	DOE Heating Capacity MBH	Steam MBH	Steam Sq. Ft.	Round In. Dia.	Rectangle In. x In.	Height Ft.	
MST288	0.75	105	92	69	288	6	8 X 8	15	86.0
MST396	1.05	147	127	95	396	6	8 X 8	15	86.0
MST513	1.35	189	164	123	513	7	8 X 8	15	86.0
MST629	1.65	231	201	151	629	7	8 X 8	15	86.0

SECTION I: PRE-INSTALLATION

A. INSPECT SHIPMENT carefully for any signs of damage.

1. All equipment is carefully manufactured, inspected and packed. Our responsibility ceases upon delivery of crated boiler to the carrier in good condition.
2. Any claims for damage or shortage in shipment must be filed immediately against the carrier by the consignee. No claims for variances from, or shortage in orders, will be allowed by the manufacturer unless presented within sixty (60) days after receipt of goods.

B. LOCATE BOILER in front of final position before removing crate. See Figure 1.

1. LOCATE so that vent pipe connection to chimney will be short and direct.
2. BOILER IS SUITABLE FOR INSTALLATION ON COMBUSTIBLE FLOOR. Boiler cannot be installed on carpeting.
3. FOR BASEMENT INSTALLATION, provide a solid elevated base, such as concrete, if floor is not level, or if water may be encountered on floor around boiler.
4. PROVIDE RECOMMENDED SERVICE CLEARANCE, if applicable, as follows:

- a. Clearance from Jacket Front Panel -
 - 24" for servicing burner
 - 24" for flueway cleaning (MST288 & MST396)

- 30" for flueway cleaning (MST513)
 - 36" for flueway cleaning (MST629)
- b. Clearance from Jacket Left Side Panel -
 - 19" for burner swing door, if opened fully with burner mounted, otherwise 1" with burner removed
 - 12" access clearance to service rear of boiler if right side clearance is less than 12"
 - 1" minimum if right side clearance is 12" or larger to access and service rear of boiler.
 - c. Clearance from Jacket Right Side Panel -
 - 6" minimum from external Electrical Enclosure if left side clearance is 12" or larger to access and service rear of the boiler
 - 24" minimum from rear tankless heater (if equipped) for servicing and removal of the heater
 - d. Clearance from Jacket Rear Panel -
 - 12" minimum for rear smokebox cleaning (Note: This dimension will also be controlled by horizontal to vertical to horizontal smokepipe arrangement - See Figures 2 and 15.)
5. For minimum clearances to combustibile materials. See Figure 2.

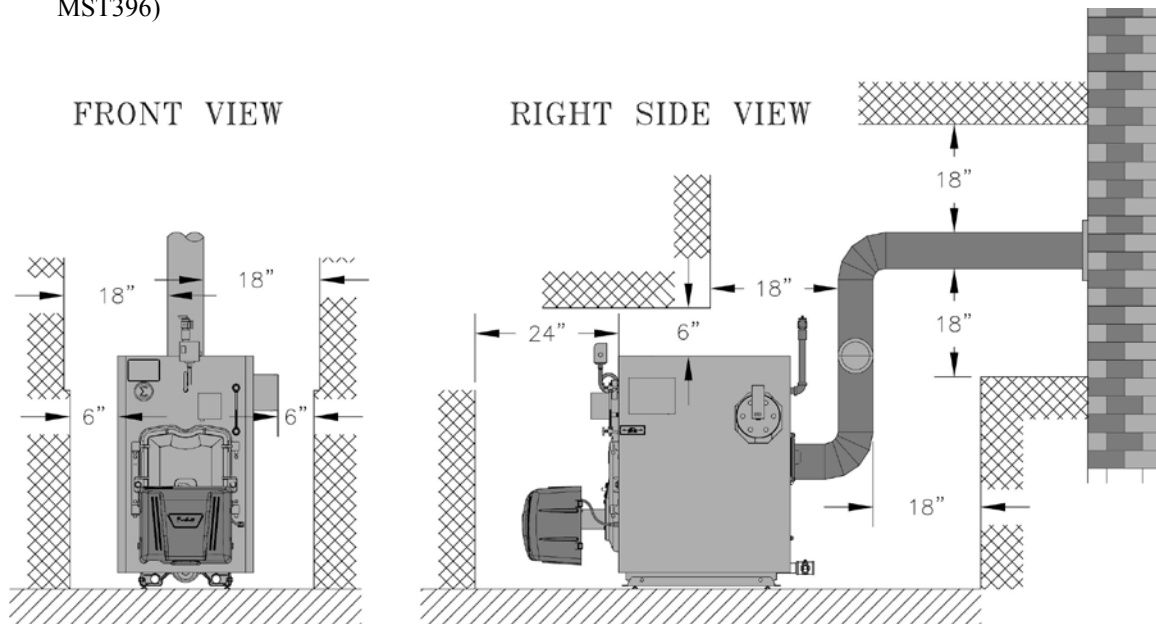

Figure 2: Minimum Installation Clearances To Combustible Materials (Inches)

NOTES:

1. Listed clearances comply with American National Standard ANSI/NFPA 31, Installation of Oil Burning Equipment.
2. MegaSteam™ boilers can be installed in rooms with clearances from combustibile material as listed above.

- Listed clearances cannot be reduced for alcove or closet installations.
3. For reduced clearances to combustibile material, protection must be provided as described in the above ANSI/NFPA 31 standard.

SECTION I: PRE-INSTALLATION (continued)

NOTICE

Clearance to venting is for single wall vent pipe. If Type L vent is used, clearance may be reduced to the minimum required by the vent pipe manufacturer.

C. PROVIDE COMBUSTION AND VENTILATION

AIR. Local and National Codes may apply and should be referenced.

WARNING

Adequate combustion and ventilation air must be provided to assure proper combustion and to maintain safe ambient air temperatures.

Do not install boiler where gasoline or other flammable vapors or liquids, or sources of hydrocarbons (i.e. bleaches, fabric softeners, etc.) are used or stored.

Do not install boiler in laundry room, or, in vicinity of clothes dryer to prevent inadequate air supply to burner and lint contamination of burner air intake openings.

1. Determine volume of space (boiler room). Rooms communicating directly with the space in which the appliances are installed, through openings not furnished with doors, are considered a part of the space.
$$\text{Volume}(\text{ft}^3) = \text{Length}(\text{ft}) \times \text{Width}(\text{ft}) \times \text{Height}(\text{ft})$$
2. Determine total input of all appliances in the space. Add inputs of all appliances in the space and round the result to the nearest 1000 BTU per hour.
3. Determine type of space. Divide Volume by total input of all appliances in space. If the result is greater than or equal to 50 ft³/1000 BTU per hour, then it is considered an **unconfined space**. If the result is less than 50 ft³/1000 BTU per hour then the space is considered a **confined space**.
4. For boiler located in an *unconfined space of a conventionally constructed building*, the fresh air infiltration through cracks around windows and doors normally provides adequate air for combustion and ventilation.
5. For boiler located in a confined space or an unconfined space in a building of **unusually tight construction**, provide outdoor air.
 - a. Outdoor air for combustion may be provided with an optional U.S. Boiler Company Fresh Air Accessory Kit, **(ONLY AVAILABLE**

WITH BECKETT BURNER). Metal cover applications, P/N 611280031. Plastic cover applications, P/N 102119-01. Refer to Fresh Air Accessory Kit Instructions for installation and air intake piping details.

or

- b. Outdoor air may be provided with the use of two permanent openings which communicate directly or by duct with the outdoors or spaces (crawl or attic) freely communicating with the outdoors. Locate one opening within 12 inches of top of space. Locate remaining opening within 12 inches of bottom of space. Minimum dimension of air opening is 3 inches. Size each opening per following:
 - i. **Direct communication with outdoors.** Minimum free area of 1 square inch per 4,000 BTU per hour input of all equipment in space.
 - ii. **Vertical ducts.** Minimum free area of 1 square inch per 4,000 BTU per hour input of all equipment in space. Duct cross-sectional area shall be same as opening free area.
 - iii. **Horizontal ducts.** Minimum free area of 1 square inch per 2,000 BTU per hour input of all equipment in space. Duct cross-sectional area shall be same as opening free area.
Alternate method for boiler located within confined space. Use indoor air if two permanent openings communicate directly with additional space(s) of sufficient volume such that combined volume of all spaces meet criteria for unconfined space. Size each opening for minimum free area of 1 square inch per 1,000 BTU per hour input of all equipment in spaces, but not less than 100 square inches.
6. Louvers and Grilles of Ventilation Ducts
 - a. All outside openings should be screened and louvered. Screens used should not be smaller than 1/4 inch mesh. Louvers will prevent the entrance of rain and snow.
 - b. Free area requirements need to consider the blocking effect of louvers, grilles, or screens protecting the openings. If the free area of the louver or grille is not known, assume wood louvers have 20-25 percent free area and metal louvers and grilles have 60-75 percent free area.
 - c. Louvers and grilles must be fixed in the open position, or interlocked with the equipment to open automatically during equipment operation.

SECTION II: UNIT-PAK BOILER ASSEMBLY

MegaSteam™ Unit-Pak Boiler Assembly Shipment

Content Check List (see Figure 3)

1. ___ **Cast Iron Section/Burner Swing Door/Smoke Box Assembly Mounted on Shipping Skid:**

- ___ MST3 (Rear Section, Heater) – Part # 100566-03 / 102417-01 / 100021-01
- ___ MST4 (Rear Section, Heater) – Part # 100566-04 / 102417-01 / 100021-01
- ___ MST5 (Rear Section, Heater) – Part # 100566-05 / 102417-02 / 100021-01
- ___ MST3 (Rear Section, Non-Heater) – Part # 100567-03 / 102417-01 / 100021-01
- ___ MST4 (Rear Section, Non-Heater) – Part # 100567-04 / 102417-01 / 100021-01
- ___ MST5 (Rear Section, Non-Heater) – Part # 100567-05 / 102417-02 / 100021-01

2. ___ **Control Carton**

- ___ CG450 LWCO; W/Tankless Heater - Part # 100608-01
- ___ PS801 LWCO; W/Tankless Heater - Part # 100622-01
- ___ #67 LWCO; W/Tankless Heater - Part # 100678-01
- ___ CG450 LWCO; L/Tankless Heater - Part # 100680-01
- ___ PS801 LWCO; L/Tankless Heater - Part # 100681-01
- ___ #67 LWCO; L/Tankless Heater - Part # 100679-01

3. ___ **Jacket Carton**

- ___ MST3 – Part # 100609-03
- ___ MST4 – Part # 100609-04
- ___ MST5 – Part # 100609-05

4. ___ **Part Carton**

- ___ MST3 & 4 - Part # 100615-01
- ___ MST5 - Part # 100629-01

5. ___ **Insulation Wrapper**

- ___ MST3 - Part #100614-03
- ___ MST4 - Part #100614-04
- ___ MST5 - Part #100614-05

6. ___ **Instruction/Label Bag**

- ___ MST (All Models) – Part # 100617-01

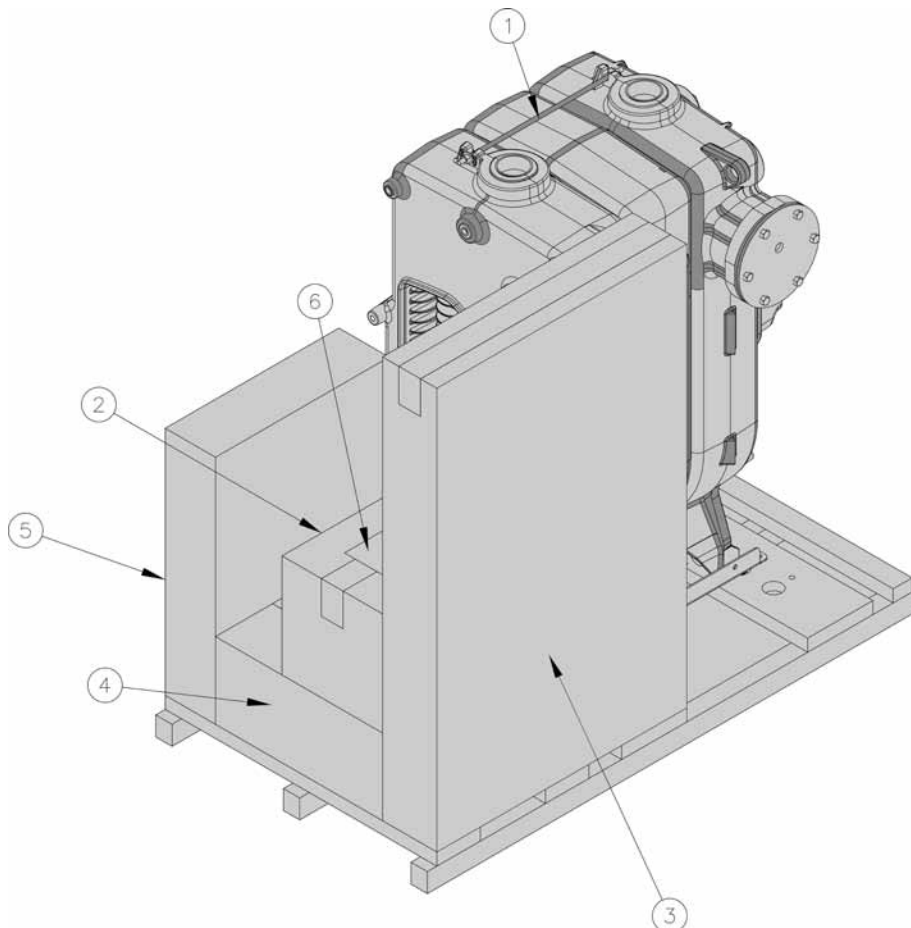

Figure 3: MegaSteam™ Unit-Pak Boiler Shipment Contents (outside container removed)

SECTION II: UNIT-PAK BOILER ASSEMBLY (continued)

A. CAST IRON SECTION ASSEMBLY TAPPINGS

Refer to Table 3 "Purpose of Tappings and Bosses" and Figure 7.

1. All tappings have factory installed thread protectors. The thread protectors must be removed prior to jacket and piping installation.
2. Depending on installation specifics and boiler build ordered, some tappings (front section Optional Front Return, rear section Indirect Heater Supply and Indirect Heater Limit) may not be used and must be plugged before jacket and piping installation. The appropriate size plugs for above mentioned tappings, as well as rear section Surface Blowoff and front section probe type LWCO tappings, are enclosed into Part Cartons (100615-01 or 100629-01) and Control Cartons (100678-01 and 100679-01), supplied as part of MegaSteam™ Unit-Pak Boiler shipment.

B. REMOVAL OF CAST IRON SECTION/ BURNER SWING DOOR / SMOKE BOX ASSEMBLY FROM SKID.

WARNING

The Cast Iron Section/Burner Swing Door/Smoke Box Assembly has a substantial weight. Insure the travel path to permanent location, as well as mounting surface at boiler permanent location, are structurally sound and rated to handle the boiler weight and water content (refer to Table 1A). Otherwise, a potentially hazardous situation could result in death, serious injury and substantial property damage.

1. Move crated Cast Iron Section/Burner Swing Door/Smoke Box Assembly and part cartons on the shipping skid as close to final permanent location as possible.
2. Remove all fasteners at crate skid. Lift outside container. Examine the skid contents for damage due to shipping and handling.
3. Remove Insulation Wrapper, Control Carton, Jacket Carton and Part Carton from skid and set aside.
4. Instruction/Label Bag is affixed to Section Assembly tie rod. Remove the bag and locate MegaSteam™ Boiler Installation, Operating and Service Instruction manual. READ AND UNDERSTAND ALL INSTRUCTIONS BEFORE ATTEMPTING BOILER HANDLING AND INSTALLATION.
5. The Cast Iron Section/Burner Swing Door/Smoke Box Assembly is secured to shipping skid with four lag screws. Remove the screws and discard.

6. For manual Cast Iron Section/Burner Swing Door/Smoke Box Assembly removal prepare one piece of 4" x 4" x 16" lg. (or two pieces of 2" x 4" x 16" lg.) and two pieces of 1" Sch. 40 black pipe to be used as handles. Suggested pipe length for each handle is 72" (3-section); 78" (4-section) and 84" (5-section).
7. Place wooden block(s) 12" from rear of skid as shown. See Figure 4 "Boiler Removal from Skid".
8. Insert 1" Sch. 40 black pipe handles thru leg holes in front and rear section legs. Center rear pipe ends on wooden block(s). See Figure 4.
9. For best leverage, the pipe handles should extend 48" minimum beyond front section face.
10. Using the pipe handles, lift the Cast Iron Section/Burner Swing Door/Smoke Box Assembly until adjustable legs are elevated above the skid deck boards.
11. Remove the skid from underneath the Cast Iron Section/Burner Swing Door/Smoke Box Assembly.
12. Lower pipe handles until front adjustable legs touch the floor. Place wood blocks under front legs, if required, before lowering, to provide hand clearance.
13. To lower rear of the Cast Iron Section/Burner Swing Door/Smoke Box Assembly tilt boiler slightly forward by pushing on smokebox, or, lift pipes protruding thru rear legs, until wooden block(s) can be removed (see Figure 4). Slowly allow the weight of boiler to tilt backward until rear legs rest on floor.
14. If wood blocks were placed under front legs, lift pipe handles; remove the blocks and lower front legs to floor. Remove pipe handles.
15. Move Cast Iron Section/Burner Swing Door/Smoke Box Assembly to permanent position by sliding or walking.

CAUTION

Do not drop boiler when removing from skid and moving to permanent position.

C. PROCEDURE TO OPEN, CLOSE AND SECURE BURNER SWING DOOR.

Throughout this manual you will be instructed to open and close Burner Swing Door for various reasons. There is a proper and improper method of closing and securing the door opened for front jacket panel installation, inspection, cleaning or field service. Refer to Figures 5A, 5B, 5C and paragraphs D "Jacket Front Panel Installation", and, F "Closing/Securing Burner Swing Door" for details.

SECTION II: UNIT-PAK BOILER ASSEMBLY (continued)

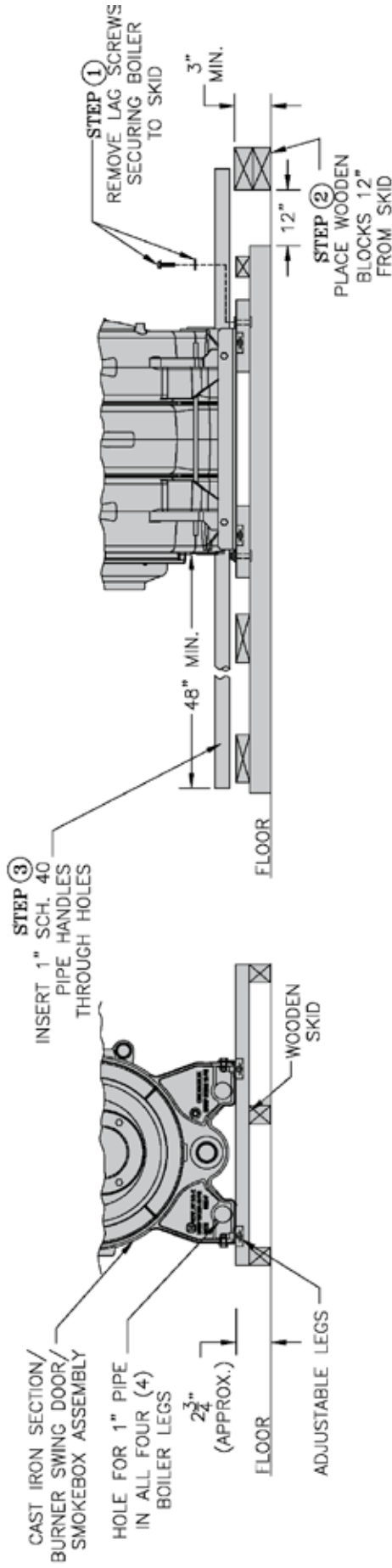

PARTIAL FRONT VIEW

PARTIAL SIDE VIEW NO. 1

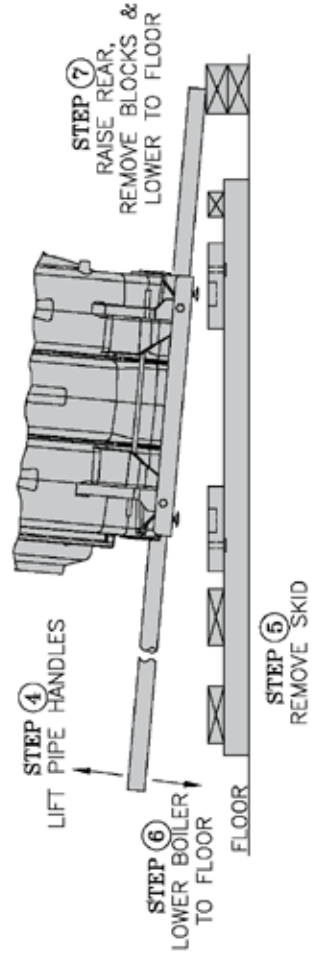

PARTIAL SIDE VIEW NO. 2

Figure 4: Boiler Removal from Skid

SECTION II: UNIT-PAK BOILER ASSEMBLY (continued)

D. JACKET FRONT PANEL INSTALLATION.

In order to install front jacket panel Burner Swing Door and door mounting bracket need to be removed. As shipped, the door would open to the left side.

1. To open/remove Burner Swing Door (mounted on Cast Iron Section/Burner Swing Door/Smoke Box Assembly) and door mounting bracket for front jacket panel installation:
 - a. Loosen but not remove door left side latching hardware (3/8"-16 x 1-3/4" tap bolt).
 - b. Loosen and remove door right side latching hardware (3/8"-16 x 1-3/4" tap bolt and 5/16" washer) and set aside.
 - c. Remove door left side latching hardware (3/8"-16 x 1-3/4" tap bolt and 5/16" washer) and set aside.
 - d. Lift the door off mounting bracket and set aside.
 - e. Remove two 5/16"-18 - 3/4" hex head cap screws securing door mounting bracket to front section and set aside.
 - f. Remove door mounting bracket and set aside.
 - g. Note/mark cap screw bosses on front section left side; locate/mark similar two bosses directly opposite on front section right side. These four front section bosses are front jacket panel and door mounting bracket attachment points.

See also Figure 7 "Purpose of Tappings & Bosses".

2. Open Jacket Carton and locate jacket front panel (has factory attached 1" fiberglass insulation). See also "Repair Parts" Section, "Jacket Assembly" illustration for part identification.
3. Open Part Carton, locate Hardware Bag, remove two 5/16"-18 x 1/2" Phillips pan head machine screws.
4. Place front jacket panel over front section attachment bosses and align jacket holes with front section boss holes.
5. Firstly, install two 5/16"-18 x 1/2" Phillips pan head machine screws hand tight to secure front jacket panel right side to casting
6. Secondly, insert 5/16"-18 - 3/4" hex head cap screw thru door mounting bracket upper hole and upper hole on left side of front jacket panel simultaneously, and, fasten the bracket and panel to casting hand tight.
7. Thirdly, insert 5/16"-18 - 3/4" hex head cap screw thru door mounting bracket lower hole and lower hole on left side of front jacket panel simultaneously, and, fasten the bracket and panel to casting hand tight.
8. Finally, tighten both sets of hardware to secure the bracket and front jacket panel.
9. Inspect fiberglass rope located on the swing door. The rope must be evenly distributed around the perimeter of the door groove and cannot bunch or overhang. Repair or replace, if the rope is damaged, or, there is a gap between the rope ends.

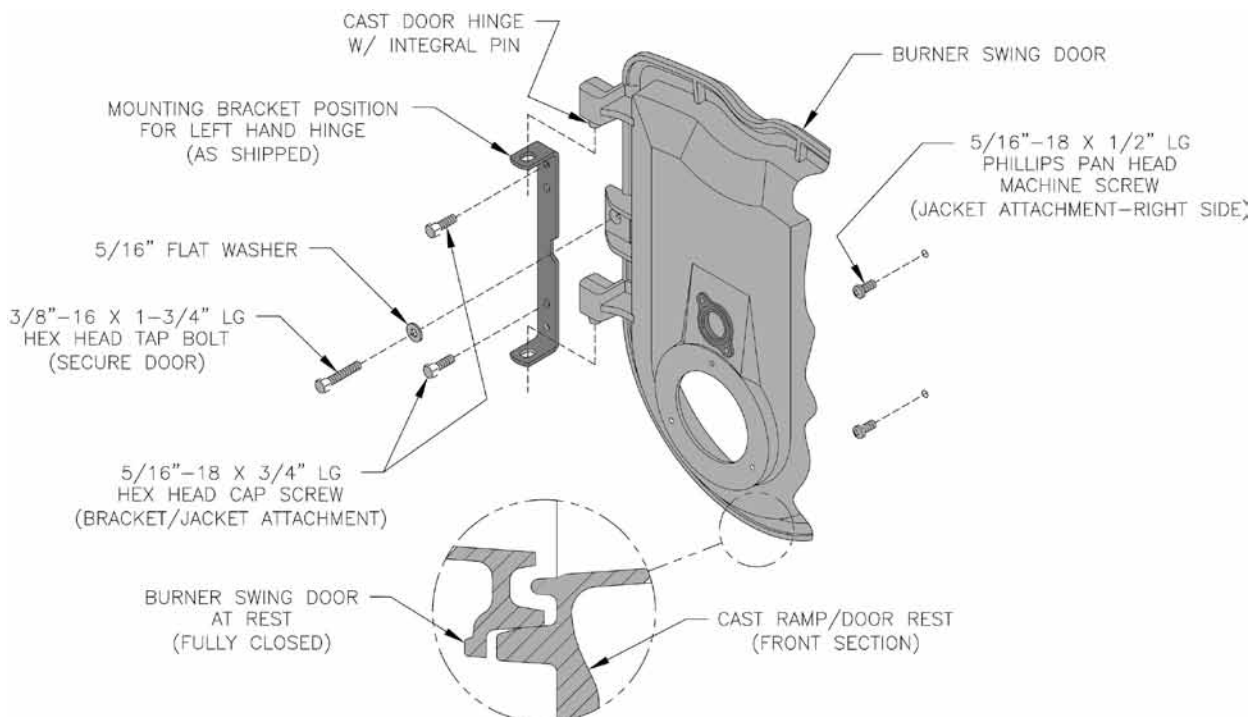

Figure 5A: Partial Front View - Burner Swing Door Mounted to Boiler - Fully Closed and Secured

SECTION II: UNIT-PAK BOILER ASSEMBLY (continued)

10. Inspect burner swing door insulation for damage and proper type.

By design, for all models, cast bars on front section between the combustion chamber, and, between the left and right side 2nd and 3rd pass flueways should make an impression in door insulation to seal the chambers.

By design, door insulation on model MST629 **will have** two by-pass pockets cast into the insulation centered on the bar between the combustion chamber and 3rd pass flueways. By design, door insulation on models MST288, MST396 & MST513 **will not have** any by-pass pockets. If insulation is damaged, or, improper type regarding the pockets, it must be replaced.

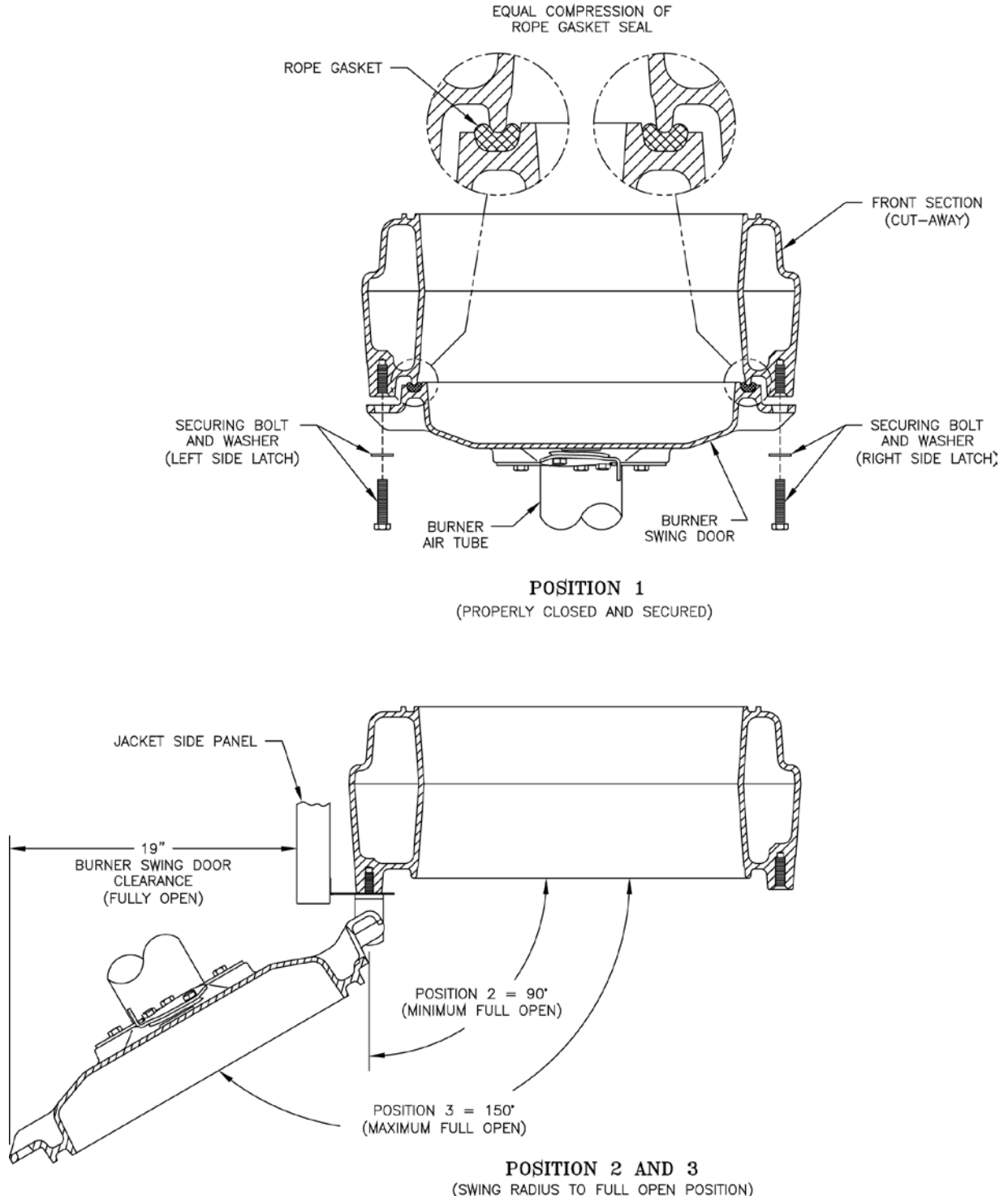

Figure 5B: Top View - Burner Swing Door Mounted to Cast Iron Block Assembly (Jacket Removed for Clarity)

SECTION II: UNIT-PAK BOILER ASSEMBLY (continued)

11. Upon inspection completion, lift door and place integral cast hinge pins into door mounting bracket slotted holes. Do not close and secure door at this time, proceed to installing stainless steel flueway baffles.
12. Locate/remove four #8 x 1/2" shoulder sheet metal screws from Hardware Bag, then, install them into front panel flange holes.

E. FLUEWAY BAFFLE INSTALLATION.

Flueway baffles are enclosed into Part Carton. Baffle requirements differ by boiler model, see Table 2.

TABLE 2: BAFFLE USAGE

Boiler Model	Baffle Usage	
	2 nd Pass	3 rd Pass
MST288	None	
MST396	(2) P/N 100042-01	None
MST513		
MST629		

NOTE: Read caution statement **before** proceeding.

CAUTION

These baffles will generate higher efficiencies and lower stack temperatures. Under certain conditions, a lower gross stack temperature entering the chimney has the potential to be cooled below the dew point and create condensate on interior surfaces. Flue gas condensate is corrosive, which requires special consideration and must be addressed immediately.

DO NOT install baffles until you have read Section V, "Venting" completely.

1. To install flueway baffles, provided in miscellaneous part cartons, as follows, refer to Figure 6 and Table 2:

- Models MST396, MST513 and MST629 - To install flueway baffle in 2nd pass flueway on left side of boiler, hold baffle with word "Left" readable at the top. Slide baffle in flueway until position tab touches fins on right side of 2nd pass flueway. To install flueway baffle in 2nd pass

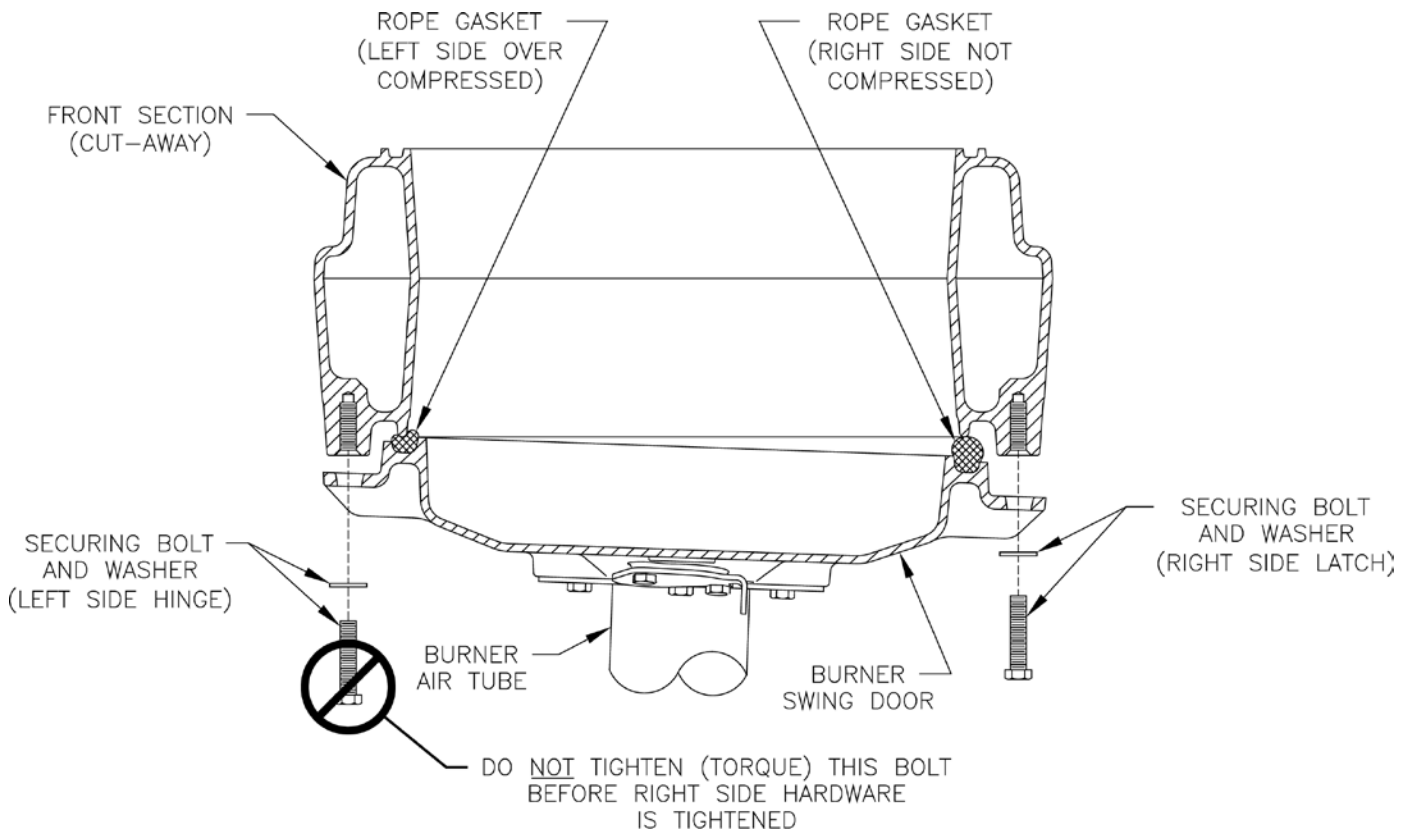

Figure 5C: Top View - Burner Swing Door Fully Closed but Not Properly Secured or Sealed

SECTION II: UNIT-PAK BOILER ASSEMBLY (continued)

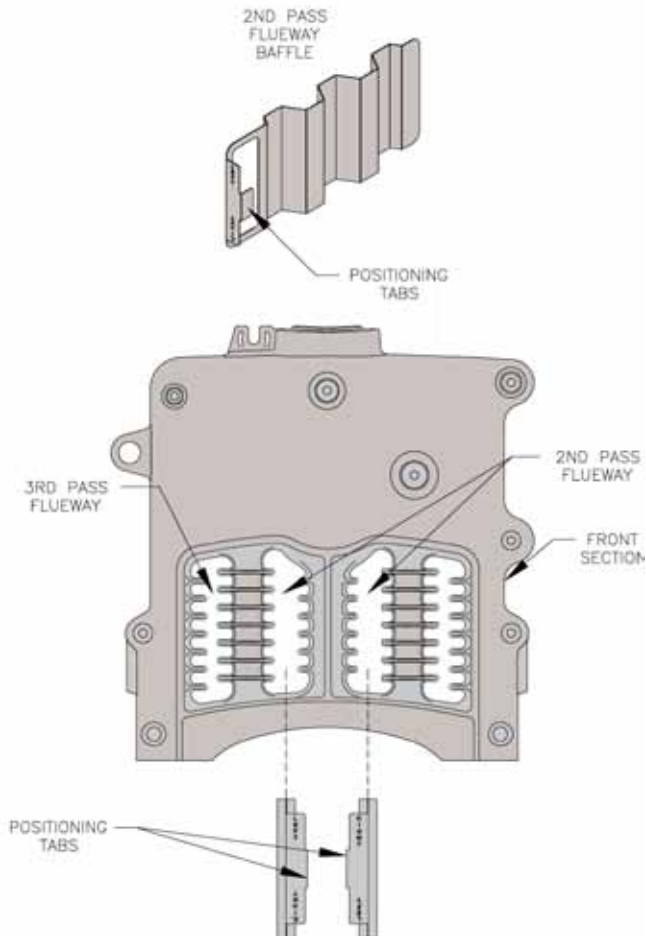

Figure 6: Flueway Baffle Positioning/Orientation in Flueways

flueway on right side of boiler, hold baffle with word "Right" readable at the top. Slide baffle in flueway until position tab touches fins on left side of 2nd pass flueway.

F. CLOSING / SECURING BURNER SWING DOOR.

1. To close and secure Burner Swing Door:
 - a. From fully open position, rotate the door to the closed position.
 - b. Lift door upward into the build-in cast ramp/door rest (protruding from the bottom of the front section casting – see Figure 5A).
 - c. Use one hand to apply pressure directly to the door to hold it in closed position while re-installing earlier removed door-latching hardware (3/8"-16 x 1-3/4" tap bolt and 5/16" washer). Prior to re-installation, apply a drop of supplied Anti-seize (pouch provided in Part Carton) to both tap bolts for rust protection and to facilitate easy removal, if burner door is to be open for inspection and service. **ALWAYS INSTALL RIGHT SIDE LATCHING HARDWARE FIRST,**

THEN INSTALL EARLIER REMOVED LEFT SIDE HINGE HARDWARE (3/8"-16 X 1-3/4" TAP BOLT AND 5/16" WASHER) SECOND. Apply additional pressure while hand tightening the hardware as far as possible and then release the pressure.

NOTICE

When securing burner swing door make sure door is drawn-in equally on both sides.

- d. Use a hand or socket wrench to tighten door hardware. **ALWAYS START WITH RIGHT SIDE TAP BOLT FIRST.** Use an alternating tightening method from right side tap bolt to left side tap bolt to tighten door equally, until sealed, without applying excessive torque. **NEVER TIGHTEN LEFT SIDE TAP BOLT FIRST, OR, EITHER PIECE OF HARDWARE 100% WITHOUT USING THE ALTERNATING METHOD DESCRIBED ABOVE.** See Figure 5B.
- e. Failure to follow the prescribed procedure could cause thread damage to casting and /or leak at the door seal. **IF LEFT SIDE TAP BOLT IS TIGHTENED BEFORE RIGHT SIDE TAP BOLT, RIGHT SIDE OF THE DOOR CAN NOT BE DRAWN-IN TO PROVIDE AN AIR-TIGHT SEAL,** as shown in Figure 5C. Applying excessive torque will only cause thread damage.

G. JACKET REAR PANEL INSTALLATION.

1. Locate jacket rear panel (has factory attached 3" fiberglass insulation) inside Jacket Carton. See also "Repair Parts" Section, "Jacket Assembly" illustration for part identification.
2. Locate and remove from Hardware Bag rear panel mounting hardware – (2 pcs) 5/16"-18 x 3" lg. tap studs, (2 pcs) 5/16"-18 plated acorn nuts, (2 pcs) 5/8" x 2-9/32" round spacers and (2 pcs) 5/16"-18 x 1/2" Phillips pan head machine screws.
3. Locate rear panel two lower attachment bosses on rear section. See Figure 7 "Purpose of Tappings & Bosses".
4. Thread both 5/16"-18 x 3" lg. tap studs, with short threaded end, into lower attachment bosses on rear section.
5. Install both 5/8" x 2-9/32" round spacers over tap studs.
6. Place rear jacket panel over rear section, so both tap studs clear thru lower panel holes, rear section cleanout openings clear thru matching panel cutouts and brass sample port plug clears panel matching hole.

SECTION II: UNIT-PAK BOILER ASSEMBLY (continued)

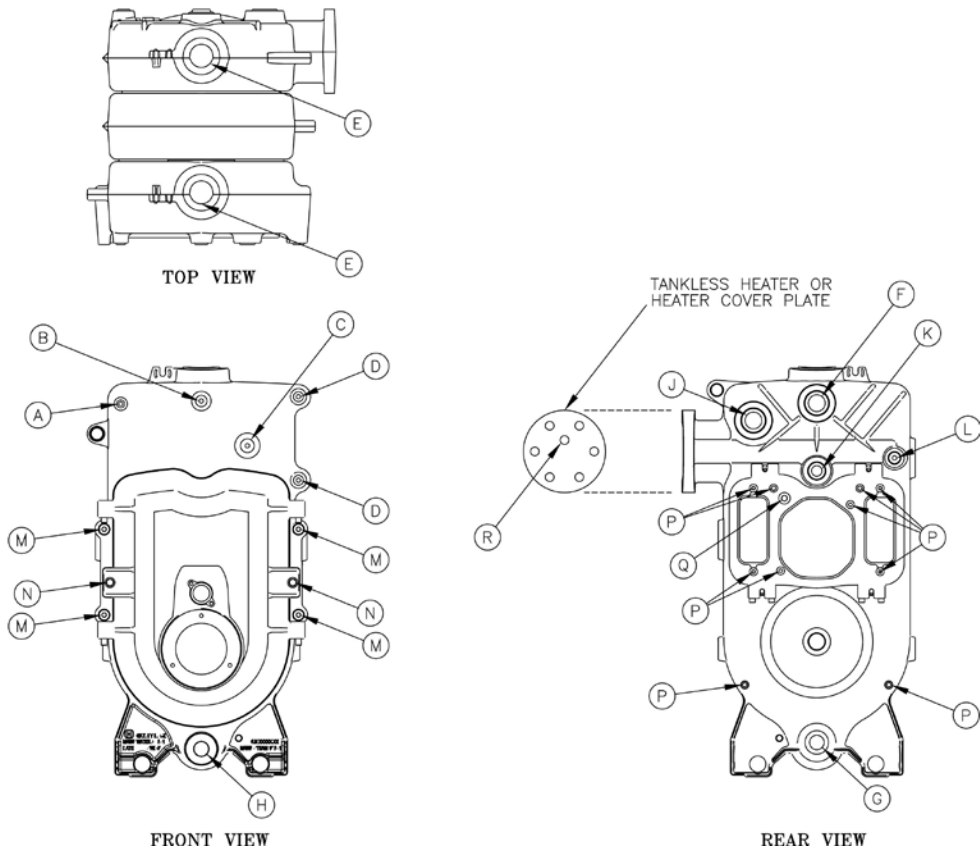

Figure 7: Purpose of Tappings and Bosses

TABLE 3: PURPOSE OF TAPPINGS & BOSSES

Tapping Location	Size, NPT	Boss Location	Thread Size UNC	Steam Boiler	
				Less Heater	With Heater
A	1/4" - 18			Pressure Gauge	
B	1/4" - 18			Pressure Limit	
C	3/4" - 14			Probe LWCO - Std.	Plugged (Float LWCO)
D	1/2" - 14			Water Gauge Glass (Probe LWCO) Water Gauge Glass, Pressure Control & LWCO (Float LWCO)	
E	2" - 11 1/2"			Supply (Front & Rear Tappings)	
F	3/4" - 14			Safety Valve	
G	1 1/2" - 11 1/2"			Condensate Return	
H	1 1/4" - 11 1/2"			Optional Front Return	
J	1 1/2" - 11 1/2"			Surface Blowoff (Plugged)	
K	1" - 11 1/2"			Indirect Water Heater Supply	
L	1/2" - 14			Indirect Water Heater Limit	
		M (4 pcs)	5/16" - 18	Jacket Front Panel, Burner Swing Door Mounting Bracket	
		N (2 pcs)	3/8" - 16	Burner Swing Door	
		P (10 pcs)	5/16" - 18	Jacket Rear Panel, Smoke Box Collar, Cleanout Covers	
Q	1/4" - 18			Smokebox Pressure Tapping	
R	1/2"-14			L4006 Operating Control	Plugged

SECTION II: UNIT-PAK BOILER ASSEMBLY (continued)

7. Secure panel bottom to studs with acorn nuts hand tight.
8. Align upper panel attachment holes with smokebox upper attachment bosses and install 5/16"-18 x 1/2" Phillips pan head machine screws hand tight.
9. Securely tighten rear jacket panel mounting hardware.
10. Locate/remove four #8 x 1/2" shoulder sheet metal screws from Hardware Bag, then, install them into rear panel flange holes.

H. FLUE CLEANOUT COVERS AND SMOKEBOX COLLAR INSTALLATION.

1. Remove two cast iron Cleanout Covers, cast iron Smokebox Collar and the tube of hi-temperature silicon adhesive sealant from Part Carton. See also "Repair Parts" Section, "Bare Boiler Assembly" illustration for part identification.
2. Check the rope gasket factory attached to the covers. Repair or replace, if the rope is damaged, or, there is a gap between the rope ends.
3. Locate/remove four 5/16"-18 – 7/8" hex head cap screws from Hardware Bag.
4. Apply a drop of supplied Anti-seize (pouch provided in Part Carton) to each of four (4) 5/16"-18 x 7/8" hex head cap screws for rust protection and to facilitate easy removal for future service.
5. Position left Cleanout Cover over rear section cleanout opening, align section boss holes with Cleanout Cover holes, install both 5/16"-18 – 7/8" hex head cap screws hand tight, then, alternately tighten them with open end or socket wrench.
6. Repeat above steps with right Cleanout Cover.
7. Apply the adhesive sealant to the underside of the collar, all around, at the inside corner of the collar outer ring. Insure adhesive bead is complete all around and without gaps.
8. Place the collar over smokebox tongue and align collar integral mounting ear slots with smokebox bosses.
9. Thread-in both 5/16"-18 – 7/8" hex head cap screws hand tight, then, alternately tighten them with open end or socket wrench.

I. INSULATION WRAPPER AND BURNER POWER OUTLET RECEPTACLE WITH HARNESS INSTALLATION.

1. Insulation Wrapper is vacuum packed/sealed in plastic bag at the factory.
2. Carefully cut the plastic bag and remove Insulation Wrapper. The wrapper will expand upon removal.

3. Unfold Insulation Wrapper, position it over section assembly centered left to right and align two wrapper upper holes with 2" NPT pipe tappings in front and rear section top.
4. Insure wrapper fits snugly around rear section tankless heater collar/ mounting flange (if boiler is equipped with tankless heater) and trim the insulation at tankless heater cutout. Do not trim off insulation on boilers having non-heater rear section.
5. Tack Insulation Wrapper bottom ends under section assembly, between front and rear section legs.
6. Locate and remove Burner Power Outlet Receptacle with factory attached Burner Harness from Control Carton.
7. Feed Molex end of Burner Harness thru front jacket panel right side outlet receptacle cutout. Insure that the receptacle middle prong opening is facing down. Snap the receptacle into front jacket panel. Temporarily, stuff Molex end of Burner Harness between front panel insulation and insulation wrapper near boiler top.

J. SIDE AND TOP JACKET PANEL INSTALLATION.

1. Pick up Left Side Jacket Panel from Jacket Carton. See also "Repair Parts" Section, "Jacket Assembly" illustration for part identification.
2. Place Left Side Jacket Panel over four #8 x 1/2" shoulder sheet metal screws, earlier installed at Front and Rear Jacket Panel side flanges, so teardrop cutouts in the side panel inside flanges engage all four screws simultaneously.
3. Slide the panel downwards to lock all screws securely.
4. Pick up Right Side Jacket Panel from Jacket Carton. See also "Repair Parts" Section, "Jacket Assembly" illustration for part identification.
5. Pick up Molex end of Burner Harness stuffed between front panel insulation and insulation wrapper and feed it thru Right Side Jacket Panel front cutout, letting the harness connector to hang over the cutout edge temporarily.
6. Place Right Side Jacket Panel, clearing rear section tankless heater collar/ mounting flange, over four #8 x 1/2" shoulder sheet metal screws, previously installed at Front and Rear Jacket Panel side flanges, so teardrop cutouts in the side panel inside flanges engage all four screws simultaneously.
7. Slide the panel downwards to lock all screws securely.
8. Pick up Top Jacket Panel from Jacket Carton.

SECTION II: UNIT-PAK BOILER ASSEMBLY (continued)

- Place the panel between side panels upper inside flanges and slide it forward, until top panel front flange U-bend locks over front panel top flange, and, top panel rear flange is positioned over rear jacket panel.
- Locate/remove two #8 x 1/2" sheet metal screws from Hardware Bag.
- Install both screws into top panel rear flange to secure the top panel to rear jacket panel.

K. EXTERNAL ELECTRICAL ENCLOSURE MOUNTING.

- Remove two #8 x 1/2" shoulder sheet metal screws and one #8 x 1/2" sheet metal screw from Hardware Bag.
- Install both #8 x 1/2" shoulder sheet metal screws into Right Side Jacket Panel, at two upper corners of the panel front cutout.
- Locate and remove External Electrical Enclosure assembly from Control Carton.
- Remove the enclosure cover and set aside.
- Pick Molex connector end of Burner Harness and feed it inside the enclosure, thru bushed hole at enclosure lower left corner, next to transformer/relay.
- Place the enclosure over installed shoulder sheet metal screws, so teardrop cutouts in the enclosure base engage both screws simultaneously, then, slide the enclosure downwards to lock it in place.
- Install #8 x 1/2" sheet metal screw thru enclosure base lower hole, located to the right of transformer/relay, into right side panel to secure the enclosure.
- Plug-in burner harness Molex connector into dedicated burner harness receptacle inside the enclosure (lower left off transformer/relay). See "Control Plug-In Diagram" label attached to inside of the enclosure cover for details.
- Do not install the enclosure cover yet; proceed to control installation.

L. TRIM AND CONTROLS INSTALLATION.

Pressure Limit Installation.

- Locate and remove L404F Pressure Limit with factory attached harness from Control Carton.
- Locate and remove 1/4" NPT x 1-7/8" x 4 x 90° syphon enclosed in Part Carton.
- Review and locate pressure limit tapping on front section. See Table 3 "Purpose of Tappings & Bosses" and Figure 7.
- Thread 1-7/8" lg. syphon-threaded short end into the bottom of Pressure Limit with factory attached

harness. Do not tighten the syphon by holding the limit case; apply a wrench to the brass hex below the case.

- Thread 1/4" NPT x 4" lg. syphon-threaded long end into pressure limit tapping on front section. See Figure 8 "Pressure Limit Installation.
- L404F pressure limit does not require leveling. The pressure limit final orientation must be parallel to boiler front, having the harness on the right side.
- Pick-up the pressure limit harness Molex end and feed it into the enclosure, thru top flange rear left 7/8" hole; then, snap-in harness BX connector into the hole, and, plug Molex connector into dedicated pressure limit receptacle inside the enclosure (upper left off transformer/relay). See "Control Plug-In Diagram" label attached to inside of the enclosure cover for details.

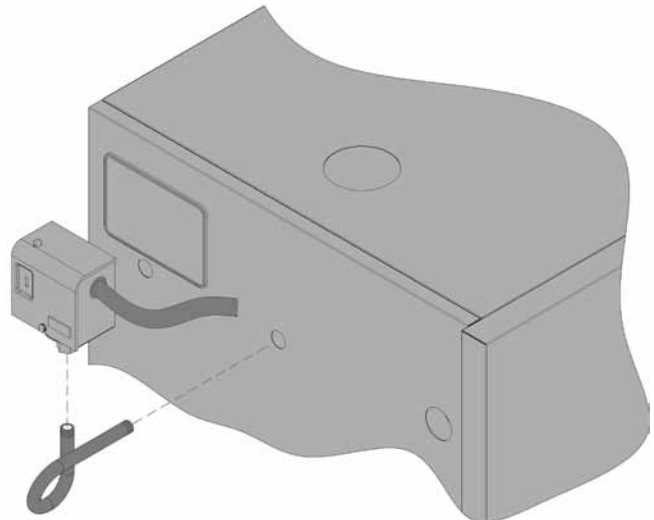

Figure 8: Pressure Limit Installation

M. PROBE LWCO (HYDROLEVEL CG450, OR, MCDONNELL-MILLER PS801-120) INSTALLATION.

- Remove either Hydrolevel CG450 LWCO with factory attached harness and Hydrolevel probe #EL1214, or, McDonnell-Miller PS801-120 with factory attached harness and #153875 probe from Control Carton.
- Install the probe into the appropriate front section tapping. See Figure 7 "Purpose of Tappings & Bosses".
- Slip LWCO with factory attached harness over the probe and clamp in place. Note that CG450 LWCO will be positioned right side up, with diagnostic LED(s) on the top flange, while PS801 LWCO will be positioned upside down, with diagnostic LED(s) on the bottom flange. Connect the wire(s) between the probe and control per manufacturer's instructions.

SECTION II: UNIT-PAK BOILER ASSEMBLY (continued)

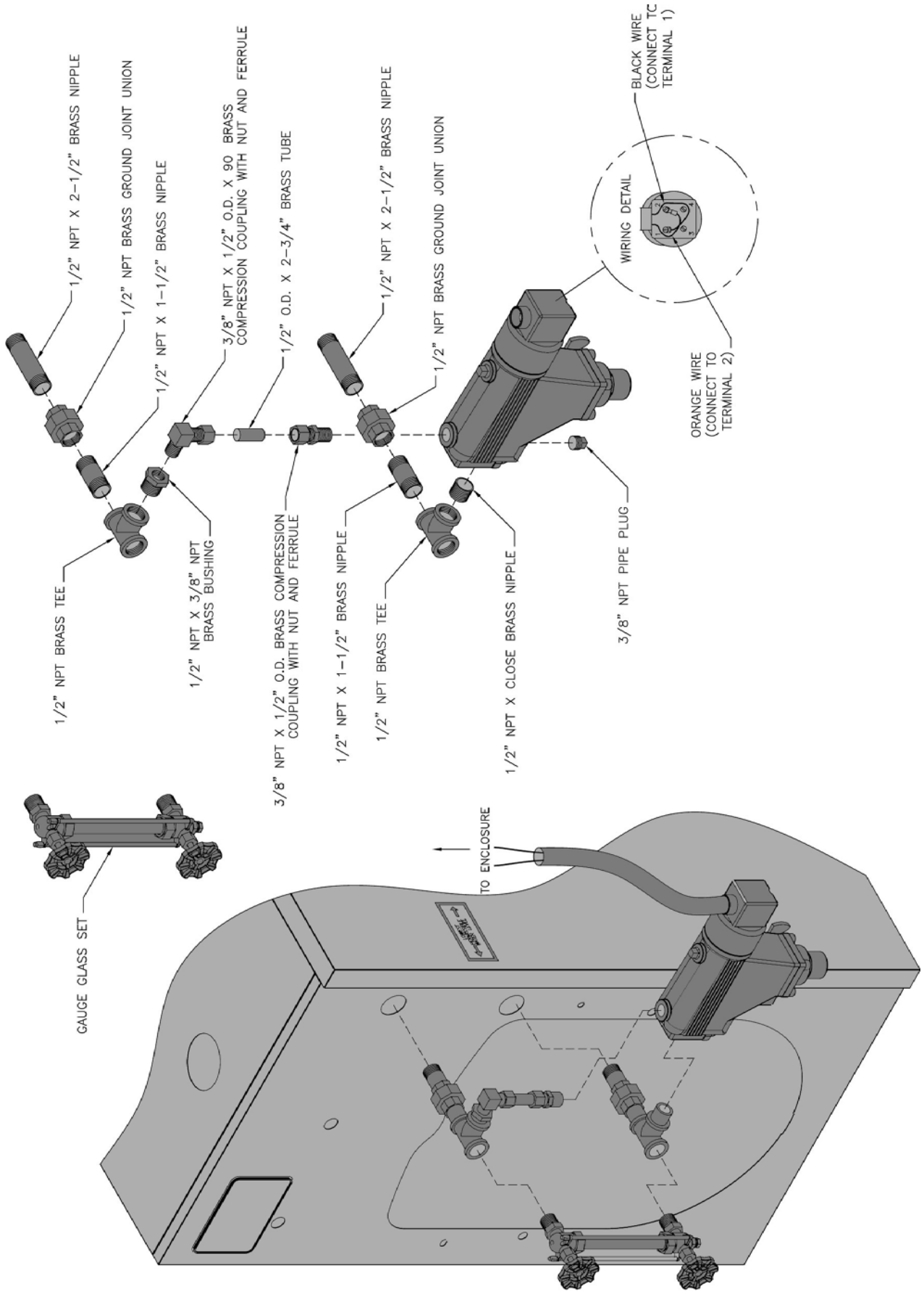

Figure 9: Float-Type LWCO and Pressure Limit Installation

SECTION II: UNIT-PAK BOILER ASSEMBLY (continued)

- Pick-up the LWCO harness Molex end and feed it into the enclosure, thru external electrical enclosure top flange front left 7/8" hole; then, snap-in harness BX connector into the hole, and, plug-in Molex connector into dedicated LWCO receptacle inside the enclosure (middle left off transformer/relay). See "Control Plug-In Diagram" label attached to inside of the enclosure cover for details.

N. PRESSURE GAUGE AND GAUGE GLASS INSTALLATION.

- Remove the 6" water gauge glass set from Part Carton.
- Install the gauge glass using the two 1/2" NPT tappings to the right of the probe LWCO. See Figure 7 "Purpose of Tappings & Bosses".
- Thread the pressure gauge into 1/4" NPT tapping of the front section. See Figure 7 "Purpose of Tappings & Bosses". Tighten with wrench applied to the square shank of the gauge.

CAUTION

Do not apply pressure to gauge case, as this may result in inaccurate readings.

O. FLOAT LWCO (MCDONNELL-MILLER #67), AND GAUGE GLASS INSTALLATION.

- Pre-assemble float-type LWCO per Figure 9 "Float-Type LWCO and Gauge Glass Installation".
- Install two 1/2" NPT x 2 1/2" long Sch 40 brass nipples, supplied loose inside Control Carton (disregard two 1/2" NPT x 1 1/2" long brass nipples provided with #67 LWCO package) and 1/2" NPT brass unions into upper and lower front section tappings. See Table 3 "Purpose of Tappings & Bosses" and Figure 7.
- Install water gauge glass on low water cut-off assembly tee fittings.
- Do not remove 1/4" NPT plug factory installed on top of #67 LWCO.
- Insure that 3/8" NPT plug (provided within #67 LWCO package) is installed at bottom of #67 LWCO.
- Remove #67 LWCO J-box cover.
- Screw LWCO to External Wiring Enclosure wiring harness (end with fork and female disconnect terminals) connector into low water cut-off J-box top fitting, and attach wires to the terminals per LWCO wiring detail shown in Figure 9 "Float-Type LWCO and Gauge Glass Installation".
- Re-install #67 LWCO J-box cover.
- Pick-up the LWCO harness Molex end and feed it into the enclosure, thru external electrical enclosure

top flange front left 7/8" hole; then, snap-in harness BX connector into the hole, and, plug-in Molex connector into dedicated LWCO receptacle inside the enclosure (middle left off transformer/relay). See "Control Plug-In Diagram" label attached to inside of the enclosure cover for details.

- Pick-up the pressure limit harness Molex end and feed it into the enclosure, thru External Electrical Enclosure top flange rear left 7/8" hole; then, snap-in harness BX connector into the hole, and, plug-in Molex connector into dedicated pressure limit receptacle inside the enclosure (upper left off transformer/relay). See "Control Plug-In Diagram" label attached to inside of the enclosure cover for details.

P. AQUASTAT CONTROLLER INSTALLATION (BOILERS WITH TANKLESS HEATER ONLY).

- On boilers with tankless heater, install the L4006A aquastat controller well (found in Part Carton) into 1/2" NPT tapping in tankless heater plate.
- Remove the L4006A aquastat controller with factory attached harness from Control Carton.
- Slip the bulb of the aquastat controller into the well and secure the controller in place with the set screw.

WARNING

Aquastat bulb must be fully inserted into the well.

- Feed the L4006A aquastat controller harness end thru external electrical enclosure top flange middle right bushed hole. See "Control Plug-In Diagram" label attached to inside of the enclosure cover for details.
- See Figures 19 thru 20 (whichever applicable) for tankless heater aquastat connection details.
- Using needle nose pliers form hook on harness each stripped end and wrap hooks around screws under terminals "R" and "G" of the R8285C Transformer-Relay; then, tighten screws securely.

Q. SAFETY VALVE AND DRAIN VALVE INSTALLATION.

- Remove safety valve and related piping (3/4" NPT x 3" lg. black nipple, 3/4" NPT x 8" lg. black nipple, 3/4" NPT 90° black elbow and 3/4" NPT black coupling) from Part Carton.
- Thread 3/4" NPT x 3" lg. black nipple into rear section safety valve tapping, install 3/4" NPT 90° black elbow facing upward, then, thread 3/4" NPT x 8" lg. black nipple into the elbow, and, install 3/4" NPT black coupling onto nipple end.

SECTION II: UNIT-PAK BOILER ASSEMBLY (continued)

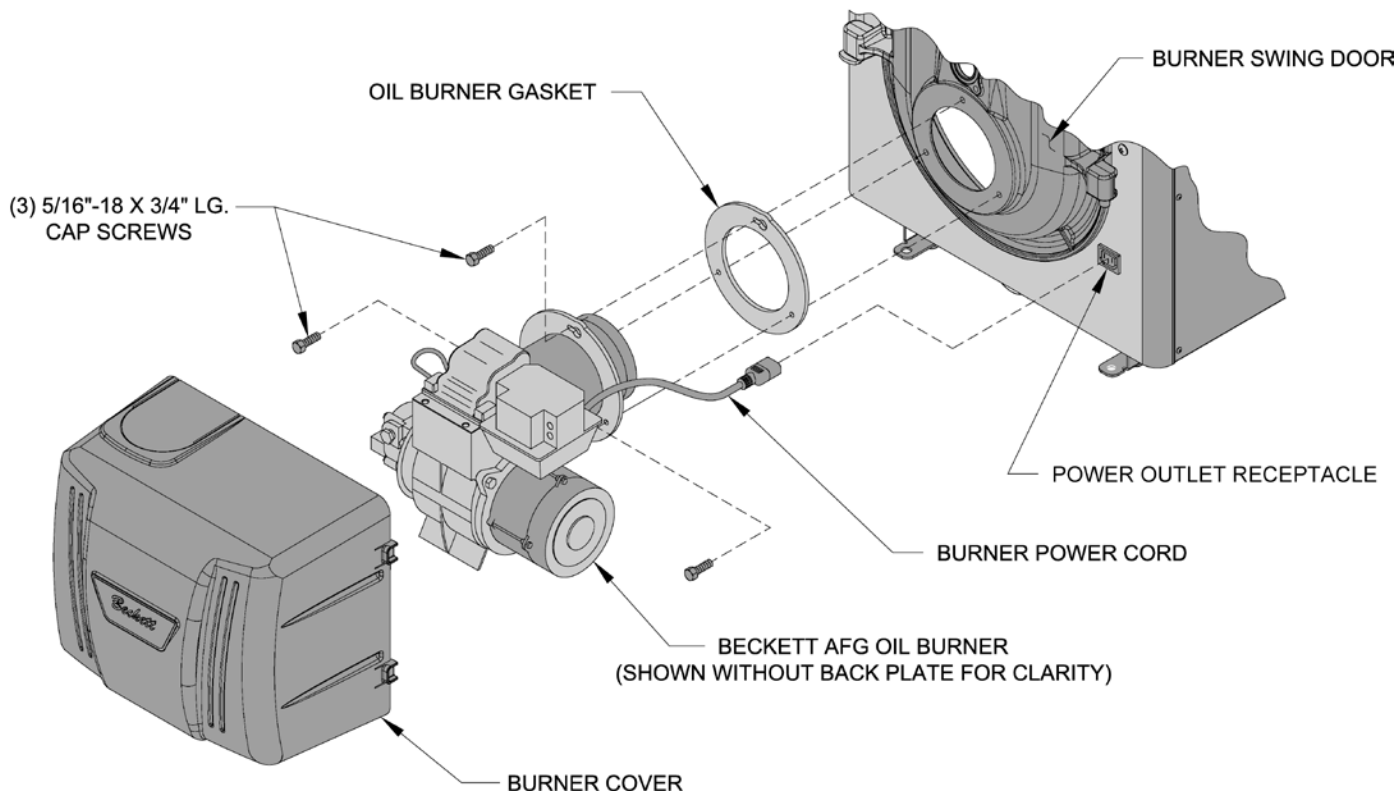

Figure 10: Oil Burner Installation (Beckett Burner Shown)

3. Thread safety valve into the $\frac{3}{4}$ " NPT black coupling. Pipe the safety valve discharge as shown in Figure 12 "Recommended Boiler Piping For Gravity Return Steam Boiler" shown in Section III of this manual. Installation of the safety valve must be consistent with ANSI/ASME Boiler and Pressure Vessel Code, Section IV.

WARNING

Safety valve discharge piping must be piped near floor to eliminate potential of severe burns. Do not pipe in any area where freezing could occur. Do not install any shut-off valves, plugs or caps.

4. Remove 1-1/2" NPT x 5" lg. black nipple, 1-1/2" x 1-1/2" x $\frac{3}{4}$ " NPT black tee and drain valve from Part Carton.

NOTICE

Lower rear section Tapping "H" is used for standard condensate return on steam boilers.

5. Thread 1-1/2" NPT x 5" lg. black nipple into lower rear section tapping, then, install 1-1/2" x 1-1/2" x $\frac{3}{4}$ " NPT black tee onto nipple end. Black tee side outlet may be oriented to either left, or, right side.

6. Install the drain valve into black tee $\frac{3}{4}$ " NPT side outlet.

R. OIL BURNER INSTALLATION.

1. Install oil burner, refer to Figure 10.
 - a. Open burner carton and remove contents.
 - b. Check oil nozzle in burner for size, angle and type, inspect electrode settings, check head setting, check air band and air shutter settings, refer to Tables 7 thru 7B at rear of this manual.
 - c. Place oil burner gasket on burner and align holes.

CAUTION

Do not install burner without gasket.

- d. Remove three (3) 5/16-18 x 3/4 lg. cap screw from burner swing door used for mounting burner.
- e. Thread (1) 5/16-18 x 3/4 lg. cap screw, approximately three (3) full turns, into tapping located at 12:00 o'clock on burner swing door.
- f. Insert oil burner into the opening of burner swing door. Align and engage keyhole slot in burner flange over head of protruding cap screw installed in previous Step. Rotate burner to the right to lock flange behind head of cap screw.

SECTION II: UNIT-PAK BOILER ASSEMBLY (continued)

- g. Align holes and install two (2) remaining cap screws. Level burner and fully tighten all three (3) screws.
 - h. Plug burner power cord into power outlet receptacle located in lower right corner of front panel.
2. Install Riello oil burner, refer to Figure 10.
- a. Loosen Burner cover Holding Screws and remove Burner Cover. Check oil nozzle in burner for size, angle and type, inspect electrode settings and check insertion depth and turbulator setting. Refer to Table 7A "Riello burner Specifications" at rear of this manual.
 - i. Installation/Removal of Drawer Assembly. Refer to Figure 11A.

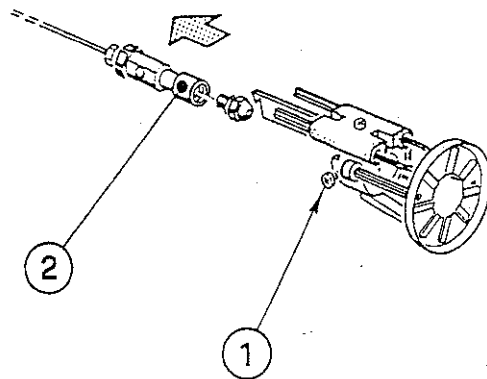

Figure 11B: Nozzle Replacement

- b. Remove existing nozzle from nozzle adapter.
 - c. Insert the proper NOZZLE into NOZZLE ADAPTER and tighten securely (Do not over tighten).
 - d. Replace adapter, with nozzle installed, into drawer assembly and secure with screw (1).
- iii. **Inspect/Measure Burner Electrodes.** Refer to Figure 11C.
- iv. **Re-install Drawer Assembly into Combustion Head.** Refer to Figure 11B.
- v. **Check Insertion Depth.** Verify the distance between the tip of the end cone to face of the burner mounting flange is as specified in Table 7A "Riello Burner Specifications" at rear of this manual.

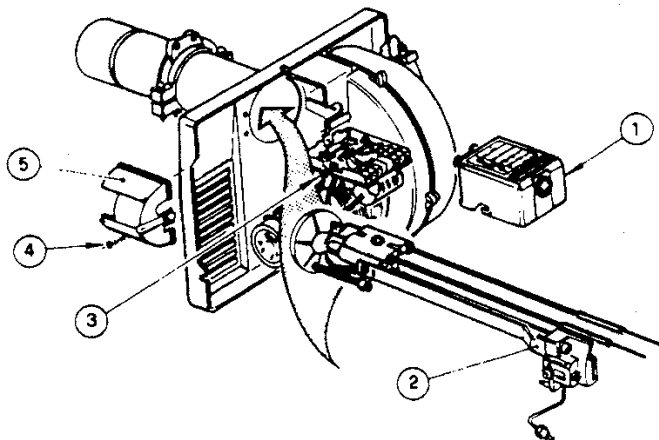

Figure 11A: Installation/Removal of Drawer Assembly

- a. Removal:
 - Disconnect oil delivery tube nut from pump.
 - Loosen SCREW (3), and then unplug PRIMARY CONTROL (1) by carefully pulling it back and then up.
 - Remove the AIR TUBE COVER PLATE (5) by loosening the retaining SCREW (4) (Two SCREWS - Model F5).
 - Loosen SCREW (2), and then slide the complete drawer assembly out of the combustion head as shown.
 - b. Installation:
 - To insert drawer assembly, reverse the procedure in Step ii, a thru d.
- ii. **Nozzle Replacement** (if required). Refer to Figure 11B.
- a. Remove the NOZZLE ADAPTER (2) from the DRAWER ASSEMBLY by loosening the SCREW (1).

IMPORTANT: THESE DIMENSIONS MUST BE OBSERVED AND VERIFIED.

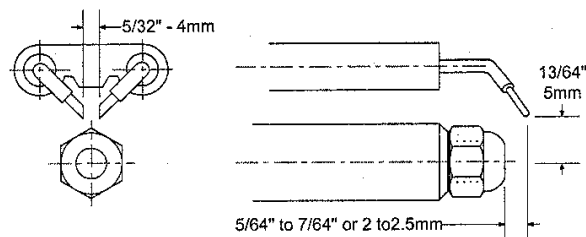

Figure 11C: Electrode Setting

- vi. **Verify Turbulator Setting**, Refer to Figure 11D.
 - a. Confirm the turbulator setting is as specified in Table 7A "Riello Burner Specifications" of this supplement.
 - b. If adjustment required, loosen RETAINING NUT (1), then, turn SCREW (2) until the INDEX MARKER (3) is aligned with the correct index number shown in Table 7A "Riello Burner Specifications" at rear of this manual.

SECTION II: UNIT-PAK BOILER ASSEMBLY (continued)

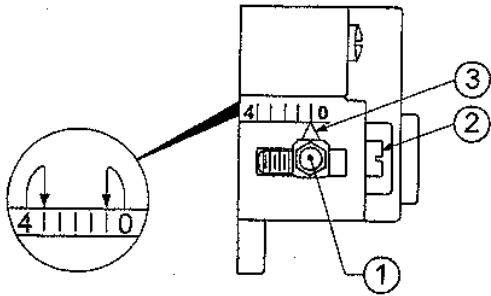

Figure 11D: Turbulator Setting

- c. Retighten the RETAINING NUT (1) upon adjustment completion.

MODEL F5 NOTE: Zero and Four are scale indicators only. From left to right the first line is four (4) and the last line is zero (0).

vii. **Pump Connections and Port Identification**, Refer to Figure 11E.

This burner is shipped with the oil pump set to operate on a **single** line system. To operate on a **two-line** system the bypass plug must be installed.

WARNING: Do not operate a **single** line system with the by-pass plug installed. Operating a **single** line system with the by-pass plug installed will result in damage to the pump shaft seal.

NOTE: Pump pressure was factory pre-set but must be checked at time of burner start-up. A pressure gauge is attached to the **PRESSURE/ BLEEDER PORT** (7) for pressure readings.

Two **PIPE CONNECTORS** (4) are supplied with the burner for connection to either a single or two-line system. Also supplied are two **ADAPTORS** (3), two female 1/4" NPT to adapt oil lines to burner pipe connectors. All pump port threads are **British Parallel Thread** design. Direct connection of NPT threads to the pump **will damage** the pump body.

Riello manometers and vacuum gauges **do not** require any adapters, and can be safely connected to the pump ports. An NPT x metric adapter **must** be used when connecting other gauge models.

viii. **Replace Burner Cover** and Tighten Burner Cover Screws.

- c. Place oil burner gasket on burner and align holes.
- d. Remove three (3) 5/16-18 x 3/4 lg. cap screw from burner swing door used for mounting burner.
- e. Thread (1) 5/16-18 x 3/4 lg. cap screw, approximately three (3) full turns, into tapping located at 12:00 o'clock on burner swing door.
- f. Insert oil burner into the opening of burner swing door. Align and engage keyhole slot in burner flange over head of protruding cap screw installed in previous Step. Rotate burner to the right to lock flange behind head of cap screw.
- g. Align holes and install two (2) remaining cap screws. Level burner and fully tighten all three (3) screws.

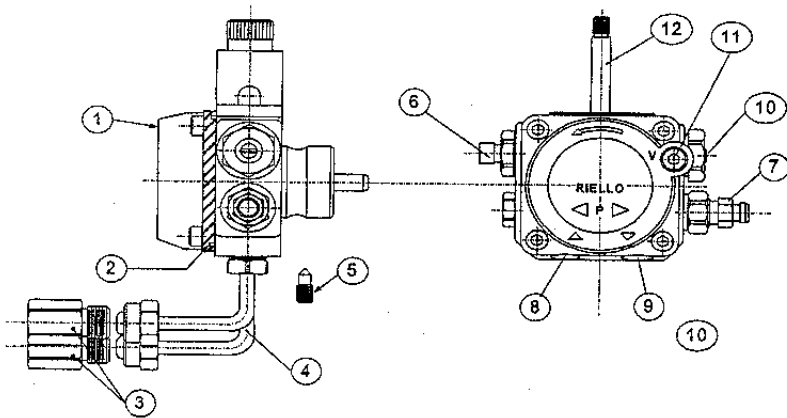

PUMP LEGEND

1. PUMP COVER
2. PUMP COVER O-RING
3. BSPP TO NPT ADAPTORS
4. SUPPLY AND RETURN OIL LINES
5. RETURN PORT BY PASS SCREW
6. NOZZLE PORT - PUMP OULET TO NOZZLE
7. PUMP PRESSURE PORT AND BLEEDER PORT
8. PUMP SUPPLY PORT
9. PUMP RETURN PORT
10. PUMP PRESSURE REGULATING SCREW
11. VACUUM PORT
12. PUMP VALVE STEM

Figure 11E: Pump Connections and Port Identification

SECTION III: STEAM BOILER PIPING & TRIM

WARNING

Failure to properly pipe boiler may result in improper operation and damage to boiler or structure.

Do not increase steam boiler input above the ratings.

A. EVALUATE THE EXISTING STEAM SYSTEM.

The single most important factor in determining the expected life cycle of a steam boiler, is the amount of fresh water added to the boiler during operation. Fresh water brings minerals and oxygen into the boiler. These contaminants greatly accelerate corrosion of the cast iron boiler sections.

1. Assure that all system radiators, piping and vents are absolutely leak tight.
 - a. When a steam boiler is installed in an existing system, ALL air vents should be replaced at the same time. This assures that the new boiler will not be compromised by existing system leaks.
 - b. If the system contains hidden supply or return piping (hidden behind walls, buried in concrete, etc.) pressure test this piping to assure there are no leaks.

2. Repair any leaks in the system.

3. Install accurate water meter on the fresh water supply to the boiler.

- #### B. CONNECT SYSTEM SUPPLY AND RETURN PIPING TO BOILER. See Figure 12 for piping details. Also, consult Residential Hydronic Heating Installation and Design I=B=R Guide.

CAUTION

Maintain minimum ½ inch clearance from hot water piping to combustible materials.

NOTICE

Do not use softened water in steam boilers. Accelerated boiler corrosion will result. Tie in fresh water supply to the boiler upstream of a water softener.

Oxygen contamination of boiler water will cause corrosion of iron and steel boiler components, and can lead to boiler failure. U.S. Boiler Company's Standard Warranty does not cover problems caused by oxygen contamination of boiler water or scale (lime) build-up caused by frequent addition of water.

Before using copper for steam piping, consider the following characteristics of copper piping:

- 1) high coefficient of thermal expansion can induce mechanical stresses and cause expansion/contraction noises if not accounted for in the piping system design and installation,
- 2) high heat transfer rate (heat loss) of uninsulated copper piping must be included in the normal piping and pickup factors used to size the boiler,
- 3) soldering or brazing pastes and fluxes that end up in the system can cause poor heat transfer, surging, an unsteady water line and wet steam if not thoroughly removed during the boil out procedure and,
- 4) galvanic corrosion of the adjoining metal may occur due to dissimilar metals in certain water chemistries if dielectric unions are not used.

SECTION III: STEAM BOILER PIPING & TRIM (continued)

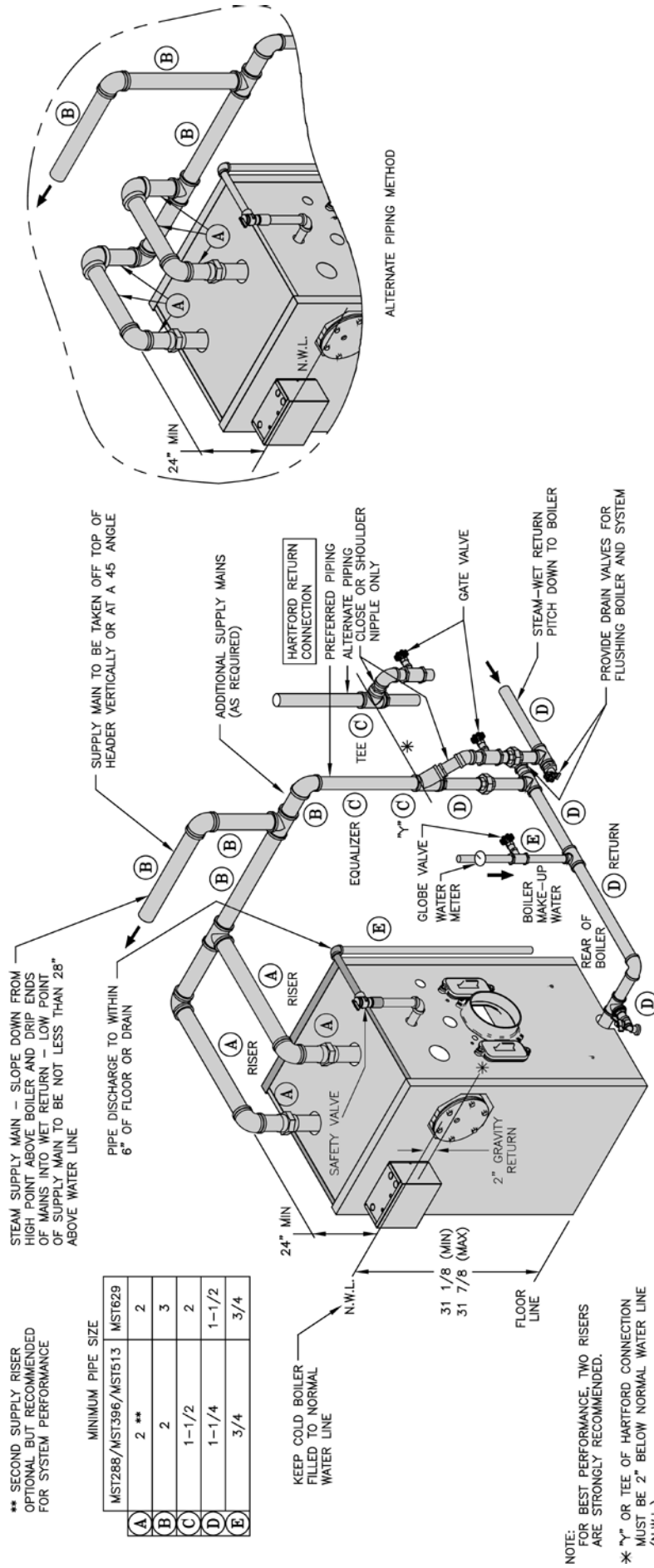

Figure 12: Recommended Boiler Piping for Gravity Return Steam Boiler

SECTION IV: TANKLESS & INDIRECT WATER HEATER PIPING

- A. **CONNECT TANKLESS HEATER PIPING** as shown in Figure 13. See Table 4 for Tankless Heater Rating.

WARNING

Install automatic mixing valve at tankless heater outlet to avoid risk of burns or scalding due to excessively hot water at fixtures. Adjust and maintain the mixing valve in accordance with the manufacturer's instructions. Do not operate tankless heater without mixing valve.

THE FOLLOWING GUIDELINES SHOULD BE FOLLOWED WHEN PIPING THE TANKLESS HEATER:

1. **FLOW REGULATION** — If flow through the heater is greater than its rating, the supply of adequate hot water may not be able to keep up with the demand. For this reason a flow regulator matching the heater rating should be installed in the cold water line to the heater. The flow regulator should preferably be located below the inlet to the heater and a minimum of 3' away from the inlet so that the regulator is not subjected to excess temperatures that may occur during "off" periods when it is possible for heat to be conducted back through the supply line. The flow regulator also limits the flow of supply water regardless of inlet pressure variations in the range of 20 to 125 psi.
2. **TEMPERING OF HOT WATER** — Installation of an automatic mixing valve will lengthen the delivery of the available hot water by mixing some cold water with the hot. This prevents the possibility of scalding hot water at the fixtures. In addition, savings of hot water will be achieved since the user will not waste as much hot water while seeking a water temperature. Higher temperature hot water required by dishwashers and automatic washers is

possible by piping the hot water from the heater prior to entering the mixing valve. The mixing valve should be "trapped" by installing it below the cold water inlet to heater to prevent lime formation in the valve. Refer to Figure 13.

3. **FLUSHING OF HEATER** — All water contains some sediment which settles on the inside of the coil. Consequently, the heater should be periodically back washed. This is accomplished by installing hose bibs as illustrated and allowing water at city pressure to run into hose bib A, through the heater, and out hose bib B until the discharge is clear. The tees in which the hose bibs are located should be the same size as heater connections to minimize pressure drop.
4. **HARD WATER** — A water analysis is necessary to determine the hardness of your potable water. This is applicable to some city water and particularly to well water. An appropriate water softener should be installed based on the analysis and dealer's recommendation. This is not only beneficial to the tankless heater but to piping and fixtures plus the many other benefits derived from soft water.

NOTICE

During summertime operation, the normal water line on a steam boiler can be raised 1", from 28-7/8" to 29-7/8" (see Figure 1) for improved tankless heater performance on steam boilers.

Use street elbow fittings in tankless in and out connections to assure adequate clearance of piping.

CAUTION

Use of hard water with a tankless coil will, over a short period of time, reduce the output of the coil and reduce the useful life of the coil.

SECTION IV: TANKLESS & INDIRECT WATER HEATER PIPING (cont'd)

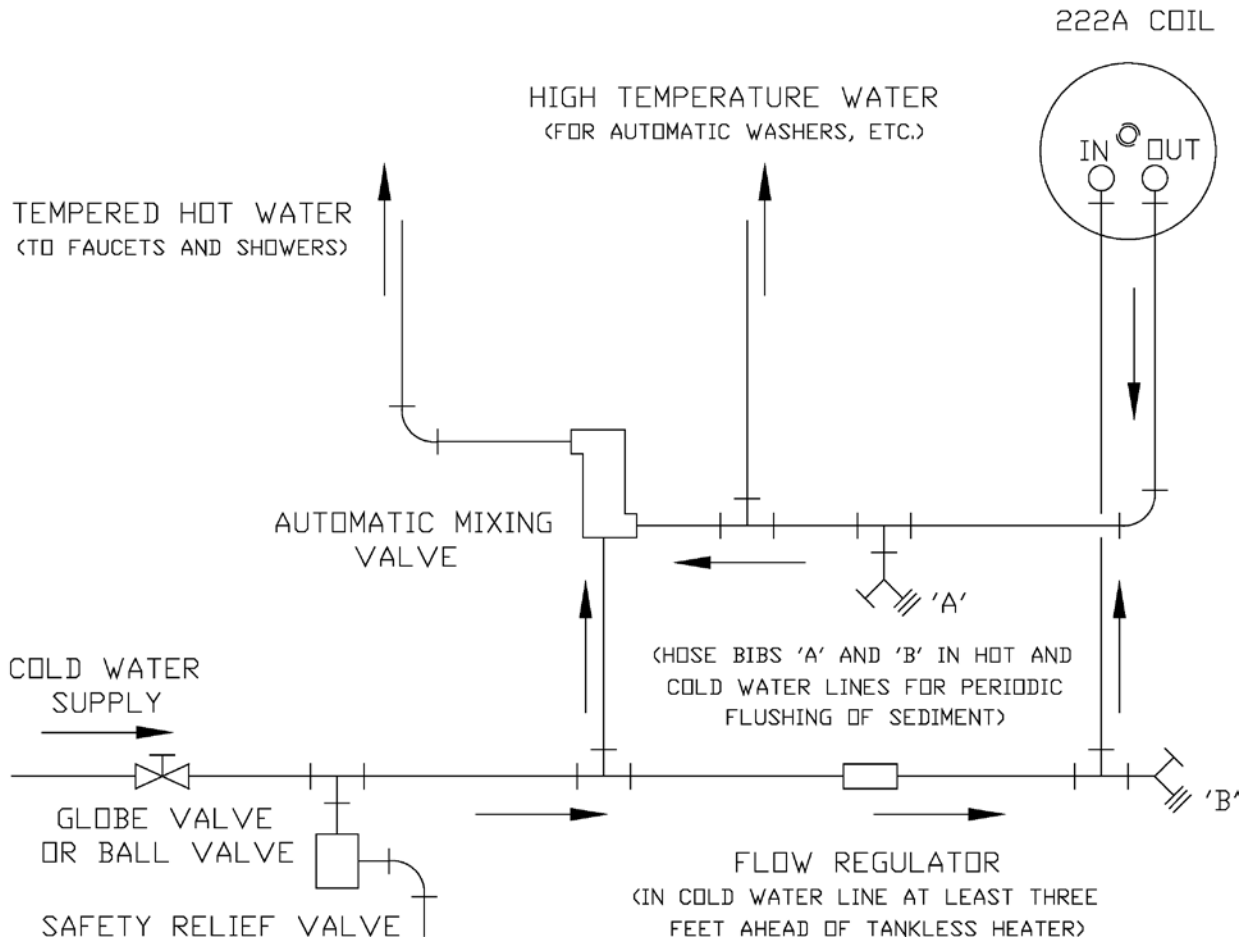

Figure 13: Schematic Tankless Water Heater Piping

TABLE 4: TANKLESS HEATER DATA:

Boiler Model	Heater No.	Heater Rating (GPM)	Pressure Drop thru Heater (PSI)
MST288	222A	3.00	22.0
MST396		3.25	24.3
MST513		3.50	26.5
MST629		4.00	31.0

SECTION IV: TANKLESS & INDIRECT WATER HEATER PIPING (cont'd)

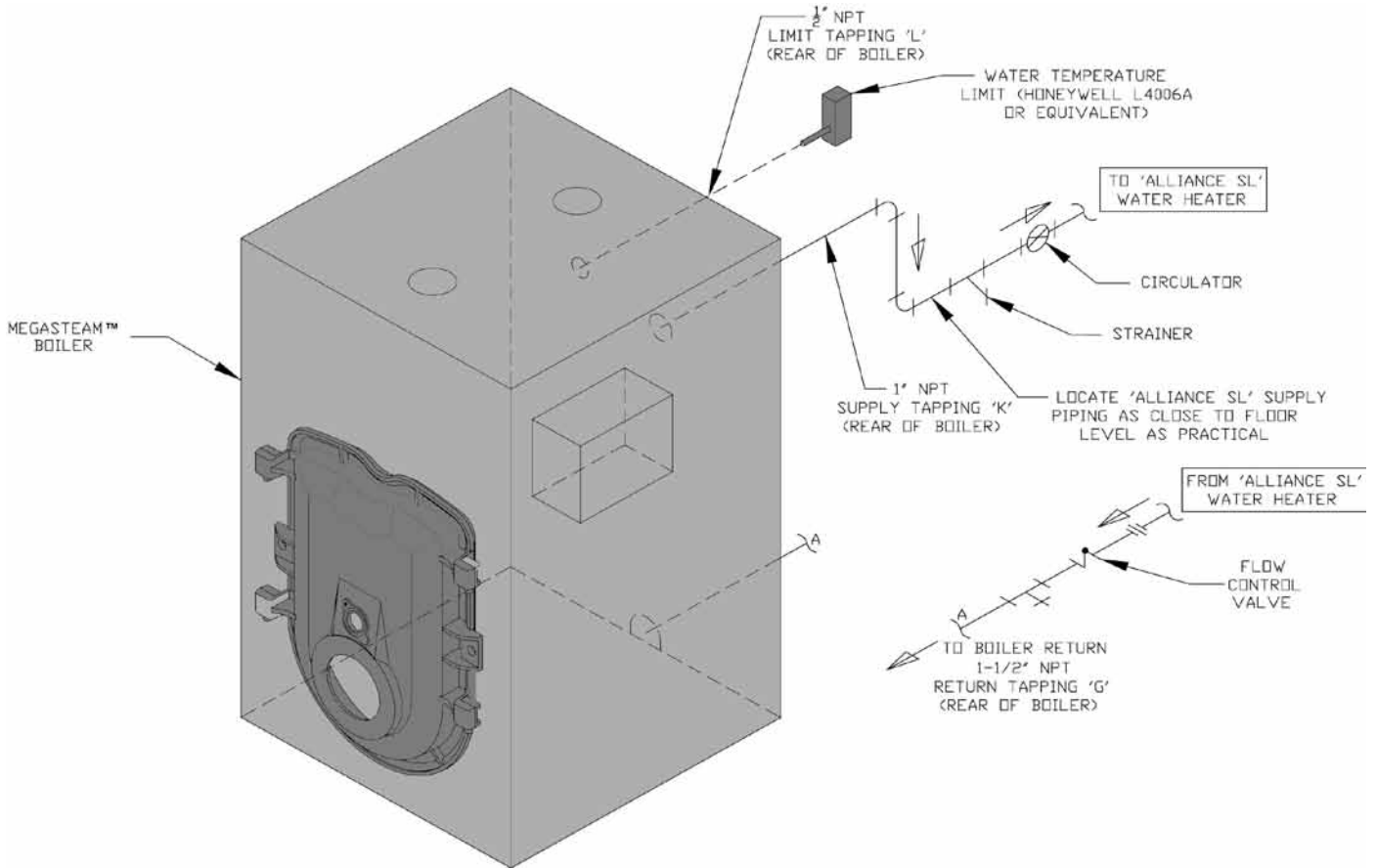

Figure 14: Alliance SL™ Water Heater Piping with MegaSteam™ Boiler

B. CONNECT ALLIANCE SL™ INDIRECT WATER HEATER PIPING as shown in Figure 14.

1. Refer to Alliance SL™ manual for additional information.

SECTION V: VENTING & AIR INTAKE PIPING

A. CHIMNEY VENTING

1. Chimney venting is an important part of a safe and efficient oil fired appliance system. Contact your local fire and building officials on specific requirements for restrictions and the installation of fuel oil burning equipment. In addition, consult with a professional knowledgeable on the requirements of NFPA 31 – Standard for the Installation of Oil-Burning Equipment and NFPA 211 - Standard for Chimneys, Fireplaces, Vents, and Solid Fuel-Burning Appliances for installations in the United States
2. The safe venting of oil fired boilers is dependent on many factors. Some of these factors include:
 - a. sufficient draft during the entire heating season to allow for the safe discharge of combustion by-products and;
 - b. suitable corrosion protection in the event of condensing flue gases. Only a trained and qualified contractor may install this product.
3. The MegaSteam™ can be vented into a fireclay tile-lined masonry chimney that meets requirements outlined in Paragraph 4 below. It can also be vented into a chimney constructed from type L vent or a factory built chimney that complies with the type HT requirements of UL 103. The chimney and vent pipe shall have a sufficient draft at all times, to assure safe proper operation of the boiler. See Figure 15 for recommended installation.

WARNING

Do not de-rate the boiler. Failure to fire the boiler at it's designed input may cause excessive condensation upon the interior walls of the chimney. In addition, the lower input may not create enough draft to adequately evacuate the by-products of combustion.

4. Chimney Inspection – Prior to the installation of any new or replacement fuel burning equipment the chimney shall be inspected by a qualified installer. The chimney shall be inspected for integrity as well as for proper draft and condensate control. Some jurisdictions require the use of a liner when changing fuel types. Some jurisdictions require the use of a liner even when the same fuel is used. At a minimum, the chimney shall be examined by a qualified person in accordance with the requirements of Chapter 11 of NFPA 211, Standard for Chimneys, Fireplaces, Vents, and Solid Fuel-Burning Appliances.

- a. Loose Mortar – Loose mortar could be an indication of a prior history of condensing flue gases upon the inside walls of the chimney. Colder climates are more susceptible to this condition. Under no circumstances shall a chimney of this condition be used until it meets the requirements of NFPA 211.
 - b. Unlined Chimney – Under no circumstances shall a chimney constructed of brick only be used. Only approved clay liners or listed chimney lining systems shall be used as specified in NFPA 31.
 - c. Abandoned Openings – Openings through the chimney wall that are no longer used shall be sealed in accordance to NFPA 211. Often abandoned openings are improperly sealed and usually covered by a gypsum wall covering.
 - d. Clean Chimney – Chimney shall be free of all loose debris.
5. Draft Regulator – the draft regulator supplied with the boiler must be used with this appliance. No other draft regulator shall be used. Refer to Figures 15 and 16.

B. CHIMNEY CONNECTOR

1. A chimney connector (vent pipe) is used to connect the boiler to the base of the chimney. The chimney connector should be kept as short as possible. The horizontal length of the chimney connector shall not be greater than 10 feet.

NOTE: Secure chimney connector to cast iron smokebox collar with three (3) #10 x ½" self drilling hex head TEK screws provided in appropriate Parts Carton. Locate screws around perimeter of connector as shown in Figure 15 and approximately ½" in from edge. Use drill with 5/16" hex bit to drive screws through connector and smokebox collar.

DANGER

The chimney and connector shall be inspected annually for signs of debris and corrosion. Loose mortar at the base of the chimney may be a sign of condensate damage to the chimney. A chimney professional shall be contacted immediately to examine the damage and recommend a solution. Long term operation while in this condition may cause a venting failure and force flue gases into the living space. If the chimney is to be relined use the recommendations in NFPA 31, Appendix E.

SECTION V: VENTING & AIR INTAKE PIPING (continued)

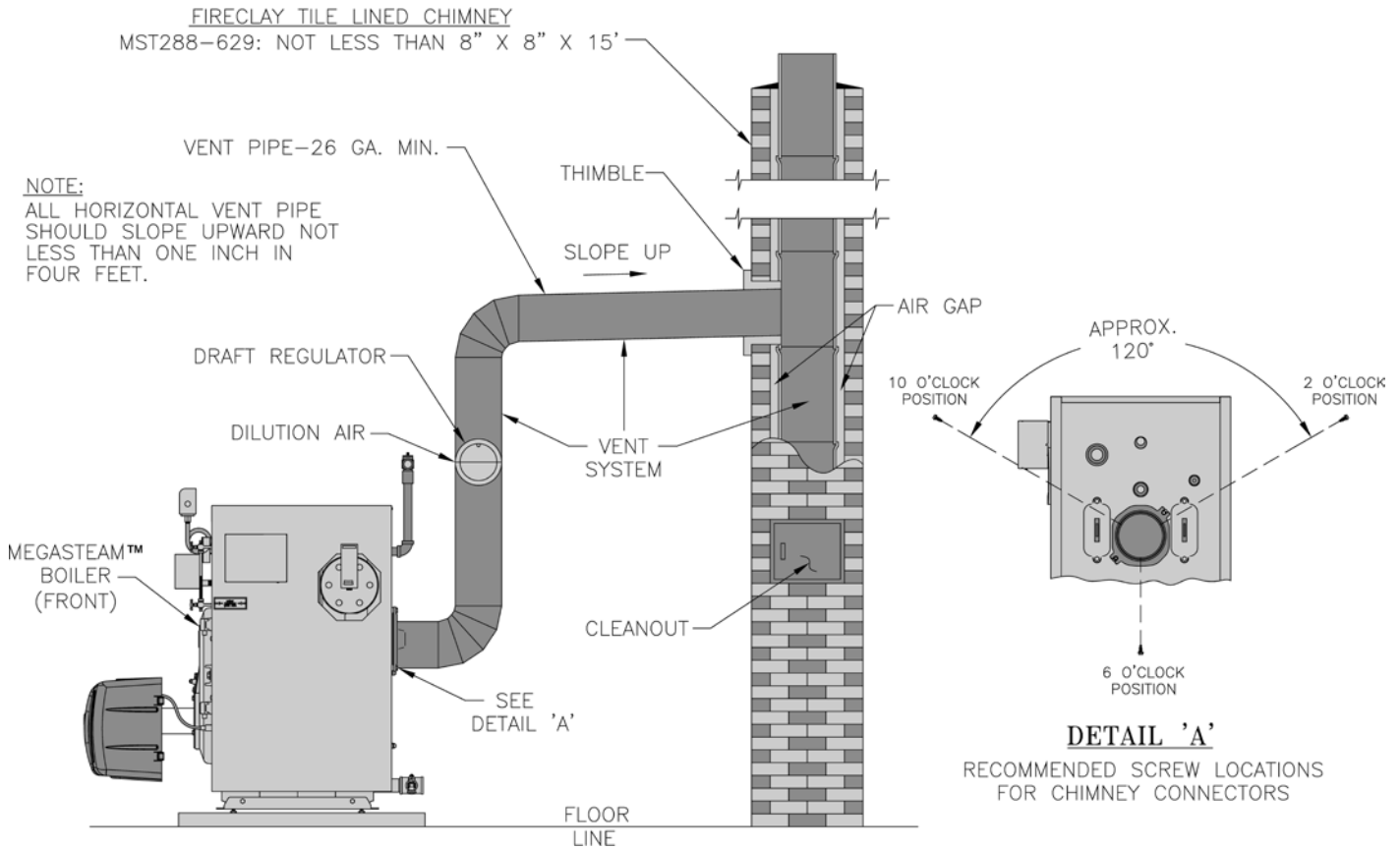

Figure 15: Recommended Vent Pipe Arrangement and Chimney Requirements

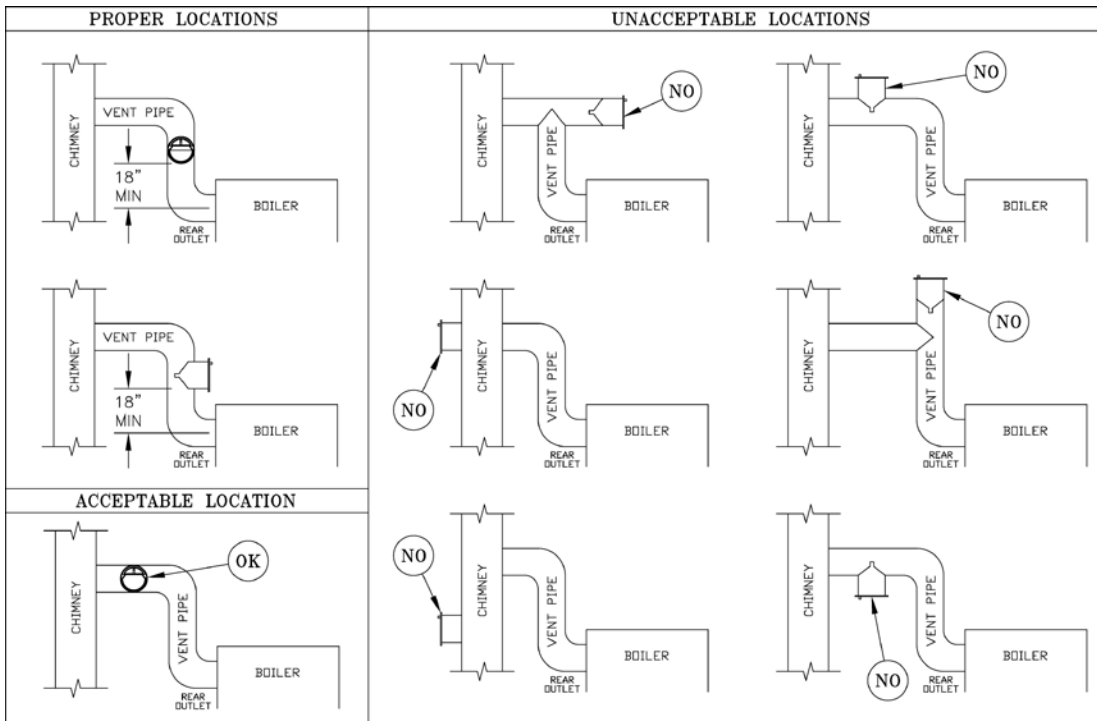

Figure 16: Proper and Improper Locations of Draft Regulator

SECTION V: VENTING & AIR INTAKE PIPING (continued)

2. Type B Chimney Connector - a type B chimney connector can be used to transmit the flue gases provided flue gas temperature entering the chimney connector is greater than 310°F.
3. Type L Chimney Connector - a type L vent or other suitable material shall be used for a chimney connector if the temperature or exiting temperature is less than 310°F.

DANGER

Any signs of condensate see page at the base of the chimney shall be inspected immediately. The discoloration may be a sign of chimney damage and must be remedied immediately.

C. DRAFT

1. The natural draft generated through a chimney is dependent on several factors including, chimney height, temperature of flue gases, cross section area of chimney, chimney wall insulation value, dilution air and total volume of flue gases, to name a few. Make sure that the boiler has been running for at least 5 minutes before measuring the draft.
2. Minimum Draft at Breech (Canopy) – The draft induced by a chimney must create at least a pressure of 0 (zero) inches water column (“ w.c.) at the pressure tapping on the canopy mounted on rear of boiler (see Figure 17). The pressure at the canopy **cannot** be positive since this could create a condition that allows flue gas by-products to escape from the draft regulator. A negative pressure reading up to -.03 inches water column is acceptable for proper operation. (See Tables 7 thru 7B, Burner Specifications at the rear of this manual for more details)
3. Minimum Overfire Pressure – The overfire pressure is another piece of information that is often measured, however this should be done for observation purposes only! The breech pressure must be used to qualify the draft condition. See Tables 7 thru 7B for more details as a guide. Actual draft and temperature measurements may be different then those values in the table.

D. STACK TEMPERATURE

1. The temperature of the flue gases has a significant effect on the amount of draft created in a vertical chimney as well as the propensity to create condensate. The higher the stack temperature, the greater the amount of draft that can be generated. A lower stack temperature not only reduces the amount of draft that can be created but it also increases the possibility that the flue gases could condense in the chimney connector or stack.

2. NFPA 31 has information to help the installer make an appropriate choice of venting materials. In some cases a chimney may have to be lined to create sufficient draft. In other cases, the chimney may have to be lined to prevent the corrosion of a masonry chimney. Consult with a chimney specialist knowledgeable on the requirements for chimney requirements in your area.

CAUTION

Any doubt on the condition of a chimney or it's ability to prevent the generation and accumulation of flue gas condensate, must be relined according to NFPA31.

CAUTION

Use the chimney venting tables as a guide. It is highly recommended that any borderline application should result in the relining of the chimney with a suitable liner that creates sufficient draft and to protect against corrosion caused by flue gas condensate.

3. Baffles – The efficiency of the boiler is based on the insertion of flue baffles supplied with your product. Under no circumstances are other baffles to be used on this product. The baffles are installed in the 2nd pass (two inner flueways) on the MST396, MST513 and MST629 Refer to Section II, Item E, Paragraph 1 for baffle installation. If there is any doubt on the application of this boiler on the intended chimney, consult with your local code officials. At

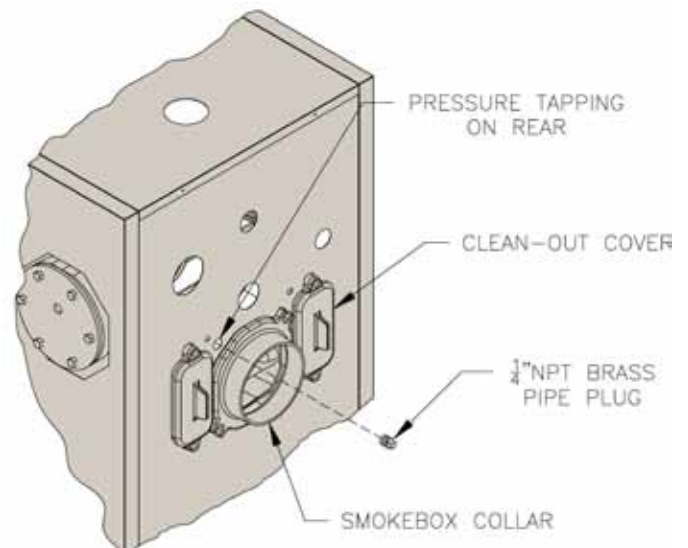

Figure 17: Smokebox Pressure Tapping for Checking Draft at Breech

SECTION V: VENTING & AIR INTAKE PIPING (continued)

a minimum, remove the baffles to increase the stack temperature. See Tables 7 thru 7B for temperature differential (ΔT) with baffles IN and OUT. In addition, the lower the CO_2 level the higher the stack temperature.

WARNING

Remove the baffles if there are any signs of condensation in the chimney or chimney connector. Consult with your local chimney professional for recommendations.

E. MINIMUM CLEARANCES

See Figure 2 for details regarding clearances to combustibles for the boiler.

F. OPTIONAL AIR INTAKE PIPING

INSTALLATION - All air for combustion can be supplied directly to the burner from outdoors providing that the criteria for chimney, vent connector and

minimum stack temperature outlined in this section can be maintained. **(ONLY AVAILABLE WITH BECKETT BURNER)**. Refer to Section I, Paragraph C, Steps 5 & 6 for optional air intake piping installation information.

WARNING

Using outdoor air in the middle of winter may result in lower stack temperatures and chimney degradation. Any signs of condensate seepage or discoloration at the base of chimney must be remedied immediately per the details outlined in this section.

Do not reduce size of air intake pipe.

Read, understand and follow combustion air instruction restrictions contained in the Pre-Installation Section of this manual.

SECTION VI: ELECTRICAL

DANGER

Positively assure all electrical connections are unpowered before attempting installation or service of electrical components or connections of the boiler or building. Lock out all electrical boxes with padlock once power is turned off.

WARNING

Failure to properly wire electrical connections to the boiler may result in serious physical harm.

Electrical power may be from more than one source. Make sure all power is off before attempting any electrical work.

Each boiler must be protected with a properly sized fused disconnect.

Never jump out or make inoperative any safety or operating controls.

WARNING

The interrupted hot (red) wire must be connected to the L terminal, the neutral (white) wire must be connected to the N terminal and the constant hot (black) wire must be connected to the auxiliary terminal or the primary safety control will be damaged.

A. GENERAL

1. Install wiring and electrically ground boiler in accordance with requirements of the authority having jurisdiction, or in absence of such requirements the National Electrical Code, ANSI/NFPA 70.
2. Refer to National Electric Code or Local Electric Codes for proper size and type of wire required. Follow Code.
3. A separate electrical circuit must be run from the main electrical service with an over-current device/disconnect in the circuit. A service switch is recommended and may be required by some local jurisdictions.
4. Use anti-short bushings on all wiring passing through boiler jacket, junction boxes and/or control boxes.
5. Use armored cable (BX) over all exposed line voltage wiring.

6. If an Alliance SL™ indirect water heater is used, use priority zoning. Do not use priority zoning for Hydro-Air Systems.

7. Wiring should conform to Figure 18.

- B. INSTALL A ROOM THERMOSTAT** on an inside wall about four feet above floor. Never install thermostat on an outside wall or where it will be influenced by drafts, hot or cold water pipes, lighting fixtures, television, rays of the sun or near a fireplace. Keep large furniture away from thermostat so there will be free movement of room air around this control. Heat Anticipator in Thermostat should be set to match the requirements of the control to which it is connected. See Figures 18 thru 19 for desired system and heat anticipator setting. If system tends to overheat above the thermostat's temperature setting, reduce heat anticipator setting by .1 or .2 amps. If system tends to short cycle without reaching desired room temperature, increase heat anticipator setting by .1 or .2 amps.

SECTION VI: ELECTRICAL (continued)

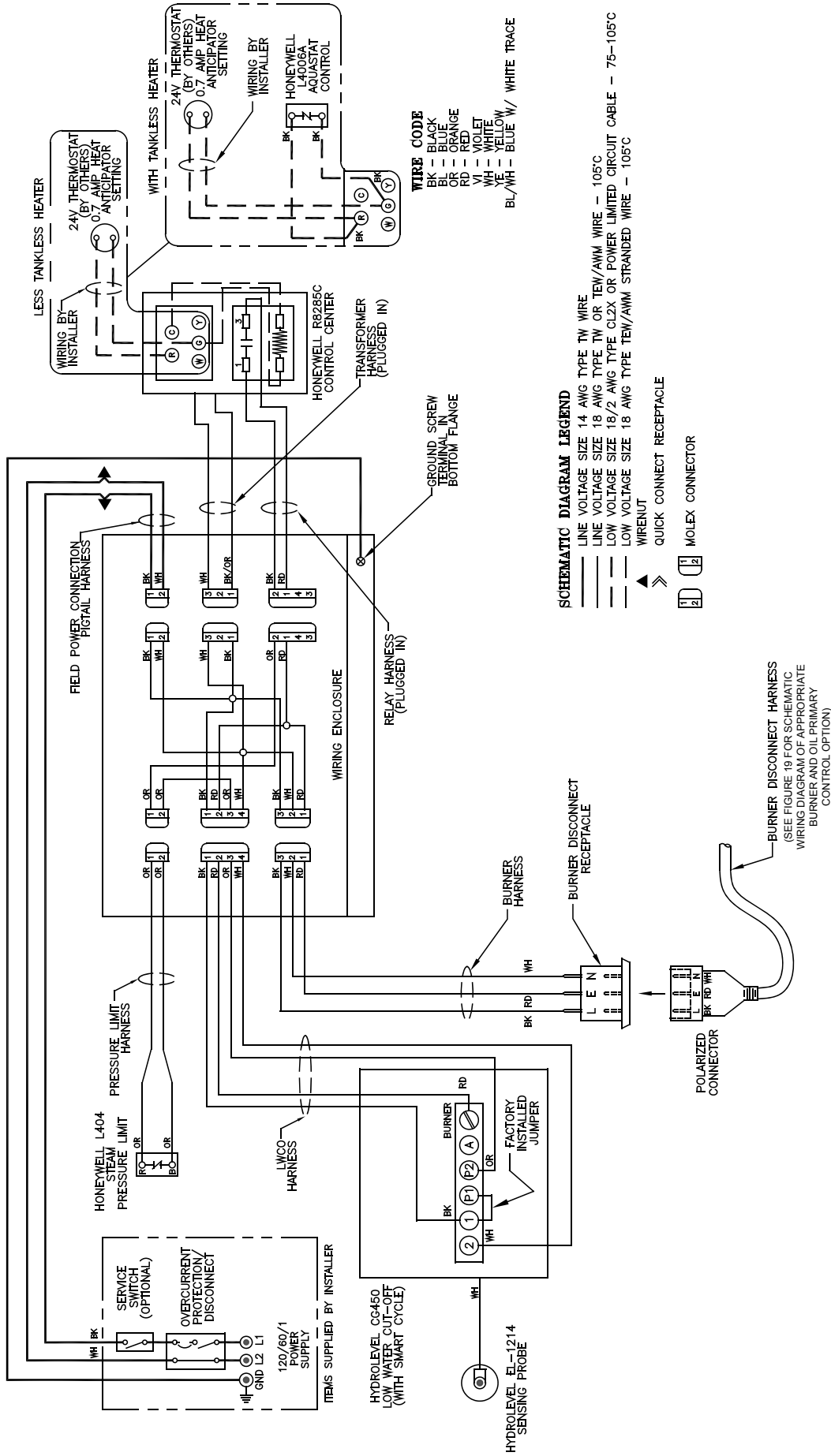

Figure 18: Wiring Diagram, Hydrolevel CG450 Probe LWCO

SECTION VI: ELECTRICAL (continued)

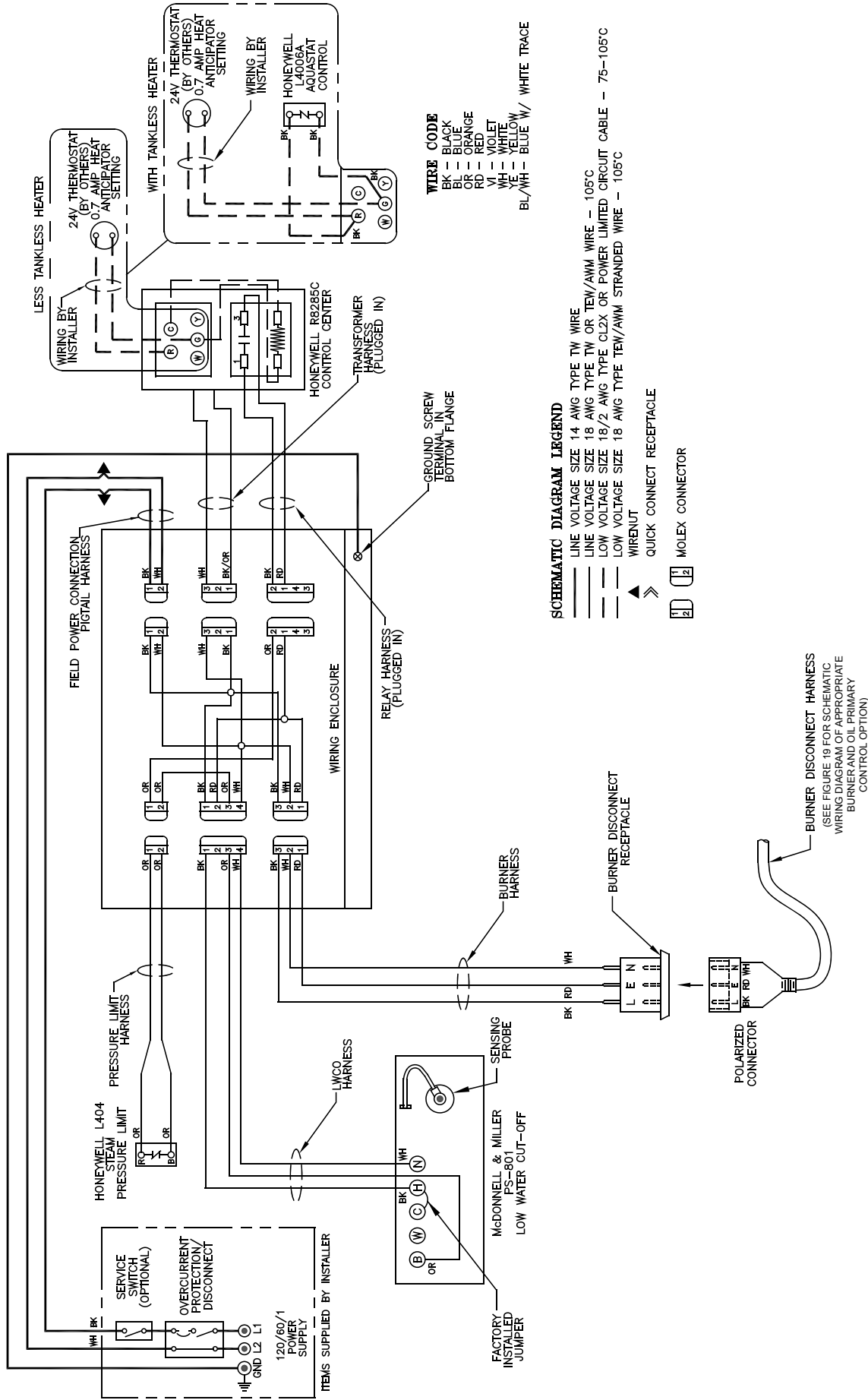

Figure 18A: Wiring Diagram, McDonnell & Miller PS-801 Probe LWCO

SECTION VI: ELECTRICAL (continued)

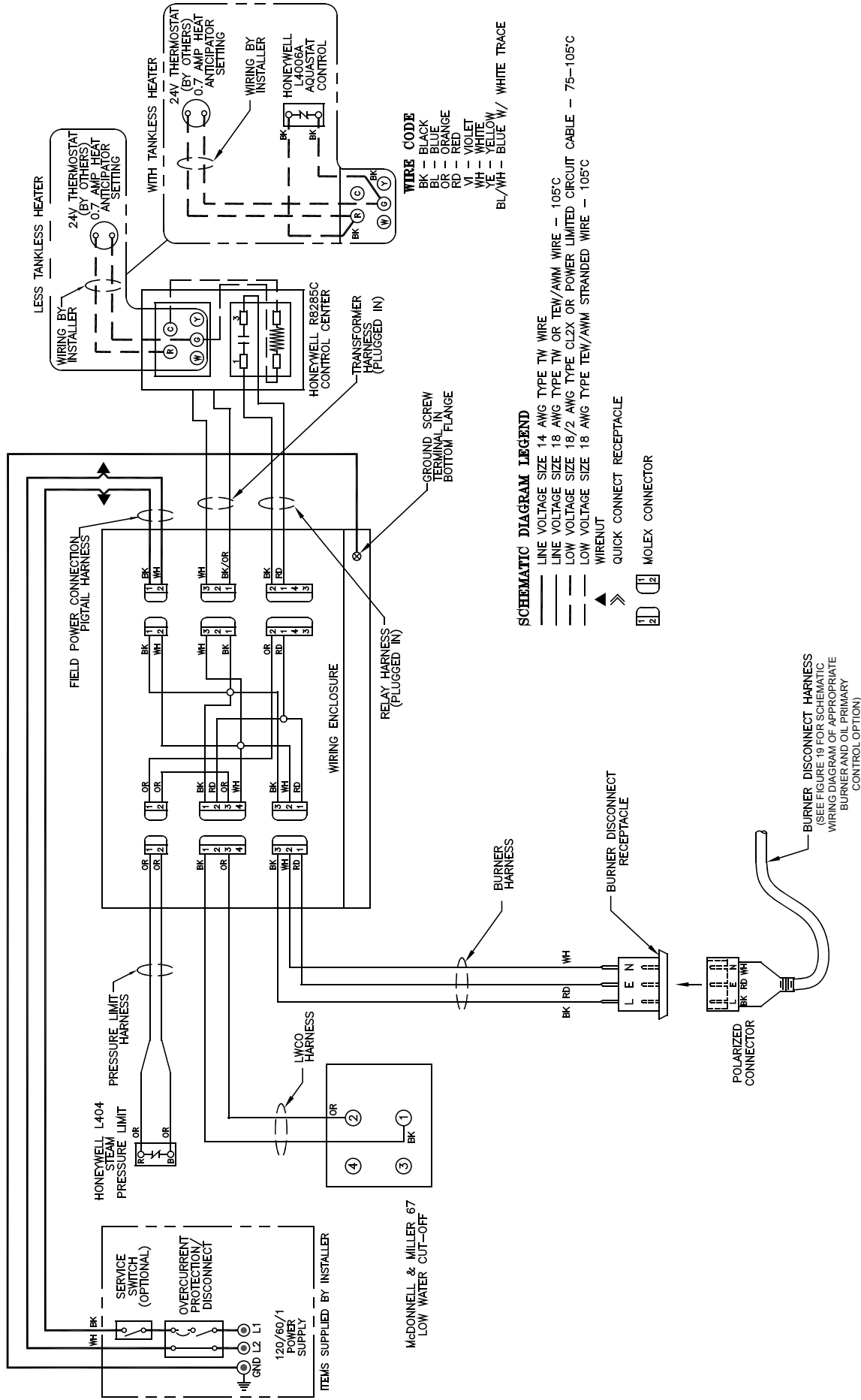

Figure 18B: Wiring Diagram, McDonnell & Miller #67 Float LWCO

SECTION VI: ELECTRICAL (continued)

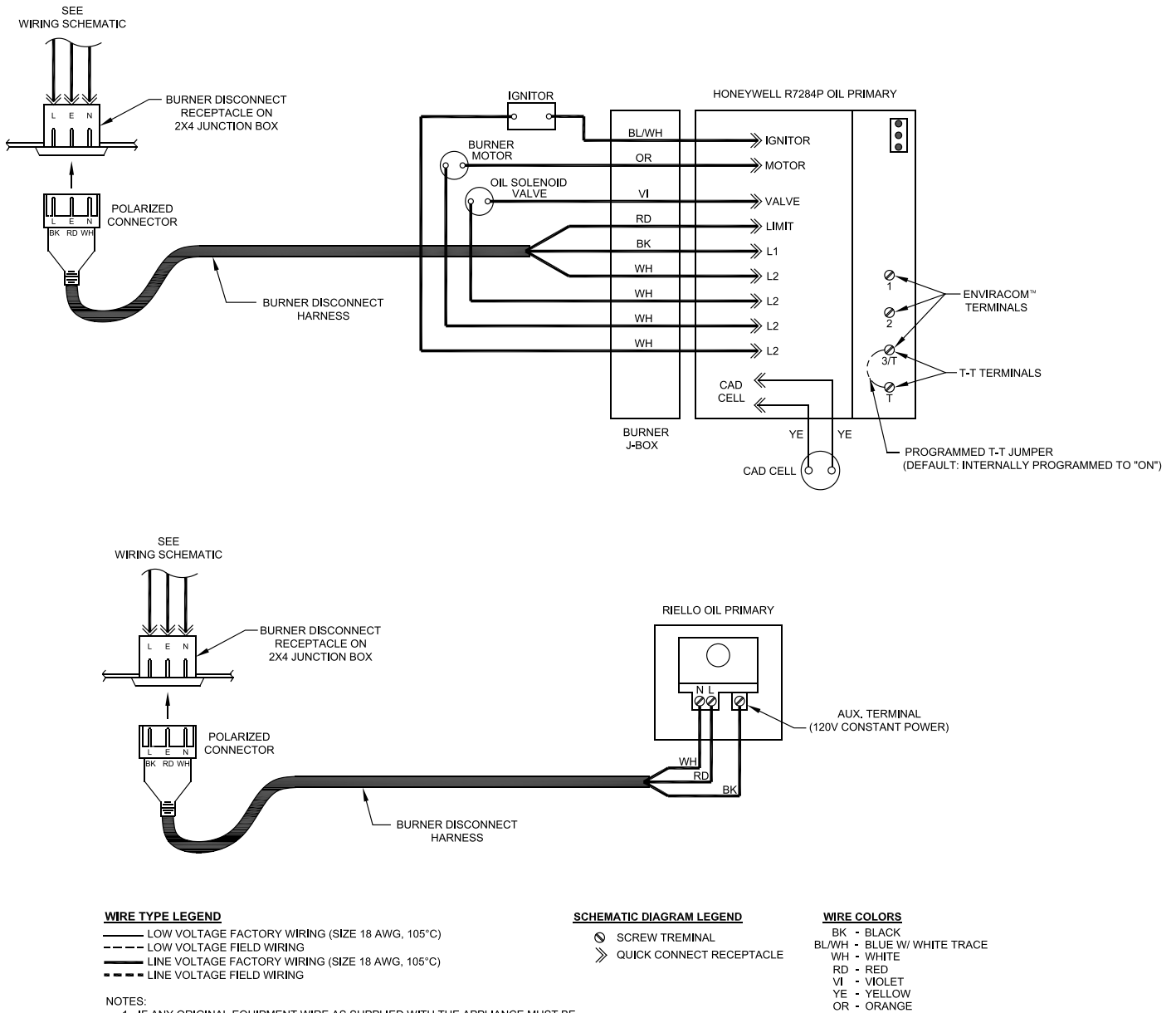

Figure 19: Wiring Diagram, All Burner Options with Various Oil Primary Controls

SECTION VI: ELECTRICAL (continued)

BOILER SEQUENCE OF OPERATION WITH PROBE LWCO (See Figure 18)

When the thermostat calls for heat, it energizes the R8285C Control Center relay which in turn energizes the cad cell primary control, bringing on the burner. The burner will operate in the following sequence: Prepurge for the first 10 seconds; fire until the thermostat is satisfied or the limit setting on the high limit is reached; post-purge for the last 10 seconds. When the pressure limit control restores the circuit on a drop in pressure, the burner will start if the thermostat is still calling for heat.

The probe low water cut-off will shut down the burner after a 10-15 second delay, if the water level in the boiler drops below the probe level.

The Hydrolevel CG450 low water cut-off will shut down the burner for 90 seconds every 10 minutes of firing time to allow water level to stabilize. If the water level is too low the burner will not be allowed to restart.

The probe low water cut-off will reset and restart the burner with a call for heat a few seconds after the water is returned to its normal level.

On burner start, if the cad cell does not see flame within approximately 15 seconds, primary control will shut burner down and enter into a recycle mode, after 60 seconds burner will restart and repeat trial for ignition. If after three (3) trials for ignition, flame is not detected, control will enter into restricted mode and must be reset manually before burner can be restarted.

When there is no demand for heat, the operating control will maintain the boiler water temperature at the selected setting for proper operation of the domestic water heater, if equipped with optional tankless heater.

BOILER SEQUENCE OF OPERATION WITH PROBE LWCO (See Figure 19)

When the thermostat calls for heat, it energizes the R8285C Control center relay, which in turn energizes the cad cell primary control, bringing on the burner. The burner will operate in the following sequence: Prepurge for the first 10 seconds; fire until the thermostat is satisfied or the limit setting on the high limit is reached; post-purge for the last 10 seconds. When the pressure limit control restores the circuit on a drop in pressure, the burner will start if the thermostat is still calling for heat.

The probe low water cut-off will shut down the burner after a 10-15 second delay, if the water level in the boiler drops below the probe level.

The probe low water cut-off will reset and restart the burner with a call for heat a few seconds after the water is returned to its normal level.

On burner start, if the cad cell does not see flame within approximately 15 seconds, primary control will shut burner down and enter into a recycle mode, after 60 seconds burner will restart and repeat trial ignition. If after three (3) trials for ignition, flame is not detected, control will enter into restricted mode and must be reset manually before burner can be restarted.

When there is no demand for heat, the operating control will maintain the boiler water temperature at the selected setting for proper operation of the domestic water heater, if equipped with optional tankless heater.

McDonnell & Miller PS-801 Terminals May be Lettered or Numbered as Follows:		
<u>Wire Color</u>	<u>Numbered Terminals</u>	<u>Lettered Terminals</u>
RD	5	B
BK	1	H
WH	2	N
Jumper	1-3	H-C

BOILER SEQUENCE OF OPERATION WITH FLOAT LWCO (See Figure 20)

When the thermostat calls for heat, it energizes the R8285C Control center relay, which in turn energizes the cad cell primary control, bringing on the burner. The burner will operate in the following sequence: Prepurge for the first 10 seconds; fire until the thermostat is satisfied or the limit setting on the high limit is reached; post-purge for the last 10 seconds. When the pressure limit control restores the circuit on a drop in pressure, the burner will start if the thermostat is still calling for heat. The low water cut-off will shut down the burner if the water level in the boiler drops too low. The control resets and restarts the burner with a call for heat a few seconds after the water is returned to its normal level.

On burner start, if the cad cell does not see flame within approximately 15 seconds, primary control will shut burner down and enter into a recycle mode, after 60 seconds burner will restart and repeat trial for ignition. If after three (3) trials for ignition, flame is not detected, control will enter into restricted mode and must be reset manually before burner can be restarted.

When there is no demand for heat, the operating control will maintain the boiler water temperature at the selected setting for proper operation of the domestic water heater, if equipped with optional tankless heater.

SECTION VII: OIL PIPING

A. GENERAL

1. Use flexible oil line(s) so the burner swing door can be opened without disconnecting the oil supply piping.
2. A supply line fuel oil filter is recommended as a minimum for all firing rates but a pleated paper fuel oil filter is recommended for the firing rates below 1.0 gph to prevent nozzle fouling.
3. Use Flared fittings only. Cast iron fittings cannot be used.

NOTICE

Do not use compression fittings.

Oil piping must be absolutely airtight or leaks or loss of prime may result. Bleed line and fuel unit completely.

Refer to your local jurisdictions regarding any special considerations for fuel supply requirements. In addition, refer to NFPA 31, Standard for the installation of Oil-Burning Equipment.

4. Use of a high efficiency micron filter (Garber or equivalent) in addition to a conventional filter is highly recommended.
5. Piping used to connect the oil burner to the oil supply tank shall not be smaller than 3/8" iron pipe or 3/8" OD copper tubing. Copper tubing shall have a .032" minimum wall thickness.

WARNING

Under no circumstances can copper with sweat style connectors be used.

NOTICE

Some jurisdictions require the use of a fusible shutoff valve at the tank and/or the burner. In addition, some jurisdictions require the use of a fusible electrical interlock with the burner circuit. Check your local Codes for special requirements.

B. SINGLE PIPE OIL LINES

1. Standard burners are provided with single-stage 3450 rpm fuel units with the bypass plug removed for single-pipe installations.
2. The single-stage fuel unit may be installed single-pipe with gravity feed or lift. Maximum allowable lift is 8 feet. See Figure 21.
3. Fuel Oil Line Deaerator – On many occasions a leaky oil delivery line can introduce air into the fuel oil supply system. This often creates a rough starting condition and can create a burner lockout state. In addition to fixing the leak, a fuel line deaerator can be installed to eliminate air. The single line from the fuel tank is connected to the deaerator. The burner pump must be connected to the deaerator as a two pipe system. Follow the oil pump manufacturer's recommendations for conversion to a two pipe system.

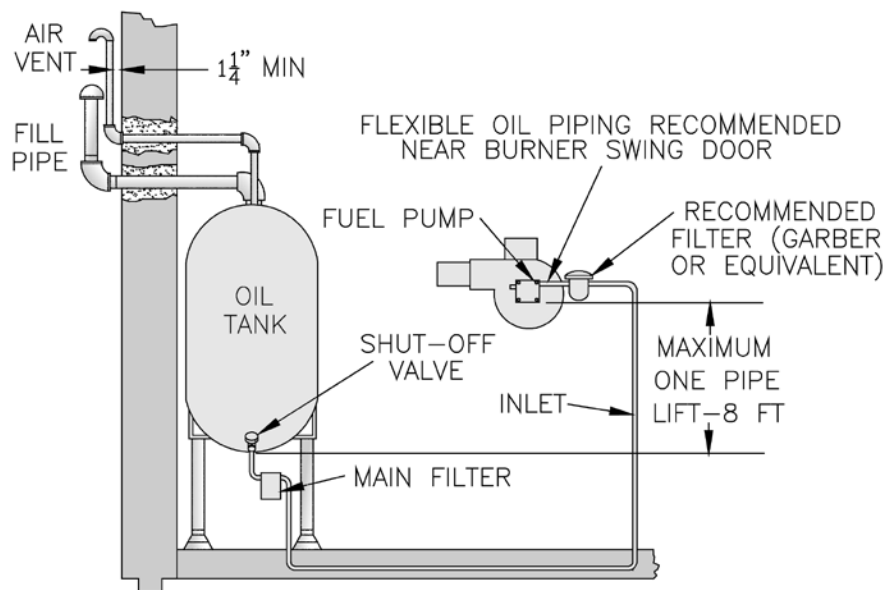

Figure 21: Single Pipe Oil Line

SECTION VII: OIL PIPING (continued)

C. TWO PIPE OIL LINES

1. For two piped systems, where more lift is required, the two-stage fuel unit is recommended. Table 5 (two-stage) and Table 6 (single-stage) show allowable lift and lengths of 3/8 inch and 1/2 inch OD tubing for both suction and return lines. Refer to Figure 22.
2. Follow the oil pump manufacturer's recommendations on the proper connections for a two pipe system. Some manufacturers require the insertion of a bypass plug.

3. Under no circumstances is a manual shutoff valve to be located on the return line of a two pipe system. Accidental closure of the return line will rupture the oil pump seals.

TABLE 5: TWO-STAGE UNITS (3450 RPM) - TWO PIPE SYSTEMS

Lift "H" (See Fig. 22)	Maximum Length of Tubing "H" + "R" (See Figure 22)	
	3/8" OD Tubing (3 GPH)	1/2" OD Tubing (3 GPH)
0'	93'	100'
2'	85'	100'
4'	77'	100'
6'	69'	100'
8'	60'	100'
10'	52'	100'
12'	44'	100'
14'	36'	100'
16'	27'	100'
18'	---	76'

TABLE 6: SINGLE-STAGE UNITS (3450 RPM) - TWO PIPE SYSTEMS

Lift "H" (See Fig. 21)	Maximum Length of Tubing "H" + "R" (See Figure 22)	
	3/8" OD Tubing (3 GPH)	1/2" OD Tubing (3 GPH)
0'	84'	100'
1'	78'	100'
2'	73'	100'
3'	68'	100'
4'	63'	100'
5'	57'	100'
6'	52'	100'
7'	47'	100'
8'	42'	100'
9'	36'	100'
10'	31'	100'
11'	26'	100'
12'	21'	83'
13'	---	62'
14'	---	41'

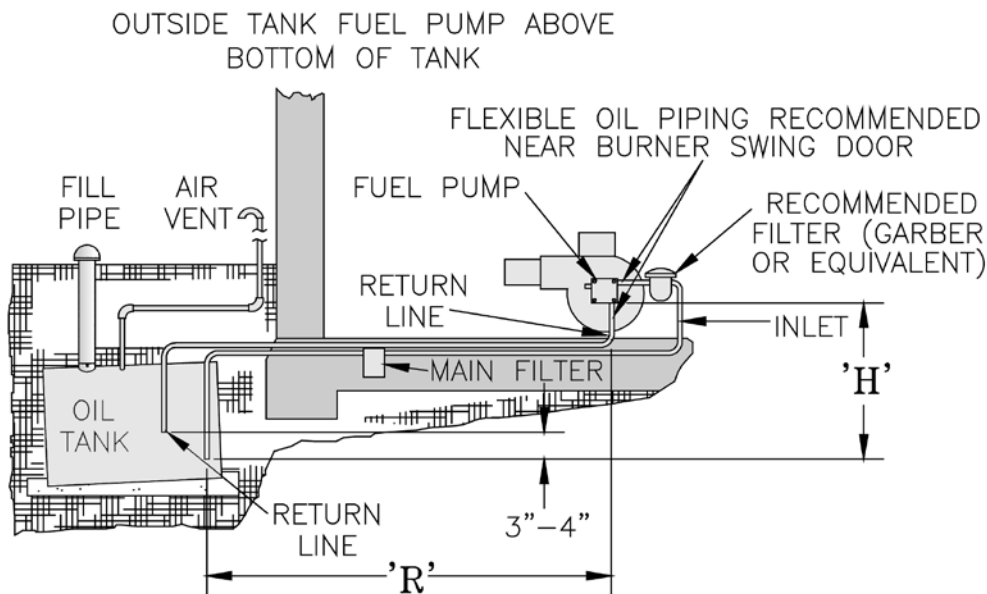

Figure 22: Two Pipe Oil Lines

SECTION VIII: SYSTEM START-UP

WARNING

All boilers equipped with burner swing door have a potential hazard which can cause severe property damage, personal injury or loss of life if ignored. Before opening swing door, turn off service switch to boiler to prevent accidental firing of burner outside the combustion chamber. Be sure to tighten swing door fastener completely when service is completed.

A. ALWAYS INSPECT INSTALLATION BEFORE STARTING BURNER.

1. Verify that the venting, water piping, oil piping, and electrical system are installed properly. Refer to Installation Instructions contained in this manual.
2. Confirm all electrical, water and oil supplies are turned off at the source and that the vent is clear from obstructions.

WARNING

Completely read, understand and follow all instructions in this manual before attempting start up.

B. FILL HEATING SYSTEM WITH WATER.

NOTICE

It is important, especially in a steam system, to properly remove the oil and dirt from the system. Failure to clean the system can result in erratic water lines and surging.

CLEAN HEATING SYSTEM if boiler water or condensate return water is dirty or if erratic water lines or surging exist after a few days of boiler operation.

Refer to Maintenance and Service Instructions Section of this manual for proper cleaning instructions for steam and water boilers.

1. STEAM BOILERS — Fill boiler to normal water line. Refer to Figure No. 1.

WARNING

The maximum operating pressure of this boiler is posted on the ASME Data Label located on the top of the boiler. Never exceed this pressure. Do not plug relief valve.

C. CHECK CONTROLS, WIRING AND BURNER to be sure that all connections are tight and burner is rigid, that all electrical connections have been completed and fuses installed, and that oil tank is filled and oil lines have been tested.

D. SET CONTROLS with burner service switch turned "OFF".

1. SET ROOM THERMOSTAT about 10° above room temperature.
2. PRESS RED RESET BUTTON on front of burner cover, hold for one (1) second and release to reset primary control.
3. On STEAM BOILERS:
 - a. With an L404F1367 - set cut-out pressure (MAIN scale) on the pressure limit for (1) PSI and differential pressure (DIFF.) for .5 PSI. These pressures may be varied to suit individual requirements of the system.
4. On STEAM BOILERS WITH TANKLESS DOMESTIC WATER HEATERS, set boiler water temperature dial on L4006 operating control at 190°F (max.). Set differential at 10°.

E. ADJUST OIL BURNER BEFORE STARTING.

1. CHECK BURNER AIR BAND, AIR SHUTTER AND HEAD SETTING (if applicable), readjust if necessary, see Tables 7 thru 7B at rear of manual.
2. OPEN ALL OIL LINE VALVES.
3. Attach a plastic hose to fuel pump vent fitting and provide a pan to catch the oil.
4. OPEN FLAME OBSERVATION PORT COVER on burner swing door.

F. START OIL BURNER.

1. Open vent fitting on fuel pump.
2. PRESS RED RESET BUTTON on front of burner cover, hold for one (1) second and release to reset primary control.
3. TURN 'ON' BURNER service switch and allow burner to run until oil flows from vent fitting in a SOLID stream without air bubbles for approximately 10 seconds.

NOTE: For Primary Control "Pump Priming Cycle" details, see Paragraph I, No. 2., Step a., Item *ii*.

4. Close vent fitting and burner flame should start immediately after prepurge is completed. Prepurge prevents burner flame until 15 seconds has elapsed after initial power is applied to burner. During prepurge the motor and igniter will operate but the oil valve will remain closed. Refer to Oil Primary Control Instructions for more details.

SECTION VIII: SYSTEM START-UP (continued)

5. Adjust oil pressure.
 - a. When checking a fuel unit's operating pressure, a reliable pressure gauge may be installed in either the bleeder port or the nozzle port. See Figure 23.
 - b. Locate oil pressure adjusting screw and turn screw to obtain proper pump pressure, refer to Tables 7 thru 7B at rear of manual.
 - c. To check the cut-off pressure, deadhead a reliable pressure gauge onto the copper connector tube attached to the nozzle port. Run the burner for a short period of time. Shut the burner off. The pressure should drop and hold.
 - d. Remove the gauge and install bleeder port and/or reconnect the nozzle port line.

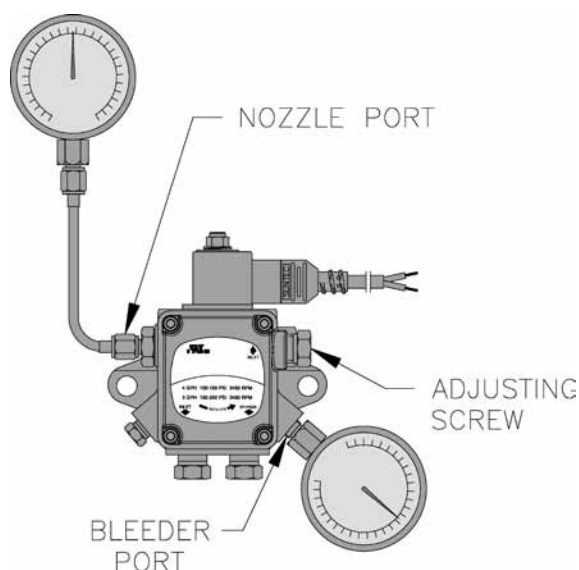

Figure 23: Adjusting Fuel Pump Pressure

G. ADJUST OIL BURNER WHILE OPERATING. (flame present)

1. ADJUST DRAFT REGULATOR for a draft of zero inches (water gauge) in the canopy (see Figure 15) after chimney has reached operating temperature and while burner is running. (At least five minutes) See Tables 7 thru 7B at rear of manual for details.
 2. READJUST THE AIR BAND on burner for a light orange colored flame while the draft in the canopy is zero inches water column ("w.c."). Use a smoke tester and adjust air for minimum smoke (not to exceed #1) with a minimum of excess air. Make final check using suitable instrumentation to obtain a CO₂ of 11.5 to 12.5% with draft of zero inches water column ("w.c.") (water gauge) in canopy. These settings will assure a safe and efficient operating condition. If the flame appears stringy instead of a solid fire, try another nozzle of the same type. Flame should be solid and compact. After all adjustments are made recheck for a draft of zero inches water column ("w.c.") in the canopy. Replace plug at completion. See Tables 7 thru 7B (at rear of this manual) for details regarding the overfire pressure when baffles are both installed and removed.
3. READJUST THE HEAD SETTING only if necessary.
 - a. MST288 & MST396:
Beckett MB(L1) Head burner has a fixed head which is non-adjustable.
 - b. MST513 & MST629:
Beckett MD(V1) (variable) Head burners have the ability to control air by moving the head. It might be necessary to move the head forward or back one position at a time to optimize the smoke and CO₂ readings. See Figure 24.
 4. READJUST THE TURBULATOR SETTING only if necessary. (Riello Burner only)
 - a. Move the turbulator setting forward or back one position at a time to optimize the smoke and CO₂ readings.
 5. TURN "OFF" BURNER and remove pressure gauge. Install gauge port/bleeder plug and tighten. Start burner again.

WARNING

Do not loosen or remove any oil line fittings while burner is operating.

6. FLAME FAILURE

The MegaSteam™ boiler controls operate the burner automatically. If for unknown reasons the burner ceases to fire and the reset button on the primary control has tripped, the burner has experienced ignition failure.

WARNING

Do not attempt to start the burner when excess oil has accumulated, when the boiler is full of vapor, or when the combustion chamber is very hot.

H. CHECK FOR CLEAN CUT OFF OF BURNER.

1. AIR IN THE OIL LINE between fuel unit and nozzle will compress when burner is on and will expand when burner stops, causing oil to squirt from nozzle at low pressure as the burner slows down and causing nozzle to drip after burner stops. Usually, cycling the burner operation about 5 to 10 times will eliminate air from the oil line.

SECTION VIII: SYSTEM START-UP (continued)

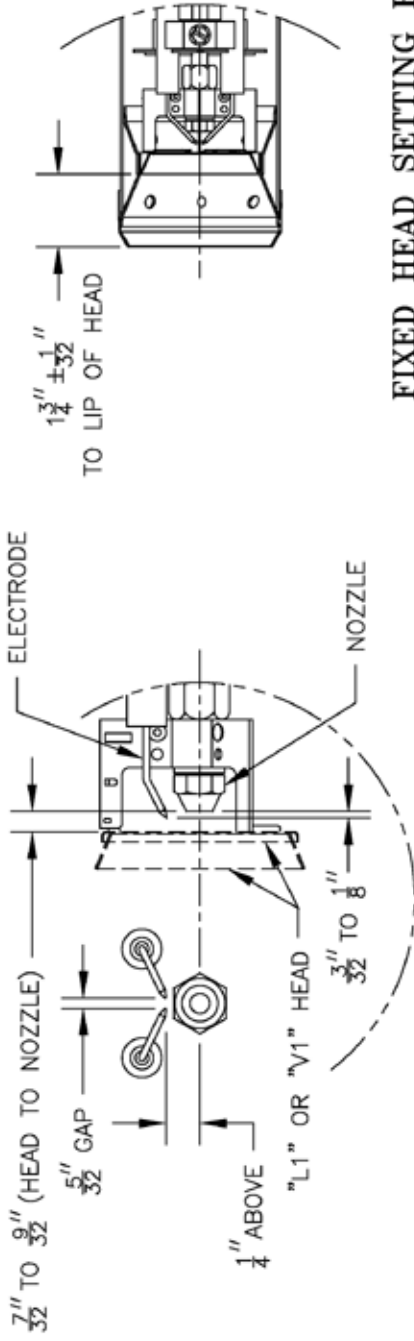

**FIXED HEAD SETTING FOR
MST288 AND MST396 WITH
L1 HEAD**

**ELECTRODE ADJUSTMENT
(FOR ALL MODELS)**

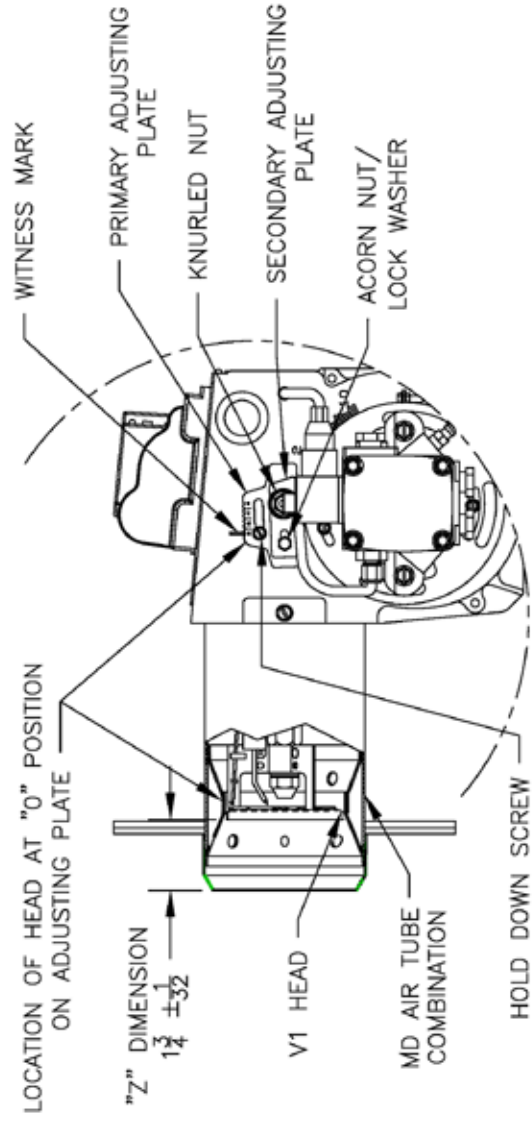

**HEAD SETTING (AT "0") FOR
MST513 AND MST629 WITH V1 HEAD**

Figure 24: "L1" and "V1" Head Electrode Positioning and Gun Setting (Beckett AFG)

SECTION VIII: SYSTEM START-UP (continued)

2. IF NOZZLE CONTINUES TO DRIP, repeat Paragraph H, No. 1. If this does not stop the dripping, remove cut-off valve and seat, and wipe both with a clean cloth until clean, then replace and readjust oil pressure. If dripping or after burn persist replace fuel pump.

I. CHECK THERMOSTAT OPERATION.

Raise and lower thermostat setting as required to start and stop burner.

WARNING

Before installation of the boiler is considered complete, the operation of all boiler controls must be checked, particularly the primary control and high limit control.

J. VERIFY HONEYWELL OIL PRIMARY FEATURES

using procedures outlined in Instructions furnished with control or instructions as follows:

1. R7284 FEATURES AND CONTROLS
 - a. The Oil Primary is a microprocessor-based control. The indicator light provides diagnostic information for lockout, recycling and patented cad cell status.
 - b. Pump Priming Cycle: To facilitate purging air from the oil lines and filters. The R7284 can be placed in a purge routine by pressing and releasing the up arrow button during the Trial For Ignition. "Pump Prime" is shown on the oil primary display along with the time left on the Trail for Ignition (TFI). Pressing the up arrow button adds a minute to the TFI time for a maximum of 10 additional minutes (press the up arrow button 10 times). Pressing the down arrow subtracts a minute from the TFI time (see Figure 25).

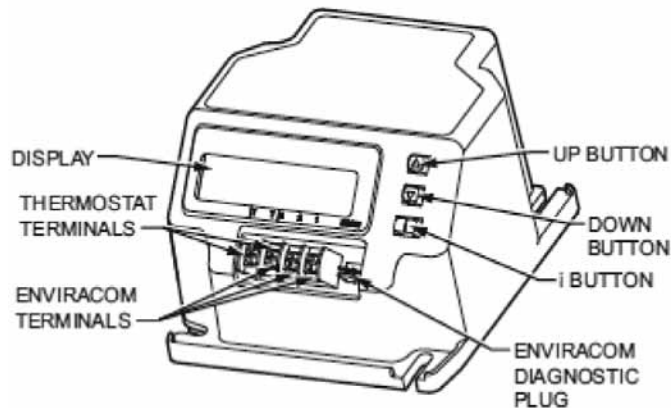

Figure 25: R7284 Oil Primary Terminals, Display and Function Buttons

- c. Limited Recycle: This feature limits the number of recycle trials (for each call for heat) to a maximum of three trials. If the flame is lost three times and does not successfully satisfy a call for heat, the Oil Primary locks out.
- d. Limited Reset (Restricted Mode): In order to limit the accumulation of unburned oil in the combustion area, the control can only be reset three times. The reset count returns to zero each time a call for heat is successfully completed.
- e. All R7284 models have internal "TT Configured ON" parameters set to "ON".
- f. The R7284 has an LCD display and simply displays lockout and flame status on it.
- g. Cad Cell Resistance Check: For proper operation it is important that the cad cell resistance is below 1600 ohms. Cad Cell Resistance (ohms) is measured by the oil primary. The thresholds are:
 - < 1600 Ohms Normal operation
 - > 1600 Ohms Service burner soon
 - > 6100 Ohms Flame loss, burner shuts down
 - > 9999 Ohms Check for broken cell or wire.R7284 displays resistance in ohms during Running Mode.

2. CHECK OIL PRIMARY CONTROL

CAUTION

Due to the potential hazard of line voltage, only a trained, experienced service technician should perform the following safety checks.

This control contains no field-serviceable parts. Do not attempt to take it apart. Replace entire control if operation is not as described.

- a. Preliminary Steps
 - Check wiring connections and power supply.
 - Make sure power is on to the controls.
 - Make sure limit control is closed.
 - Check contacts between ignitor and the electrodes.
 - Check the oil pump pressure.
 - Check the piping to the oil tank.
 - Check the oil nozzle, oil supply and oil filter.
- b. Check Safety Features
 - Safe Start:
 - Place a jumper across cad cell terminals.
 - Follow procedure to turn on burner. Burner must not start, indicator light turns on and control remains in Idle Mode.
 - Remove jumper.

SECTION VIII: SYSTEM START-UP (continued)

c. Simulate Ignition or Flame Failure:

- Follow procedure to turn on burner.
- Check cad cell resistance. If resistance is below 1600 OHMS and burner runs beyond safety cut-out time, cad cell is good.
- If safety switch shuts down burner and resistance is above 1600 OHMS, open line switch to boiler. Access cad cell under ignitor, clean face of cad cell and see that cell is securely in socket, see Figure 26. Check gasket around perimeter of ignitor lid for proper seal. If gasket is missing or damaged, replace gasket. Room light can effect cad cell resistance. Reset safety switch.

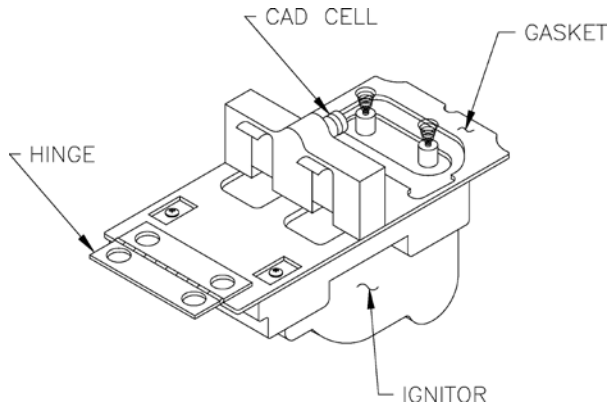

Figure 26: Cad Cell Location

- Close line switch to boiler. If burner starts and runs beyond safety switch cut-off time, cell is good. If not, install new cell.
 - Close hand valve in oil supply line.
 - Failure occurs, device enters Recycle Mode.
 - Device tries to restart system after approximately 60 seconds.
 - After third Recycle Mode trial, safety switch locks out within safety switch timing indicated on label and control enters Restricted Mode.
- d. Power Failure Check: After Flame is established, turn the power off to the control/burner. The burner should shut down safely. When power is restored a normal ignition sequence should be started.

WARNING

Cad Cell Jumper must be removed after this check.

- K. **IF CONTROLS DO NOT MEET REQUIREMENTS** outlined in Paragraph I., replace control and repeat checkout procedures.

Important Product Safety Information **Refractory Ceramic Fiber Product**

Warning:

The Repair Parts list designates parts that contain refractory ceramic fibers (RCF). RCF has been classified as a possible human carcinogen. When exposed to temperatures about 1805°F, such as during direct flame contact, RCF changes into crystalline silica, a known carcinogen. When disturbed as a result of servicing or repair, these substances become airborne and, if inhaled, may be hazardous to your health.

AVOID Breathing Fiber Particulates and Dust

Precautionary Measures:

Do not remove or replace RCF parts or attempt any service or repair work involving RCF without wearing the following protective gear:

1. A National Institute for Occupational Safety and Health (NIOSH) approved respirator
 2. Long sleeved, loose fitting clothing
 3. Gloves
 4. Eye Protection
- Take steps to assure adequate ventilation.
 - Wash all exposed body areas gently with soap and water after contact.
 - Wash work clothes separately from other laundry and rinse washing machine after use to avoid contaminating other clothes.
 - Discard used RCF components by sealing in an airtight plastic bag. RCF and crystalline silica are not classified as hazardous wastes in the United States and Canada.

First Aid Procedures:

- If contact with eyes: Flush with water for at least 15 minutes. Seek immediate medical attention if irritation persists.
- If contact with skin: Wash affected area gently with soap and water. Seek immediate medical attention if irritation persists.
- If breathing difficulty develops: Leave the area and move to a location with clean fresh air. Seek immediate medical attention if breathing difficulties persist.
- Ingestion: Do not induce vomiting. Drink plenty of water. Seek immediate medical attention.

SECTION IX: MAINTENANCE AND SERVICE INSTRUCTIONS

A. MAINTENANCE OF LOW WATER CUT-OFF DEVICES

WARNING

Probe and float type low water cut-off devices require annual inspection and maintenance.

1. PROBE TYPE LOW WATER CUT-OFF

Although these devices are solid state in their operation, the probe is exposed to possible contamination in the boiler water and subject to fouling.

It is important to physically remove the probe from the boiler tapping annually and inspect that probe for accumulation of scale or sediment.

Follow these steps to inspect, clean and/or replace the probe:

- a. Turn off electric service to the boiler.
- b. Drain boiler water to a level below the tapping for the probe.
- c. Disconnect wiring connections between the low water cut-off control and the probe.
- d. Remove the low water cut-off control from the probe.

DANGER

Assure that the boiler is at zero pressure before removing the LWCO probe. Do not rely on the pressure gauge to indicate that the boiler is at zero pressure. Open the safety valve to relieve all internal pressure prior to proceeding. Safety valve discharge piping must be piped such that the potential for burns is eliminated.

- e. Unscrew the probe from the boiler tapping.
- f. Inspect that portion of the probe that is exposed to the boiler water for a scale or sediment buildup.
- g. Light deposits may be removed by wiping the probe with a damp cloth. Wiping the probe with a cloth soaked in vinegar will remove more tenacious lime deposits. The most stubborn deposits may be removed from the probe by using a diluted amount, 3 parts of water to 1 part of phosphoric acid (H_2PO_4).

CAUTION

Exercise caution when handling phosphoric acid and follow the instruction label on its container.

- h. Clean the pipe threads of the probe to remove old, hardened pipe dope and other foreign matter.
- i. Apply a moderate amount of good quality pipe dope to the pipe threads on the probe, leaving the two end threads bare. Do not use PTFE (Teflon) tape.
- j. Screw the probe into the boiler tapping.
- k. Mount the low water cut-off control on the probe.
- l. Reconnect the control to probe wiring.
- m. Fill the boiler to its normal waterline.
- n. Add boiler water treatment compound as needed (refer to Paragraph B.).
- o. Restore electric service to the boiler.
- p. Fire burner to bring the water in the boiler to a boil to drive off free oxygen.
- q. **WARNING — BEFORE RETURNING BOILER TO SERVICE:** Follow the low water cut-off check out procedure in Section VIII, Paragraph I, No. 4.

2. FLOAT TYPE LOW WATER CUT-OFF

During the heating season, if an external low water cut-off is on the boiler, the blow off valve should be opened once a month (use greater frequency where conditions warrant), to flush out the sediment chamber so the device will be free to function properly.

Low water cut-offs and water feeders should be dismantled annually by qualified personnel, to the extent necessary to insure freedom from obstructions and proper functioning of the working parts. Inspect connecting lines to boiler for accumulation of mud, scale, etc., and clean as required. Examine all visible wiring for brittle or worn insulation and make sure electrical contacts are clean and that they function properly. Give special attention to solder joints on bellows and float when this type of control is used. Check float for evidence of collapse and check mercury bulb (where applicable) for mercury separation or discoloration. *Do not attempt to repair mechanisms in the field.* Complete replacement mechanisms, including necessary gaskets and installation instructions are available from the manufacturer.

B. BOILER AND SYSTEM CLEANING INSTRUCTIONS FOR TROUBLE FREE OPERATION

1. STEAM BOILERS

- a. Oil, greases & sediments which accumulate in a new boiler and piping must be removed in order to prevent an unsteady water line and carry over of the water into the supply main above boiler.

SECTION IX: MAINTENANCE AND SERVICE INSTRUCTIONS (cont'd)

Operate the boiler with steam in the entire system for a few days allowing the condensate to return to the boiler. If the condensate can temporarily be wasted, operate boiler only for the length of time it takes for condensate to run clear. If the latter cannot be achieved or if the condensate is returned to the boiler, boil out the boiler using the SURFACE BLOW-OFF connection, see Figure 7.

- i.* Drain boiler until 1" of water is visible in gauge glass. Run temporary 1½" NPT pipe line from the surface blow-off connection to an open drain or some other location where hot water may be discharged safely. Do not install valve in this line.
- ii.* Drain about 5 gallons of hot water from boiler into a container and dissolve into it an appropriate amount of recommended boil out compound. Remove safety valve & add solution to boiler water thru exposed tapping using a funnel.

NOTICE

Check with local authorities or consult local water treatment services for acceptable chemical cleaning compounds.

- iii.* Start burner and operate sufficiently to boil the water without producing steam pressure. Boil for about 5 hours. Open boiler feed pipe sufficiently to permit a steady trickle of water from the surface blow-off pipe. Continue this slow boiling and trickle of overflow for several hours until the water coming from the overflow is clear.
 - iv.* Stop burner and drain boiler in a manner and to a location that hot water can be discharged with safety.
 - v.* Refill boiler to normal water line. If water in gauge glass does not appear to be clear, repeat steps (*i.* thru *iii.*) and boil out the boiler for a longer time.
- b.* Low pressure steam boilers such as the MegaSteam™, should be maintained with appropriate water treatment compounds. Add suitable water treatment compounds as recommended by your qualified water treatment company.
 - c.* Remove temporary surface blow-off piping, plug tapping and reinstall safety valve. Boil or bring water temperature to 180°F promptly in order to drive off the dissolved gases in the fresh water.
 - d.* If unsteady water line, foaming or priming persist, install gate valve in Hartford Loop and

drain valves in return main and at boiler as shown in Figure 12 and proceed as follows:

- i.* Connect hoses from drain valves to floor drain. Close gate valve in Hartford Loop and open drain valve in return main. Fill boiler to normal water level, turn on oil burner and operate boiler at this water level for at least 30 minutes after the condensate begins to run hot, then turn off burner.
Close all radiator valves. Remove all supply main air valves and plug the openings in supply main.
- ii.* Draw about 5 gallons of hot water from boiler into a container and dissolve into it the appropriate amount of a recommended boilout compound. Remove safety valve from boiler and pour this solution into boiler, then reinstall safety valve.
- iii.* Turn on oil burner and keep operating while feeding water to boiler slowly. This will raise water level in boiler slowly so that water will be boiling hot and will rise slowly into supply main and back through return main, flowing from drain hose at about 180°F. Continue until water runs clear from drain hose for at least 30 minutes.
- iv.* Stop feeding water to boiler but continue operating oil burner until excess water in boiler flows out through supply main and water lowers (by steaming) until it reaches normal level in boiler. Turn off oil burner. Drain boiler. Open all radiator valves. Reinstall all supply main air valves. Open gate valve in Hartford Loop.
- v.* When boiler has cooled down sufficiently (crown sheet of sections are not too hot to touch), close the drain valves at boiler and in return main and feed water slowly up to normal level in boiler. Turn on oil burner and allow boiler to steam for 10 minutes, then turn off burner. Draw off one quart of water from bottom gauge glass fitting and discard. Draw off another quart sample and if this sample is not clear, repeat the cycle of draining the boiler and return main and refilling the boiler until sample is clear.
- vi.* If the boiler water becomes dirty again at a later date due to additional sediment loosened up in the piping, close gate valve in Hartford Loop, open drain valve in return main, turn on oil burner and allow Condensate to flow to drain until it has run clear for at least 30 minutes while feeding water to boiler so as to maintain normal water level. Turn off oil burner, drain boiler,

SECTION IX: MAINTENANCE AND SERVICE INSTRUCTIONS (cont'd)

open gate valve in Hartford Loop, then repeat Step 1 above.

e. **Make pH or Alkalinity Test.**

After boiler and system have been cleaned and refilled as previously described, test the pH of the water in the system. This can easily be done by drawing a small sample of boiler water and testing with hydrion paper which is used in the same manner as litmus paper, except it gives specific readings. A color chart on the side of the small hydrion dispenser gives the reading in pH. Hydrion paper is inexpensive and obtainable from any chemical supply house or through your local druggist. The pH should be higher than 7, but lower than 11. Add some of the washout chemical (caustic soda), if necessary, to bring the pH within the specified range.

f. Boiler is now ready to be put into service.

C. EXCESSIVE MAKE-UP WATER

IMPORTANT

IF, DURING NORMAL OPERATION, IT IS NECESSARY TO ADD MORE WATER THAN INDICATED BELOW, CONSULT A QUALIFIED SERVICE TECHNICIAN TO CHECK YOUR SYSTEM FOR LEAKS.

EXCESSIVE WATER ADDITION: (Gallons / Month)

MST288: 0.5	MST396: 0.7
MST513: 0.8	MST629: 1.0

A leaky system will increase the volume of make-up water supplied to the boiler, which can significantly shorten the life of the boiler. Entrained in make-up water are dissolved minerals, salts and oxygen. When the fresh, cool make-up water is heated in the boiler, the minerals fall out as sediment, the salts coat the inside of the boiler, and the oxygen escapes as a gas. The accumulation of sediment eventually isolates the water from contacting the cast iron. When this happens the

cast iron in that area gets extremely hot and eventually cracks. The presence of free oxygen or chloride salts in the boiler corrodes the cast iron from the inside. More make-up water and higher concentrations of contaminants damage the boiler sooner. **Our warranty does not cover oxygen corrosion and sediment-related damage.** Clearly it is in everyone's best interest to prevent this type of failure. You can do your part by ensuring that your system is leak-free.

D. ATTENTION TO BOILER WHILE NOT IN OPERATION.

NOTICE

If boiler is not used during winter time, it must be fully drained to prevent freeze damage.

1. Spray inside surfaces with light lubricating or crankcase oil using gun with extended stem so as to reach all corners.
2. With steam boilers, at end of season add sufficient water to fill boiler to top of water column and leave it that way until fall when water should be drained again to proper level. If at this time boiler water is dirty, drain water, flush out boiler, and refill with clean water to prescribed water level.
3. Always keep the manual fuel supply valve shut off if the burner is shut down for an extended period of time.
4. To recondition the heating system in the fall season after a prolonged shut down, follow the instructions outlined in Section VIII, Paragraphs A through J.

WARNING

This boiler contains controls which may cause the boiler to shut down and not restart without service. If damage due to frozen pipes is a possibility, the heating system should not be left unattended in cold weather; or appropriate safeguards and alarms should be installed on the heating system to prevent damage if the boiler is inoperative.

SECTION X: BOILER CLEANING

WARNING

All boiler cleaning must be completed with burner service switch turned off. Boilers equipped with burner swing door have a potential hazard which can cause severe property damage, personal injury or loss of life if ignored. Before opening swing door, turn off service switch to boiler to prevent accidental firing of burner outside the combustion chamber. Disconnect the burner plug from the receptacle in the front jacket. Be sure to tighten swing door fastener completely when service is completed.

A. CLEAN THE FLUEWAYS (See Figure 27).

1. For access to the combustion chamber remove the two (2) 3/8" - 16 cap screws. If boiler is equipped with flexible fuel line(s), swing door open.
2. Remove the two smoke box clean-out covers from the rear smoke box by removing the four 5/16"-18 hex head bolts. It is NOT necessary to remove the vent connector from the smoke box to clean boiler. If necessary, remove the vent connector if there is evidence of heavy soot accumulation in the boiler or to inspect base of chimney for condensate or accumulation of debris.
3. Remove the baffles (if installed) from the flue passages. There is a pair of baffles in each boiler. The baffles are installed in the 2nd pass (two inner flue ways) on the MST396, MST513 and MST629.
4. Clean the 3rd Pass – Insert a 2" dia. x 42" long wire or fiber bristle brush into each of the two 3rd passes. Using long strokes push the brush all the way through the boiler until the brush has exited the smoke box opening. Pull the brush all the way forward until it has exited the front of the boiler. Continue this operation for the entire height of the flue way until clean. Repeat the operation for the other 3rd pass flue way.
5. Clean the 2nd Pass - Insert a 2" dia. x 42" long wire or fiber bristle brush into each of the two 2nd passes. Using long strokes push the brush all the way through the boiler until the brush hits the back wall of the reversing chamber. Pull the brush all the way forward until it has exited the front of the boiler. Continue this operation for the entire height of the flue way until clean. Repeat the operation for the other 2nd pass flue way.
6. Vacuum the loose debris in the bottom of the combustion chamber and smoke box.

B. CLEAN THE COMBUSTION CHAMBER

– Use a wire or fiber bristle brush to clean the surfaces of the combustion chamber. Vacuum all of the loose debris in the bottom of the combustion chamber.

- C. AFTER CLEANING, vacuum all remaining debris as necessary. Inspect burner swing door insulation, and rope gasket for signs of damage. If damaged, replace as needed.

D. REASSEMBLE BOILER.

CAUTION

Do not start the burner unless the burner swing door and canopy cover plates are secured in place.

1. Insert the baffles (if originally installed) into the correct flue way. The baffles are installed in the 2nd pass (two inner flue ways) on the MST396, MST513 and MST629.
2. Attach the smoke box clean-out covers onto the rear of the boiler. Verify that the rope gasket is in good working order before assembly. Replace rope gasket if necessary. Use the 3/8" hardware originally removed. Do not over tighten. They should be snug but not bottomed out.

NOTICE

When securing burner swing door make sure door is drawn-in equally on both sides.

Tighten swing door hardware to provide adequate seal to rope gasket around perimeter of door.

Use an alternating tightening method from right side to left side cap screw to pull door tight equally.

NOTICE

Do not overtighten. The rope gasket will provide sufficient seal when the door is snugged into place.

SECTION X: BOILER CLEANING (continued)

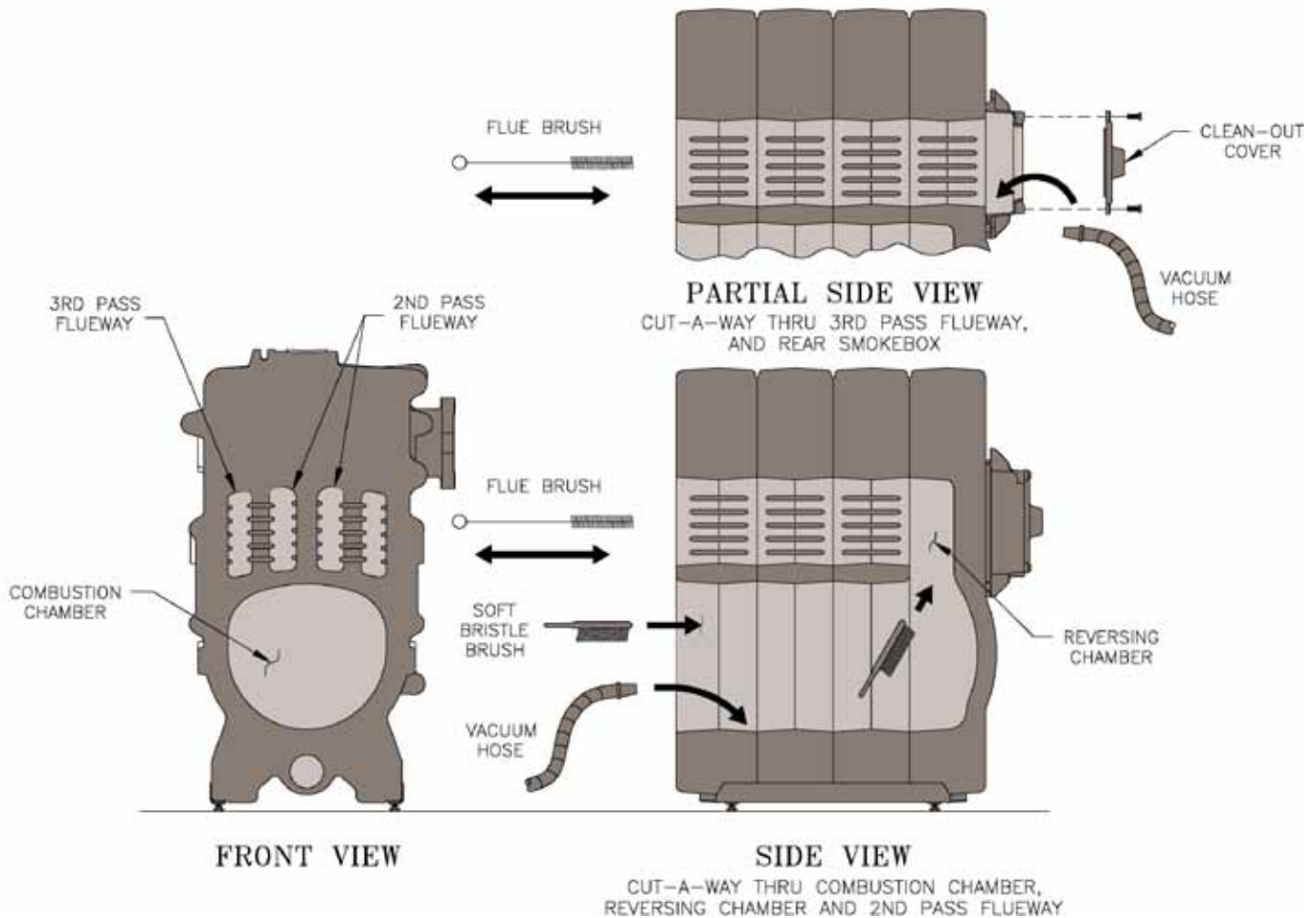

Figure 27: Cleaning Boiler Flueways and Combustion Chamber Surfaces

WARNING

The boiler must be connected to an approved chimney in good condition. Serious property damage could result if the boiler is connected to a dirty or inadequate chimney. The interior of the chimney flue must be inspected and cleaned before the start of the heating season and should be inspected periodically throughout the heating season for any obstructions. A clean and unobstructed chimney flue is necessary to allow noxious fumes that could cause injury or loss of life to vent safely and will contribute toward maintaining the boiler's efficiency.

SECTION XI: TROUBLE SHOOTING

A. COMBUSTION

1. **NOZZLES** — Although the nozzle is a relatively inexpensive device, its function is critical to the successful operation of the oil burner. The selection of the nozzle supplied with the MegaSteam™ boiler is the result of extensive testing to obtain the best flame shape and efficient combustion. Other brands of the same spray angle and spray pattern may be used but may not perform at the expected level of CO₂ and smoke. Nozzles are delicate and should be protected from dirt and abuse. Nozzles are mass-produced and can vary from sample to sample. For all of those reasons a spare nozzle is a desirable item for a serviceman to have.
2. **FLAME SHAPE** — Looking into the combustion chamber through the observation port, the flame should appear straight with no sparklers rolling up toward the crown of the chamber. If the flame drags to the right or left, sends sparklers upward or makes wet spots on the chamber walls, the nozzle should be replaced. If the condition persists look for fuel leaks, air leaks, water or dirt in the fuel as described above.
3. **FUEL LEAKS** — Any fuel leak between the pump and the nozzle will be detrimental to good combustion results. Look for wet surfaces in the air tube, under the ignitor, and around the air inlet. Any such leaks should be repaired as they may cause erratic burning of the fuel and in the extreme case may become a fire hazard.
4. **AIR LEAKS** — Any such leaks should be repaired, as they may cause erratic burning of the fuel and in extreme cases may become a fire hazard.
5. **GASKET LEAKS** — If 11.5 to 12.5% CO₂ with a #1 smoke cannot be obtained in the breeching, look for air leaks around the burner mounting gasket, observation door, and canopy gasket. Such air leaks will cause a lower CO₂ reading in the breeching. The smaller the firing rate the greater effect an air leak can have on CO₂ readings.
6. **DIRT** — A fuel filter is a good investment. Accidental accumulation of dirt in the fuel system can clog the nozzle or nozzle strainer and produce a poor spray pattern from the nozzle. The smaller the firing rate, the smaller the slots become in the nozzle and the more prone to plugging it becomes with the same amount of dirt.
7. **WATER** — Water in the fuel in large amounts will stall the fuel pump. Water in the fuel in smaller amounts will cause excessive wear on the pump, but more importantly water doesn't burn. It chills the flame and causes smoke and unburned fuel to pass out of the combustion chamber and clog the flueways of the boiler.
8. **COLD OIL** — If the oil temperature approaching the fuel pump is 40°F or lower, poor combustion or delayed ignition may result. Cold oil is harder to atomize at the nozzle. Thus, the spray droplets get larger and the flame shape gets longer. An outside fuel tank that is above grade or has fuel lines in a shallow bury is a good candidate for cold oil. The best solution is to bury the tank and lines deep enough to keep the oil above 40°F.
9. **HIGH ALTITUDE INSTALLATIONS** — Air openings must be increased at higher altitudes. Use instruments and set for 11.5 to 12.5% CO₂.
10. **START-UP NOISE** — Late ignition is the cause of start-up noises. If it occurs recheck for electrode settings, flame shape, air or water in the fuel lines.
11. **SHUT DOWN NOISE** — If the flame runs out of air before it runs out of fuel, an after burn with noise may occur. That may be the result of a faulty cut-off valve in the fuel pump, or it may be air trapped in the nozzle line. It may take several firing cycles for that air to be fully vented through the nozzle. Water in the fuel or poor flame shape can also cause shut down noises.

NOTICE

CHECK TEST PROCEDURE. A very good test for isolating fuel side problems is to disconnect the fuel system and with a 24" length of tubing, fire out of an auxiliary five gallon pail of clean, fresh, warm #2 oil from another source. If the burner runs successfully when drawing out of the auxiliary pail then the problem is isolated to the fuel or fuel lines being used on the jobsite.

B. OIL PRIMARY CONTROL

1. Burner (control) will not come on.
 - a. No power to control.
 - b. Control is in lockout or restricted mode. Press reset button for one (1) second to exit lockout. If control has recycled three times within the same call for heat, it will enter into restricted mode. To reset from restricted mode, refer to Section VIII, Paragraph I, No. 2 for details.
 - c. CAD cell seeing light.
 - d. CAD assembly defective.
 - e. Control motor relay is stuck closed (see note below).
2. Burner (control) will light, then shut down after a short time, then restart after one (1) minute.
 - a. CAD cell is defective.
 - b. Air leaking into oil line causing flame out.
 - c. Defective nozzle causing flame to be erratic.

SECTION XI: TROUBLE SHOOTING (continued)

- d. Excessive airflow or draft causing flame to leave burner head.
 - e. Excessive back pressure causing flame to be erratic.
3. Control locks out after Trial For Ignition (TFI).
- a. No oil to burner.
 - b. Shorted electrodes.
 - c. Nozzle clogged.
 - d. Airflow too high.
 - e. Ignitor module defective.
 - f. CAD cell defective.
 - g. Oil valve stuck open or closed.

Note: The Safety Monitoring Circuit (SMC) is designed to provide lockout in the event of a stuck or welded motor relay.

NOTICE

If flame is not established within 15 seconds of oil valve actuation (known as Trial For Ignition [TFI]) lockout will occur. Lockout is indicated by a red LED solid-on located on the oil primary control.

Latch-up will occur if the control locks-out three (3) times during a call for heat. This is indicated by steady-on red and amber LED's.

Not Applicable to Riello 40 Series Burner, refer to *Models F3 and F5 Installation Manual, Riello 40 Series Residential Oil Burners (C6501010)*.

SECTION XII: REPAIR PARTS

All MegaSteam™ Boiler Repair Parts may be obtained through your local U.S. Boiler Company Wholesale distributor. Should you require assistance in locating a U.S. Boiler Company Distributor in your area, or have questions regarding the availability of U.S. Boiler Company products or repair parts, please contact U.S. Boiler Company Customer Service at (717) 481-8400 or Fax (717) 481-8408.

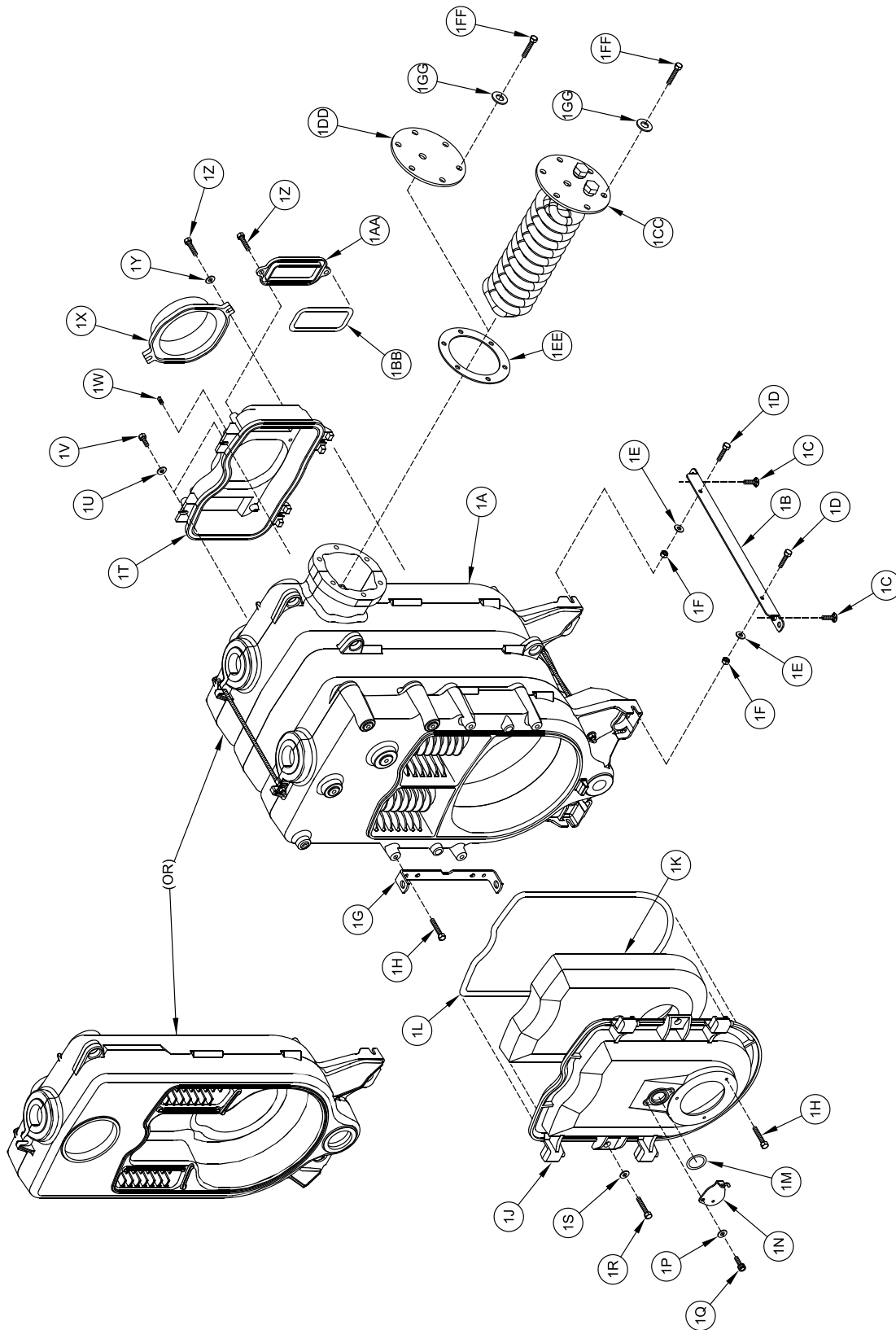

Bare Boiler Assembly

SECTION XII: REPAIR PARTS (continued)

Item No.	Description	Part No.	MST288	MST396	MST513	MST629	
1. BARE BOILER ASSEMBLY							
1A	Cast Iron Block Assembly - 3 Section (Non Heater)	100567-03	1	1	---	---	
	Cast Iron Block Assembly - 3 Section (Heater)	100566-03	1	1	---	---	
	Cast Iron Block Assembly - 4 Section (Non Heater)	100567-04	---	---	1	---	
	Cast Iron Block Assembly - 4 Section (Heater)	100566-04	---	---	1	---	
	Cast Iron Block Assembly - 5 Section (Non Heater)	100567-05	---	---	---	1	
	Cast Iron Block Assembly - 5 Section (Heater)	100566-05	---	---	---	1	
1B	Spanner Bar w/Threaded Inserts, 1-1/4" x 1-1/2" x 20-3/8" Lg.	100012-02	2	2	---	---	
	Spanner Bar w/Threaded Inserts, 1-1/4" x 1-1/2" x 26-3/8" Lg.	100012-03	---	---	2	---	
	Spanner Bar w/Threaded Inserts, 1-1/4" x 1-1/2" x 32-3/8" Lg.	100012-04	---	---	---	2	
1C	Carriage Bolt, 3/8" -16 x 1-1/4" Lg., Plated	100215-01	4	4	4	4	
1D	Cap Screw, 5/16" -18 x 7/8" Lg., Plated	80861371	4	4	4	4	
1E	Flat Washer, 5/16", USS, Plated	80860611	4	4	4	4	
1F	Hex Nut, 5/16 -18, Serrated Flange, Plated	80860443	4	4	4	4	
1G	Hinge Bracket	100014-01	1	1	1	1	
1H	5/16" -18 x 3/4" Lg. Cap Screw, Plated	Hinge Bracket	80861340	2	2	2	2
		Mount Burner		3	3	3	3
1J	Cast Iron Burner Swing Door (Only)	100071-01	1	1	1	1	

SECTION XII: REPAIR PARTS (continued)

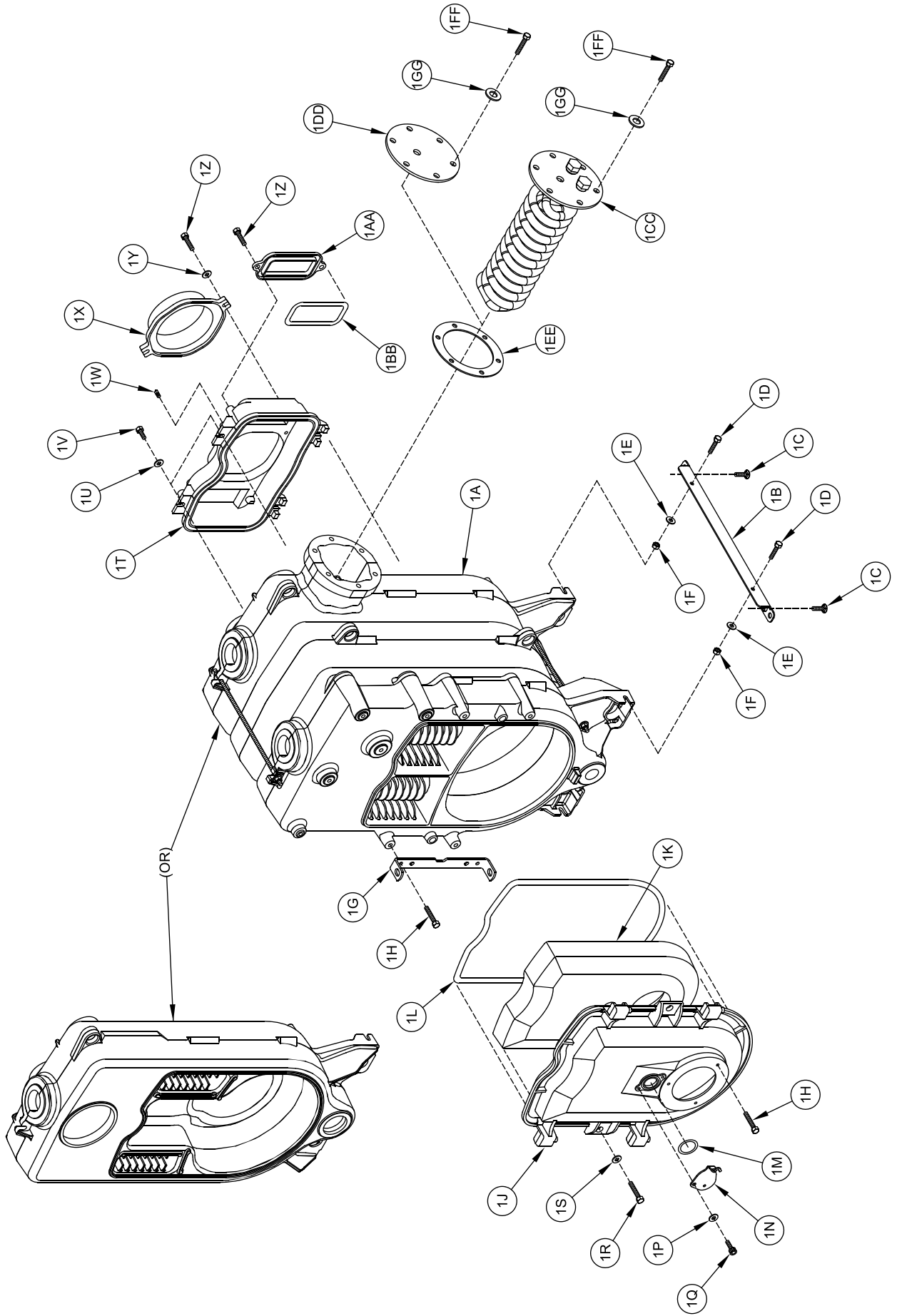

Bare Boiler Assembly

SECTION XII: REPAIR PARTS (continued)

Item No.	Description	Part No.	MST288	MST396	MST513	MST629	
1. BARE BOILER ASSEMBLY (Continued)							
1K	Burner Swing Door Insulation (Less Pockets)	100039-01	1	1	1	---	
	Burner Swing Door Insulation (With Pockets)	100039-02	---	---	---	1	
1L	5/8" Dia. Rope Gasket - Burner Swing Door	100097-01	1	1	1	1	
1M	1/8" Dia. Rope Gasket - Observation Port	100096-01	1	1	1	1	
1N	Observation Port Cover	100015-01	1	1	1	1	
1P	5/16" Flat Washer, SAE, Plated	80860647	2	2	2	2	
1Q	Socket Head Cap Screw, 5/16" x 5/8" Lg., Plated	100050-01	2	2	2	2	
1R	Tap Bolt, 3/8" -16 x 1-3/4" Lg., Plated	100102-01	2	2	2	2	
1S	5/16" Flat Washer, USS, Plated	80860611	2	2	2	2	
1T	Smokebox	100021-01	1	1	1	1	
1U	5/16" Flat Washer, USS, Plated	80860611	4	4	4	4	
1V	Cap Screw, 5/16" -18 x 3/4" Lg., Plated	80861340	4	4	4	4	
1W	1/4" NPT Pipe Plug, Square Head, Brass	806603542	1	1	1	1	
1X	Smokebox Collar	6" Dia.	100093-01	1	1	1	---
		7" Dia.	100094-01	---	---	---	1
1Y	5/16" Flat Washer, USS, Plated	80860611	2	2	2	2	
1Z	Cap Screw, 5/16" -18 x 7/8" Lg., Plated	80861371	6	6	6	6	
1AA	Cast Iron Clean-Cut Cover (only)	100104-01	2	2	2	2	
1BB	1/2" Dia. Rope Gasket - Clean-Cut Cover	100095-01	2	2	2	2	
1CC	222A Heater Carton Assembly	6036036	1	1	1	1	
1DD	Tapped Heater Cover Plate - Rear Heater	7036031	1	1	1	1	
1EE	Heater Cover Plate Gasket	8036068	1	1	1	1	
1FF	Cap Screw, 3/8" -16" x 7/8" Lg., Plated, ASME Grade SA307B	80861337	6	6	6	6	
1GG	5/16" Flat Washer, SAE, Plated	80860647	6	6	6	6	

SECTION XII: REPAIR PARTS (continued)

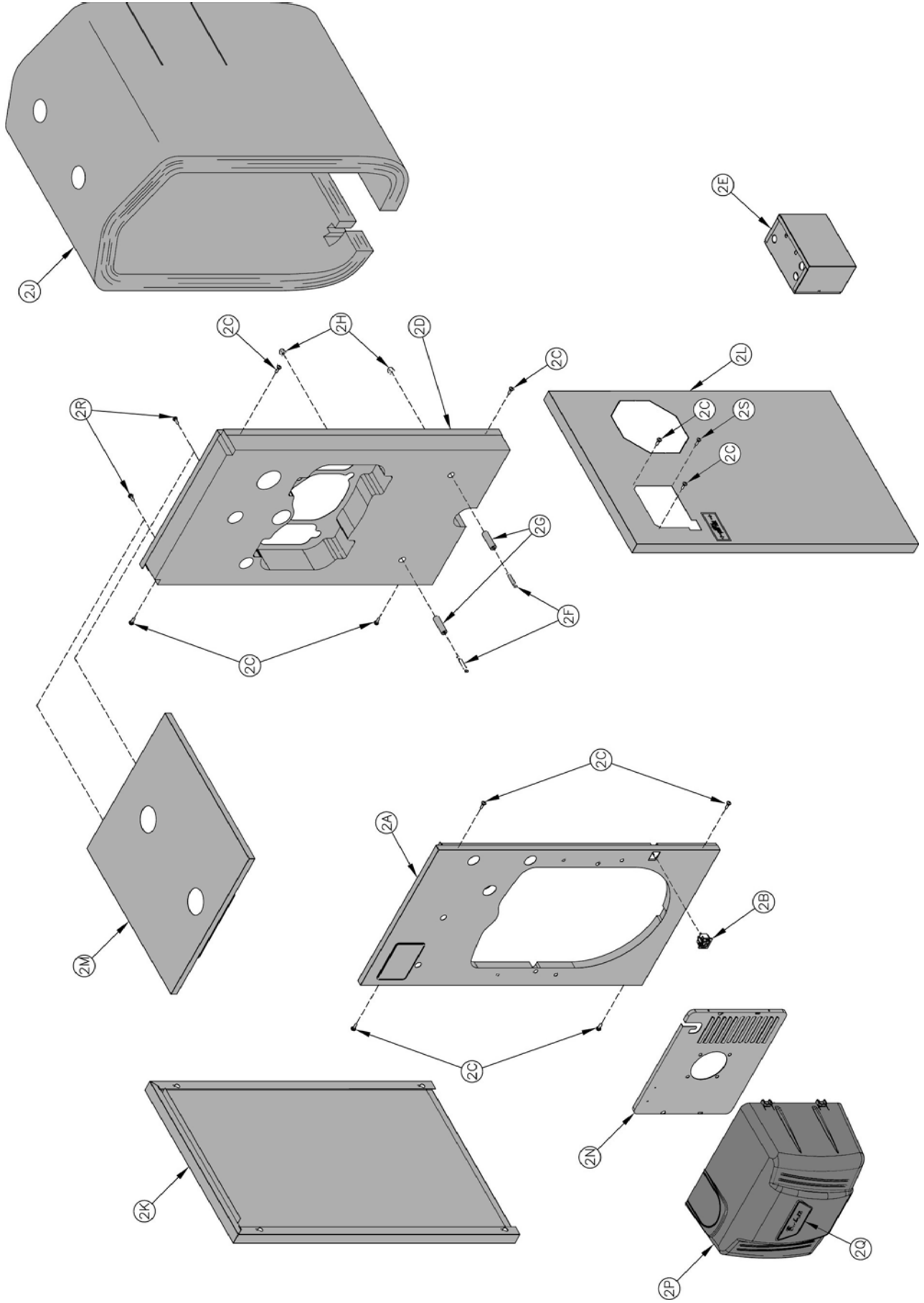

Jacket Assembly

SECTION XII: REPAIR PARTS (continued)

Item No.	Description	Part No.	MST288	MST396	MST513	MST629
2. JACKET ASSEMBLY						
2A	Jacket Front Panel Assembly w/Insulation	100575-01	1	1	1	1
2B	Power Outlet Receptacle, w/Harness	100605-01	1	1	1	1
2C	#8 x 1/2" Type AB Truss Head w/Shoulder, Sheet Metal Screw, Plated	100038-01	10	10	10	10
2D	Jacket Rear Panel Assembly w/Insulation	100578-01	1	1	1	1
2E	External Wiring Enclosure	100602-01	1	1	1	1
2F	Tap End Stud, 5/16" -18 x 3" Lg., Plain	100046-01	2	2	2	2
2G	5/8" O.D. x 2-5/32" Lg. Jacket Spacer	100035-01	2	2	2	2
2H	Acorn Nut, 5/16" -18, Plated	100047-01	2	2	2	2
2J	3" Thick Fiberglass Insulation Wrapper	100614-03	1	1	---	---
		100614-04	---	---	1	---
		100614-05	---	---	---	1
2K	Jacket Left Side Panel - 3 Section	100581-03	1	1	---	---
	Jacket Left Side Panel - 4 Section	100581-04	---	---	1	---
	Jacket Left Side Panel - 5 Section	100581-05	---	---	---	1
2L	Jacket Right Side Panel - 3 Section	100583-03	1	1	---	---
	Jacket Right Side Panel - 4 Section	100583-04	---	---	1	---
	Jacket Right Side Panel - 5 Section	100583-05	---	---	---	1
2M	Jacket Top Panel - 3 Section	100585-03	1	1	---	---
	Jacket Top Panel - 4 Section	100585-04	---	---	1	---
	Jacket Top Panel - 5 Section	100585-05	---	---	---	1
2N	Beckett Burner Plastic Enclosure Backer Plate	102233-01	1	1	1	1
2P	Beckett Burner Plastic Enclosure Cover	102232-01	1	1	1	1
2Q	Beckett Burner Plastic Enclosure Name Plate	102231-01	1	1	1	1
2R	Sheet Metal Screw, Plated, Phillips Truss Head, Type AB, #8 x 1/2" Lg.	80860000	2	2	2	2
2S	Sheet Metal Screw, Plated, Phillips Pan Head, Type B, #8 x 1/2" Lg.	80860019	1	1	1	1

SECTION XII: REPAIR PARTS (continued)

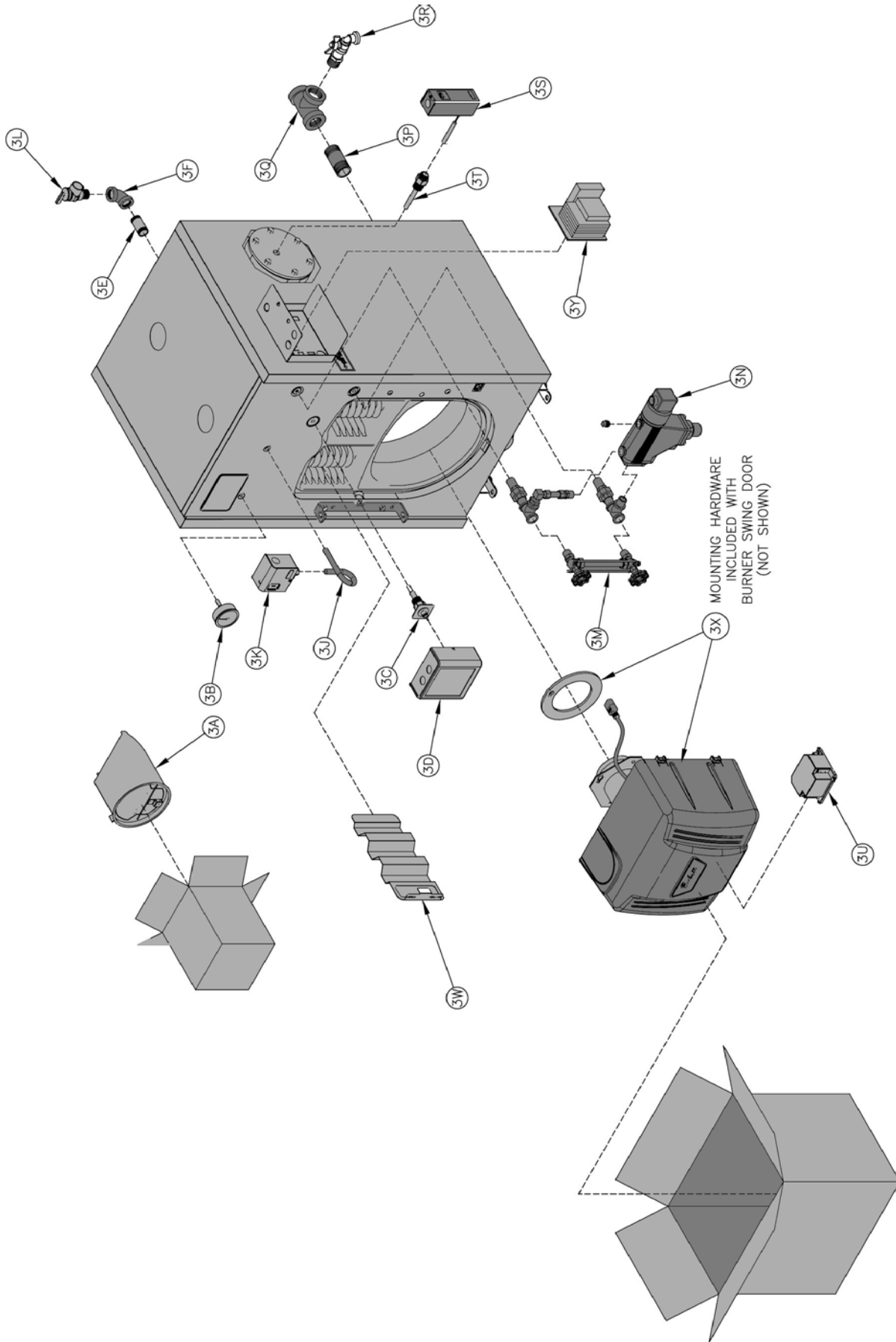

MST288 Thru MST629 Steam Boilers - Trim and Controls

SECTION XII: REPAIR PARTS (continued)

Item No.	Description	Part No.	MST288	MST396	MST513	MST629
3. MST - TRIM AND CONTROLS						
3A	6" RC-STD Draft Regulator	8116288	1	1	1	---
	7" RC-STD Draft Regulator	8116289	---	---	---	1
3B	Pressure Gauge	100325-01	1	1	1	1
3C	Probe, Hydrolevel EL-1214 (for Hydrolevel CG450)	80160629	1	1	1	1
3D	Low Water Cut-off, Hydrolevel CG450 (less Probe)	80160623	1	1	1	1
	Low Water Cut-off, McDonnell & Miller PS-801	80160723				
3E	Nipple, 3/4" NPT x 3" Lg.	806600002	1	1	1	1
3F	Elbow, 3/4" NPT x 90	806601502	1	1	1	1
3J	Syphon, 1/4" NPT x 1-7/8" x 4" x 90	806603010	1	1	1	1
3K	Pressure Limit, Honeywell L404F1367	80160369	1	1	1	1
3L	Safety Valve, 3/4" NPT, 15 PSI, Conbraco 13-511-08	81660530	1	1	1	1
3M	Gauge Glass Set, 6", Conbraco 20-104-10	8056091	1	1	1	1
3N	Low Water Cut-off, McDonnell & Miller 67	80160597	1	1	1	1
3P	Nipple, 1-1/2" NPT x 5" Lg.	808600060	1	1	1	1
3Q	Tee, 1-1/2" x 1-1/2" x 3/4"	806601105	1	1	1	1
3R	Drain Valve, 3/4" NPT, Conbraco 35-302-03	806603061	1	1	1	1
3S	Limit, Honeywell L4006A2015	80160400	1	1	1	1
3T	Well, 1/2" NPT x 3", Honeywell 123872A	80160497	1	1	1	1
3U	Oil Primary Control, Honeywell R7284P1080	103880-01	1	1	1	1
3W	Stainless Steel 2nd Pass Flueway Baffle	100042-01	---	1	1	1
3X	Beckett AFG Oil Burner w/Gasket for:					
	MST288 Spec. No. BCB9006	103895-03	1	---	---	---
	MST396 Spec. No. BCB9003	103892-03	---	1	---	---
	MST513 Spec. No. BCB9004	103893-04	---	---	1	---
	MST629 Spec. No. BCB9005	103894-05	---	---	---	1
(NOTE: See Pages 60 and 61 for burner Parts Breakdown)						
3Y	Fan Center, Honeywell R8285C w/Connectors	100640-01	1	1	1	1

SECTION XII: REPAIR PARTS (continued)

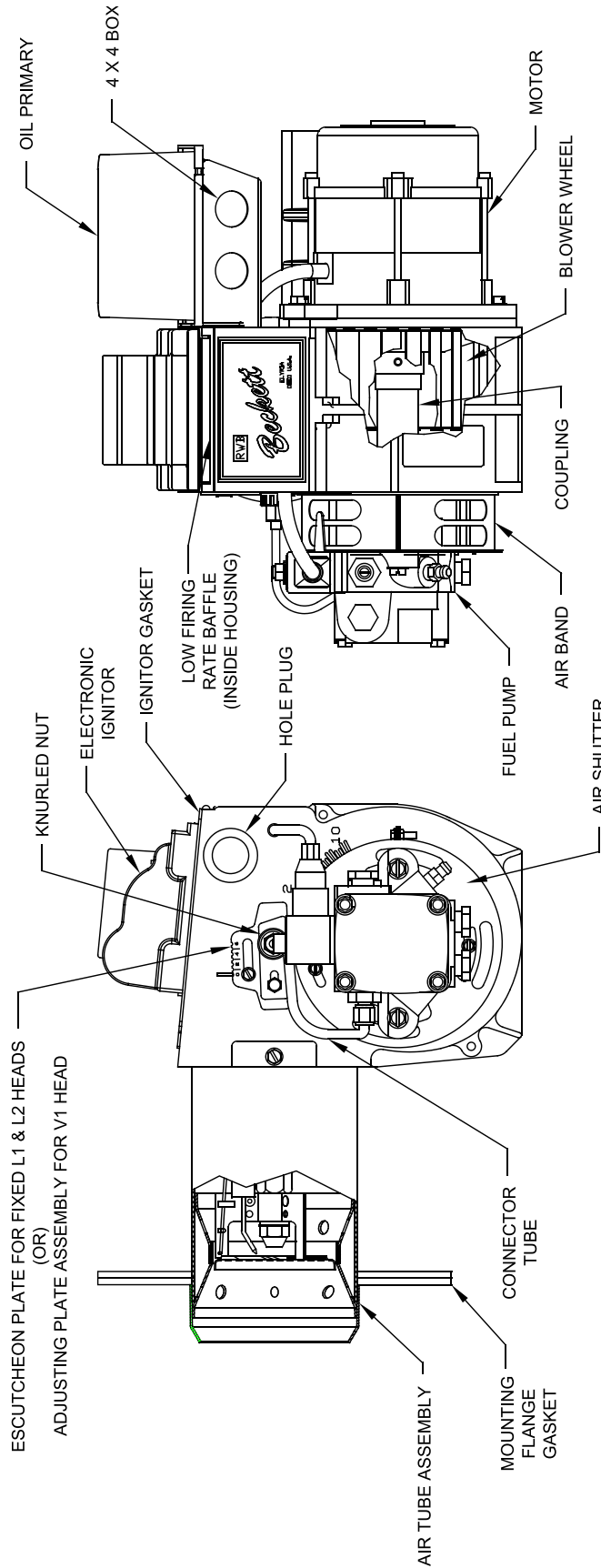

SIDE VIEW

FRONT VIEW

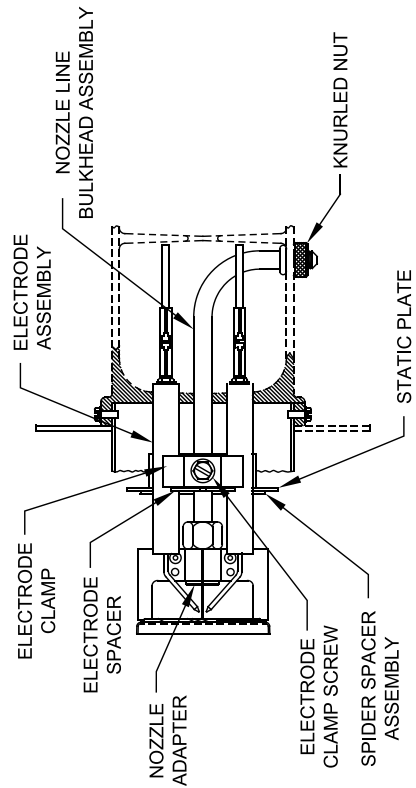

NOZZLE DETAIL

Beckett AFG Burner

SECTION XII: REPAIR PARTS (continued)

BECKETT OIL BURNER PART NOS. FOR MEGASTEAM™ SERIES BOILERS

NOTE: When ordering parts always give the serial and model numbers shown on the boiler and burner. Also provide the name of the part(s) and part number as listed below.

Boiler Model	MST288	MST396	MST513	MST629
Air Tube Combination	AFG70MMAQN	AFG70MMAQN	AFG70MLASN	AFG70MKASN
Beckett's Spec. No.	BCB9006	BCB9003	BCB9004	BCB9005
Air Band	3492	3492	3492	3492
Air Band Nut	4150	4150	4150	4150
Air Band Screw	4198	4198	4198	4198
Air Shutter	3709	3709	3709	3709
Air Shutter Screw	4198	4198	4198	4198
Blower Wheel	2999	2999	2999	2999
Coupling	2454	2454	2454	2454
Low Firing Rate Baffle	Less	Less	Less	Less
Bulkhead Knurled Locknut	3666	3666	3666	3666
Connector Tube Assembly	5636	5636	5636	5636
Electrode Clamp	149	149	149	149
Electrode Clamp Screw	4219	4219	4219	4219
Electrode Insulator Assembly	5780	5780	5780	5780
Support / Spacer Assembly	5992	5992	5992	5992
Escutcheon Plate	---	---	---	---
Adjusting Plate Assembly	5941	5941	5941	5941
Head	5913	5913	5913	5913
Head Screws	4221	4221	4221	4221
Flange Gasket	3811	3811	3811	3811
AFG Housing	5874GY	5874GY	5874GY	5874GY
Motor	21805E/218	21805E/218	21805E/218	21805E/218
Nozzle Adapter	213	213	213	213
Nozzle Line Electrode Assembly	NL70MD	NL70MD	NL70MD	NL70MD
Oil Pump, Clean Cut, Single Stage	21844	21844	21844	21844
Oil Pump, Clean Cut, Two-Stage	21941	21941	21941	21941
Static Plate	3383	3383	3383	3383
Ignitor	51771U	51771U	51771U	51771U
Ignitor Hinge Screw	42176	4217	4217	4217
Ignitor Holding Screw	4292	4292	4292	4292
Ignitor Gasket Kit	51304	51304	51304	51304
Wire Guard	10251	10251	10251	10251
Junction Box	3741	3741	3741	3741
Flame Detector	7006Q	7006Q	7006Q	7006Q
Oil Solenoid Valve Coil	21775U	21775U	21775U	21775U
Oil Solenoid Valve Cord	21807	21807	21807	21807

SECTION XII: REPAIR PARTS (continued)

RIELLO OIL BURNER PART NUMBERS FOR MEGASTEAM 3-PASS OIL BOILERS

NOTE: When ordering parts always give the serial and model numbers shown on the boiler and burner.

Refer to *Models F3 & F5 Installation Manual, Riello 40 Series Residential Oil Burners (C6501010)* for an exploded view of the burner and a list of spare parts.

For replacement Riello oil burner parts, contact your wholesaler or the burner manufacturer:

Riello Corporation of America
35 Pond Park Road
Hingham, Massachusetts 02043
Telephone: (617) 749-8292
Facsimile: (617) 740-2069
Toll Free: (outside Massachusetts)
(800) 992-7637

Riello Canada Inc.
2165 Meadowpine Blvd.
Mississauga, Ontario L5N 6H6
Telephone: (905) 542-0303
Facsimile: (905) 542-1525
Toll Free: (800) 387-3898

CARLIN OIL BURNER PART NUMBERS FOR MEGASTEAM SERIES BOILERS

NOTE: When ordering parts always give the serial and model numbers shown on the boiler and burner.

Refer to *Installation and Operating Instructions for Packaged Heating/Burner Units, Carlin Elite EZ-LF and EZ-66 Oil Burners (Form CCT-569A)* for an exploded view of the burner and a list of spare parts.

For replacement Carlin oil burner parts, contact your wholesaler or the burner manufacturer:

CCT, Carlin Combustion Technology, Inc.
70 Maple Street
East Longmeadow, MA 01028
Telephone: (413) 525-7700
Facsimile: (413) 525-8306

SECTION XII: REPAIR PARTS (continued)

TABLE 7: BECKETT AFG BURNER SPECIFICATIONS

Boiler Model	Burner Input (gph)	Head Type (setting)	Air Shutter (setting)	Air Band (setting)	Nozzle	Pump Pressure (psi)	Approx. Shipped CO ₂ (%)	Baffle Location (pass)	Approx. Stack Temp. Increase Without Baffles (F) ²	Baffles IN Minimum Breach Pressure ("w.c.) ³	Baffles OUT Minimum Breach Pressure ("w.c.) ³	Baffles IN Minimum Overfire Pressure ("w.c.) ³	Baffles OUT Minimum Overfire Pressure ("w.c.) ³
MST288	0.75	L1	6'	1	0.60 x 60A Delavan	150	11.5	---	---	0	0	---	0.010
MST396	1.05	L1	7	1	0.85 x 60B Delavan	150	11.5	2nd	20	0	0	0.040	0.020
MST513	1.35	V1 (0)	7	2	1.10 x 60B Hago	150	11.5	2nd	40	0	0	0.040	0.030
MST629	1.65	V1 (3)	7	2	1.35 x 60B Hago	150	11.5	2nd	52	0	0	0.050	0.030

Notes

- 1) MST288 at 0.75 GPH firing rate utilizes a low fire baffle.
- 2) The increased stack temperature with the baffles removed is an approximation, based on a constant supply temperature of 212°F and 11.5% CO₂. Actual field conditions may be different.
- 3) These values are minimum and could be as much as -.03" w.c., more without impacting performance. Pressures based on 11.5% CO₂. Example: MST629 could have a breach pressure of -.03" w.c. and an overfire pressure of .020" w.c.
- 4) Single stage fuel pump is standard, two stage fuel pump is optional. Burner manufacturer has preset single stage fuel pump to settings shown in table above. Two stage fuel pump is factory set at 140 PSI and must be readjusted to settings shown above during burner start-up.

TABLE 7A: RIELLO BURNER SPECIFICATIONS

Boiler Model	Burner Model	Burner Input (GPH)	Nozzle	Air Gate (setting)	Turbulator (setting)	Pump Pressure (PSI)	Combustion Head	Insertion Depth (Inch)	Approx. Shipping CO ₂ (%)	Baffle Location (Pass)	Approx. Stack Temp Increase without Baffles (°F) ⁽¹⁾	Baffles IN Min. Breach Pressure ("w.c.) ⁽²⁾	Baffles OUT Min. Breach Pressure ("w.c.) ⁽²⁾	Baffles IN Min. Overfire Pressure ("w.c.) ⁽²⁾	Baffles OUT Min. Overfire Pressure ("w.c.) ⁽²⁾
MST396	F5	1.05	0.85 x 60°B Delavan	2.7	1.0	145	LBT 10.0"	10.0	11.5	2nd	65	0	0	0.040	0.020
MST513	F5	1.35	1.10 x 60°B Delavan	4.5	3.0	150	SBT 6"	3.5	11.5	2nd	39	0	0	0.040	0.030
MST629	F5	1.65	1.35 x 60°B Delavan	3.5	4.0	145	VSBT	2.25	11.5	2nd	18	0	0	0.050	0.030

¹ The increased stack temperature with the baffles removed is an approximation based on a constant supply temperature of 180°F and 11.5% CO₂. Actual field conditions may be different.

² These values are minimum and could be as much as -.03" w.c., more without impacting performance. Pressures based on 11.5% CO₂. Example: MST629 could have a breach pressure of -.03" w.c. and an overfire pressure of .020" w.c.

SECTION XII: REPAIR PARTS (continued)

TABLE 7B: CARLIN BURNER SPECIFICATIONS

Boiler Model	Burner Input (GPH)	Burner Model	Nozzle	Head Setting	Air Setting	Pump Pressure (PSI)	Air Tube Type	Insertion Depth (Inch)	Approx. Shipped CO ₂ (%)	Baffle Location (pass)	Approx. Stack Temp. Increase Without Baffles °F (2)	Approx. Breech Pressure (" w.c.) (3)	Baffles IN Approx. Overfire Pressure (" w.c.) (3)	Baffles OUT Approx. Overfire Pressure (" w.c.) (3)
MST396	1.05	EZ-66	0.85 x 45AS Dantfoss	2.0	40	150	Conical Wrap	2-5/8	11.5	2 nd	65	0	+0.040	+0.020
MST513	1.35	EZ-66	1.10 x 45B Delavan	3.5	50	150	Conical Wrap	2-5/8	11.5	2 nd	39	0	+0.040	+0.030
MST629	1.65	EZ-66	1.35 x 45B Hago	5.5	60	150	Conical Wrap	2-5/8	11.5	2 nd	18	0	+0.050	+0.030

Notes

(2) The increased stack temperature with the baffles removed is an approximation, based on a constant supply temperature of 160°F and 11.5% CO₂. Actual field conditions may be different.

(3) These values are minimum and could be as much as -.03" w.c., more without impacting performance. Pressures based on 11.5% CO₂. Example: MST629 could have a breech pressure of -.03" w.c. and an overfire pressure of .020" w.c.

4) Single stage fuel pump is standard, two-stage fuel pump is optional. Burner manufacturer has preset single stage fuel pump to settings shown in table above. Two-stage fuel pump is factory set at 140 PSI and must be readjusted to settings shown above during burner start-up.

APPENDIX A - FIGURES

Figure Number	Page Number	Description
Figure 1	5	MST288 Thru MST629 Steam Boiler with and without Tankless Heater (Beckett Burner Shown)
Section I - Pre-Installation		
Figure 2	7	Minimum Installation Clearances to Combustible Materials (Inches)
Section II - Unit-Pak Boiler Assembly		
Figure 3	9	MegaSteam Unit-Pak Boiler Shipment Contents (outside container removed)
Figure 4	11	Boiler Removal from Skid
Figure 5A	12	Partial Front View - Burner Swing Door Mounted to Boiler - Fully Closed and Secured
Figure 5B	13	Top View - Burner Swing Door Mounted to Cast Iron Block Assembly (Jacket Removed for Clarity)
Figure 5C	14	Top View - Burner Swing Door Fully Closed but Not Properly Secured or Sealed
Figure 6	15	Flueway Baffle Positioning/Orientation in Flueways
Figure 7	16	Purpose of Tappings and Bosses
Figure 8	18	Pressure Limit Installation
Figure 9	19	Float-Type LWCO and Pressure Limit Installation
Figure 10	21	Oil Burner Installation (Beckett Burner Shown)
Figure 11A	22	Installation/Removal of Drawer Assembly
Figure 11B	22	Nozzle Replacement
Figure 11C	22	Electrode Setting
Figure 11D	23	Turbulator Setting
Figure 11E	23	Pump Connections and Port Identification
Section III - Steam Boiler Piping & Trim		
Figure 12	25	Recommended Boiler Piping for Gravity Return Steam Boiler
Section IV - Tankless & Indirect Water Heater Piping		
Figure 13	27	Schematic Tankless Water Heater Piping
Figure 14	28	Alliance SL Water Heater Piping with MegaSteam Boiler
Section V - Venting & Air Intake Piping		
Figure 15	30	Recommended Vent Pipe Arrangement and Chimney Requirements
Figure 16	30	Proper and Improper Locations of Draft Regulator
Figure 17	31	Smokebox Pressure Tapping for Checking Draft at Breech
Section VI - Electrical		
Figure 18	34	Wiring Diagram, Hydrolevel CG450 Probe LWCO
Figure 18A	35	Wiring Diagram, McDonnell & Miller PS-801 Probe LWCO
Figure 18B	36	Wiring Diagram, McDonnell & Miller #67 Float LWCO
Figure 19	37	Wiring Diagram, Wiring Diagram, All Burner Options with Various Oil Primary Controls
Section VII - Oil Piping		
Figure 21	39	Single Pipe Oil Line
Figure 22	40	Two Pipe Oil Lines

APPENDIX A - FIGURES (continued)

Figure Number	Page Number	Description
Section VIII - System Start-Up		
Figure 23	42	Adjusting Fuel Pump Pressure
Figure 24	43	"L1" and "V1" Head Electrode Positioning and Gun Setting (Beckett AFG)
Figure 25	44	R7284 Oil Primary Terminals, Display and Function Buttons
Figure 26	45	Cad Cell Location
Section X - Boiler Cleaning		
Figure 27	51	Cleaning Boiler Flueways and Combustion Chamber Surfaces
Section XII - Repair Parts		
N/A	Pages 54 thru 62	

APPENDIX B - TABLES

Table Number	Page Number	Description
Table 1A	<u>6</u>	Dimensional Data (See Figure 1)
Table 1B	6	Rating Data
Section II - Unit-Pak Boiler Assembly		
Table 2	14	Baffle Usage
Table 3	16	Purpose of Tappings and Bosses
Section IV - Tankless & Indirect Water Heater Piping		
Table 4	27	Tankless Heater Data
Section VII - Oil Piping		
Table 5	40	Two-Stage Units (3450 RPM) - Two Pipe Systems
Table 6	40	Single-Stage Units (3450 RPM) - Two Pipe Systems
Section XII - Repair Parts		
Table 7	65	Beckett AFG Burner Specifications
Table 7A	65	Riello Burner Specifications
Table 7B	66	Carlin Burner Specifications
N/A	Pages 55 thru 63	

U.S. Boiler Company, Inc.
P.O. Box 3020
Lancaster, PA 17604
1-888-432-8887
www.usboiler.net