

Job Name:	
System Reference:	Date:



Indoor Unit: MSZ-GL15NA-U1



Wireless Remote Controller

SPECIFICATIONS:

Rated Capacity*		
Cooling ¹	Btu/h / W	14,000
Heating at 47° F ²	Btu/h / W	18,000

Rating Conditions per AHRI Standard:

¹ Cooling | Indoor: 80° F (27° C)DB / 67° F (19° C)WB; Outdoor: 95° F (35° C)DB / 75° F (24° C)WB

² Heating at 47°F | Indoor: 70° F (21° C)DB / 60° F (16° C)WB; Outdoor: 47° F (8° C)DB / 43° F (6° C)WB

For data on specific indoor units (all ducted, all non-ducted, and both ducted and non-ducted) combinations, see the MXZ Technical and Service Manual.

Applications should be restricted to comfort cooling only; equipment cooling applications are not recommended for low ambient temperature conditions.

ACCESSORIES:

Indoor Unit

- Condensate Pump (BlueDiamond X87-711/721; 115/230V)
- Condensate Pump (Sauermann SI30-115/230; 115/230V)
- Anti-Allergy Enzyme Filter (MAC-408FT-E)
- Platinum Catalyst Deodorizing Filter (MAC-308FT-E)
- Drain Pan Level Sensor (DPLS2)

Controls

- Wireless Controller (MHK1)
- Wired Remote Controller PAR-31MAA (Requires MAC-333IF-E)
- Wireless Interface for kumo cloud™ (PAC-WHS01WF-E)
- Thermostat Interface (PAC-US444CN-1)

Electrical Power Requirements		208 / 230V, 1-Phase, 60 Hz	
Minimum Circuit Ampacity (MCA)	A	1	
Blower Motor (ECM)	F.L.A.	0.76	
Blower Motor Output	W	30	
Field Drainpipe Size O.D.	In.(mm)	5/8 (15)	
Airflow Rate (Quiet - Lo - Med - Hi - Super Hi)			
Cooling	DRY	CFM	205-272-335-420-533
	WET		170-237-300-385-498
Heating	DRY		205-247-304-367-463
Sound Pressure Level (Quiet - Lo - Med - Hi - Super Hi)			
Cooling	dB(A)	26-32-38-44-49	
Heating		26-30-35-40-46	
External Dimensions (H x W x D)	In.(mm)	11-5/8 x 31-7/16 x 9-1/8 (295 x 798 x 232)	
Net Weight	Lbs.(kg)	22 (10)	
External Finish	Munsell 1.0Y 9.2 / 0.2		
Refrigerant Piping (Flared)			
Liquid (High Pressure)	In.(mm)	1/4 (6.35)	
Gas (Low Pressure)		1/2 (12.7)	

DIMENSIONS: MSZ-GL15NA-U1

MSZ-GL15NA-U1

Unit: in. (mm)

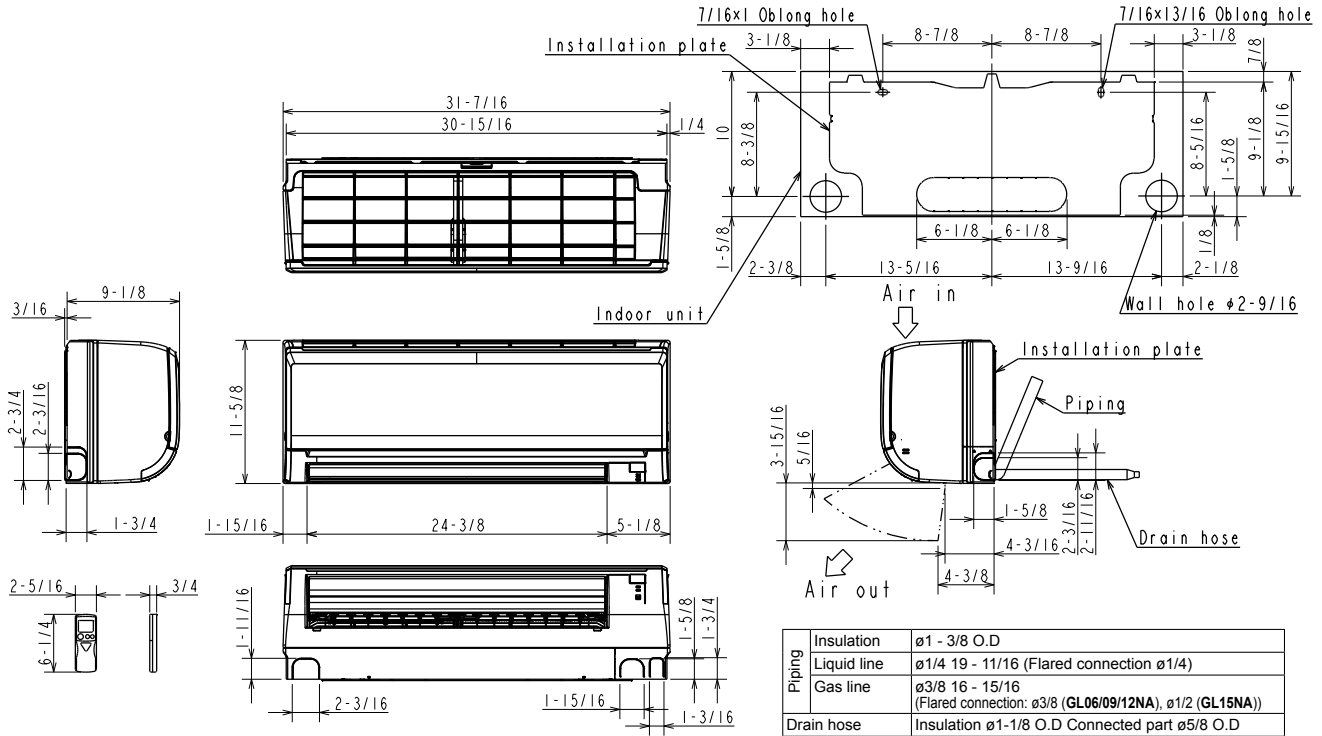

COOLING & HEATING

1340 Satellite Boulevard, Suwanee, GA 30024
Toll Free: 800-433-4822 www.mehvac.com

