

Job Name:	Date:
System Reference:	



Indoor Unit: MSZ-FH15NA



Wireless Remote Controller

### SPECIFICATIONS:

Rated Capacity*		
Cooling <sup>1</sup>	Btu/h / W	15,000
Heating at 47° F <sup>2</sup>	Btu/h / W	18,000

Rating Conditions per AHRI Standard:

<sup>1</sup> Cooling | Indoor: 80° F (27° C)DB / 67° F (19° C)WB; Outdoor: 95° F (35° C)DB / 75° F (24° C)WB

<sup>2</sup> Heating at 47° F | Indoor: 70° F (21° C)DB / 60° F (16° C)WB; Outdoor: 47° F (8° C)DB / 43° F (6° C)WB

For data on specific indoor units (all ducted, all non-ducted, and both ducted and non-ducted) combinations, see the MXZ Technical and Service Manual.

Applications should be restricted to comfort cooling only; equipment cooling applications are not recommended for low ambient temperature conditions.

Electrical Power Requirements	208 / 230V, 1-Phase, 60 Hz	
-------------------------------	----------------------------	--

Minimum Circuit Ampacity (MCA)	A	1
--------------------------------	---	---

Blower Motor (ECM)	F.L.A.	0.67
--------------------	--------	------

Blower Motor Output	W	30
---------------------	---	----

Field Drainpipe Size O.D.	In.(mm)	5/8 (15)
---------------------------	---------	----------

Airflow Rate (Lo - Med - Hi - Super Hi - Powerful)			
Cooling	DRY	CFM	225-262-304-355-411
	WET		194-225-261-305-354
Heating	DRY		201-254-317-394-497

Sound Pressure Level (Lo - Med - Hi - Super Hi - Powerful)		
Cooling	dB(A)	27-31-35-39-44
Heating		25-29-34-39-46

External Dimensions (H x W x D)	In.(mm)	12 + 11/16 x 36-7/16 x 9-3/16 (305 +17 x 925 x 234)
---------------------------------	---------	---

Net Weight	Lbs.(kg)	29 (12)
------------	----------	---------

External Finish	Munsell 1.0Y 9.2 / 0.2	
-----------------	------------------------	--

Refrigerant Piping (Flared)		
Liquid (High Pressure)	In.(mm)	1/4 (6.35)
Gas (Low Pressure)		1/2 (12.7)

### ACCESSORIES:

#### Indoor Unit

- Condensate Pump (BlueDiamond X87-711/721; 115/230V)
- Condensate Pump (Sauermann SI30-115/230; 115/230V)
- Replacement Platinum Deodorizing Filter (MAC-3000FT-E)
- Replacement Anti-allergy Enzyme Filter (MAC-2330FT-E)

#### Controls

- Wireless Controller (MHK1)
- Wired Remote Controller PAR-31MAA (Requires MAC-333IF-E)
- Wireless Interface for kumo cloud™ (PAC-WHS01WF-E)
- Thermostat Interface (PAC-US444CN-1)

# DIMENSIONS: MSZ-FH15NA

## MSZ-FH15NA

Unit: inch

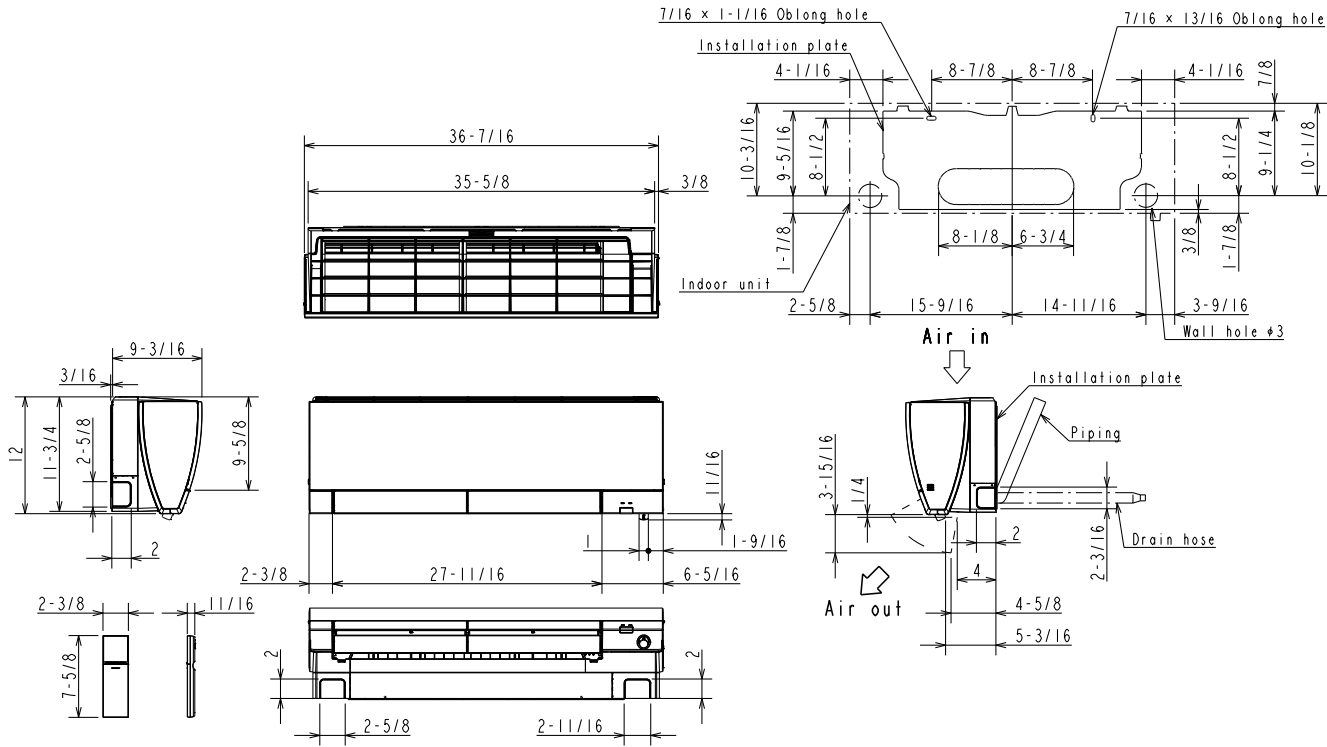

**(MSZ-FH15/18NA/18NA2)**

Piping	Insulation	#1-7/16 O.D
	Liquid line	#1/4 19-11/16 (Flared connection #1/4)
	Gas line	#3/8 16-15/16 (Flared connection #1/2)
Drain hose	Insulation	#1-1/8 Connected part #5/8 O.D



COOLING & HEATING

1340 Satellite Boulevard, Suwanee, GA 30024  
Toll Free: 800-433-4822 www.mehvac.com

