

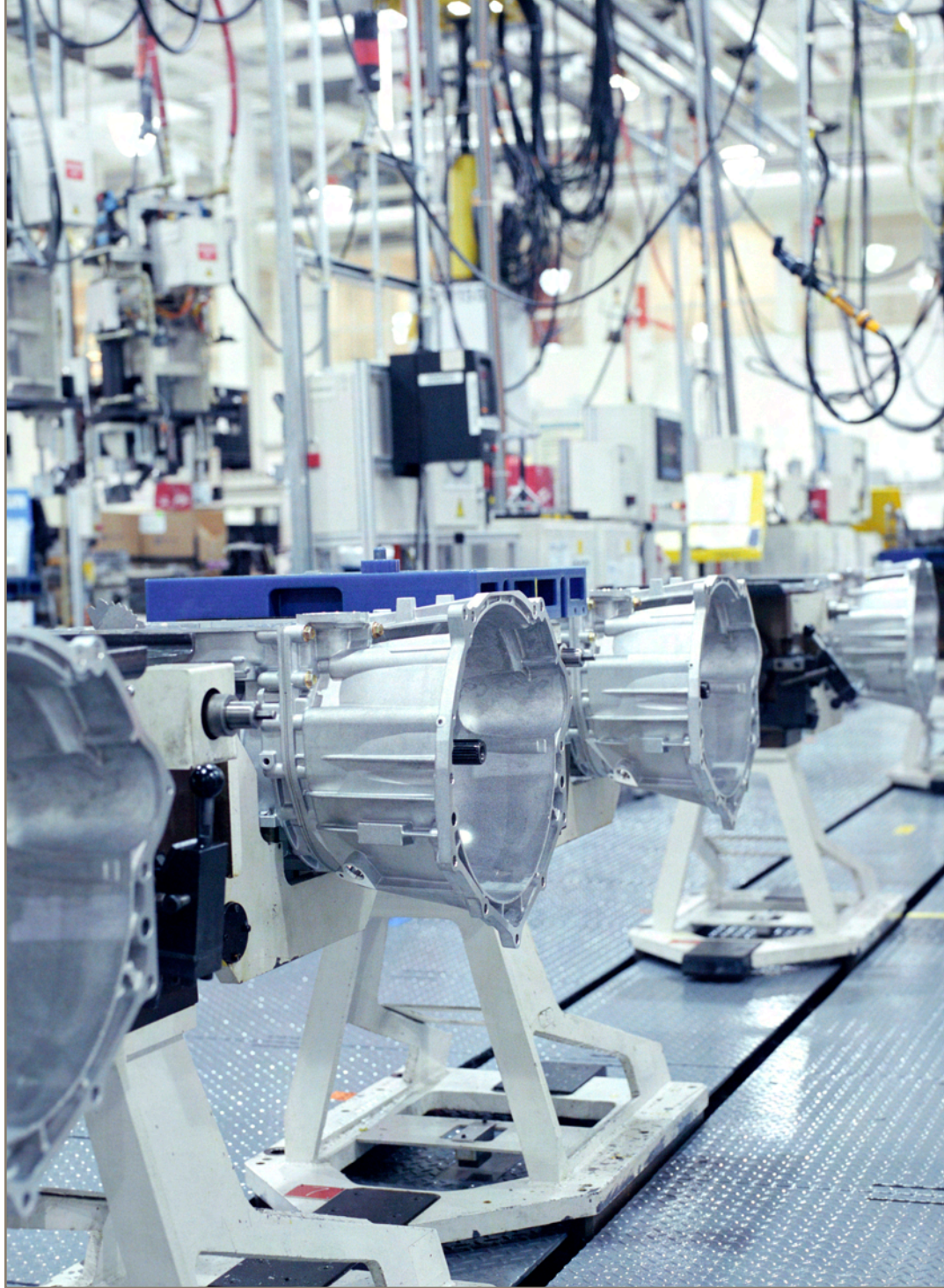

aerospace
climate control
electromechanical
filtration
fluid & gas handling
hydraulics
pneumatics
process control
sealing & shielding



HX Series

High Efficiency Compressed Air Filters



Why Filter Compressed Air?

Product rejects and increased maintenance expenses can occur due to poor air quality

Submicronic contaminants in compressed air systems plug orifices of sensitive pneumatic instrumentation, wear out seals, erode system components, reduce the absorptive capacity of desiccant air/gas dehydrators, foul heat transfer surfaces, reduce air tool efficiency, and damage finished products. The results include

product rejects, lost production time and increased maintenance expense. For example, trace amounts of submicronic oil can cause serious fish eye blemishing in automotive finishing operations. Water left in air lines can freeze during exposure to cold temperatures, blocking flow or rupturing pipes. Compressor lubricant not captured in a

coalescing filter will eventually collect in pneumatic components, causing premature component failure, requiring repair or replacement. Environmental concerns will be raised if oily, compressed air is continually discharge into the atmosphere through a pneumatic muffler.

Finite's HX-Series Offers...

- Coalescing, bulk liquid removal, particulate and adsorption filter elements
- Optional differential pressure gauge, an autodrain, or manual drain
- Temperature to 212°F
- Pressures to 290 PSIG
- Connection sizes from 1/4" to 3" NPT
- Flows from 15 to 1300 SCFM



Why Use Finite Filters?

Numerous Element Types

Our special UNI-CAST formed elements and our deep bed pleated elements provide lower pressure drop and less frequent changeouts, saving you time and money.

HX Meets Your Needs

The HX-Series offers 630 different filter/element variations to meet your application requirement

OEM Capabilities

When you need a special filter for a unique application, Finite filter experts are ready to work with you. We can tailor a configuration to meet your special need from the wide variety of filter media available. In addition, with LEAN manufacturing, we can produce specials in reasonable quantities, in a reasonable amount of time, at a reasonable price. Not only will this enhance the performance of your product, but it will benefit you with aftermarket sales of replacement elements.

HX-Series by the numbers...

- 18 filter housing sizes
- 90 filter element types and sizes
- 10 connection sizes
- 9 filtration media choices: From bulk water separators to 99.995% efficient coalescers
- 2 unique nanofiber coalescing media technologies available, our time-tested UNI-CAST formulation as well as a deep bed pleated nanofiber choice
- 1,000,000's of borosilicate glass nanofibers utilized in each coalescing element made

Clean, energy efficient compressed air is the goal



The key is finding the optimum balance of compressed air quality required, and minimizing the cost and energy needed to achieve that quality.

ISO 8573-1:2010 is now the industry standard for specifying compressed air cleanliness. In this standard, three very common contaminants are focused on, and the various classes describe how clean and dry the compressed air must be in order to achieve that classification. Solid particle content by size range, water content by pressure dewpoint, and oil (including oil vapor) content in mg/m³ is described for each of the classes from Class 0, 1, 2, 3,...,9, and X. Class 0 is described as being as specified by the equipment user and is more stringent than Class 1. Even Class 1, because of its -94 F (-70 C) pressure dewpoint, is rarely required in general industrial settings. Most critical compressed air applications will probably fall into Class 2 described in the table below.

ISO 12500 establishes a uniform test procedure to be used by all filter companies in the compressed air industry. Using this test, air filters can be tested to equate their performance to ISO 8573-1:2010. This procedure specifies exactly how the filters should be tested at either of two inlet challenge levels: 10 mg/m³ or 40 mg/m³. Since high-efficiency filters are often plumbed in series or staged filtration, the prefilters or precoalescers are often rated at the 40 mg/m³ level, and final or polishing coalescing filters are most often rated at the 10 mg/m³ level, since they are typically the beneficiary of prefiltration.

Particulate contamination in a compressed air system can be drawn into the compressor through its intake, or be generated through the compression process or by other system components themselves. Water enters the system through the compressor's intake as humidity in the air. Once compressed the air is saturated meaning that depending on the environment of the system, the water is present either in liquid or vapor state. Oil and hydrocarbon vapors can be drawn into the compressor intake as well, but the largest contributor is carryover of compressor lubricant. See the chart below for typical carryover levels by compressor type.

Using a high performance filter to measure oil aerosol removal, these effects can be observed:

Customary remaining oil content of compressors		
30 ppm	Piston and mobile screw compressors	
12 ppm	Stationary screw compressors	
< 6 ppm	Rotary vane compressors	

Reference conditions 14.5 psi (a) (1 bar (a)), 68°F (20°C), 0 % relative humidity.

ISO Standardization

International Standard ISO8573-1 has become the industry standard method for specifying compressed air cleanliness.

ISO8573-1:2010 CLASS	Solid Particulate			Mass Concentration mg/m ³	Water		Oil	
	Maximum number of particles per m ³				Vapor Pressure Dewpoint	Liquid g/m ³		Total Oil (aerosol liquid and vapor) mg/m ³
	0.1 - 0.5 micron	0.5 - 1 micron	1 - 5 micron					
0	As specified by the equipment user or supplier and more stringent than Class 1							
1	≤ 20,000	≤ 400	≤ 10	-	≤ -94°F (-70°C)	-	0.01	
2	≤ 400,000	≤ 6,000	≤ 100	-	≤ -40°F (-40°C)	-	0.1	
3	-	≤ 90,000	≤ 1,000	-	≤ -4°F (-20°C)	-	1	
4	-	-	≤ 10,000	-	≤ 37.4°F (3°C)	-	5	
5	-	-	≤ 100,000	-	≤ 44.6°F (7°C)	-	-	
6	-	-	-	≤ 5	≤ 50°F (10°C)	-	-	
7	-	-	-	5 - 10	-	≤ 0.5	-	
8	-	-	-	-	-	0.5 - 5	-	
9	-	-	-	-	-	5 - 10	-	
X	-	-	-	> 10	-	> 10	> 5	

New Finite HX-Series Filtration Technology

Our new HX-Series product line possesses many important design and construction features that combine to provide leading compressed air filtration performance. Improved flow characteristics result in lower pressure differential, which is related to the ongoing operating cost of employing high-efficiency nanofiber coalescing filters. They can be used in applications ranging from general shop air all the way up to those which call for extremely critical performance requirements, such as instrument air, breathing air, food and beverage or automotive assembly plant paint systems. The materials used in each filter assembly were chosen not only for compatibility with compressed air system environments, but also to provide a robust and trouble-free system component that can be relied on without worry. Additionally, these filters offer the optional accessory of modular connectors up through the one-inch connection size, enhancing their appeal for OEM usage.

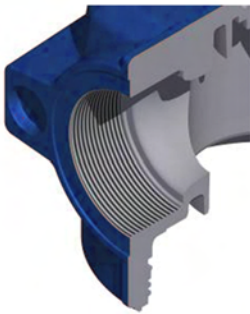

Inlet/Outlet Design

Each HX-Series assembly has an inlet and outlet design which provides a full-flow stream of air into and out of the housing. Connection sizes and flow rates correlate to capacities and connection sizes of various compressor types and sizes, reducing the need for bushings and adaptors.

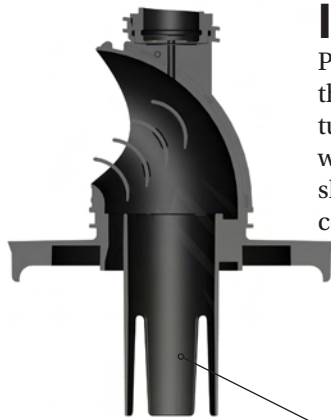

Improved Flow Path

Patented aerospace inspired vanes in the neck of the replaceable filter element ensure unrestricted, turbulent-free laminar flow into the element's core with minimal pressure drop. This design provides no sharp edges or 90 degree elbow turns like traditional coalescing filters.

Flow Distribution

Flow through the core of the element is optimized by use of several features. A patented flow distributor, shown above left ensures that the flow entering the element's core is spread evenly about the inside of the element. At the element's base, a cone-shaped disperser prevents turbulence in the lower region (wet zone) of the element and redirects the air toward the filter media's surface.



Conical Air Disperser

Air flow dispersion at the base of the element helps eliminate turbulence. See photo at left.

Corrosion Protection

All HX-Series filter assemblies are constructed of cast aluminum. Each filter head and bowl is treated with an alocrome process that inhibits corrosion. They are also painted externally with an epoxy based powder paint which provides an extremely durable finish.



Inlet Port Indicators and Differential Sensing Port Plugs

Vertical hash marks are utilized on the top and bottom of the inlet connection port. This feature eliminates any confusion as to which port is the inlet. Although a differential pressure gauge is standard on all larger HX-Series housings, they are also available with threaded and plugged differential sensing ports which can be utilized to connect to remote or standardized monitoring equipment at your facility, or on your mobile equipment.



Patented Locating Tabs and External Flow Stabilizers

Each element possesses two locating tabs of differing size. This allows only one positive fit position into the filter bowl during maintenance, ensuring proper installation and eliminating any chance of mistake. Two external flow stabilizers also located on the element's top end cap are featured to provide an even flow of compressed air exhausting from the element into the housing's exit port.



Surge Shield

A shield is designed into the element on the exterior surface of the element, directly below from the outlet port. This shield is a safety barrier that eliminates any possibility of carryover during system upsets, when slugs of water might otherwise challenge the draining capability of coarser grade filter elements, especially water separators.



Deep Bed Pleated Nanofiber Filter Media

Finite's premium performance 7CP and XF media choices provide excellent filtration efficiency with industry leading low pressure differentials. Lower pressure drop equates to significant energy savings over time and the pleated element's larger surface area (up to 4.5 times) increases element life, providing even greater savings. 7CP (99.5%) is an excellent precoalescer choice while XF provides 99.95% efficiency for final-stage coalescing applications.

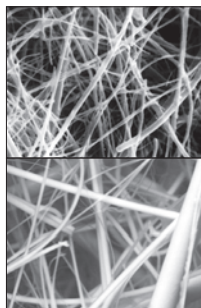

UNI-CAST Nanofiber Filter Media

Finite's unique UNI-CAST manufacturing process continues to provide time-tested and proven performance as only the industry's original cast media manufacturer can do. Seamless cast construction, with 95% void volumes and its graduated pore structure is available in four distinct grades with efficiencies ranging from 95% to 99.995% and micron ratings from 0.01 micron to 1.0 micron. This range enables them to be used in nearly any application as precoalescers as well as final, or polishing coalescers.



Applications

Compressed air, sometimes referred to as industry's fourth utility, has a number of favorable aspects to its use. It is safe, light-weight, dependable, and because it is generated on site, the user has a great deal of control over the compressed air pressure available and its quality. Applications for compressed air are numerous and range from very simple to highly critical. High efficiency compressed air filters like Finite's HX-Series give the user a large array of filtration possibilities so that the user can pick the most effective for their particular applications. The list of applications below is not intended as a comprehensive listing, but gives an overview of the many types of uses there are for the HX-Series product line.

aeration	cooling	nitrogen separation	positioning / locating
air agitators	dairy air	odor removal	pressure testing
air bearings	dental hand pieces	oil vapor adsorption	process air
air dryer pre-filters	dental suction	packaging	robotics
air gauging	desiccant dryer after-filter	parts blow-offs	sandblasting
air hoists	dry bulk solid conveying	PET bottle blowing	snowmaking
air motors	dust collection	plasma welding / cutting	soot blowing
air sparging	fermentation	pneumatic automation	spray painting
atomizing air	filling / capping beverages	pneumatic conveying	sprinkler system charging
bag cleaning	injection molding	pneumatic instruments	tablet coating
bottle filling	instrument air	pneumatic tools	tire filling
breathing air	liquid padding	powder fluidizing	vacuum cups / grasps

The five schematics shown below and on the following page show the major compressed air system components, where filters can be positioned, and the resulting compressed air quality specifications met.

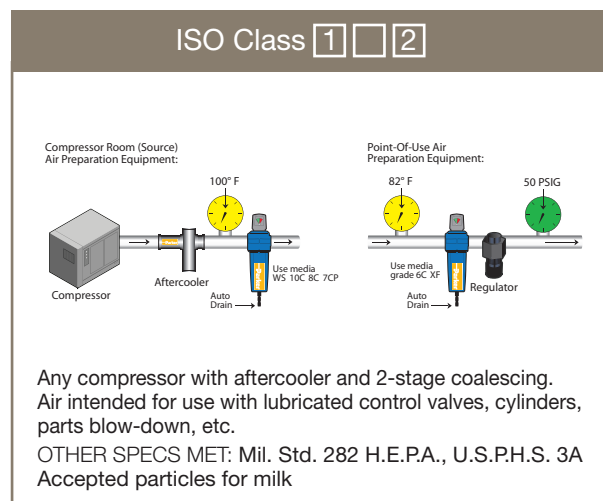
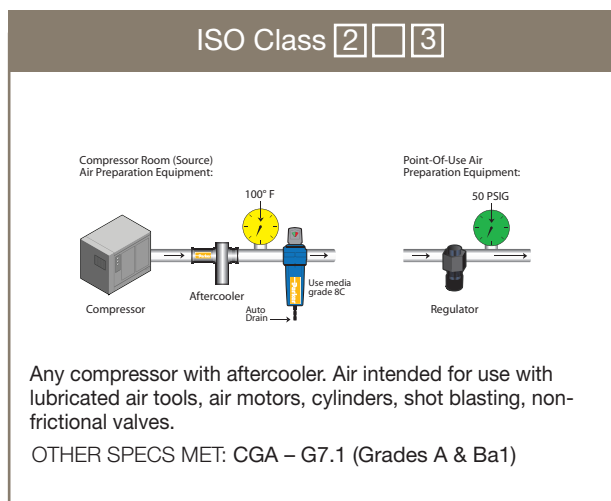

ISO Class 1 4 2

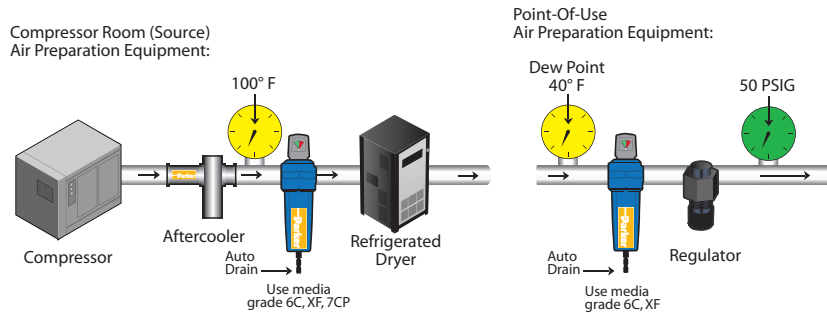

Any compressor with aftercooler, 2-stage coalescing and refrigerated dryer. Air intended for use with air-gauging, air conveyors, spray-painting, food processing, instrumentation, blow molding, cosmetics, film processing, bottling, pharmaceuticals, dairy, breweries, medical, robotics and close tolerance valves.

SPECS MET: CGA – G7.1 (Grades D & E), ISAS7.3 Fed. Std. 209 (Class 100)

ISO Class 1 4 1

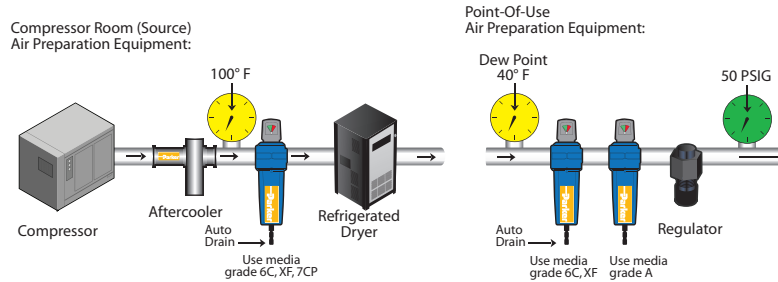

Any compressor with aftercooler, 2-stage coalescing, refrigerated dryer and carbon absorber. Air intended for use as industrial breathing air and decompression chambers. CAUTION: Always use high temperature synthetic lubricants and monitor (alarm for carbon monoxide concentrations). This system will not eliminate toxic gases!

OTHER SPECS MET: O.S.H.A. 29CFR 1910.134

ISO Class 1 2 1

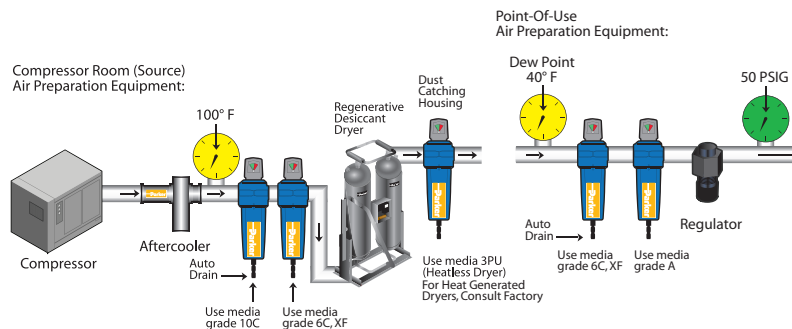

Any compressor with aftercooler, two-stage and double coalescing regenerative-type desiccant dryer and a carbon adsorber. Air intended for use in applications involving rapid expansion of compressed air, critical instrumentation, high purity gases, automotive paint systems, etc. CAUTION: This air is too dry for respiratory use.

Step 1. Determine your application, media grade and media type.

Choose media type from the descriptions below, from the basic application circuits on the previous page, or consult a Finite application engineer. Decide the media grade from the bottom of the following page. If your application requires a coalescing element, use the information listed below. For other media types, please see the following page.

Coalescing Elements (removal of liquids and particulate)

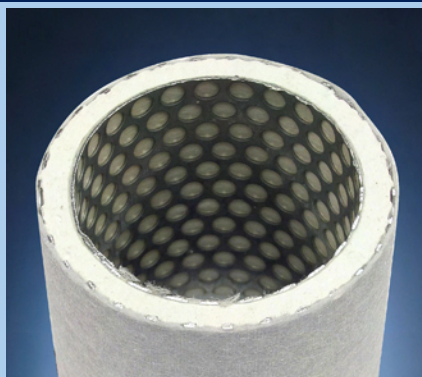

Media type C

Available in grades 4,6,8 or 10

Air Flow: Inside to Outside

This coalescing element is made with our special UNI-CAST construction. Composed of an epoxy saturated, borosilicate glass micro/nano fiber media, this media is used in applications requiring the removal of liquid and particulate contamination. The outer synthetic fabric layer allows swift removal of coalesced liquids.

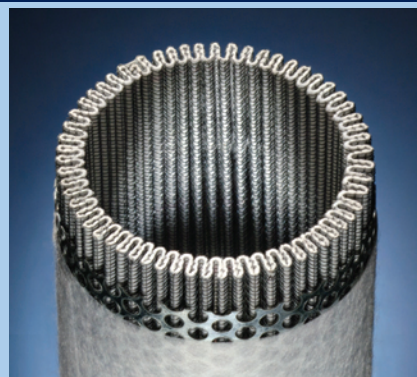

Media type 7CP or XF

Air Flow: Inside to Outside

Finite's 7CP media type consists of two filter layers between metal retainers. The outer layer removes aerosols while the inner layer traps solid particles, protecting and extending the life of the outer layer. 7CP elements are used in bulk liquid coalescing applications or when relatively high efficiency and low pressure drop are required.

Finite's XF media type are constructed similarly to the 7CP, but offer even higher filtration efficiency for more critical compressed air quality demands.

Media type C... Choose your grade...

Grade 4

Finite's media grade 4 is typically chosen when an extremely high coalescing efficiency is required. Its 99.995% rating is the best available and is ideal for use as a final filter in applications with elevated operating pressures up to 290 PSIG. Grade 4's higher operating pressure drop can be reduced by oversizing. Consult factory.

Grade 6 (Standard)

Grade 6 filters are used when "total removal of liquid aerosols and suspended fines" is required. Because of its overall performance characteristics, this grade is most often recommended in a variety of industrial applications. Grade 6 is an excellent choice as a prefilter for regenerative desiccant air dryers, as it prevents oil or varnish from coating the desiccant.

Grade 8

Grade 8 filters combine high efficiency (98.5%) with high flow rate and long element life. A separate prefilter is not required for "normal to light" particulate loading. A grade 8 element is often chosen as protection for refrigerated air dryers. This element allows the dryer to maintain efficiency by preventing the coating of copper coils with the build-up of oil or varnish.

Grade 10

Grade 10 filters are used as pre-filters for grades 6 or 8 to remove gross amounts of liquid aerosols or tenacious aerosols. Grade 10 is often referred to as a coarse coalescer, or pre-coalescer. It is typically followed by a grade 6C final filter.

Water Separator Element (removal of bulk liquids)

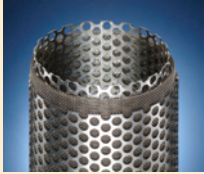

Media type WS

Air Flow: Inside to Outside

This rolled stainless steel mesh element has ID and OD metal retainers with rolled stainless steel mesh in between. It is an extremely robust design. With a nominal rating of 100 micron, this media is used for the reduction and elimination of excess liquids in gas streams. It also would be a good choice as a prefilter for coalescing grades 6 and 10 when extreme volumes of liquid contaminants are present.

Interceptor Element (removal of solids)

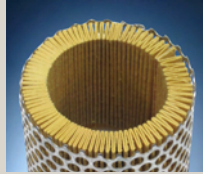

Media type 3P

Air Flow: Inside to Outside

Finite's 3P pleated cellulose element removes solid contaminants, with a 3 micron absolute rating. Because this element is designed to flow from its inside to the outside, it has a strong outer retainer that gives this element added strength. 3P particulate "Interceptor" elements are used where very high dirt loading is expected but a relatively fine pore structure is required. It is also used as a prefilter to a coalescing filter in systems where a lot of solid contamination exists.

Adsorption Element (removal of odor)

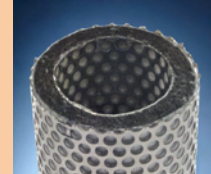

Media type A

Air Flow: Inside to Outside

This hydrocarbon vapor removal element consists of an ultra-fine grained, highly concentrated, activated carbon sheet media. Because these elements are designed to flow from the inside to their outside, they have a strong outer retainer giving this element added strength. This media type is used to remove hydrocarbon vapor and is often used to remove the smell or taste of compressor lube oil from breathing air.

Finite Media Specifications

Media Grade	Coalescing Efficiency 0.3 to 0.6 Micron Particles	Micron Rating	Aerosol Content per ISO 12500-1	Maximum Oil Carryover (mg/m ³)	ISO Class*	Operating ΔP	Recommended Prefilter
4C	99.995%	0.01	10	0.0005	1,_,2	5.4 - 6.7	10C or 7CP
6C	99.97%	0.01	10	0.003	1,_,2	3.0 - 4.0	10C or 7CP
XF	99.95%	0.3	10	0.05	1,_,2	1.5 - 2.0	7CP
7CP	99.5%	0.5	40	0.2	2,_,3	0.7 - 1.2	WS or 3P
8C	98.5%	0.5	40	0.6	2,_,3	1.0 - 1.4	WS or 3P
10C	95%	1.0	40	2	2,_,4	0.7 - 1.0	WS or 3P
WS	99+%	100	NA	NA	NA	0.7 - 1.2	NA
3P	N/A	3.0	NA	NA	3,_,_	0.7 - 1.2	NA
A	99+%	3.0	NA	NA	2,_,3	3.0 - 4.0	6C or XF

Note 1: Tested per ISO 12500-1 at specified inlet content.

Note 2: "*" Indicates suitability in accordance with ISO 8573-1:2010

Note 3: Grades 4C, 6C and XF could be used to achieve Class 1,_,1 if followed by a Grade A oil vapor adsorber.

Note 4: Bulk liquid removal efficiency is given for WS media.

Note 5: Oil vapor removal efficiency is given for A media.

Step 2. Determine your housing

Find your desired flow rate under the appropriate media grade column. For pressures other than 100 PSIG or temperatures other than 70°F, please see Alternate Housing Selection Chart, Step 2a, below.

Housing Selection Chart

Rated Flows: SCFM @ 100 PSIG; These flowrates can be exceeded by 10% and will still meet filtration efficiencies. For other pressures, please see Step 2a below.

				Rated Flows (SCFM) at 100 PSIG Operating Pressure, 70°F Operating Temperature								
Housing Assembly	Media Grade	Accessory (see step 3)	Conn (NPT)	Final Stage Coalescers			Pre-Coalescers			Water Sep.	Particulate	Vapors
				4C	6C	XF	7CP	8C	10C	WS	3P	A
HXN1A-	---	<input type="checkbox"/>	1/4"	15	15	20	20	15	15	15	15	15
HXN15B-	---	<input type="checkbox"/>	3/8"	35	35	40	40	35	35	35	35	35
HXN2B-	---	<input type="checkbox"/>	1/2"	35	35	40	40	35	35	35	35	35
HXN2BH-	---	<input type="checkbox"/>	1/2"	50	50	65	65	50	50	50	50	50
HXN3BH-	---	<input type="checkbox"/>	3/4"	50	50	65	65	50	50	50	50	50
HXN3C-	---	<input type="checkbox"/>	3/4"	100	100	125	125	100	100	100	100	100
HXN4C-	---	<input type="checkbox"/>	1"	100	100	125	125	100	100	100	100	100
HXN4D-	---	<input type="checkbox"/>	1"	180	180	230	230	180	180	180	180	180
HXN5D-	---	<input type="checkbox"/>	1-1/4"	180	180	230	230	180	180	180	180	180
HXN6D-	---	<input type="checkbox"/>	1-1/2"	180	180	230	230	180	180	180	180	180
HXN5E-	---	<input type="checkbox"/>	1-1/4"	320	320	340	340	320	320	320	320	320
HXN6E-	---	<input type="checkbox"/>	1-1/2"	320	320	340	340	320	320	320	320	320
HXN8E-	---	<input type="checkbox"/>	2"	320	320	340	340	320	320	320	320	320
HXN8F-	---	<input type="checkbox"/>	2"	430	430	465	465	430	430	430	430	430
HXN8G-	---	<input type="checkbox"/>	2"	540	540	700	700	540	540	540	540	540
HXN10H-	---	<input type="checkbox"/>	2-1/2"	650	650	900	900	650	650	650	650	650
HXN12H-	---	<input type="checkbox"/>	3"	650	650	900	900	650	650	650	650	650
HXN12J-	---	<input type="checkbox"/>	3"	900	900	1300	1300	900	900	900	900	900

Step 2a. Alternate Housing Selection Chart

Use this step for applications that do not have standard conditions (100 PSIG and 70°F).

Because the required size of a filter is affected not only by flow, but also by operating pressure and operating temperature, it is necessary to convert those actual conditions to standardized conditions (100 PSIG and 70°F).

The calculated adjusted flow rate can then be used to choose the appropriate filter in the chart on the previous page. When using the chart, choose the closest flow rate from the appropriate media grade column.

ATTENTION  **NOTE: HX-Series is designed for use with compressed air and inert gases such as nitrogen. It can not be used with flammable or poisonous gases.**

Sizing Equation						
Flow Rate		Pressure:		Temperature:		Adjusted Flow Rate
Actual System Flow Rate (SCFM)	X	$\frac{(100 \text{ PSIG} + 14.7 \text{ PSIG})}{(\text{System Pressure (PSIG)} + 14.7 \text{ PSIG})}$	X	$\frac{(\text{System Temp. } ^\circ\text{F} + 460^\circ\text{F})}{70^\circ\text{F} + 460^\circ\text{F}}$	X	$\sqrt{\frac{1.0 \text{ (specific gravity of gas)}}{\text{Specific Gravity (Air = 1.0)}}}$ = _____ SCFM @ 100 PSIG, 70°F

Example:

$$136 \text{ SCFM} \frac{(100 \text{ PSIG} + 14.7 \text{ PSIG})}{(150 \text{ PSIG} + 14.7 \text{ PSIG})} \times \frac{(100^\circ\text{F} + 460^\circ\text{F})}{70^\circ\text{F} + 460^\circ\text{F}} \times \sqrt{1} = 100 \text{ SCFM}$$

Information Given:
 Flow Rate = 136 SCFM
 Pressure = 150 PSIG
 Actual Temperature = 100°F
 Gas = Air

Step 3. Accessories

Consult Finite when choosing pre-installed accessories for gases other than air.



Pre-installed Accessories

*Note: Auto drains require a minimum operating pressure of 10 PSIG to seal.

Accessory Designator	Installed Accessory	Maximum Pressure	Maximum Temperature	Standard / Optional
N	Manual Drain	290 psi g	212°F	Optional on all model sizes
A	Auto Drain	250 psi g	175°F	Standard on all model sizes
G	DP Gauge + Manual Drain	230 psi g	175°F	Optional on models HXN15B - HXN4C
Y	Auto Drain and DP Gauge	230 psi g	175°F	Standard on models HXN4D - HXN12J

Other Compatible Drain Accessories

TV-50 Timed Drain Valve	ZLD-013 Zero Loss Drain	VS-50 Visual Sump Drain (not shown: standard bowl guard)	MS-50 Metal Sump Drain (External)
210° F (99° C)	140° F (60° C)	125° F (52° C)	175° F (79° C)
300 PSIG (20 Bar)	232 PSIG (16 Bar)	150 PSIG (10 Bar)	250 PSIG (17 Bar)
1/2" NPT	1/2" NPT	1/2" NPT	1/2" NPT

Replacement Accessories

P/N	Type	Fits Filter Size:	Description
2205HX	Manual Drain	HXN1A - HXN12J	1/2" NPT
2206HX	Auto Drain	HXN1A - HXN12J	Includes 5/16" tube union
2198HX	DP Gauge	HXN15B - HXN12J	Mounts on ports on head; bilateral display

Note: The accessories above are compatible with this product line. Consult factory for other accessory options and availability.

Step 4. How to Order

HX Series Filter Assemblies

Series	Thread	Conn.	Bowl Size
HX	N	3	C
HX	N-NPT	1 = 1/4"	A
		15 = 3/8"	B
		2 = 1/2"	B, BH
		3 = 3/4"	BH, C
		4 = 1"	C, D
		5 = 1-1/4"	D, E
		6 = 1-1/2"	D, E
		8 = 2"	E, F, G
		10 = 2-1/2"	H
12 = 3"	H, J		

Element Type	Accessories
6C	Y
4C	N = No Accessories, Manual Drain (optional on all model sizes) A = Auto Drain (standard on all model sizes) G = Diff. Pressure Gauge (gauge not available on model HXN1A) and manual drain Y = Auto Drain and Diff. Pressure Gauge (standard on models HXN4D - HXN12J) Note: G and Y options not available on HXN1A versions
6C	
8C	
10C	
7CP	
XF	
WS	
3P	
A	

Examples: HXN1A-6CN, HXN2BH-WSA, HXN12J-XFY, HXN8G-6CG

HX Series Replacement Elements

The kit includes the replacement element with o-rings, the head-to-bowl o-ring, and lube.

Element Type	Series	Bowl Size	Kit
6C	HX	C	K
4C	HX	A	K = Kit
6C		B	
8C		BH	
10C		C	
7CP		D	
XF		E	
WS		F	
3P		G	
A		H	
		J	



Examples: 6CHXAK, WSHXBHK, XFHXJK, 6CHXGK

Replacement Element Part Numbers

Housing Assembly	Conn (NPT)	4C	6C	XF	7CP	8C	10C	WS	3P	A
HXN1A-	1/4"	4CHXAK	6CHXAK	XFHXAK	7CPHXAK	8CHXAK	10CHXAK	WSHXAK	3PHXAK	AHXAK
HXN15B-	3/8"	4CHXBK	6CHXBK	XFHXBK	7CPHXBK	8CHXBK	10CHXBK	WSHXBK	3PHXBK	AHXBK
HXN2B-	1/2"									
HXN2BH-	1/2"	4CHXBHK	6CHXBHK	XFHXBHK	7CPHXBHK	8CHXBHK	10CHXBHK	WSHXBHK	3PHXBHK	AHXBHK
HXN3BH-	3/4"									
HXN3C-	3/4"	4CHXCK	6CHXCK	XFHXCK	7CPHXCK	8CHXCK	10CHXCK	WSHXCK	3PHXCK	AHXCK
HXN4C-	1"									
HXN4D-	1"	4CHXDK	6CHXDK	XFHXDK	7CPHXDK	8CHXDK	10CHXDK	WSHXDK	3PHXDK	AHXDK
HXN5D-	1-1/4"									
HXN6D-	1-1/2"									
HXN5E-	1-1/4"	4CHXEK	6CHXEK	XFHXEK	7CPHXEK	8CHXEK	10CHXEK	WSHXEK	3PHXEK	AHXEK
HXN6E-	1-1/2"									
HXN8E-	2"									
HXN8F-	2"	4CHXFK	6CHXFK	XFHXFK	7CPHXFK	8CHXFK	10CHXFK	WSHXFK	3PHXFK	AHXFK
HXN8G-	2"	4CHXGK	6CHXGK	XFHXGK	7CPHXGK	8CHXGK	10CHXGK	WSHXGK	3PHXGK	AHXGK
HXN10H-	2-1/2"	4CHXHK	6CHXHK	XFHXHK	7CPHXHK	8CHXHK	10CHXHK	WSHXHK	3PHXHK	AHXHK
HXN12H-	3"									
HXN12J-	3"	4CHXJK	6CHXJK	XFHXJK	7CPHXJK	8CHXJK	10CHXJK	WSHXJK	3PHXJK	AHXJK

Examples on How to Order:

Example 1:

HXN1A-6CN

What am I ordering?

An HX-Series with a 1/4" NPT connection, A-size bowl, a standard grade 6 coalescing element with no accessories, manual drain only.

Example 2:

6CHXAK

What am I ordering?

An HX-Series replacement element kit, a grade 6 coalescing element, for an A-size bowl. This kit includes the replacement element with o-ring, head-to-bowl o-ring and lube.

Example 3:

HXN12J-XFY

What am I ordering?

An HX-Series with a 3" NPT connection with a J-size bowl, an XF coalescing element with a Y accessory option which includes an auto drain and differential pressure gauge.

Example 4:

XFHXJK

What am I ordering?

An HX-Series replacement element kit, with an XF coalescing element for a J-size bowl. The kit includes the replacement element with o-rings, the head-to-bowl o-ring and lube.

Drawings, Dimensions, and Specifications

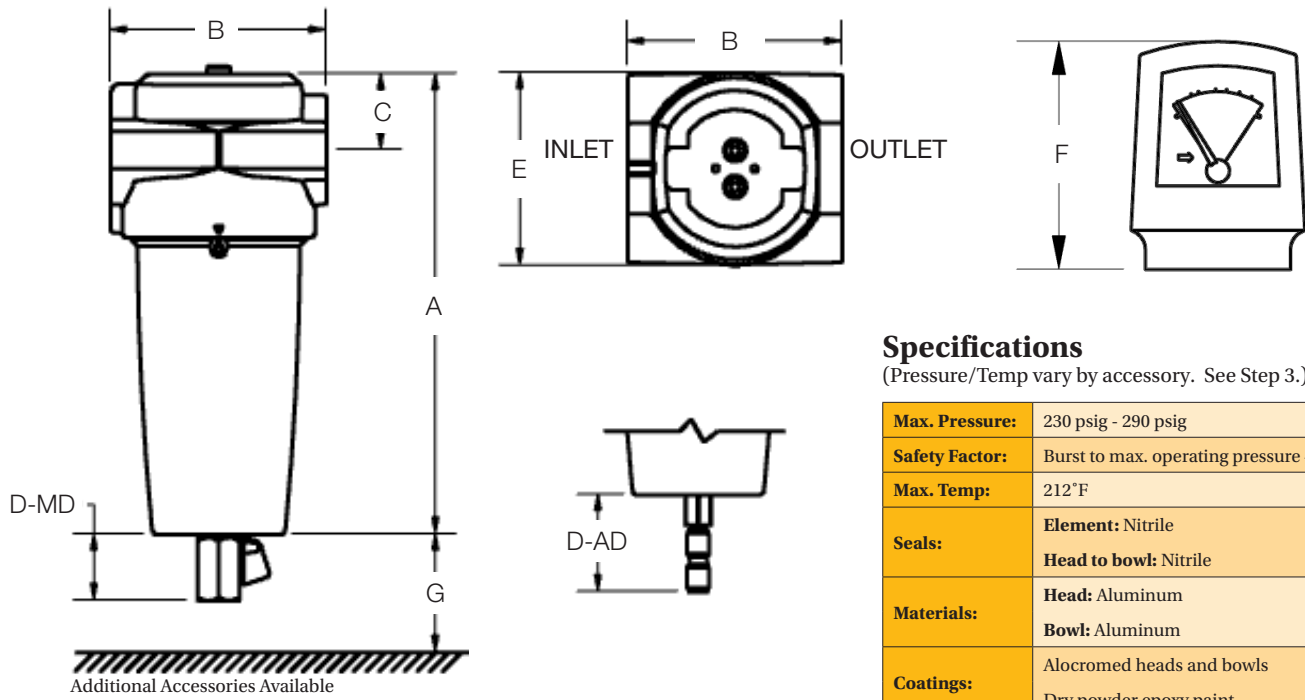

Specifications

(Pressure/Temp vary by accessory. See Step 3.)

Max. Pressure:	230 psig - 290 psig
Safety Factor:	Burst to max. operating pressure 4:1
Max. Temp:	212°F
Seals:	Element: Nitrile Head to bowl: Nitrile
Materials:	Head: Aluminum Bowl: Aluminum
Coatings:	Alocromed heads and bowls Dry powder epoxy paint

Weights and Dimensions

Model No.	Conn. (NPT)	A (in.)	B (in.)	C (in.)	D-MD (in.)	D-AD (in.)	E (in.)	F (in.)	G (in.)	Sump (oz.)	Wt. (lbs.)
HXN1A-	1/4"	7.0	2.6	0.9	1.6	2.4	2.6	N/A	1.2	2.7	1.4
HXN15B-	3/8"	9.4	3.5	1.5	1.6	2.4	3.4	2.7	1.9	7.4	3.1
HXN2B-	1/2"	9.4	3.5	1.5	1.6	2.4	3.4	2.7	1.9	7.4	3.1
HXN2BH-	1/2"	9.4	3.5	1.5	1.6	2.4	3.4	2.7	1.9	4.4	3.1
HXN3BH-	3/4"	9.4	3.5	1.5	1.6	2.4	3.4	2.7	1.9	4.4	3.1
HXN3C-	3/4"	10.9	5.1	1.8	1.6	2.3	4.6	2.7	2.6	8.6	6.3
HXN4C-	1"	10.9	5.1	1.8	1.6	2.3	4.6	2.7	2.6	8.6	6.3
HXN4D-	1"	14.5	5.1	1.8	1.6	2.3	4.6	2.7	2.6	7.4	7.2
HXN5D-	1-1/4"	14.5	5.1	1.8	1.6	2.3	4.6	2.7	2.6	7.4	7.2
HXN6D-	1-1/2"	14.5	5.1	1.8	1.6	2.3	4.6	2.7	2.6	7.4	7.2
HXN5E-	1-1/4"	17.3	6.5	2.2	1.6	2.4	6.2	2.7	3.9	12.8	9.5
HXN6E-	1-1/2"	17.3	6.5	2.2	1.6	2.4	6.2	2.7	3.9	12.8	9.5
HXN8E-	2"	17.3	6.5	2.2	1.6	2.4	6.2	2.7	3.9	12.8	9.5
HXN8F-	2"	20.9	6.5	2.2	1.6	2.4	6.2	2.7	3.9	12.3	15.9
HXN8G-	2"	27.7	6.5	2.2	1.6	2.4	6.2	2.7	3.9	11.1	19.9
HXN10H-	2-1/2"	25.7	7.6	2.8	1.7	2.4	7.2	2.7	4.7	22.0	26.9
HXN12H-	3"	25.7	7.6	2.8	1.7	2.4	7.2	2.7	4.7	22.0	26.9
HXN12J-	3"	33.2	7.6	2.8	1.7	2.4	7.2	2.7	4.7	22.0	31.0

Aftermarket Accessories and Spare Parts

Modular Connectors and Mounting Bracket Kits

(includes mounting brackets, threaded rods, hex flange locknuts, and gaskets if necessary)

P/N	Filter Size	Includes
2207HX	HXN1A - 1 Housing	2 brackets, 2 threaded rods, 4 flanged lock nuts
2208HX	HXN1A - 2 Housings	2 brackets, 2 threaded rods, 4 flanged lock nuts, 1 gasket
2209HX	HXN1A - 3 Housings	2 brackets, 2 threaded rods, 4 flanged lock nuts, 2 gaskets
2210HX	HXN15B - HXN3BH - 1 Housing	2 brackets, 2 threaded rods, 4 flanged lock nuts
2211HX	HXN15B - HXN3BH - 2 Housings	2 brackets, 2 threaded rods, 4 flanged lock nuts, 1 gasket
2212HX	HXN15B - HXN3BH - 3 Housings	2 brackets, 2 threaded rods, 4 flanged lock nuts, 2 gaskets
2213HX	HXN3C - HXN6D - 1 Housing	2 brackets, 2 threaded rods, 4 flanged lock nuts
2214HX	HXN3C - HXN6D - 2 Housings	2 brackets, 2 threaded rods, 4 flanged lock nuts, 1 gasket
2215HX	HXN3C - HXN6D - 3 Housings	2 brackets, 2 threaded rods, 4 flanged lock nuts, 2 gaskets

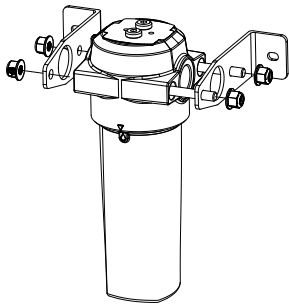

Example shown: 2210HX,
1 housing with mounting brackets

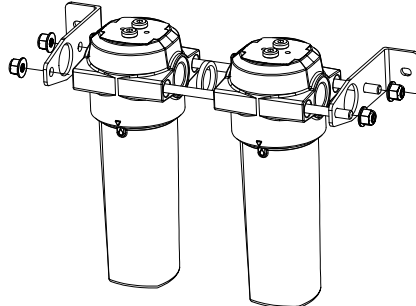

Example shown: 2211HX,
2 housings with modular connector
and mounting brackets

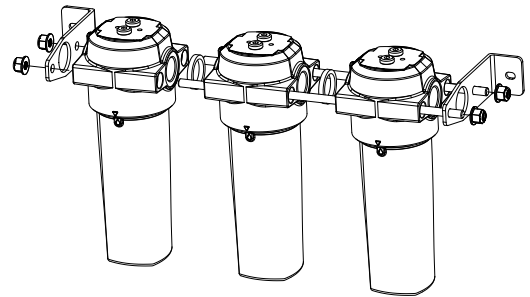

Example shown: 2212HX,
3 housings with modular connector
and mounting brackets

Seal Kits

(includes o-ring and lube)

P/N	Includes
2200HX	Head-to-bowl o-ring kit for model HXN1A
2201HX	Head-to-bowl o-ring kit for models HXN15B - HXN3BH
2202HX	Head-to-bowl o-ring kit for models HXN3C - HXN6D
2203HX	Head-to-bowl o-ring kit for models HXN5E - HXN8G
2204HX	Head-to-bowl o-ring kit for models HXN10H - HXN12J

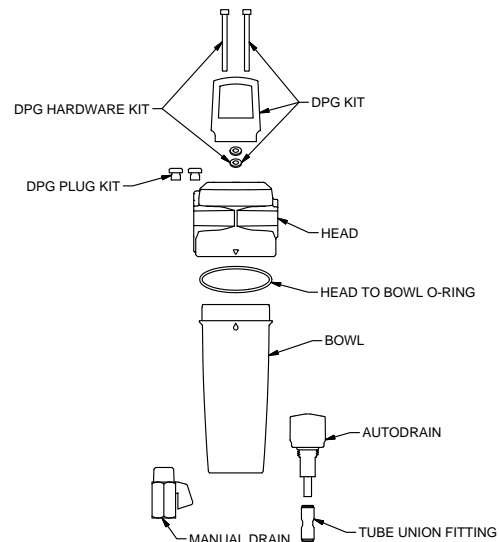

Other Spare Parts

P/N	Includes
2199HX	DP Hardware Kit (includes 2 gaskets and 2 screws only)
2220HX	DP Plug Kit (includes 2 DP plugs, 2 gaskets)



More than 75% of our standard items are made to order and ready for shipment within three days of order confirmation.

Superior Design and Construction

Our UNI-CAST nanofiber filters, formed with a unique vacuum process, combine surface (edge) filtration with enhanced depth filtration. UNI-CAST pore construction traps larger poreclogging particles on the surface while allowing access to the element's internal fiber matrix for coalescing and submicronic particulate removal. The result is lower pressure drop and less frequent change-outs saving you time and money. Our deep bed pleated nanofiber filters offer even lower pressure drop performance coupled with excellent capture efficiencies.

Exceptional Lead Times

Our LEAN manufacturing capability assures that you will have the right filtration product at the right time. More than 75% of our standard items are made to order and ready for shipment within three days of order confirmation. This enables us to meet 98% of customers' request dates.

Outstanding Technical Assistance

We are committed to providing unmatched technical support to all our customers. Our degreed application engineers provide immediate response to technical questions and requests for specifications and quotes whenever possible. If they are busy serving other customers when you call, they make every effort to return your call within the hour.

www.parker.com/finitefilter

Superior, Consistent Performance

Superior, consistent performance is as vital to your operation as it is to ours. Certified to ISO 9001:2008 and ISO 14001:2004 Environmental Management Standard, our quality management systems provide products that meet your filtration requirements and exceed your performance expectations. Combined with our superior filter design, Finite filters produce lower differential pressures and higher dirt-holding capacity. Offered in a variety of efficiencies, the media you select will fit your filtration needs.



Worldwide Filtration Manufacturing Locations

North America

**Compressed Air Treatment
Filtration & Separation/Balston**
Haverhill, MA
978 858 0505
www.parker.com/balston

**Finite Airtek Filtration
Airtek/domnick hunter/Zander**
Lancaster, NY
716 686 6400
www.parker.com/faf

Finite Airtek Filtration/Finite
Oxford, MI
248 628 6400
www.parker.com/finitefilter

**Engine Filtration &
Water Purification
Racor**
Modesto, CA
209 521 7860
www.parker.com/racor

Holly Springs, MS
662 252 2656
www.parker.com/racor

Beaufort, SC
843 846 3200
www.parker.com/racor

Racor – Village Marine Tec.
Gardena, CA
310 516 9911
desalination.parker.com

Parker Sea Recovery
Carson, CA
310 637 3400
www.searecovery.com

**Hydraulic Filtration
Hydraulic Filter**
Metamora, OH
419 644 4311
www.parker.com/hydraulicfilter

Laval, QC Canada
450 629 9594
www.parkerfarr.com

**Process Filtration
domnick hunter Process Filtration**
Oxnard, CA
805 604 3400
www.parker.com/processfiltration

Madison, WI
608 824 0500
www.scilog.com

Phoenixville, PA
610 933 1600
www.parker.com/processfiltration

**Aerospace Filtration
Velcon Filtration**
Colorado Springs, CO
719 531 5855
www.velcon.com

Europe

**Compressed Air Treatment
domnick hunter Filtration & Separation**
Gateshead, England
+44 (0) 191 402 9000
www.parker.com/dhfn

Parker Gas Separations
Etten-Leur, Netherlands
+31 76 508 5300
www.parker.com/dhfn

Hiross Zander
Padova Business Unit
Padova, Italy
+39 049 9712 111
www.parker.com/hz

Hiross Zander
Essen Business Unit
Essen, Germany
+49 2054 9340
www.parker.com/hz

**Engine Filtration &
Water Purification
Racor**
Dewsbury, England
+44 (0) 1924 487 000
www.parker.com/rfde

Racor Research & Development
Stuttgart, Germany
+49 (0)711 7071 290-10
www.parker.com/rfde

**Hydraulic Filtration
Hydraulic Filter**
Arnhem, Holland
+31 26 3760376
www.parker.com/hfde

Ujala Operation
Ujala, Finland
+358 20 753 2500
www.parker.com/hfde

Condition Monitoring Centre
Norfolk, England
+44 (0) 1842 763 299
www.parker.com/hfde

Parker Kittiwake
West Sussex, England
+44 (0) 1903 731 470
www.kittiwake.com

Parker Procal
Peterborough, England
+44 (0) 1733 232 495
www.kittiwake.com

**Process Filtration
domnick hunter Process Filtration**
Birtley, England
+44 (0) 191 410 5121
www.parker.com/processfiltration

Parker Twin Filter BV
Zaandam, Netherlands
+31(0)75 655 50 00
www.twinfilter.com

Asia Pacific

Australia
Castle Hill, Australia
+61 2 9634 7777
www.parker.com/australia

China
Shanghai, China
+86 21 5031 2525
www.parker.com/china

India
Navi Mumbai, India
+91 22 651 370 8185
www.parker.com/india

Parker Fowler
Bangalore, India
+91 80 2783 6794
www.johnfowlerindia.com

Japan
Tokyo, Japan
+81 45 870 1522
www.parker.com/japan

Parker Techno
Osaka, Japan
+81 66 340 1600
www.techno.taiyo-ltd.co.jp

Korea
Hwaseon-City
+82 31 359 0852
www.parker.com/korea

Singapore
Jurong Town, Singapore
+65 6887 6300
www.parker.com/singapore

Thailand
Bangkok, Thailand
+66 2186 7000
www.parker.com/thailand

**Latin America
Parker Comercio Ltda.
Filtration Division**
Sao Paulo, Brazil
+55 12 4009 3500
www.parker.com/br

Pan American Division
Miami, FL
305 470 8800
www.parker.com/panam

Africa

Aeroporto Kempton Park, South Africa
+27 11 9610700
www.parker.com/africa



Parker Hannifin Corporation
Finite Airtek Filtration Division
500 S. Glaspie Street
Oxford, MI 48371
phone 248 628 6400
fax 248 628 1850
www.parker.com/finitefilter

