

# Cart Body Assembly Parts

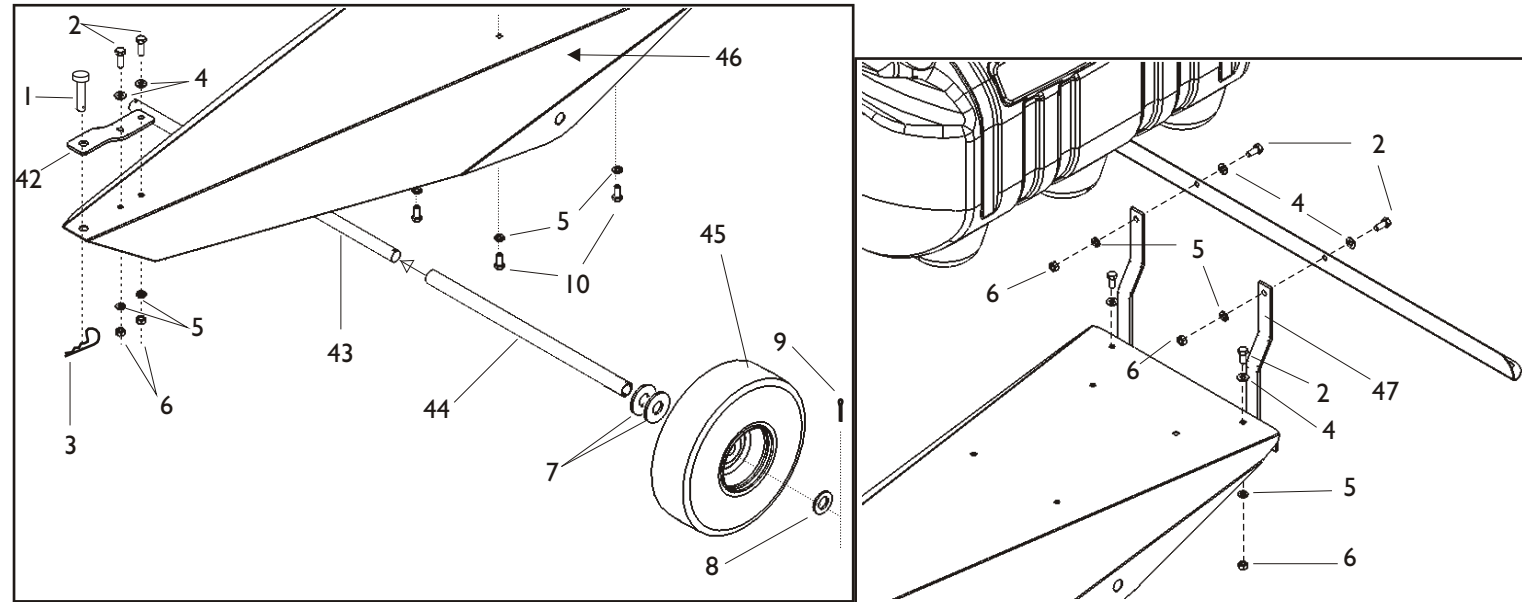

Ref.	Part Description	Part Number	Qty.	Ref.	Part Description	Part Number	Qty.
1	1/2" x 1-3/4" Clevis Pin	1840	1	42	Clevis	1243P	1
2	5/16" x 3/4" Hex Head Bolt	1248	6	43	Axle	3793	1
3	#14 Hitch Pin Clip	1042	1	44	Axle Tube Spacer	3767	1
4	5/16" Flat Washer	1044	6	45	10" Pneumatic Wheel for TCT	3339	2
5	5/16" Lock Washer	1276	10	46	TCT Cart Body	3794R	1
6	5/16" Hex Head Nut	1275	6	47	Boom Mount	3766R	1
7	5/8" x 1 3/4" Flat Washer	3664	4				
8	5/8" Flat Washer	1646	2				
9	1/8" x 1-1/4" Cotter Pin	1262	2				
10	5/16" x 1/2" Hex Head Bolt	1762	4				

**\*\*Part quantities includes pieces assembled at factory and those in hardware sack.**

## CUSTOMER SUPPORT

At Precision Products, Inc. delivering quality, value and outstanding service is our goal. However, sometimes parts do become damaged or lost during transport from our facilities to the store. **If you have any problems, please do not return this merchandise to the store. Call us and we will take care of any problem you may have with this unit.**

*The electric pump on this model has its own warranty. Precision Products, Inc. does not carry a warranty on the pump. Please refer to the parts list and operation manual for the pump included with this model.*

## Customer Service

When ordering parts, always give model number, part description, & part number.

**Send To:** Precision Products, Inc.  
 Parts Division  
 316 Limit Street  
 Lincoln, IL 62656

**Phone** (217)735-1590  
**Fax** (217)735-2435

or visit us on the world wide web :[www.precisionprodinc.com](http://www.precisionprodinc.com)

**PRECISION PRODUCTS, INC.**

## LIMITED WARRANTY

This unit is warranted against defects in materials and workmanship to the original purchaser, under normal use and service, for a period of ninety (90) days from date of sale. During the Warranty Period, we will repair or replace at our option free of charge to the original purchaser, any part of the Unit that our examination shows to be defective in workmanship or materials. This Warranty **Does Not** apply to damage caused by misuse, abuse, neglect, accident, normal wear, or alterations by unauthorized persons.

# TCT15 Trailer Sprayer

## TCT15RT ASSEMBLY INSTRUCTIONS & PARTS LIST

3736-9

09/06

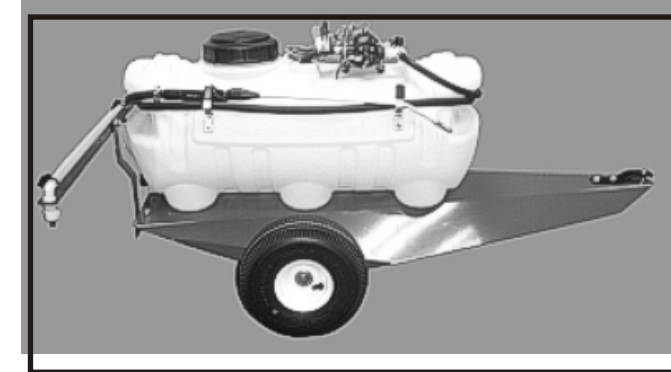

**PRECISION PRODUCTS, INC.**

## Assembly Instructions

### Tools needed for assembly:

- Two 1/2" Wrenches
- 1 Pair Needle Nose Pliers

### Assembly Hardware

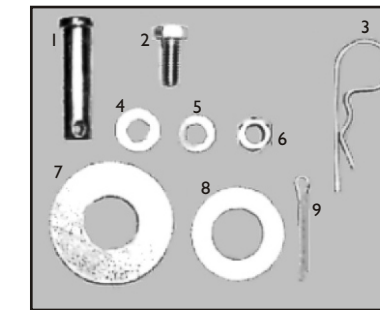

Ref. No.	Part No.	Part Description	Hardware Sack Qty.
1	1840	1/2" x 1-3/4" Clevis Pin	1
2	1248	5/16" x 3/4" Hex Head Bolt	6
3	1042	#14 Hitch Pin Clip	1
4	1044	5/16" Flat Washer	6
5	1276	5/16" Lock Washer	6
6	1275	5/16" Hex Head Nut	6
7	3664	5/8" x 1 3/4" Flat Washer	4
8	1646	5/8" Flat Washer	2
9	1262	1/8" x 1-1/4" Cotter Pin	2

**STEP 1** Insert Axle through Axle Slot on Cart Body. Once the Axle is through the hole, slide on one 3/4" x 2" Flat Washer(7) then the Axle Tube Spacer(44), then slide the Axle through to the end of the Axle Tube Spacer. Add another 3/4" x 2" Flat Washer (inside of the Sprayer Cart body) and push the Axle through the other hole on the Cart Body. Once the Axle is through the second hole, slide on a 3/4" ID x 2" Flat Washer(7), (Fig.2). Now slide on a wheel followed by a 3/4" Flat Washer(8) and then secure with a Cotter Pin(9). Repeat this for both Wheels. Use Needle Nose Pliers to bend back ends of the Cotter Pin,(Fig.3). Repeat for other side. Using 5/16" x 3/4" Hex Head Bolts(2), 5/16" Flat Washers(4), 5/16" Lock Washers(5), and 5/16" Hex Head Nuts(6) attach Clevis, (42),(on top side of Cart Body) to the Cart Body (Fig. 4). Tighten Bolts with 1/2" wrenches. Insert Clevis Pin(1) through Clevis and secure with #14 Hitch Pin Clip(3) underneath Cart Body.

Fig. 1

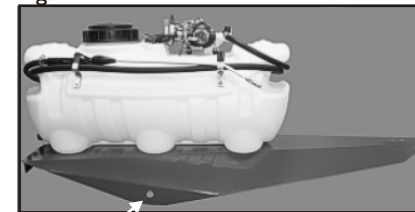

Axle Slot

Fig. 2

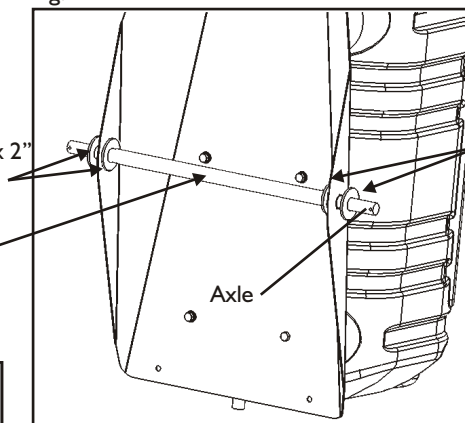

3/4" Diameter x 2" Flat Washers

Axle Spacer

Axle

3/4" Diameter x 2" Flat Washers

Fig. 3

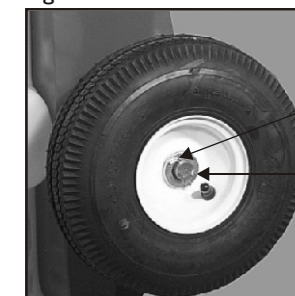

Cotter Pin

3/4" Flat Washer

Fig. 4

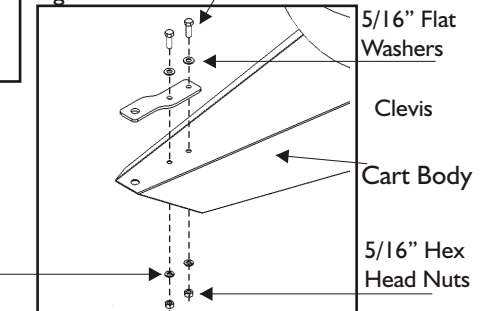

5/16" x 1" Hex Head Bolts

5/16" Flat Washers

Clevis

Cart Body

5/16" Hex Head Nuts

5/16" Lock Washers

## Assembly Instructions Continued

**STEP 2** Attach Boom Mount to Cart Body using 5/16" x 3/4" Hex Head Bolts(2), 5/16" Flat Washers(4), 5/16" Lock Washers(5) and 5/16" Hex Head Nuts (6),(Fig.5). Attach Boom Arm Assembly to Boom Mount using 5/16" x 3/4" Hex Head Bolts(2), 5/16" Flat Washers(4), 5/16" Lock Washers(5) and 5/16" Hex Head Nuts(6), (Fig. 6). Tighten all four Bolts with the 1/2" wrenches.

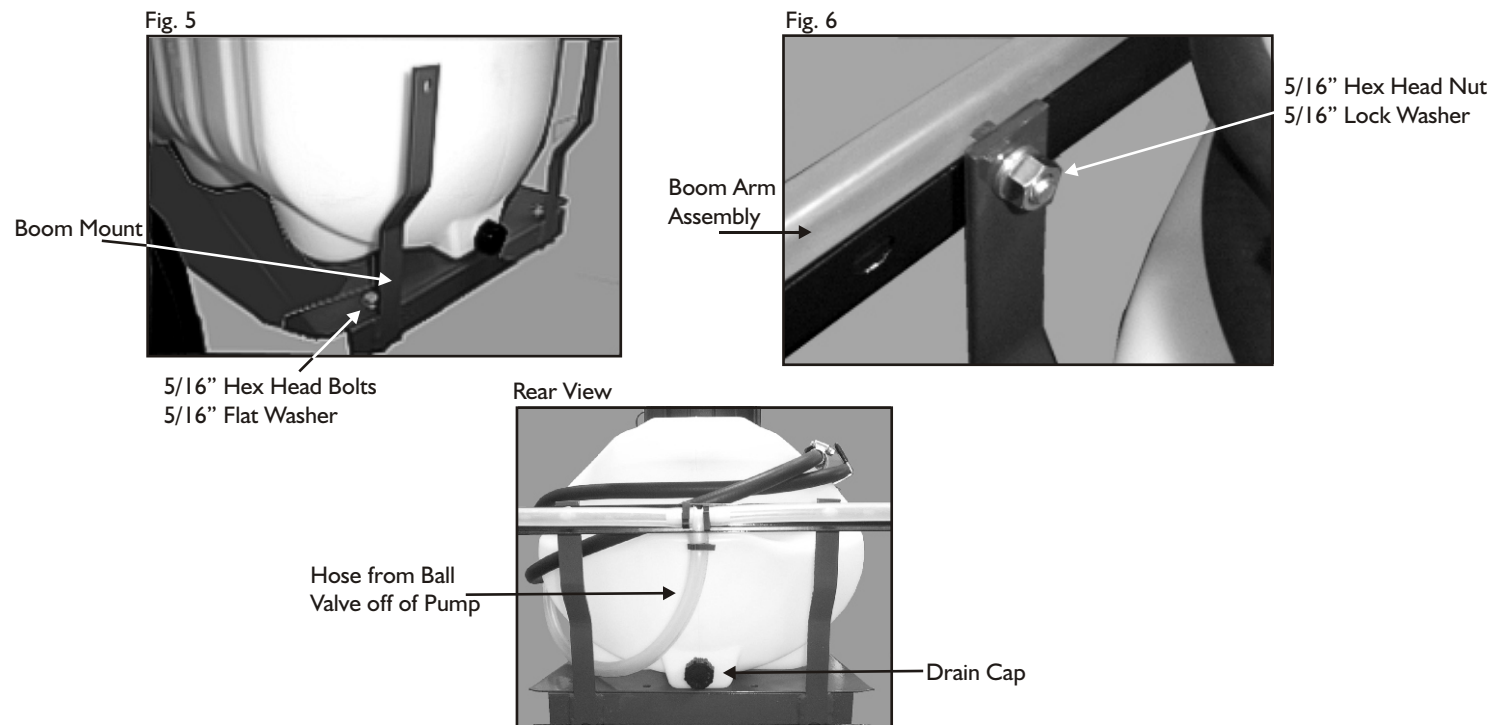

### Introduction

Your sprayer has been manufactured to provide the maximum in dependable efficient use. Proper operation and maintenance will ensure long satisfactory service. Study this manual carefully to become familiar with the operation and maintenance instructions.

Keep your manual in a safe, convenient place for future reference. Always mention the model and part number in any correspondence. To insure correct parts service be sure to use part number and description when ordering.

### Operation

Operating power is obtained from a 12 volt direct source. Be sure to connect the red to the positive (+) source and attach the black to the negative (-) source.

**IMPORTANT:** Before spraying chemicals, fill the tank full of plain water to allow familiarization with the sprayer and to prevent waste of expensive chemicals.

### Sprayer Maintenance

A sprayer is a carefully designed and built machine that should provide many years of reliable service if properly cared for. The main rule in caring for any sprayer is: **KEEP IT CLEAN.** Neglect costs dollars in repairs, wasted spray material and premature replacement of the sprayer.

### Cleaning & Storage

Most spray materials are highly corrosive. The most important aspect of long dependable service from the sprayer is a thorough cleaning immediately following each use. In addition, the residue of one type of chemical could cause an undesirable effect when a different chemical is used for a different purpose.

The most effective cleaning method is to pump several rinses of clean water through the tank, pump, hoses, boom, spray gun, etc. A neutralizing agent such as a solution of Nutra-Sol, a detergent or household ammonia as recommended by the chemical manufacturer can assist in removal of a persistent chemical. When the system is thoroughly cleaned drain the tank, suction line, pump, hoses, etc.

The following steps should be followed for the maintenance and storage of your sprayer.

1. Wash and flush out sprayer after completion of each phase of your program. Flush out sprayer when changing chemicals if there is a possibility of the chemicals being incompatible. Use of a detergent is advisable if the chemical manufacturer does not make specific cleaning recommendations. Flush system completely, including nozzles. Never use metal objects to open clogged nozzles.

2. Clean sprayer thoroughly before storing at the end of the spraying season. Permanent type anti-freeze added to the final rinse will leave a rust inhibiting film in parts of the sprayer.

## Parts List for Pump Assembly

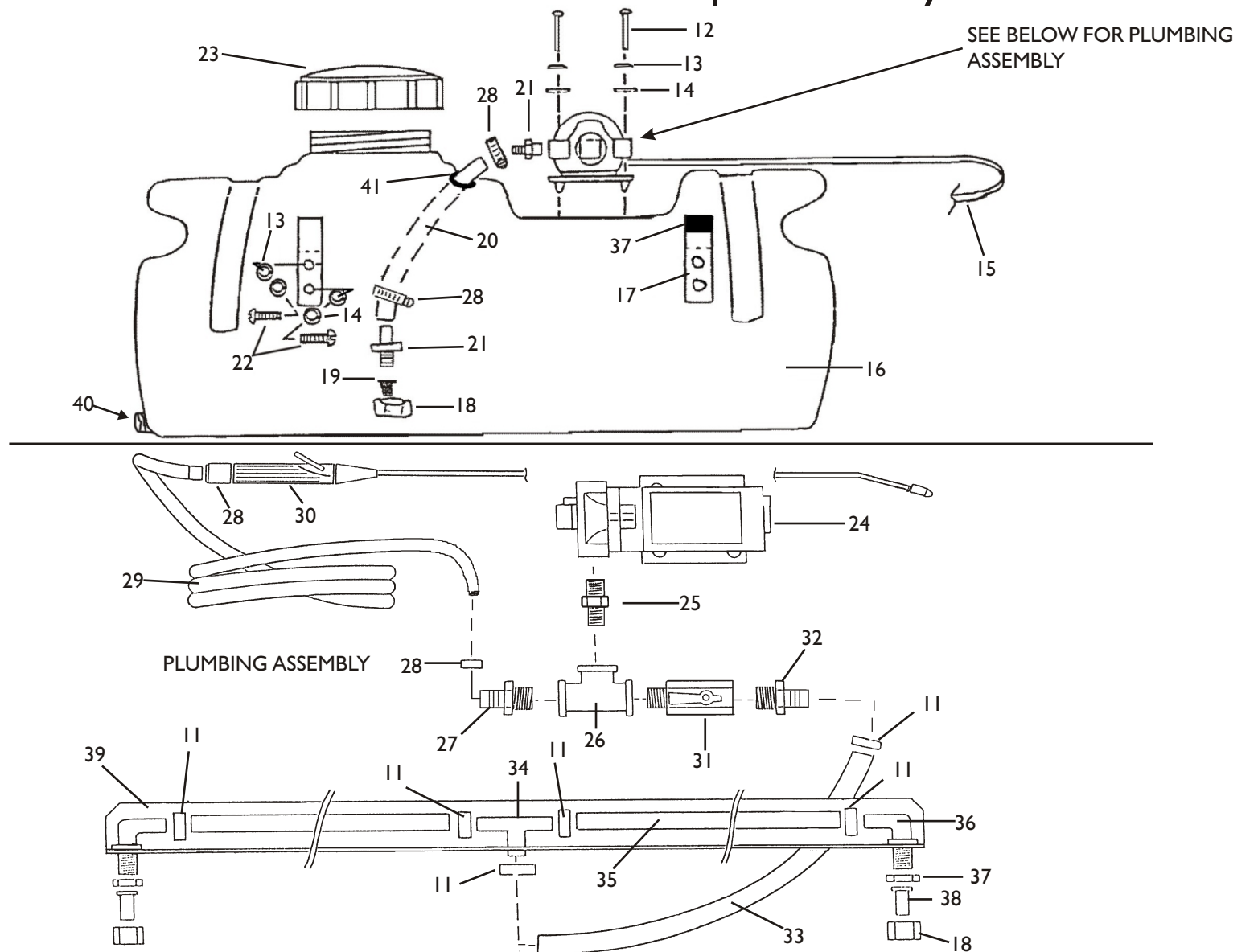

Ref.	Part Description	Part Number	Qty.	Ref.	Part Description	Part Number	Qty.
11	Hose Clamp .702 - .801 Plastic	3716	6	29	3/8 Rubber Hose 12'	3773	1
12	10-24 x 1-1/4 Round Head Screw	3604	4	30	Spray Wand & Nozzle	3658	1
13	#10 Flat Washer (10FWZP)	3605	8	31	1/4 MPT x 1/4 FPT Valve	3730	1
14	3/16" Lock Washer	2987	8	32	1/4 MPT x 1/2 HB Hose Barb	3729	1
15	Wire Harness	3665	1	33	1/2 Clear Hose 40"	3775	1
16	15 Gallon Sprayer Tank	3614	1	34	Nylon Tee, 1/2	3723	1
17	Wand Holder	3612	2	35	1/2 Clear Hose 19-1/4	3776	2
18	Nozzle Cap	3620	3	36	1 1/16 MPS x 1/2 HB ELB HB w/Nut	3725	2
19	Suction Strainer*	3619	3	37	Vinyl Cover	3638	2
20	3/8 Rubber Hose 24"	3777	1	38	Nozzle 2.5 Brown	3719	2
21	Hose Barb 3/8 MPT x 3/8 HB	3607	2	39	Boom Angle	3724B	1
22	10-24 x 1/2 Bolt	3613	4	40	Drain Cap W/Washer	3733	1
23	Tank Lid	3601	1	41	Grommet 5/8 H.D. X 3/8 Thick	3639	1
24	Pump Electric: Check Model Number						
	Models TCT15-12V (1.0 W/O Switch)	3655	1				
	Models TCT15RT-12V (1.0 W/ Switch)	3656	1				
25	3/8" MPT x 1/4" MPT Nipple	3728	1				
26	Nylon Tee, 1/4"	3718	1				
27	1/4 MPT x 3/8 HB	3731	1				
28	1/2" Stainless Steel Clamp	3632	4				

\*The strainers for boom assembly are located inside part number 39-Nylon Nozzle Fitting.

\*\*Part quantities reflect pieces assembled at factory and those in hardware sack.