

REZNOR®

Vertical Vent Terminal/Combustion Air Inlet Assembly (Option CC2)

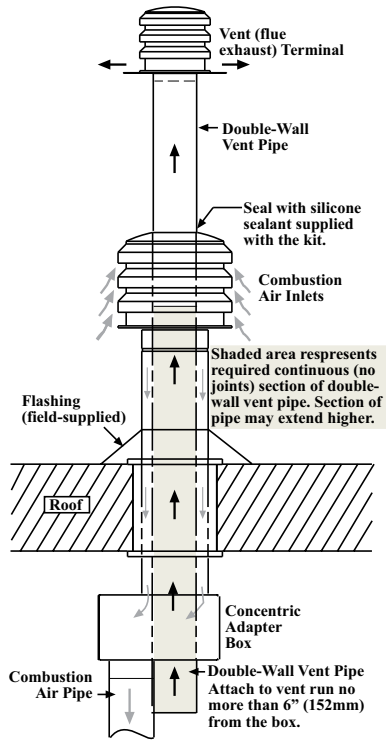

REAR VIEW

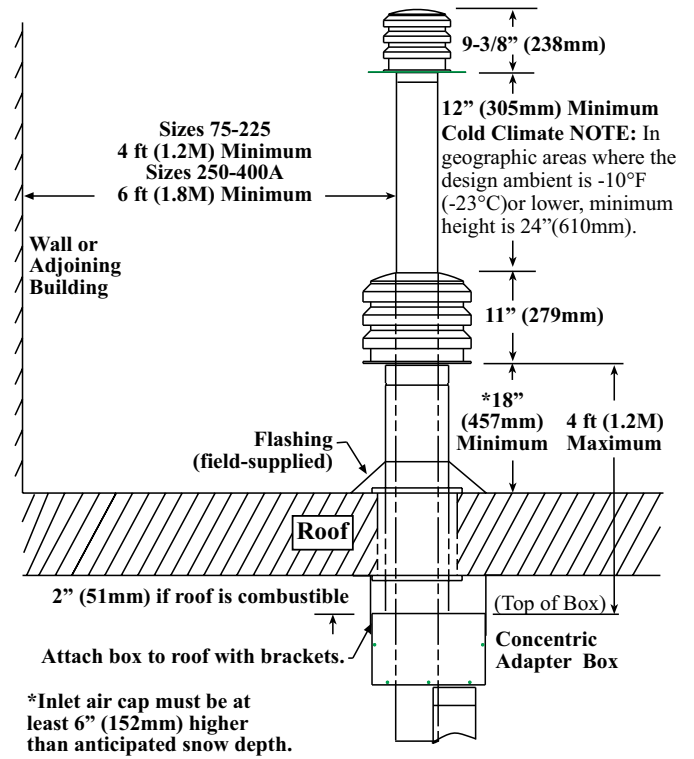

SIDE VIEW

Horizontal Vent Terminal/Combustion Air Inlet Assembly (Option CC6)

Approved vent terminals are illustrated below. No other venting arrangements are approved or certified for use with Reznor separated combustion heaters.

Both the horizontal and vertical assemblies include: concentric adapter, screened exhaust or cap, inlet ring or inlet cap, rubber gasket ring and a tube of high temperature silicone rubber sealant; all shipped separately.

TOP VIEW

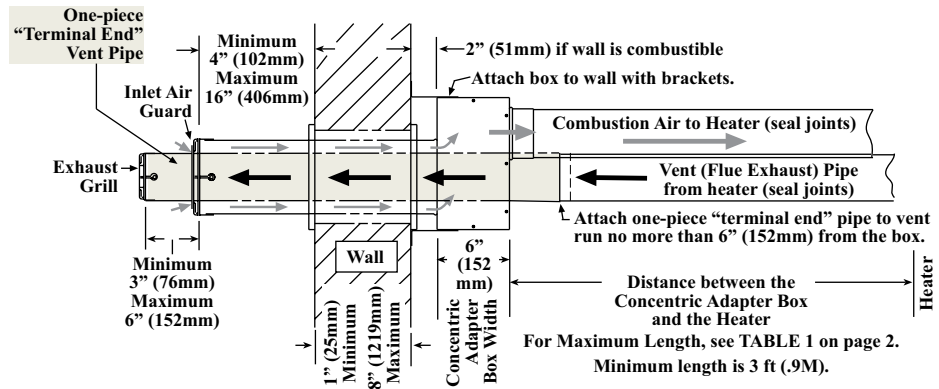

SIDE VIEW

Model SDH Sizes	X*	Y
75, 100	4 ft 1.2 M	18" 457 mm
125, 150, 175, 200, 225	4 ft 1.2 M	24" 610 mm
250, 300, 350, 400A	6 ft 1.8 M	36" 914 mm

*Minimum - Check for and comply with local Codes.

