

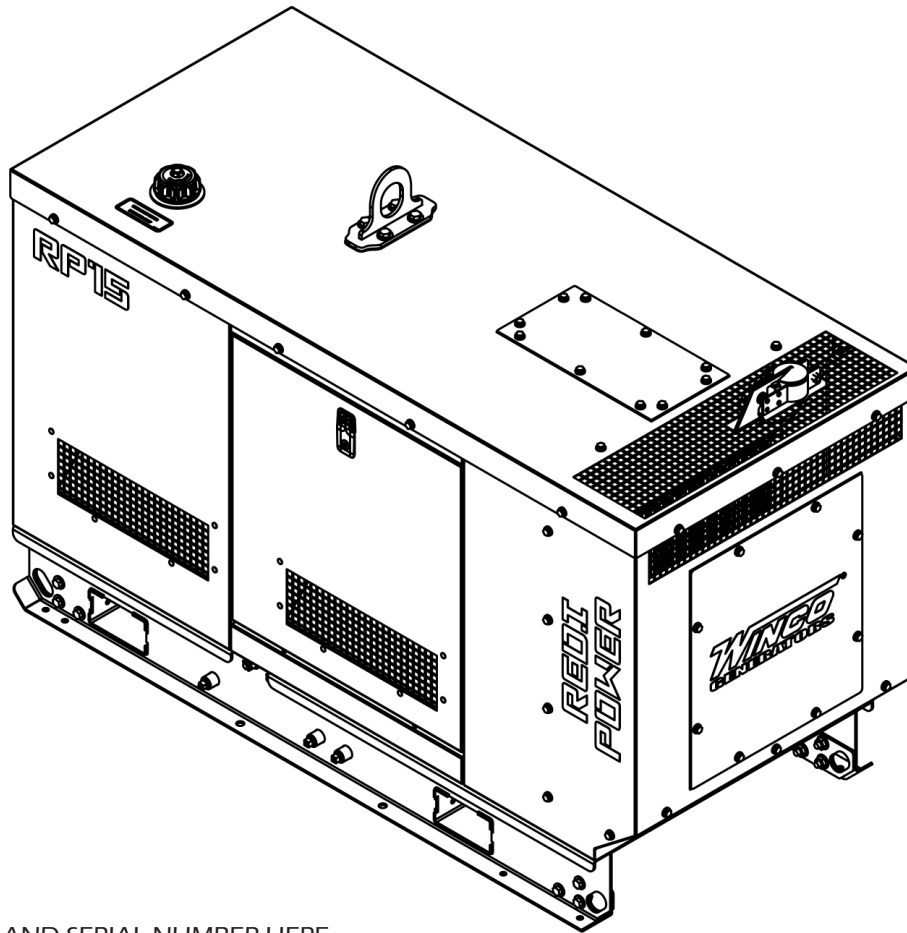

RP15Y2

INSTALLATION & OPERATORS MANUAL



COPY YOUR MODEL AND SERIAL NUMBER HERE
No other WINCO generator has the same serial number as yours.
If you should ever need to contact us on this unit, it will help us to respond to your needs faster.

MODEL _____

SERIAL NUMBER _____

PURCHASE DATE _____

DEALER NAME _____

DEALER PHONE # _____



TABLE OF CONTENTS

SAVE THESE INSTRUCTIONS	3
SAFETY INFORMATION	4
SPECIFICATIONS	5
RP15	
INTRODUCTION	6
TESTING POLICY	
PRODUCT DESCRIPTION	
PREPARING THE UNIT	7
START-UP CHECK LIST	
UNPACKING	
LIFTING THE GENERATOR SET	
INSTALLATION	8
GENERAL INFORMATION	
ENGINE GENERATOR SET MOUNTING	
VENTILATION REQUIREMENTS	
EXHAUST INSTALLATION	
FUEL INSTALLATION	
INSTALLING THE FUEL LINE	
GROUNDING	
TRANSFER SWITCH	
INSTALLING THE BATTERY	11
AC CONNECTIONS	12
RECEPTACLE PANEL	
BATTERY CHARGER	
BLOCK HEATER	
A.C. ELECTRICAL CONNECTIONS	
GROUNDING	
DC CONNECTIONS	14
DC INTERCONNECTIONS TO THE ATS	
STARTING PROCEDURE	16
INITIAL START UP	
CONNECTING THE LOADS	
CONTROL POWER	
SHUTDOWN ALARMS	
AVR WIRING	19
MAINTENANCE	20
CHECKING THE OIL	
CHANGING THE OIL	
CHANGING OIL FILTER	
CHANGE FUEL FILTER	
FILLING COOLANT	
CHANGING COOLANT	
CLEANING RADIATOR	
STORAGE	
MAINTENANCE SCHEDULE	
TROUBLESHOOTING TABLE	24
WIRING SIZE TABLE	25
RECEPTACLE WIRING DIAGRAM	26
CONTROLLER WIRING DIAGRAM	27
WIRING DIAGRAMS	28
SINGLE PHASE ZIG ZAG	
ENGINE HARNESS	29
LIMITED WARRANTY	30

SAVE THESE INSTRUCTIONS

USING THIS MANUAL

Congratulations on your choice of a WINCO generator. You have selected a high-quality, precision-engineered generator designed and tested to give you years of satisfactory service.

This manual contains important instructions that should be followed during use, installation and maintenance of the generator. Read and understand all instructions in the manual before starting and operating the generator.

To get the best performance from your new generator, it is important that you carefully read and follow the operating instructions in this manual.

Should you experience a problem please follow the "Troubleshooting Tables" near the end of this manual. The warranty listed in the manual describes what you can expect from WINCO should you need service assistance in the future.

SAFETY INFORMATION

IMPORTANT SAFETY INSTRUCTIONS

This engine generator set has been designed and manufactured to allow safe, reliable performance. Poor maintenance, improper or careless use can result in potentially deadly hazards; from electrical shock, exhaust gas asphyxiation, or fire. Please read all safety instructions carefully before installation or use. Keep these instructions handy for future reference. Take special note and follow all warnings on the unit labels and in the manuals.

SAFETY DEFINITIONS

DANGER	Indicates an imminently hazardous situation which, if not avoided, will result in death or serious injury.
WARNING	Indicates a potentially hazardous situation which, if not avoided, could result in death or serious injury.
CAUTION	Indicates a potentially hazardous situation which, if not avoided, may result in minor or moderate injury. It may also be used to alert against unsafe practices.

CALIFORNIA PROPOSITION 65



WARNING: This product contains crude oil, gasoline, diesel fuel and other petroleum products, Antifreeze to which can expose you to chemicals including toluene and benzene,

Ethylene glycol (ingested) which are known to the State of California to cause cancer, birth defects or other reproductive harm and developmental issues. For more information go to www.P65Warning.ca.gov.

DANGER: ELECTRICAL SHOCK

The output voltage present in this equipment can cause fatal electric shock. This equipment must be operated by a responsible person.

- A. Do not allow anyone to operate the generator without proper instruction.
- B. Guard against electric shock.
- C. Avoid contact with live terminals or receptacles.
- D. Use extreme care if operating this unit in rain or snow.
- E. Use only three-pronged grounded receptacles and extension cords.
- F. Be sure the unit is properly grounded for your application.

DANGER: DEADLY EXHAUST GAS

Exhaust fumes from any internal engine contain carbon monoxide, an invisible, odorless and deadly gas that must be mixed with fresh air.

- A. Operate only in well ventilated areas.
- B. Never operate indoors including attached garages
- C. Never operate the unit in such a way as to allow exhaust gases to seep back into closed rooms (i.e. through windows, walls, floors).

WARNING: FIRE HAZARD

Diesel and other fuels present a hazard of possible explosion and/or fire.

- A. Do not refuel when the engine is running or hot.
- B. Keep fuel containers out of reach of children.
- C. Do not smoke or use open flame near the generator set or fuel tank.
- D. Keep a fire extinguisher nearby and know its proper use. Fire extinguishers rated ABC by NFPA are appropriate.
- E. Store fuel only in an approved container, and only in a well ventilated area.
- F. Follow local codes for closeness to combustible material.

CAUTION: PERSONAL INJURY

The muffler becomes very hot during operation and for a period after the unit has been turned off. Do not touch the muffler until it has completely cooled off.

CAUTION: NOISE HAZARD

Excessive noise is not only tiring, but continual exposure can lead to loss of hearing.

- A. Use hearing protection when working around this equipment for long periods of time.
- B. Keep your neighbors in mind when using this equipment.

CAUTION

Keep the generator and surrounding area clean.

- A. Remove all grease, ice, snow or materials that create slippery conditions around the unit.
- B. Remove any rags or other materials that could create a potential fire hazard.
- C. Carefully clean up any gas or oil spills before starting the unit.

CAUTION

All service, including the installation or replacement of service parts, should be performed only by a qualified technician.

- A. Use only factory approved repair parts.
- B. Do not work on this equipment when fatigued.
- C. Never remove the protective guards, covers, or receptacle panels while the engine is running.
- D. Use extreme caution when working on electrical components. High output voltage from this equipment can cause serious injury or death.
- E. Always avoid hot mufflers, exhaust manifolds, and engine parts. They can cause severe burns instantly.
- F. The use of the engine-generator set must comply with all national, state, and local codes.

SPECIFICATIONS

RP15

Starting		Running	
Wattage	15,000	Wattage	12,500
kVa	15	kVa	12.5
Volts	120/240	Volts	120/240
Phase	Single	Phase	Single
PF	1.0	PF	1.0
Amps	62.5	Amps	52
Hertz	60	Hertz	60

ENGINE

Model	Yanmar 3TNM74F
Starting System	12V
Muffler	Standard
Fuel Consumption	1.31 (full load)

ENGINE FLUID SPECIFICATIONS

Fuel	ASTM D-975 -1D or 2D EN590 or equivalent
Oil Type	SEE LUBRICATION SECTION
Oil Capacity	3.59 Quarts
Cooling System	50/50 mix

GENERATOR END

NOTE: Review the Mecc Alte nameplate on your generator. Some custom applications use other models. Check the generator nameplate for actual model number. Additional generator information available on line at www.wincogen.com under Service Support.

Model	Mecc Alte NPE31-D MD35
Voltage Regulator (L-L)	SR-7/2G

INTRODUCTION

TESTING POLICY

Before any generator is shipped from the factory, it is fully checked for performance. The generator is loaded to its full capacity, and the voltage, current, and frequency are carefully checked.

Rated output of generator is based on engineering tests of typical units, and is subject to, and limited by, the temperature, altitude, fuel, and other conditions specified by the manufacturer of applicable engines.

This unit comes factory set for either auto start or manual start. With the ComAp controller used in the manual start option it is possible to wire the control for remote start. Wiring instructions can be found further in this manual. The key start version does not have this option.

PRODUCT DESCRIPTION

This engine-generator set is designed for unattended remote start operation. It can be operated as part of a fully automatic standby power system or independently as a local start unit in a prime power system. The engine-generator set is fully tested at the factory prior to shipment to insure proper operation of each individual component as well as the total system's performance and reliability.

The engine generator set consists of a multi-cylinder, liquid cooled engine nominally operating at 3600 rpm. The generator frequency regulation is maintained by the engine governor to within +/- 2.0 Hz or better with the electronic governor. The generator is a single bearing, direct drive, rotating field design. The generator is connected to the engine flywheel via flexible drive disks. The generator set is skid mounted with isolation mounts between the engine and base on all units.

A 12 Volt battery is required to complete the installation. Battery requirements are listed later under the battery installation section.

Unit Orientation Note: All references used in this manual for unit familiarization, access and component locations on the Generator Set are oriented from a TOP (plan) VIEW with engine at the FRONT and generator to the REAR.

WINCO uses a common junction box for all customer control and power connections (both AC output and DC control). The common electrical junction box is always on the left side at the generator end of the machine.

The engine is controlled and Generator Set operation is monitored for safe operation by a programmable microprocessor based electronic Engine Control Module (ECM) with an LCD digital display. The generator set ECM control is mounted on a vertical pedestal on the right side of the generator. The ECM is programmed with a cycle cranking sequence - 3 cycles of 10 seconds on/20 seconds off, and 5 minute cool-down delay. The cool-down delay can be changed in the field from 0 to 30 minutes by your installer. Other features, timing cycles, set points, and signal output capabilities are possible. Consult factory for procedure and passwords.

NOTICE

These units will automatically transfer if a power outage occurs while running in exercise mode.

GENERATOR SET

Every WINCO generator set has its own unique identity data plate. This data plate identifies the complete unit model number, the system serial number, and has links to the individual components that form the generator set in our factory records. Several of the major components also have their own individual data plates providing additional information to document build data for warranty and replacement parts.

ENGINE

Refer to the engine operators manual for more detailed operation and maintenance information.

CAUTION: EQUIPMENT DAMAGE

Be sure to check the engine oil level frequently as specified in the engine manual.

The engine manufacturer has established an excellent worldwide engine service organization; engine service is available from a nearby authorized dealer or distributor. Go to the WINCO website for a list of engine dealers or contact the WINCO Service Department.

The rated power of each engine-generator is limited by the temperature, altitude, and all other ambient conditions specified by the engine manufacturer. Engine power may decrease 10% at 6,531 feet above sea level. Units should not be operated in ambient temperature greater than 122° Fahrenheit.

GENERATOR

WINCO generator sets use brushless, AVR (Auto-Voltage Regulator) controlled broad-range generator ends. The generator converts rotational mechanical energy into electrical energy. These WINCO units are equipped with generators manufactured by Mecc Alte. Each generator 'end' has its own data tag. A unique serial number is on the data plate.

PREPARING THE UNIT

START-UP CHECK LIST

A Start-Up Completion & Warranty Validation Form was sent along with this manual. This must be completed and returned to WINCO Inc. within 180 days of the factory invoice date. If this form is not returned, the Warranty may be voided.

UNPACKING

1. As you receive your unit, it is critical to check it for any damage and annotate it on the BOL. If damage is noted, contact WINCO for assistance in getting the generator repaired.
2. Before proceeding with the preparations of your new generator for operation, take a couple of minutes to ensure the unit you have received is the correct model and review the specification pages in this manual to ensure that this unit meets your job requirements.

CAUTION: EQUIPMENT DAMAGE

This unit is shipped with oil and a 50/50 mix of coolant. Be sure to check all fluid levels before operating. See engine manufacturer's instruction manual for recommended oil requirements before initial starting.

Once generator set is on-site:

After inspecting the engine-generator for external, physical damage, locate and check the following items packed with the unit:

- a. Installation and Operator's Manual.
- b. Engine manufacturer's instruction manual.
- c. Battery hold-down brackets & hardware.
- d. Unit components or accessory items shipped loose for on-site installation.
- e. Optional accessories.

LIFTING THE GENERATOR SET

1. Make sure that the area under the equipment is kept clear.
2. Be certain rigging is designed to lift unit safely.
3. Never attempt to lift the unit unless you are certain the lifting device has sufficient capacity.
4. Never allow the unit to swing while suspended.
5. Be certain the supporting structure is adequate to handle the weight of the unit.

CAUTION

Only lift the unit using the factory installed lifting eye, located on top of the unit's housing.

CAUTION:

Do not attempt to lift the generator set by the means of the lifting eyes on the engine or generator end. These lifting points are only for the use during the manufacturing process and are designed for lifting of the individual generator set components and not the complete unit.

INSTALLATION

The max ambient temperature is 104°F. For derating information, see specification sheet. This unit should be installed in a well ventilated area, ensuring the exhaust air cannot be recirculated back into the engine.

CAUTION

This unit will get hot while it is running and for some time afterward.

WARNING: PERSONAL INJURY

Before proceeding with the installation, be sure the engine control is in the "stop" position and the emergency stop depressed. Also, be sure the generator MLCB (main line circuit breaker) is in the "off" position and the unit starting battery is disconnected

GENERAL INFORMATION

This engine-generator set can be supplied as weather enclosed. Consult a qualified, licensed electrician or contractor to install and wire the gen-set. The installation must comply with all national, state, and local codes. The factory weather enclosures are acoustical housing intended for outdoor use only. Units are not intended to be used indoors and no support is available to assist in re-engineering finished packaged units.

Before beginning the installation process, recheck the voltage, phase, and amperage rating of the generator set. Be certain it can handle the intended load and are compatible with the intended loads. Plans for installation should be prepared with proper attention to mechanical and electrical engineering detail to assure a satisfactory system installation.

The information in this manual is offered only as a guide to finalizing your installation plans and does not substitute for sound engineering judgment for the specific application.

NOTICE

For full service switching of the entire load, the ATS must be 'SE' (Service Entrance) rated or must have a properly rated fusible disconnect installed before the ATS to protect the contacts.

ENGINE GENERATOR SET MOUNTING

The unit's main frame must be securely anchored to a solid base. The engine-generator is mounted on channels which are attached with special shock mounts to the main frame. This allows the engine-generator free movement without affecting the base or surrounding equipment.

WARNING: EQUIPMENT DAMAGE

Never mount these engine-generator sets to a wooden base/structure. Over time, the wood will deteriorate and the unit mountings will come loose. These units must be mounted to a steel or concrete base.

The unit should be mounted to allow ample working room OPM-173/A

around it. A general rule to follow is to allow 24 inches or more of clearance for maintenance. Follow local codes for clearance from combustible surfaces.

VENTILATION REQUIREMENTS

OPEN SKID

WARNING: EQUIPMENT DAMAGE

It is the installer's responsibility to ensure that there is sufficient cooling air available to prevent the engine and generator from over heating. Damage caused by overheating is not covered by warranty.

Providing proper air movement during your installation planning is essential. You will need to provide a fresh air inlet as well as a hot air outlet (to the outside of protection housing) for proper engine performance. These engine-generator sets are equipped with unit mount radiators and the engine is equipped with a pusher type fan. The hot air from the face of the radiator must be ducted out of the enclosure to ensure proper cooling. Failing to do so will allow the hot air to recirculate around the radiator causing the engine to overheat, resulting in an engine shutdown and damage. If louvers are used in front of the hot air duct to protect the unit from outside weather, the louvers should be 1 1/2 times as large as the area of the radiator face to prevent back pressure.

Foam or other seals can be used to form a tight lip forcing all of the air from the engine fan out of the enclosure. In addition to a hot air discharge, you must plan a fresh air intake opposite the radiator discharge.

WARNING: EQUIPMENT DAMAGE

Failure to seal the radiator output will result in hot air recirculation that will result in equipment overheating and damage. Their fresh air inlets should be 1 1/2 to 2 times larger than the radiator face. The extra air inlet area is required to minimize restriction and to provide combustion air for the engine. Do not block fresh air intakes with other equipment as this will result in insufficient air flow to the engine for cooling. Installing them opposite the hot air discharge will allow a sweeping flow of cooling air across the engine, preventing hot spots.

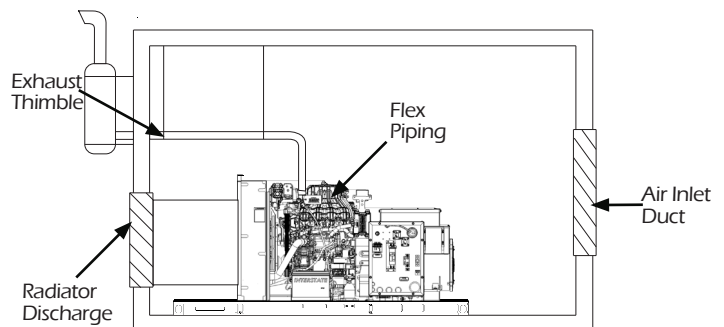

The WINCO installation manual OPM-112 contains additional information on indoor, open skid installations and is available electronically through our website or by requesting a copy from the factory.

EXHAUST INSTALLATION

WARNING: PERSONAL INJURY

Improper exhaust installation will allow dangerous gases to seep into enclosed spaces causing a hazard to your health and/or death.

All exhaust must be piped out of the enclosure. When selecting a location to exhaust fumes make sure that the potential for contact with people is controlled. Exhaust can enter buildings through windows, ventilation systems and other openings if proper precautions are not followed.

The exhaust must be isolated from the vibration of the engine. If the exhaust is connected in a rigid system it will result in damage to the engine. The generator comes equipped with an engine mounted flex pipe to aid your installation. Ensure proper alignment with the generator. The flex can be eliminated if it is pushed to one side to make a connection.

The most direct path possible should be used to get to the outside of the enclosure. Each bend restricts the pipe and increases back pressure. It may be necessary to increase the exhaust pipe diameter in some applications.

The exhaust pipe is very hot. When passing through the structure it is critical that a thimble or other appropriate technique is used to dissipate the heat and prevent the structure from catching on fire.

It is preferable to exhaust out the side of the enclosures. Slope the pipe slightly downward away from the engine to cause any water in the exhaust to run away from the engine. Do not exhaust near intake. Once outside the enclosure a rain cap or other technique must be used to keep water out of the exhaust. In mobile applications make sure the rain flap faces to the rear of the vehicle so that it is not blown open during transportation.

The generator ships with a critical grade muffler that should be installed to decrease noise. It can be mounted either internally or externally to the enclosure. The muffler cannot increase back pressure to more than 0.725 psi.

FUEL INSTALLATION

The fuel supply should be as close as possible to the engine. This will reduce the installation cost of fuel runs. The information in this manual is offered to assist you in providing the proper fuel for your engine. However, this information is only provided to inform you of the engine's requirements and assist in making you aware of the decisions you must make. In no case should the instructions and information provided be interpreted to conflict with any local, state or national codes. If in doubt, always consult your local fire marshal, gas supplier or building inspector.

WARNING: FIRE HAZARD

All fuel runs should be installed by a licensed fuel supplier.

In no case should the instructions or information provided be interpreted to conflict with any local, state, or national codes. If in doubt, always consult your local fire marshal or fuel supplier.

INSTALLING THE FUEL LINE

WARNING: FIRE DANGER

Connecting rigid fuel line (i.e. steel or copper line) directly to the inlet fuel filter or fuel pump may cause the fuel line to crack during operation creating a serious fire hazard.

The fuel supply should be as close to the engine as possible. This will reduce the installation cost of fuel runs and minimize line losses. The diesel fuel supply should be no more than 3 feet below the fuel inlet on the pump. If your fuel supply is lower than three feet you may have to install an additional lift pump to bring the fuel up to the mechanical fuel pump on the engine.

The information in this manual is offered to assist you in providing the proper fuel for your engine. However, this information is only provided to inform you of the engine's requirements and assist in making you aware of the decisions you must make. In no case should the instructions or information provided be interpreted to conflict with any local, state, or national codes. If in doubt, always consult your local fire marshal or fuel supplier.

Engine generator sets are properly adjusted before they leave the factory. Connecting a fuel supply with adequate supply volume is critical to reliable operation. Diesel units with optional base mounted fuel tanks are pre-plumbed to the mechanical fuel pump on the engine.

Open skid mounted diesel units are often supplied with capped inlet and return lines. The use of a sustainable customer supplied flexible fuel line is essential between the engine and fuel supply to provide a vibration break between your fuel supply and the engine.

GROUNDING

Proper grounding of your generator is application dependent. Carefully evaluate your planned use of your generator to understand which grounding you require. If you are not sure what to do, contact a competent professional to assist you. The NFPA 70 250:34-35 are good technical references.

VEHICLE-MOUNTED GENERATOR

Your WINCO generator ships with a bonded neutral. When mounted to a vehicle to safely distribute power it is necessary that the generator frame is bonded to the vehicle frame. The generator should only supply equipment that is cord and plug connected through customer installed receptacles mounted on the generator or the vehicle.

PERMANENTLY INSTALLED GENERATORS

This WINCO portable generator ships with a bonded neutral. NFPA 70 refers to this as a "separately derived system." When connecting it to a building a transfer switch specifically designed for GFCI and bonded neutral generators is required or the ground or the neutral to ground bond must be broken and the panel relabeled.

TRANSFER SWITCH

NOTICE:

For full service switching of the entire load, the ATS must be 'SE' (Service Entrance) rated or must have a properly rated fusible disconnect installed before the ATS to protect the contacts.

WARNING: FIRE HAZARD

All wiring must be done by a licensed electrician, and must conform to the National Electrical Code and comply with all the local codes and regulations. Check with the local authorities before proceeding.

For standby applications, an automatic transfer switch (ATS) will be necessary for automatic starting. A wall mounted ASCO 300 ATS designed for inside or outside installation. The transfer switch is UL1008 approved. A fourteen day electronic exerciser circuit is installed in the ATS as standard equipment. The ATS also contains the power failure sensing circuitry necessary to start and stop the engine generator set. The transfer switch is also equipped standard with a 3 second start delay, and a 15 second transfer delay to allow the engine to warm up before transferring the load to the generator. When the line power is restored the ATS has a 5 minute transfer delay to allow the incoming utility to stabilize before transferring back to line power and then an additional 1 minute engine cool down delay before the engine shuts down. Read and understand the ATS owners manual before installing, servicing or operating the transfer switch.

INSTALLATION NOTES

Because of many different types of service, feeder and distribution equipment, no specific wiring instructions can be provided. It is recommended that only copper wire be used. In all cases it is essential that while the load is connected to the generator, there can be absolutely no feedback from the generator to the power line or the power line to the generator. When properly installed, the normal ATS Control and safety system will eliminate all paths and feedback.

To wire the automatic transfer switch into existing wiring, first determine which circuits will be on the emergency load circuit. If the entire load is transferred, the transfer switch can be wired directly after the watt-hour meter and the service entrance, providing the service entrance ampere rating is within the transfer switch's rated capability.

If only specific circuits are to be powered under emergency power failure conditions, an additional distribution panel designated "emergency distribution panel" must be installed.

All selected emergency circuits are removed from main distribution panels and installed in the emergency distribution panel. The ATS is then installed between the main panel and the emergency distribution panel. Suggested circuits: freezer, refrigerator, furnace, emergency lights, sump pump, emergency outlet circuits, etc. Total running load must not exceed generator rating.

INSTALLING THE BATTERY

CAUTION

In the following battery installation procedure, check to be sure the ComAp IntelliNano is in the “stop” position. This should be your last step before initial start-up.

The RP15 is a 12 volt system and requires a single battery. The batteries should be rated at a minimum of 500 CCA. Installation of the highest CCA rated battery, within the correct BCI group, will increase cold weather starting performance. Gel batteries should not be used with the battery tender installed in the generator enclosure.

Installation and servicing of batteries must only be performed or supervised by personnel knowledgeable of batteries and the required precautions. Keep unauthorized personnel away from batteries.

When installing or replacing batteries, use the proper group/size starting battery. The battery should be a maintenance-free lead acid design. Deep cycle batteries will not work for this application.

CAUTION: PERSONAL DANGER

NEVER dispose a battery in a fire. The battery is capable of exploding.
DO NOT open or mutilate the battery. Released electrolyte is known to be harmful to the skin and eyes and to be very toxic.
These engine-generator sets are all **NEGATIVE** ground. Be very careful not to connect the battery in reverse polarity, as this may short circuit the battery charging system on the engine.

CAUTION

A battery presents a risk of electrical shock and high short circuit current. The following precautions must be observed when working with batteries:

1. Remove watches, rings, and other metal objects.
2. Use tools with insulated handles.
3. Check both the battery cable ends and the battery posts to be sure they are free of corrosion.
4. Always connect the battery positive cable first and then connect the battery negative cable. When removing the battery cables from the battery, reverse the procedure, disconnect the negative first and then the positive cable.
5. Be sure all connections are tight and coat the terminals and cable ends with dielectric grease.

WARNING

The electrolyte is diluted sulfuric acid that is harmful to the skin and eyes. It is electrically conductive and corrosive. The following precautions must always be taken.

1. Always wear full eye protection and protective clothing.
2. Where electrolyte contacts skin, wash off immediately with water.
3. If electrolyte contacts the eyes, flush thoroughly and immediately with water and seek immediate medical attention
4. Spilled electrolyte is to be washed down with an acid neutralizing agent. A common practice is to use a solution of one pound of bicarbonate of soda (baking soda) to one gallon of water. The bicarbonate of soda solution is to be added until the evidence of reaction (foaming) has ceased. The resulting liquid is to be flushed with water and the area dried.

DANGER: EXPLOSIVE FIRE RISK

1. Never smoke when near batteries.
2. Do not cause a flame or spark in the battery area.
3. Always discharge static electricity from your body before touching batteries by first touching a ground metal surface.

SERVICING BATTERIES

Batteries used on these units may, over time, lose water. This is especially true if you are using a trickle charger to maintain your battery. Different types of batteries require various types of maintenance. Refer to the battery manufacturer for specific recommendations.

NOTE: Always make sure that a new battery is fully charged before installing it on a generator set. Failure to do so can cause damage to the engine control module in the generator set.

All connections must be clean and tight. Depending on your battery type, check the electrolyte in the battery periodically to be sure it is above the plates. Never allow the battery to remain in a discharged condition.

CAUTION: EQUIPMENT DAMAGE

Never attempt to jump start this engine. If the battery should accidentally become discharged, disconnect the battery cables and recharge the battery before attempting to start the unit. Boost/jump starting this unit improperly will result in **PERMANENT DAMAGE TO THE ENGINE CONTROL MODULE (ECM)**.

BATTERY CHARGER

An optional three-stage, 1.5 amp, electronic battery charger is provided standard on this unit. This charger has three rates of charging. During the first mode, known as Bulk charging, the charging current is limited to 2 Amps at a voltage of up to 14.5 VDC. The green LED will blink during this stage. During the Absorption mode, the charger holds the battery voltage at approximately 14.5 VDC, and then gradually reduces the amount of Amps it delivers to the battery. This way the battery is able to “absorb” the last 10% of charge as quickly as possible without becoming overheated. The green LED will blink during this stage. When the battery approaches full charge, the charger switches into its third charging stage, gradually reducing the current fed to the batteries to as low as 0.1 Amps. At the same time, it reduces its output to a “Float” or “Maintenance” charging rate of approximately 13.3 VDC nominal, indicated by the green LED. This low “Float” or “Maintenance” voltage gently “tops off” the battery, keeping it fully charged and ready until needed. The green LED will indicate the battery is fully charged.

OPTIONAL SOLAR CHARGER

The WINCO solar option consists of two parts; the solar panel and the Sun Guard charge controller. The solar panel collects the energy while the Sun Guard controls the charging process acting as a switch to prevent the solar panel from discharging or overcharging the battery. If you are experiencing problems with your solar charging system contact WINCO service for trouble shooting instructions.

For best results, it is necessary to clean the solar panel surface from dirt and snow build up.

BLOCK HEATER

The optional block heater on this unit is 1000 watts and should also be plugged in the Shore Power receptacle. The block heater is thermostatically controlled and when plugged in will maintain the engine coolant temperature between 100 and 120 degrees F.

AC CONNECTIONS

NOTICE: CLASS 1 WIRING METHODS ARE TO BE USED FOR ALL FIELD WIRING CONNECTIONS TO TERMINALS OF A CLASS 2 CIRCUIT

All wiring must be completed in accordance with the National Electric Code as well as any state and local codes.

You must pay particular attention to wire size requirement for the amperage of service you are dealing with. The table below provides you guidance on wire sizing based on both wire type and amperage. **Wire amperages have been derated for 40° C ambient temperatures operation.**

WARNING

Make sure the generator is disconnected from the battery to prevent accidental starting.

RECEPTACLE PANEL

(If equipped)

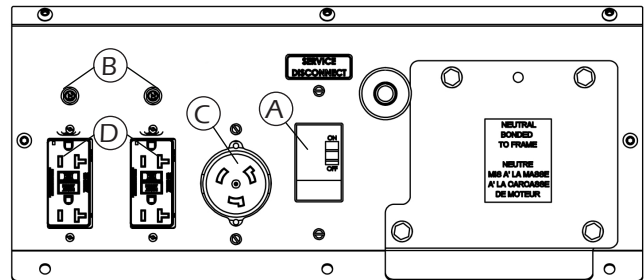

WARNING: PERSONAL DANGER

Verify the main line circuit breaker and battery are disconnected before making connections. Failure could result in electrocution, which can result in serious injury or death.

A: 120/240 60A Circuit Breaker

These circuit breakers protect the 1 - 50 amp twistlock receptacles (C).

B: 120/240 20A Circuit Breaker

These two push button 20 amp circuit breakers protect the two GFCI receptacles (D).

C: 125/250 50A Receptacle

This receptacle is rated for dual voltage, 120 or 240V use. It is a 4-wire receptacle, with a center grounding pin. 4-wire drop cords plugged into this receptacle may be split into 120V receptacles at a distribution box. It is protected by a two pole 60 amp circuit breaker. THIS RECEPTACLE UTILIZES A HUBBELL PLUG PART # CS6365.

D: 120/240 20A Receptacles

These duplex receptacles are protected by 20 amp circuit breakers mounted just above the duplexes. The “T” slot design both 15 and 20 amp 120V cords can be plugged in.

WARNING

A mainline circuit breaker has been provided inside the generator housing. During all wiring installations, make sure the breaker is in the OFF position and the generator operating switch is in the OFF position.

A.C. ELECTRICAL CONNECTIONS

WARNING

Wiring and connections to unit should be performed by a competent technician. Improper installation could result in electrocution, which could cause equipment damage, serious injury or death.

Access for routing the wires into the terminal block is provided via the access door located in the back of the unit. The top panel will hinge open once unscrewed.

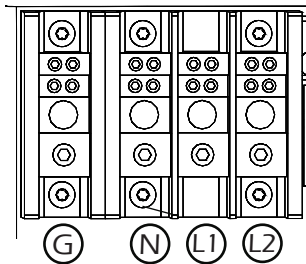

NOTE: The neutral is bonded to ground. This connection can be found in the circuit breaker panel.

NEUTRAL LUGS:

These lugs are bonded to ground and provided for you to connect your neutral wire from the transfer switch to the generator. Lugs will handle up to 4 AWG wire. Torque lugs to 375 in. lbs.

GROUND LUG:

These ground lugs are bonded to neutral and are provided for you to connect your ground wire from the transfer switch to. The lugs will accommodate up to 4 AWG wire. Torque lugs to 375 in. lbs.

L1 & L2 POWER OUTPUT LUGS:

The full power terminal block is capable of handling full generator output. Lugs will handle up to 4 AWG wire. Torque lugs to 375 in. lbs.

WARNING

Wiring and connections to unit should be performed by a competent technician. Improper installation could result in electrocution, which could cause equipment damage, serious injury or death.

GROUNDING

Proper grounding of your generator is application dependent. Carefully evaluate your planned use of your generator to understand which grounding you require. If you are not sure what to do, contact a competent professional to assist you. The NFPA 70 250:34-35 are good technical references.

PERMANENTLY INSTALLED GENERATORS

This WINCO portable generator ships with a bonded neutral and overcurrent protection. NFPA 70 refers to this as a "separately derived system." When connecting it to a building a transfer switch specifically designed for GFCI and bonded neutral generators is required.

A competent technician can change the neutral configuration to match the application by following NEC wiring and ground labeling principles.

DC CONNECTIONS

All DC connections are completed on the terminal strip just below the engine control. All DC connection must be separate conduit. You cannot mix AC and DC leads at the same conduit.

To install the wires, reference the following picture. Use a small flat head screwdriver to push the release spring inside the square hole (A). While the release is being pushed, insert the wire into the larger circular hole (B). Remove the screwdriver to secure the wire into place.

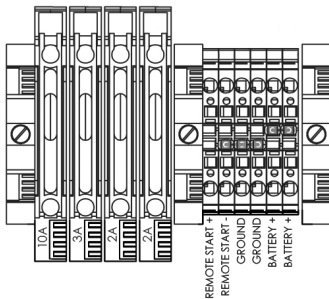
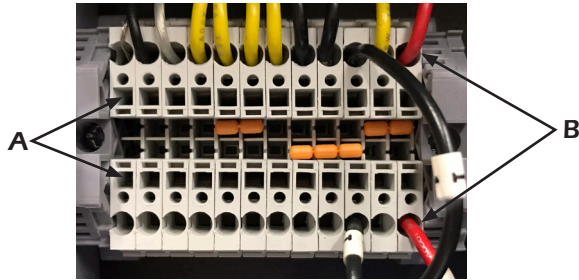

The E-Stop and Remote Start wires have been wired from the controller terminals to the panel for easy installation.

REMOTE START

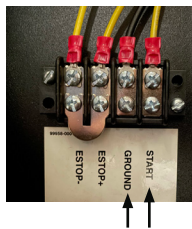

The two remote start leads from the Automatic Transfer Switch are connected to the two terminals marked GROUND & START. The WIRE in terminal GROUND is battery negative and the wire in the terminal labeled START is your remote start lead. Closing these two leads together will signal the ComAp to go into an autostart mode and start up the generator.

Depending on the distance, 14 to 16 gauge standard wire should be used. It is suggested that these wires be labeled S1 (ground) and S2 (start). The terminal blocks are designed to use terminal lugs on all wires and the screws should be torqued to 9.6 in. lbs.

Note: Any relay closure can be used to start and stop this generator. As long as the contact stays closed, the generator set will continue to run. Once the relay is opened, the unit will shut down and remain on standby mode until the remote start relay is closed again.

E STOPS

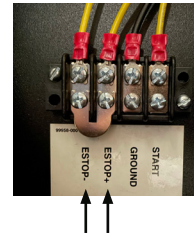

In some applications additional emergency stops may be desired or necessary. The controller has terminals designed allowing the addition of multiple remote emergency stops. E-stops must be normally closed to work properly in this system. The e-stop circuit supplies power to the fuel solenoid and the starter circuit. Opening any switch in the series prevents the engine from cranking or from receiving fuel to run.

To wire additional emergency stop switches first remove the orange jumper between the two Emergency Stop terminal blocks. Failure to remove the jumper will prevent the remote switches from working properly. Add wires between the terminal block to the new switch(s). The switches must be wired in series for proper function. Test each e-stop after wiring to ensure they function properly.

DC INTERCONNECTIONS TO THE ATS

WARNING

Use a properly installed transfer switches when isolating the generator set from utility power. Failure to do so could result in backfeeding, which is illegal and dangerous. Backfeeding can cause serious injury or death.

WARNING

Be sure Engine/Generator is in the OFF position before you make any DC interconnections.

CAUTION

Never run the AC and DC wiring in the same conduit.

ASCO 185 UL SWITCH

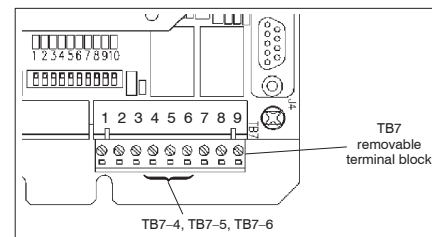

TB7 Generator starting contact terminals

Table A. Generator Start Connections

When the Utility fails	Terminals on Controller
contact closes	TB7-4 and TB7-5
contact opens	TB7-5 and TB7-6

ASCO 300 UL SWITCH



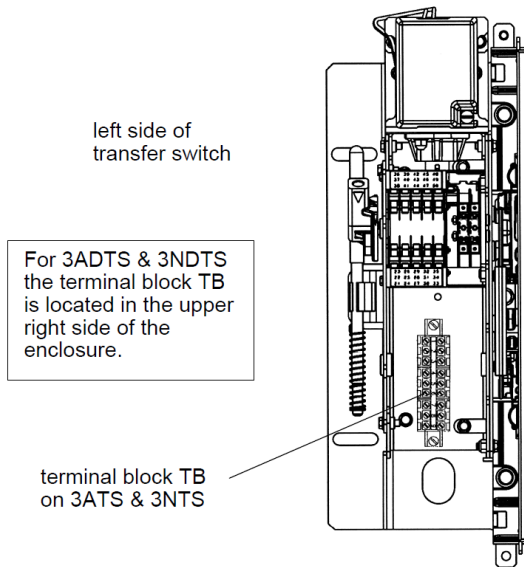

When Normal Source Fails	Terminals On Transfer Switch
Contact Closes	TB1 and TB2
Contact Opens	TB1 and TB3

Engine start and auxiliary circuit terminal block TB located on 3ATS & 3NTS transfer switch.

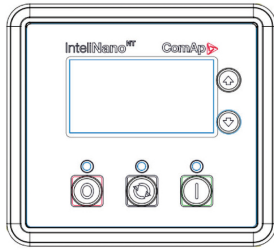

STARTING PROCEDURE



	<p>STOP/RESET - This button places the module into its Stop/Reset mode. This will clear any alarm conditions for which the triggering criteria have been removed. The fuel supply de-energizes and the engine comes to a standstill. Should a remote start signal be present while operating in this mode, a remote start WILL NOT occur.</p>
	<p>START - Pressing this button from STOP/RESET will start the engine and run the load.</p>
	<p>AUTO MODE - This button places the module into its Auto Mode. This mode allows the module to control the function of the generator automatically.</p>
	<p>MENU NAVIGATION - Used for navigating the instrumentation, event log, and configuration screens.</p>

PROTECTIONS

When an alarm is present, the common alarm, if configured, will illuminate. The LCD display will show an icon to indicate the failure.

WARNINGS

Warnings are non-critical alarm conditions and do not affect the operation of the generator system, they serve to draw the operator's attention to an undesirable condition. Warning alarms are self-resetting when the fault condition is removed. The icon will appear steady in the display.

SHUTDOWN

Shutdowns are critical alarm conditions that stop the engine and draw the operator's attention to an undesirable condition. Shutdown alarms are latching. The fault must be removed and the STOP/RESET button pressed to reset the module. The icon will be flashing in the display.

INITIAL START UP

WARNING: EQUIPMENT DAMAGE

Before attempting to start this unit, complete your pre-start checklist and ensure the generator mainline circuit breaker is in the proper position prior to starting. Starting this unit without it properly connected can cause serious personal injury or equipment damage.

DO NOT jump start these engine-generator sets. Starting these units on a low battery or jump starting them will cause damage to the engine control module.

Use the following check list to verify correct installation before starting the engine.

- Engine oil. Fill as required with proper grade/qty.
- Engine coolant. Fill as required with proper mixture.
- Unit mounting base properly bolted down.
- Clearance for service and maintenance on all sides.
- Proper fuel line material and size.
- All fuel line connections tight.
- Battery connections clean and tight
- Battery fully charged.
- All AC and DC wiring installed and properly protected.

After completing the previous checklist, the engine-generator set is ready for initial start-up.

MANUAL MODE

1. Select the desired voltage with the selector switch.
2. Turn off the main line circuit breaker.
3. Press and release the MANUAL MODE button. The small LED light next to it should come on.
4. Press and release the green START ENGINE button. The controller will send a start signal to the glow plug solenoid on the engine. Preheating the engine for about 10 seconds at the end of that time will engage the fuel rack solenoid and the starter. This will start the cranking cycle (10 seconds on and 10 seconds off).

Note: There is no start delay in this mode of operation.

If the engine fails to start during this cranking period, the starter motor is disengaged and goes into a rest mode after which a second attempt is made to start the engine. Should this sequence continue through 3 cranking cycles the start sequence will be stopped and the display will show a Start Fail icon.

All engine functions are controlled by the controller. Once the unit is running, the control will display the engine information, To get the generator information, use the navigation arrows on the controller.

The AC output readings displayed on the are collected through the AC interface harness wired in the generator control box. Any shutdowns related to the AC output are a function of the controller are based on information collected in the controller via this AC harness.

5. After the engine is running at the proper speed, adjust the voltage to the desired level using the external voltage trim rheostat.

6. Turn on the proper main line breaker (either high or low voltage) and padlock the lock bar to prevent the incorrect breaker from being turned on.

WARNING: EQUIPMENT DAMAGE

Never apply a load to the generator until you have first checked the voltage at the terminal blocks.

7. With the engine running smoothly check the no load voltage and frequency on the digital display. The voltage should be 240AC and a frequency of 59.5 to 60.5 hertz (Hz).

If you have the proper voltage at the generator the next step is to check the voltage at the generator terminals. The voltage between the L1 and L2 terminals should be the same as it was on the generator front panel. The voltage should also be checked between the hot terminals (L1, L2) and the N to be certain of a balanced voltage output and a solid neutral connection.

NOTICE

If for any reason during the check out procedure the voltage and frequency are not correct, depress the STOP/RESET button and correct the trouble before proceeding.

8. Stopping - In manual mode, pressing the STOP/RESET button will stop the unit but only after the cool down timers have timed out and there is no remote start signal being sent to the unit. Pressing the STOP/RESET button a second time will shut down immediately.

In the event of an emergency, the E-Stop can be pushed.

WARNING: EQUIPMENT DAMAGE

Stopping the generator without sufficient cool-down time, can result in premature wear and cause damage to engine components. The EStop and override shutdowns should only be used in the event of an emergency.

AUTO MODE

To activate the automatic start mode you will just need to depress the AUTO button, the LED indicator beside the button confirms that the unit is in automatic mode.

To test the Automatic Transfer Switch, follow the instruction on the operator's manual that came with the transfer switch. If you get a fault during the initial start up or prior to start up, it is most likely a false warning light. Simply reset the ATS and start over.

Once you have completed testing of the ATS, be sure you ALWAYS leave the system in the standby mode, unless servicing the unit. For standby operation, press the AUTO button on the front of the control. The green light should light up next to the AUTO button.

NOTE: For setting the exerciser circuit, for all ATS, see the operator's manual shipped with the ATS.

CONNECTING THE LOADS

WARNING

All wiring must be done in accordance with National Electric Code NFPA 70.

There are two ways the loads may be connected to the







1. Receptacle Panel -
A variety of receptacles have been provided for your convenience .
2. Full Power Load Connection Terminal Block -
For remote connections and connecting load distribution boxes, heavy duty terminal blocks have been provided. These terminal blocks are located on the rear of the unit. The neutral and ground are connected together at this panel. For use with an isolated neutral, remove the jumper strap between the neutral connection block and the ground lug. This will isolate the neutral from the ground and allow you a single point grounding at a distribution panel. When using these terminal blocks, be sure to use wire rated large enough to carry your full load or the full rated load of the generator.















CONTROL POWER

The ComAp controller consumes small amounts of battery power when it is in use. The controller comes with a power switch that disconnects battery power when it is not in use. The switch is designed with a safety relay that prevents it from removing power to the controller while the generator is operating. If the switch is turned off while the engine is running it will continue operating until the engine shuts down and then the controller will power down.

This switch should be used when the generator is not going to be used over the course of several days and the generator is not connected to a battery charger.

SHUTDOWN ALARMS

	Emergency Stop - The emergency stop was activated
	Overspeed - This is active if the speed is greater than 120% of nominal engine RPM
	Underspeed - Low engine RPM
	Low Oil Pressure - The engine will shut down when oil pressure drops below preset threshold
	High Coolant Temperature - The engine will shut down when the coolant temperature exceeds the preset threshold
	External Shutdown 1
	External Shutdown 2

	External Shutdown 3
	GCB Fail - Failure of generator circuit breaker
	Generator Overvoltage- The generator will shut down when voltage exceeds the present threshold
	Generator Undervoltage - The generator will shut down when output voltage drops below the preset threshold
	Generator Overfrequency - The generator frequency is out of limits
	Generator Underfrequency - The generator frequency is out of limits
	Generator Overload - The genset will shut down when output load exceeds the preset threshold
	Generator Short Circuit - The genset will shut down when output current exceeds the preset threshold
	Generator CCW Rotation - Incorrect generator phase sequence
	Start Fail - Genset start failed
	Stop Fail - Genset stop failed
	Battery Flat - If Protection will activate if the controller loses power during starting sequence due to bad battery condition. Controller will not try to start again
	Voltage Autodetect - If measured generator voltage doesn't correspond with predefined values for particular connection type when Autodetect value for B04 Connection Type is used
	Fuel Level Shutdown - Shutdown will occur if the fuel level is below shutdown threshold.

AVR WIRING

SR-7

The Mecc Alte SR-7/2G is an advanced, AVR regulator. Connections on the AVR have been factory set. Other than voltage adjustment, settings should never be changed.

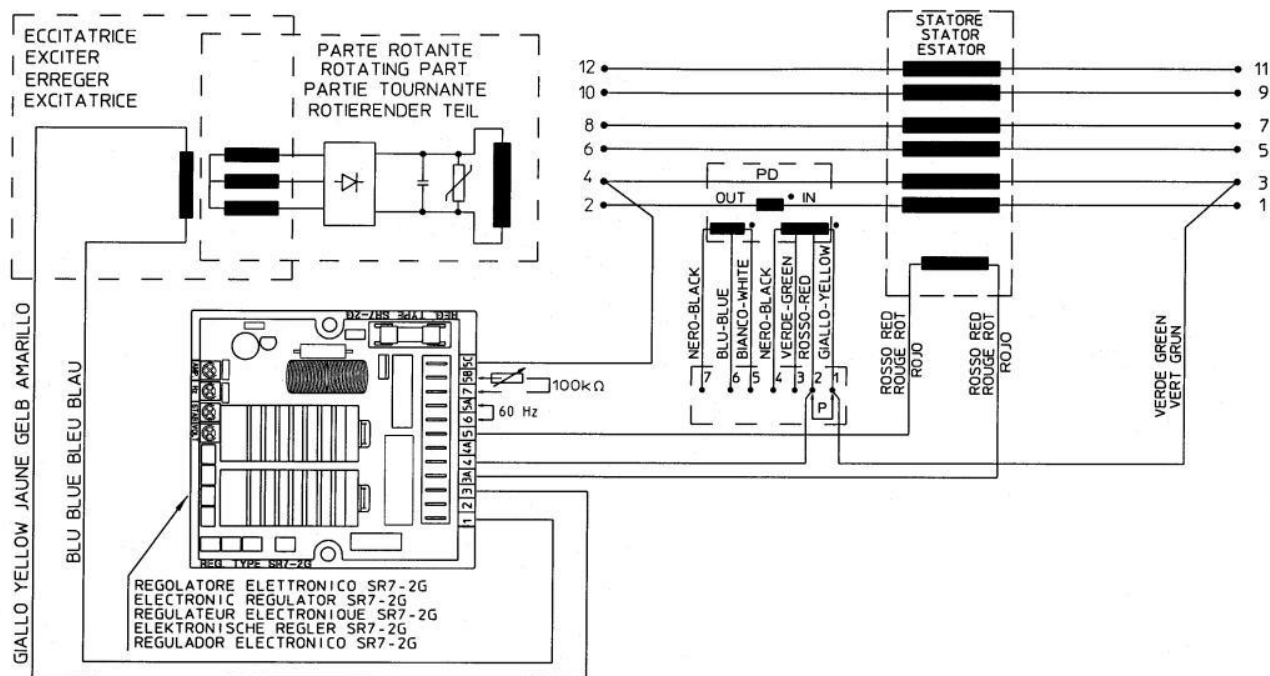

VOLT: Voltage. Rotate clockwise to increase voltage.
 STAB: Stability.
 HZ: Low Frequency.
 AMP: Overload.

MAINTENANCE

DANGER: PERSONAL INJURY/ EQUIPMENT DAMAGE

Place controller in manual mode, e-stop applied first. If an auto start signal comes on during maintenance, it may result in injury, death and equipment damage.

CHECKING THE OIL

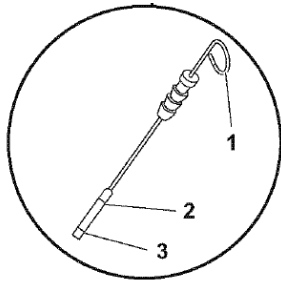

1. With engine in a level position, remove the dipstick (1) and wipe with a clean cloth.
2. Reinsert the dipstick.
3. Remove the dipstick and verify the oil level is between the upper (2) and lower (3) lines of the dipstick.
4. Reinsert dipstick. Fill oil if needed.

CHANGING THE OIL

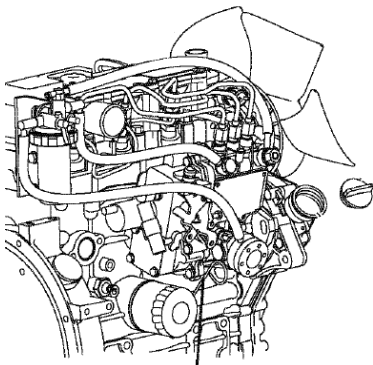

WINCO pipes the oil to drain to the outside for convenient maintenance.

Winco recommends our 5W-30 fully synthetic heavy duty engine oil to give you maximum cold weather protection while maintaining excellent performance in warmer weather. We have partnered with a national lubrication oil manufacturer to give you access to Winco private branded premium oil available at comparable prices to conventional oils. See your dealer for additional information.

CAUTION: PERSONAL INJURY

Only change oil when the engine is not running and is at a low temperature in order to avoid the risk of burns.

1. Place a drip pan or suitable container for catching the oil. WINCO has supplied a valve on the skid frame to hook a customer supplied 5/8" hose to conveniently run the oil to the drip pan.

Note: There are two drain valves, one for coolant and one for oil.

2. Drain the oil.
3. Once the oil has fully drained, close the valve.
4. Open the oil filler plug and top-off the filler pipe using lubricant oil with the recommended oil in the LUBRICATION section of this manual.
5. Use the dip stick to ensure the level of oil does not exceed the "MAX" limit.
6. Insert the dipstick and close the oil filler cap.
7. Dispose of oil in accordance to local codes. DO NOT dispose or allow oil to seep into the ground or sewer systems, doing so will cause environmental damage.

CHANGING OIL FILTER

The filter must be replaced when the lubricant oil is changed.

Only use filters with a filtering degree equal to the original filter.

CAUTION: PERSONAL INJURY

Only change oil when the engine is not running and is at a low temperature in order to avoid the risk of burns.

1. Disconnect the connector for the engine cable from the low oil pressure sensor.
2. Remove the low oil pressure sensor from the filter mount.
3. Use an oil filter wrench to unscrew and remove the oil filter.
4. Lightly coat the gasket on the new oil filter with engine oil.
5. Install the new engine oil filter manually by screwing on new oil filter canister until sealing ring abuts the filter head and tighten a further 3/4 turn. Do NOT use a strap wrench or similar tool to tighten the filter canister.
6. Warm up the engine by running it for 5 minutes and check for any oil leaks.
7. Recheck the oil level using the dipstick.
8. Add engine oil to engine oil filler port as needed until the level is between the maximum and minimum lines shown on the dipstick.

CHANGE FUEL FILTER

WARNING

Do not fill up the new filter before it is fitted to the support, to avoid inserting harmful impurities into the injection system and circuit.

CAUTION: PERSONAL INJURY

Only change fuel filter when the engine is not running and is at a low temperature in order to avoid the risk of burns.

1. Remove the filter by unscrewing it. Keep gasket.
2. Damp the gasket with engine oil.
3. Hand screw the new filter into place until the seal gasket touches the support, then lock by a further 3/4 of a turn.

After replacing the fuel filter, there may be oil bubbles in the fuel circuit. Bleed the residual air from the filter by loosening the breather screw and connecting it to a suitable container with a transparent flexible pipe. Start the manual fuel pre-filter pump until the fuel leaving the breather screw is completely free of air bubbles. Tighten the breather screw and start the engine. Let the engine run idle for a few minutes to remove any residual air.

FILLING COOLANT

CAUTION: PERSONAL INJURY

Only fill coolant when the engine is not running and is at a low temperature in order to avoid the risk of burns.

CAUTION: EQUIPMENT DAMAGE

Never use a cold coolant mixture to top up the radiator of a hot engine if the coolant level is very low; this could cause serious engine damage.

1. Ensure the radiator drain valve and the plug on the engine block are secure.
2. Open the valve and slowly pour the coolant into the radiator until it is even with the lip of the filler port.
3. Reinstall radiator cap.

CHANGING COOLANT

WINCO pipes the coolant to drain to the outside for convenient maintenance.

Engine coolant contaminated with rust or water scale reduces the cooling effect. Even when extended life engine coolant is properly mixed, the engine coolant gets contaminated as its ingredients deteriorate. Drain, flush and refill the cooling system with new coolant every 1000 hours or every 1 year, whichever comes first.

CAUTION: PERSONAL INJURY

Only proceed when the engine is not running and is at a low temperature in order to avoid the risk of burns.

1. Loosen the seal elements, remove the sleeves connecting the engine circuit to the heat exchanger and wait until it has emptied completely. When empty, repair the circuit making sure that the sleeves are perfectly sealed
2. Refill the engine and the heat exchanger until complete top-off.
3. With the filler cap open, start the engine and keep it idling for nearly one minute. This phase facilitates the cooling liquid air bleed.
4. Stop the engine and top up again.
5. Dispose of coolant in accordance to local codes. DO NOT dispose or allow oil to seep into the ground or sewer systems, doing so will cause environmental damage.

CLEANING RADIATOR

The surfaces of the radiator come into contact with the outside air and can be subject to deposits and impurities. Clean in accordance to the maintenance schedule with compressed air or steam.

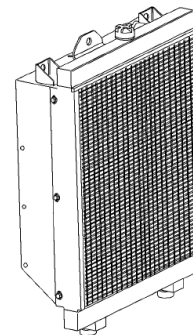

1. Check that the radiator air inlets are free from dirt (dust, mud, straw, etc.).
2. Clean them if necessary, using compressed air or steam.

CHANGING AIR FILTER

The engine performance is adversely affected when the air cleaner element is clogged with dust.

WARNING: EQUIPMENT DAMAGE

Never operate the engine with the air cleaner element removed. This may allow foreign material to enter the engine and damage it. Do NOT remove filter while engine is running.

WARNING: EQUIPMENT DAMAGE

Take care to ensure that the parts are reassembled correctly. Imperfect assembly might result in unfiltered air being sucked into the engine, causing serious damage.

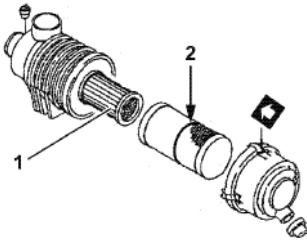

1. Remove the filter cover by unlatching it.
2. Remove the external cartridge, after unfastening the second locking handle; during this operation, take care to ensure that no dust gets into the sleeve.
3. Check that there is no dirt. If there is, clean the filter element. Blow dry compressed air through the filter element, from the inside outward (maximum pressure 200 kPa). Do not use detergents; do not use diesel.
4. Replace the filter if any breakages or tears are found.
5. Reassemble by repeating the above operations in reverse order
6. Reinstall the element into the air cleaner case.

STORAGE

PREPARING THE ENGINE FOR A LONG PERIOD OF INACTIVITY

ANGER

Never short out the battery terminals, including when checking the remaining battery charge. This will result in a spark and may cause an explosion or fire. Use a hydrometer to check the remaining battery charge.

If the electrolyte is frozen, slowly warm the battery before you recharge it.

ARNING

Batteries contain sulfuric acid. Never allow battery fluid to come in contact with clothing, skin or eyes. Always wear safety goggles and protective clothing when servicing batteries to avoid severe burns. If battery fluid comes in contact with the eyes and/skin, immediately flush the area with a large amount of clean water and seek prompt medical treatment.

AUTION

Always wear eye protection when servicing the engine and when using compressed air or high-pressure water. Dust, flying debris, compressed air, pressurized water or steam may injure your eyes.

In the case of a planned period of inactivity that lasts longer than one month, to prevent the interior parts of the engine and some components of the injection system from oxidizing, prepare the engine as follows:

Store indoors in dry area.

Perform the next preventative maintenance procedure. For example, if there are 10 hours remaining before the 250 hour maintenance, you should perform the maintenance prior to storing the generator set. See Maintenance Schedule on page 23 of this manual.

In order to prevent oxidation of the internal parts of the engine and of certain components in the injection system, when the engine is expected to be inoperative for periods of more than two months, the following operations must be carried out in preparation for this:

1. Clean the exterior of the engine so it is free of grease and oil.
2. Fill the engine with protective oil type 30/M (or alternatively oil that complies with MIL 2160B type 2 specifications), up to the "minimum" level indicated on the dipstick. Start the engine and keep it running for approximately 5 minutes. Drain afterwards
3. Attach signs reading "ENGINE WITHOUT OIL" to the engine and to the on-board control panel.
4. Drain the fuel from the injection circuit, from the filter and from the injection pump pipes.
5. Lubricate exposed parts of the engine speed control system.
6. Protect the air cleaner, muffler, and electrical components from water and dust.
7. Disconnect the negative (-) battery cable to prevent the battery from discharging.
8. Charge battery once a month during storage.
9. Drain the coolant, if it has not been mixed with suitable antifreeze and corrosion inhibitors, and affix a sign to indicate the fact. In the event of prolonged inactivity, the operations described must be repeated every 6 months, following the procedure given below:
 - A) drain the 30/M protective oil from the sump;
 - B) repeat the operations described from point 2 to point 7.

Should you intend to protect external parts of the engine, proceed by spraying OVER 19 AR protective liquid on unpainted metal parts, such as the flywheel, pulleys and the like, avoiding belts, connector cables and electrical equipment.

MAINTENANCE SCHEDULE

The ultimate aim of a preventive maintenance program is to maintain the equipment in optimum condition, for the maximum amount of time during its useful life. The detection of faults before they develop into major problems will decrease downtime. A regular schedule of cleaning and inspection will help assure trouble-free operation. Personnel responsible for maintenance should set up a schedule for inspection, and cleaning at intervals calculated to keep the equipment in good condition. In making up a schedule, keep the following in mind:

- A. New equipment must be carefully monitored until extended operation has demonstrated that it is performing satisfactorily.
- B. Old equipment requires more frequent inspection (and possibly servicing) than similar equipment that has lower hours.
- C. Time spent in cleaning, inspecting and correcting minor defects before they become major troubles saves time in overhaul and repair.

DAILY
Check Engine Oil Level
Check Coolant Level and for Leakage
Check Air Filter
Check/drain fuel filter/water separator
EVERY 50 HOURS
Check and adjust cooling fan V-belt (1st time then every 250 hours after)
Replace engine oil filter (1st time then every 250 hours after)
EVERY 250 HOURS
Replace fuel filter
Check and clean radiator fins
Check Exhaust System for Damage
Check Battery
Drain Fuel Tank
EVERY 500 HOURS
Change air filter
EVERY 1000 HOURS
Drain, flush and refill cooling system with fresh coolant
Adjust intake/exhaust valve clearance
EVERY 1500 HOURS
Inspect crankcase breather system
EVERY 3000 HOURS
Inspect, clean, and test EGR valve

The frequency is a function of the environmental conditions and product wear/efficiency. After long periods of inactivity of the engine, carry out the checks before starting the engine. If the warning signal is given indicating that the filter is clogged, the filter must be replaced.

After performing all maintenance operations that require disconnection of the batteries, make sure the clamps have been securely reconnected on the poles.

TROUBLESHOOTING TABLE

NOTE: Before doing any trouble shooting, check the digital display on the ComAp IntelliNano. Normally, it will tell why the unit has failed. This will shorten your trouble shooting time and in many cases, prevent the replacement of parts that may not be defective.

Problem	Possible Causes
Unit will not crank when power fails	Digital genset not in AUTO Transfer control switch not in AUTOMATIC position Incorrect wiring between ATS and genset Defective control relay in ATS Fuse(s) blown in the ComAp IntelliNano Defective ComAp IntelliNano Loose or dirty battery terminals Defective starter Defective start solenoid Low/dead battery
Engine won't crank	Low/dead battery Blown DC fuses Defective ComAp IntelliNano Defective key switch Loose or dirty battery terminals Defective starter Defective start solenoid Locked up engine genset Defective engine harness Improper battery voltage to start solenoid, fuel pump, or fuel solenoid
Engine cranks but will not start	Improper fuel delivery to the unit Fuel supply shut off Fuel tank empty Air in the fuel system Engine fuel solenoid has not opened Defective fuel pump Defective fuel solenoid Defective engine harness Improper battery voltage to fuel pump or fuel solenoid
Engine starts, then stops and alarm light comes on	Engine oil pressure is low Engine has high water temperature Engine has overspeed Engine has gone into overcrank No output from AC generator Loss of speed signal Loss of run signal
Engine will not come up to speed after it starts	Insufficient fuel volume getting to the unit <ol style="list-style-type: none"> 1. Too small of fuel line 2. Fuel racks not open properly Governor is defective AC short in generator components
ATS will not transfer to Emergency Supply (generator)	No AC generator output Defective ATS control board. See ATS manual Circuit breaker open or defective
ATS will not re-transfer to normal power	Proper power line not available at line terminals in ATS panel Defective ATS control board. See ATS manual
No AC output from generator	Defective diode Defective voltage regulator Defective rotor Defective stator Defective exciter rotor Defective exciter stator AC short in the output leads Defective/open generator output breaker Wiring error

WIRING SIZE TABLE

The table below is based on Table 310.16 in the National Electric Code 2020 edition. Allowable ampacities of insulated conductors rated 0 through 2000V, 75°C through 90°C. Not more than three current-carrying conductors in Raceway, Cable, or Earth (direct buried). Adjust for 40°C (104°F) ambient temperature.

SIZE AWG OR KCMIL	75°C (167°F)	90°C (194°F)	75°C (167°F)	90°C (194°F)
	Wire Type: RHW, THHW, THW, THWN, XHHW, XHWN, USE, ZW	Wire Type: TBS, SA, SIS, FEP, FEPB, MI, PFA, RHH, RHW-2, THHN, THHW, THW-2, THWN-2, USE-2, XHH, XHHW, XHHW-2, XHWN, XHWN-2, XHHN, Z, ZW-2	Wire Type: RHW, THHW, THW, THWN, XHHW, USE	Wire Type: TBS, SA, SIS, THHN, THW-2, THWN-2, RHH, RHW- 2, USE-2, XHH, XHHW, XHHW- 2, ZW-2
	COPPER		ALUMINUM OR COPPER-CLAD ALUMINUM	
8	50	55	40	45
6	65	75	50	55
4	85	95	65	75
3	100	115	75	85
2	115	130	90	100
1	130	145	100	115
1/0	150	170	120	135
2/0	175	195	135	150
3/0	200	225	155	175
4/0	230	260	180	205
250	255	290	205	230
300	285	320	230	260
350	310	350	250	280
400	335	380	270	305
500	380	430	310	350
600	420	475	340	385
700	460	520	375	425
750	475	535	385	435
800	490	555	395	445
900	520	585	425	480
1000	545	615	445	500
1250	590	665	485	545
1500	625	705	520	585
1750	650	735	545	615
2000	665	750	560	630

For additional information, see table 310.16 of the National Electric Code.

RECEPTACLE WIRING DIAGRAM

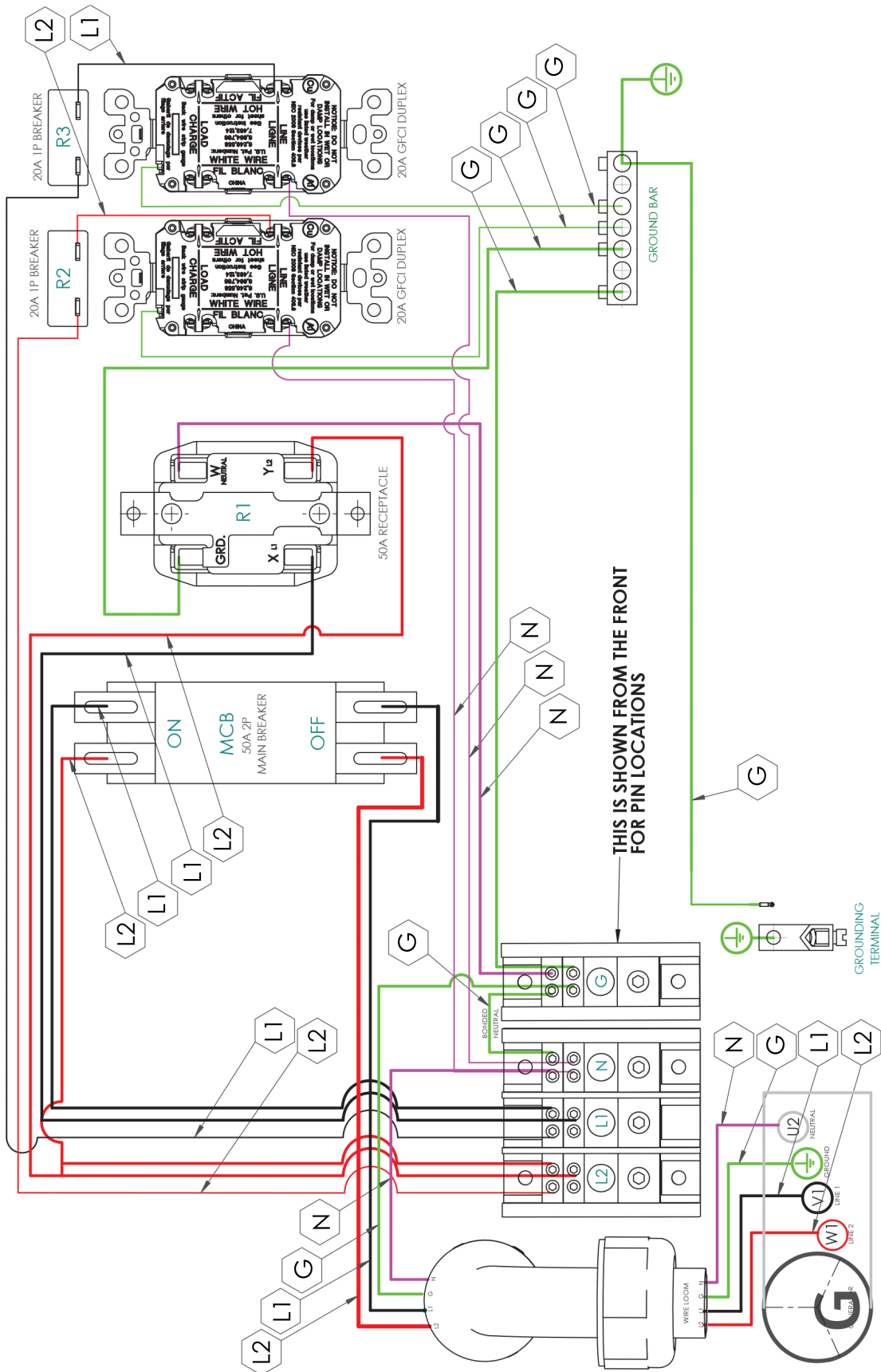

CONTROLLER WIRING DIAGRAM

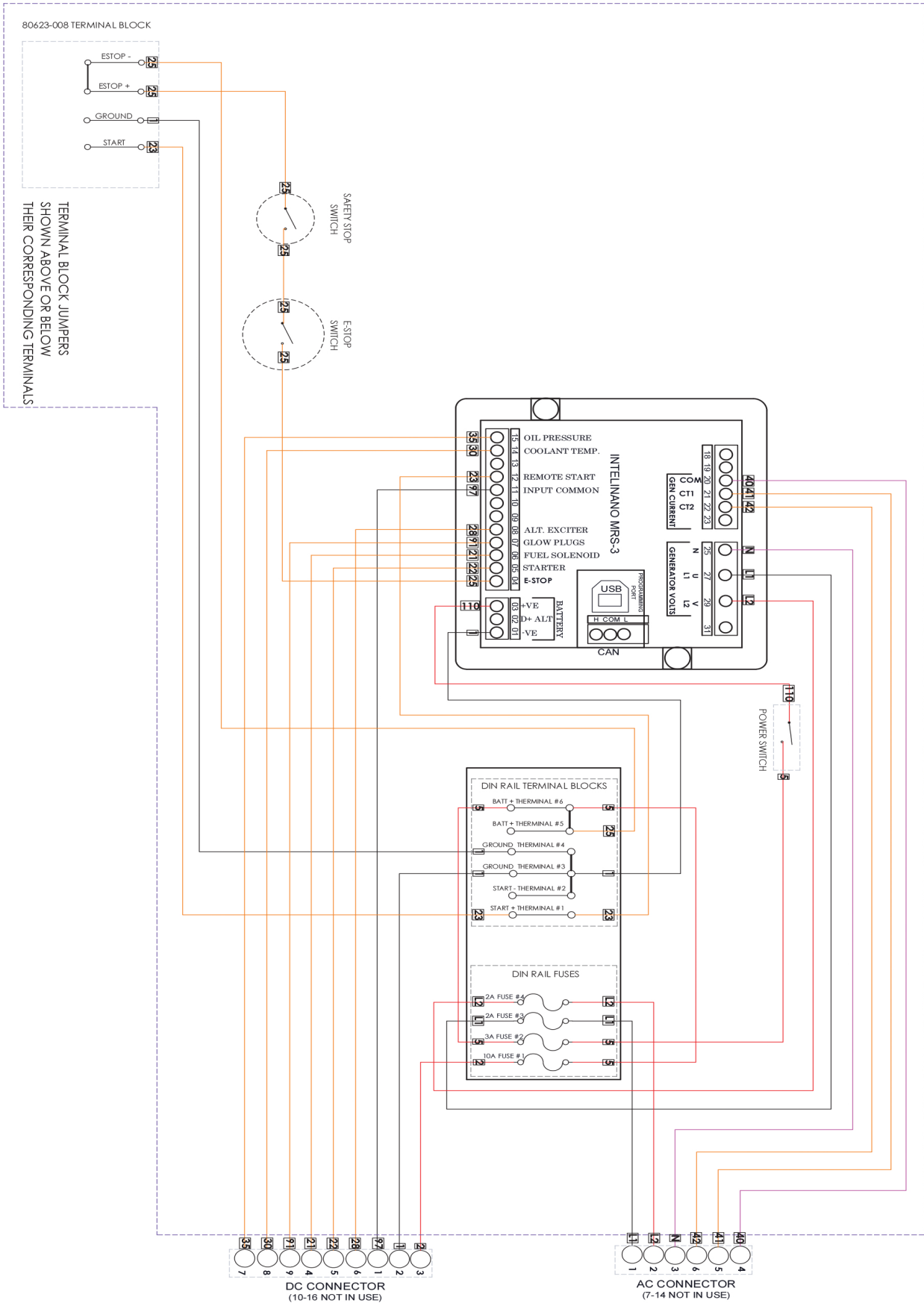

WIRING DIAGRAMS

SINGLE PHASE ZIG ZAG

(12 Lead)

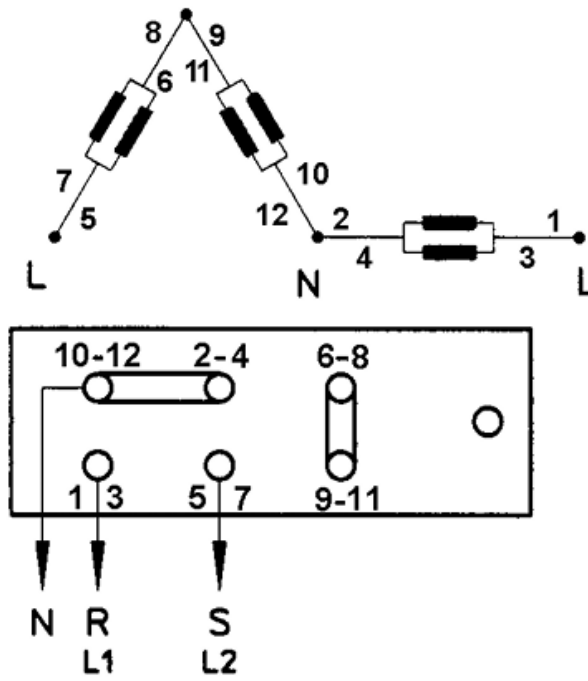

ENGINE HARNESS

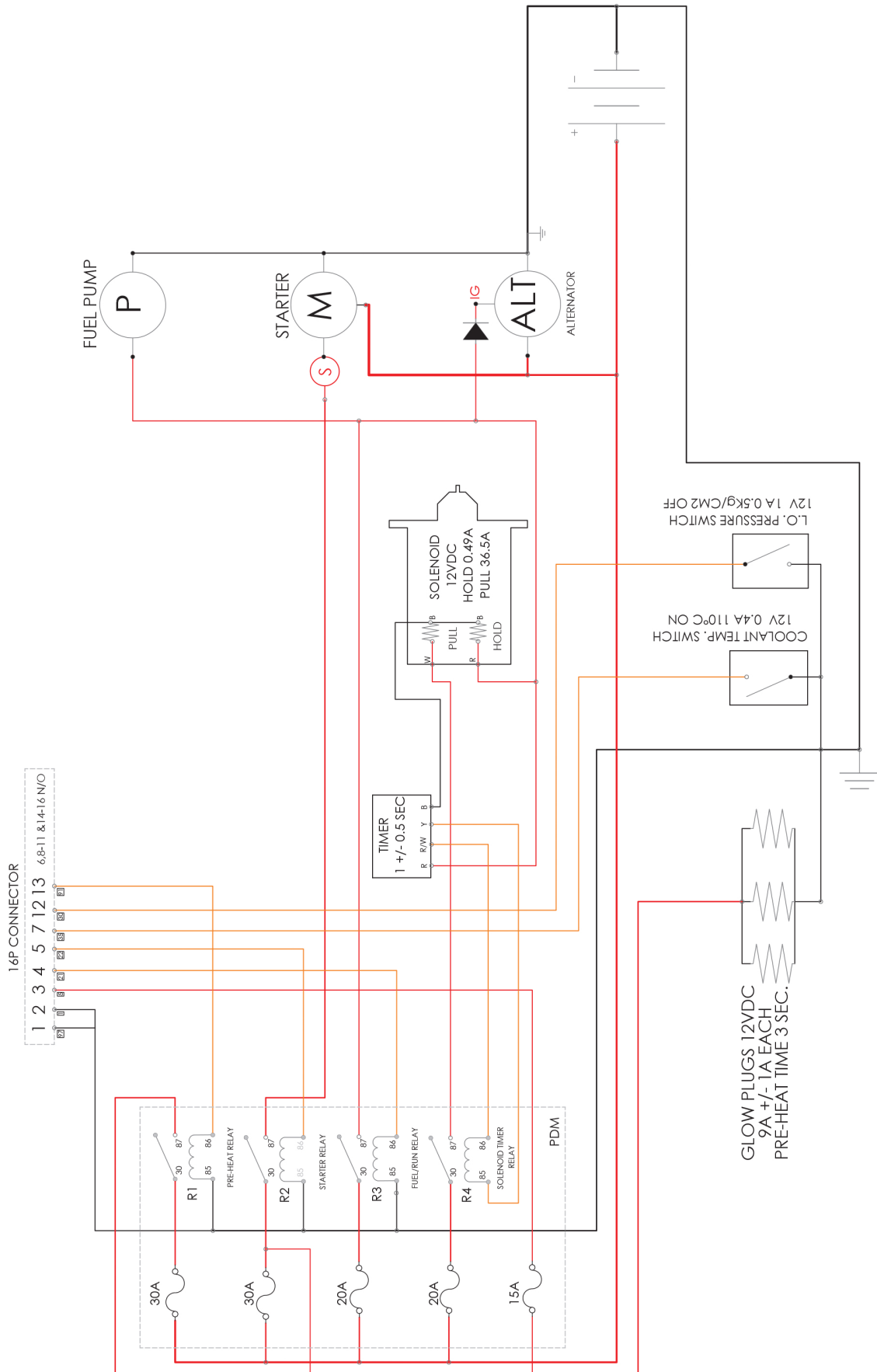

LIMITED WARRANTY

WINCO Incorporated warrants to the original purchaser for the warranty period that goods manufactured or supplied by it will be free from defects in workmanship and material, provided such goods are installed operated and maintained in accordance with WINCO written instructions.

WINCO's sole liability, and Purchaser's sole remedy for a failure under this warranty, shall be limited to the repair of the product. At WINCO's option, material found to be defective in material or workmanship under normal use and service will be repaired or replaced. For warranty service, contact a Winco Authorized Service Center within the warranty period from date of purchase.

*NOTE: Units that are resold by original owner are not covered under this warranty. Any further warranty, whether expressed or implied, rests solely with the reseller.

THERE IS NO OTHER EXPRESS WARRANTY.

To the extent permitted by law, any and all warranties, including those of merchantability and fitness for a particular purpose, are limited to the warranty period from date of purchase. In no event is WINCO liable for incidental or consequential damages.

Note: Some states do not allow limitation on the duration of implied warranty and some states do not allow the exclusion or limitation of incidental or consequential damages, so the above limitations may not apply in every instance. This warranty gives you specific legal rights which may vary from state to state.

WINCO, INC. WARRANTY EFFECTIVE DATE

Air cooled units purchased for stock have 1 year to be sold. The warranty to the original retail customer commences on the date of sale of the product to them. All liquid cooled units have 180 days from the Winco invoice to submit a start up date. If no startup form is submitted, then warranty period starts on the Winco invoice date unit was sold.

Date of sale is defined as the day the customer takes delivery of the product. This warranty shall remain in effect to the original purchaser for the period stated on the sales literature. The warranty is not transferable and the retail customer must retain his original bill of sale as proof of purchase date.

WINCO, Inc. agrees to the following obligations during the warranty period:

1. To warrant any defect in material or workmanship of products sold under the WINCO and DYNA brand names in accordance with the warranty statements in the operator's manuals.
2. To reimburse authorized WINCO, Inc. Service Centers/Dealers for the cost of parts plus standard ground UPS shipping charges for all valid warranty repairs and to reimburse same said service centers/dealers for reasonable labor charges based on WINCO's current warranty labor reimbursement rate.
3. To furnish its authorized service centers/dealers with the necessary parts to make the repairs. WINCO Generator Warranty Periods & Restrictions

WINCO GENERATOR WARRANTY PERIODS & RESTRICTIONS

Industrial Portables

WL Models - 3 Years, See Notes 1 & 2

W Models - 3 Years, See Notes 1, 2, & 5

DP Models - 3 Years, See Notes 1 & 2

HPS Models - 2 Years, Home Use ONLY; Commercial use* is 90 Day Warranty, See Note 1

EMERGEN-C (EC) Series

2 Years, See Note 1

DE Series

1 Year/2000 hours, No Travel Time

Mobile Diesel Series

1 Year/2000 hours, No Travel Time

PTO Series

15kW & 10kW - 1 Year, Limited Farm Standby Only

25kW thru 165kW - 3 Years, Limited Farm Standby Only/Commercial use* 1 Year

Two Bearing Series

1 Year, Bench Labor and Parts only

Gaseous/Packaged Standby Series (PSS)

Air-Cooled Models (PSS8, PSS12, & PSS20) – 2 Years/2000 Hours Standby Only See Notes 3 & 4 Prime Power use 1 Year/2000 Hours See Notes 3 & 4

Liquid-Cooled Models (PSS21 - PSS150) - 2 Years/2000 Hours Standby Only See Notes 3 & 4 Prime Power use 1 Year/2000 Hours See Notes 3 & 4

Diesel Standby Series (DR)

Liquid-Cooled Models (DR12 - DR600) - 2 Years/2000 Hours Standby Only See Notes 3 & 4

Prime Power use 1 Year/2000 Hours See Notes 3 & 4

Accessories (Installed on Generator or shipped loose)

1 Year from factory invoice or 2000 Hours (whichever occurs first)

Automatic Transfer Switches (ATS)

See ATS Manufacturer's Warranty

NOTES

Note 1: First 2 years of warranty coverage includes Parts and Bench Labor Only, no travel time or labor allowance for removal or reinstallation of the product from its application.

Note 2: 3rd Year warranty coverage is parts only/no labor.

Note 3: Round trip mileage is limited to 200 miles per trip and a total of 2 trips per repair unless authorized in writing by the WINCO Service Dept.

Note 4: Mileage allow on permanently installed units only. Trailer mount units is bench labor only.

Note 5: W3000 is a 1 Year Warranty.

*Commercial use is defined as Construction, Rental, Prime Power, or use in a business of any type including agricultural and hobby. Prime Power use is defined as any application where the generator set is being used 'off-grid' where there is no utility power present. Standby use is defined as an application where utility power is present and- the generator set is used as emergency backup during utility power outages.

WINCO reserves the right to change or improve its products without incurring any obligations to make such changes or improvements on products purchased previously.

EXCLUSIONS:

WINCO does not warrant Engines. Engines are covered exclusively by the warranties of their respective manufacturers.

WINCO does not warrant Batteries, or Other Component Parts that are warranted by their respective manufacturers.

WINCO does not warrant modifications or alterations which were not made by WINCO, Inc.

WINCO does not warrant products which have been subjected to misuse and/or negligence or have been involved in an accident.

This warranty does not include travel time, mileage, or labor for removal or reinstallation of WINCO product from its application, unless specifically authorized.

WHAT IS COVERED BY WARRANTY

1. Generator end including rotor, stator, end brackets, and bearing.
2. Control box including transformers, circuit breakers, wiring, resistors, and switches.
3. LP/NG fuel system including fuel solenoid, demand regulator, carburetor, and hoses.
4. Cradle assembly including cradle, cross member, and shock mounts that fail. Shock mounts damaged from rough handling are not covered.
5. Reasonable travel time for the PSS & DR series generators only, that are permanently installed.
6. Ground shipping charges for warranty parts, no premium service, domestic US shipments only.

WHAT IS NOT COVERED BY WARRANTY

1. Products which have been subjected to alteration, modification, neglect or unauthorized repairs not approved in writing by Winco, Inc.
2. Products no longer owned by the original purchaser.
3. Products with shipping or freight damage. File a freight claim with the delivery carrier.
4. Products suffering normal wear, accidents, improper maintenance or improper protection in storage. Products damaged by rough handling, such as shock mounts on cradle assemblies.
5. Pressure or steam cleaning of products, cleaning of fuel system, or flushing of cooling system.
6. Replacement of filter, belts, antifreeze, or lubricants.
7. Electrical items, such as light bulbs, receptacles, spark plugs, or any items damaged by welding or jump starting.
8. Any repeat or shop come-back repairs resulting from poor service work or improper diagnosis and testing. Replacement of parts as a trial-and-error method of diagnosis will not be considered for warranty.
9. Replacement parts other than those sold by Winco, Inc.
10. Damage caused by fire, flood, lightning or any other natural disaster.
11. Damage caused by improper protection during installation, (i.e. not protecting contactor in the ATS panel and getting wire trimming or debris from drilling the box in the contactor coil or contacts.)
12. Damage caused by over loading of the generator and failure to adequately provide overload protection.
13. LP/NG fuel adjustments or conversion from one fuel to another.
14. Adjustment of any kind, all units are 100% load tested before shipping.
15. Any damage caused by the use of the equipment for purposes other than for which it was designed.
16. Engines - All engines used by Winco, Inc. are warranted by their respective manufacturer's.
17. Batteries - Must be returned to original battery manufacturer.
18. Damage caused by improper installation or failure to provide adequate ventilation.
19. Cosmetic repairs, such as repainting.
20. Freight charges for transportation to and from a Warranty Service Center.
21. Rental costs of renting replacement generators.
22. Travel time or service calls unless specifically authorized by Winco, Inc. in writing.

GENERAL INFORMATION

The WINCO, Inc. Service Department is open from 7:30 AM to 4:30 PM Central Standard time.

It is located at 225 South Cordova Ave., Le Center, MN, 56057-1805.

Phone Numbers: Service Department - 507-357-6831 FAX Line - 507-357-4857. Email address is service@wincogen.com

The phone number to for the General Switchboard/Sales Department is 507-357-6821.

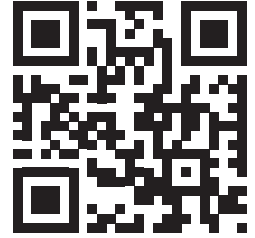

WINCO[®]
GENERATORS



AN AMERICAN COMPANY

225 S. CORDOVA AVE • LE CENTER, MN 56057
Sales: 507-357-6821 • sales@wincogen.com
Service: 507-357-6831 • service@wincogen.com
www.wincogen.com

